

67483

PCB Piezotronics Inc. claims proprietary rights in the information disclosed hereon. Neither it nor any reproduction thereof will be disclosed to others without the written consent of PCB Piezotronics Inc.

REVISIONS		
REV	DESCRIPTION	DIN
NR	RELEASED TO DRAFTING	47581

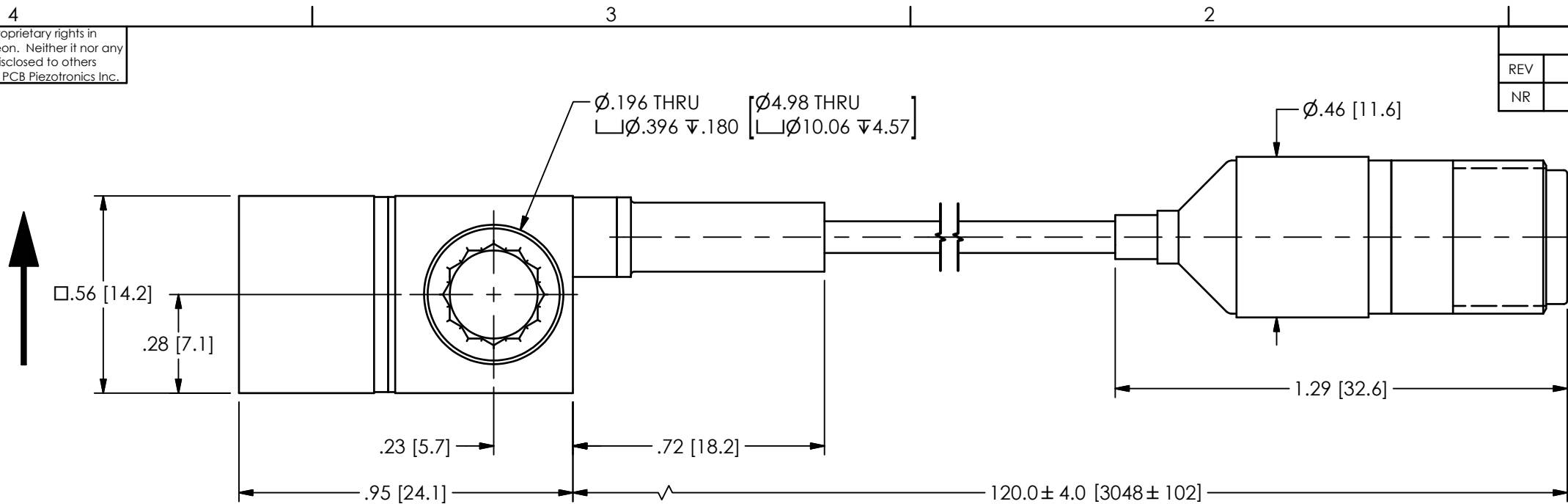

DIRECTION OF ACCELERATION TO PROVIDE A POSITIVE OUTPUT SIGNAL

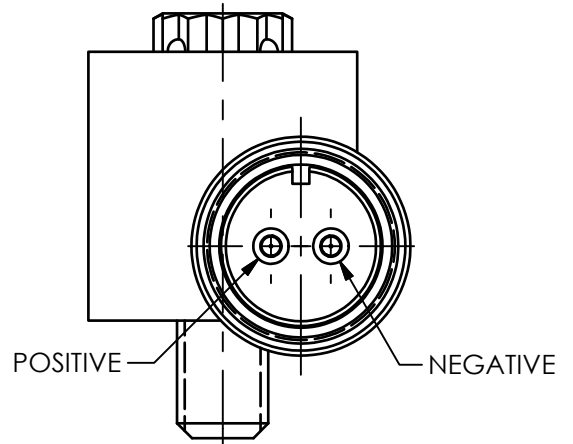
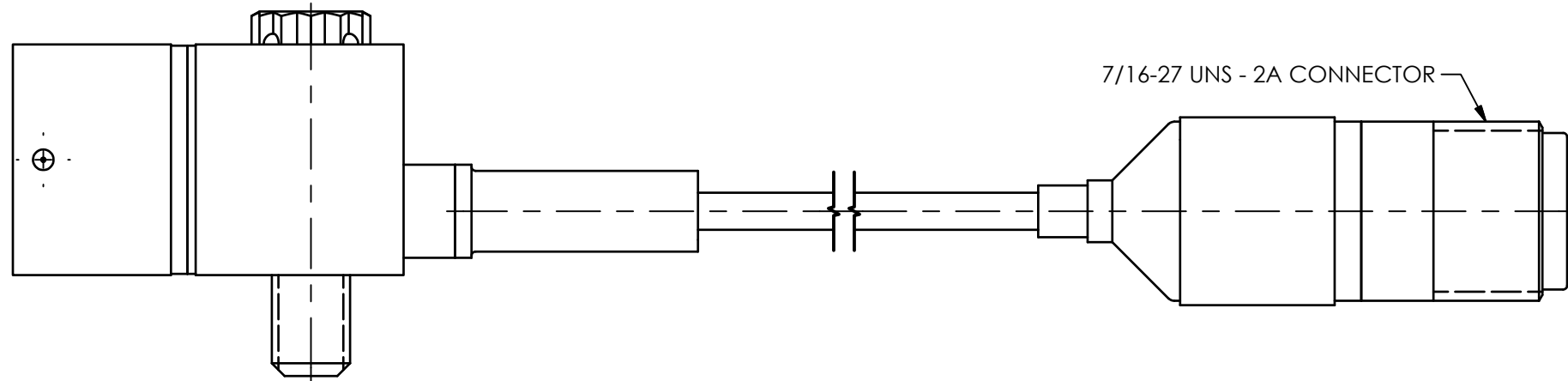

MOUNTING HOLE PREPARATION:
 1) Ø.159 [Ø4.04] ±(X) +.130 [3.30]
 10-32 UNJF-3B ±(X) +.035 [.89]
 WHERE: (X)=DISTANCE MOUNTING SCREW EXTENDS PAST MOUNTING SURFACE [I.E. SCREW INSERTION DEPTH]

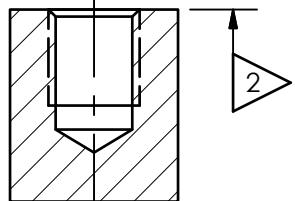

- 5.) CABLE MINIMUM BEND RADIUS: .25 [6.35]
- 4.) RECOMMENDED MOUNTING TORQUE: 10-20 INCH POUNDS [113-225 NEWTON CENTIMETERS]
- 3.) FOR BEST RESULTS, PLACE A THIN LAYER OF SILICONE GREASE (OR EQUIVALENT) ON INTERFACE PRIOR TO MOUNTING
- 2) MOUNTING SURFACES SHOULD BE FLAT TO WITHIN .001 [.03] TIR ACROSS A 2" DIAMETER AREA WITH A SURFACE FINISH OF 63 [1.61] OR BETTER FOR BEST RESULTS
- 1) DRILL PERPENDICULAR TO MOUNTING SURFACE TO WITHIN ± 1°

UNLESS OTHERWISE SPECIFIED TOLERANCES ARE:		DRAWN		CHECKED		ENGINEER	
DIMENSIONS IN INCHES	DIMENSIONS IN MILLIMETERS [IN BRACKETS]	KRM	1/31/18	KRM	1/31/18	JJD	1/31/18
DECIMALS XX ±.01 XXX ±.005	DECIMALS X ±.03 XX ±.013	TITLE INSTALLATION DRAWING MODEL 357A95 ACCELEROMETER					
ANGLES ± 2 DEGREES	ANGLES ± 2 DEGREES						
FILLETS AND RADII .003 - .005	FILLETS AND RADII 0.07 - 0.13	CODE IDENT. NO. 52681		DWG. NO. 67483		3425 WALDEN AVE. DEPEW, NY 14043 (716) 684-0001 E-MAIL: sales@pcb.com	
		SCALE: 2.5X		SHEET 1 OF 1			

PCB PIEZOTRONICS™

3425 WALDEN AVE. DEPEW, NY 14043
(716) 684-0001 E-MAIL: sales@pcb.com

CODE IDENT. NO. 52681
DWG. NO. 67483

SCALE: 2.5X SHEET 1 OF 1