

PCB Piezotronics Inc. claims proprietary rights in the information disclosed hereon. Neither it nor any reproduction thereof will be disclosed to others without the written consent of PCB Piezotronics Inc.

59472

REVISIONS		
REV	DESCRIPTION	DIN
NR	RELEASED TO DRAFTING	46135

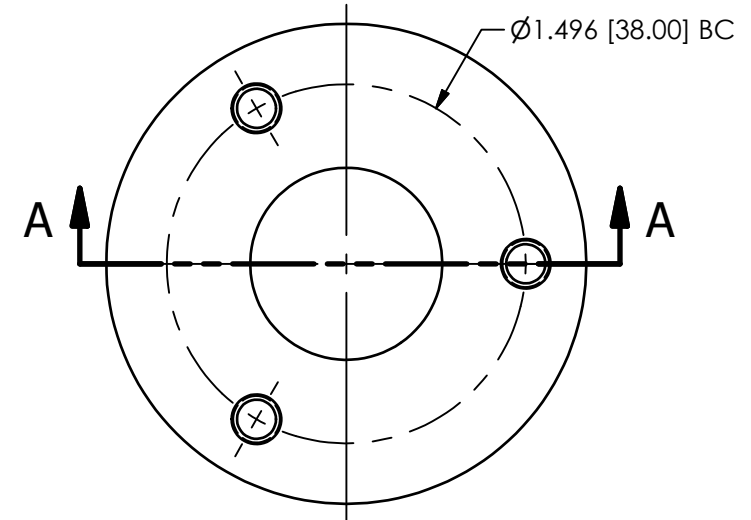
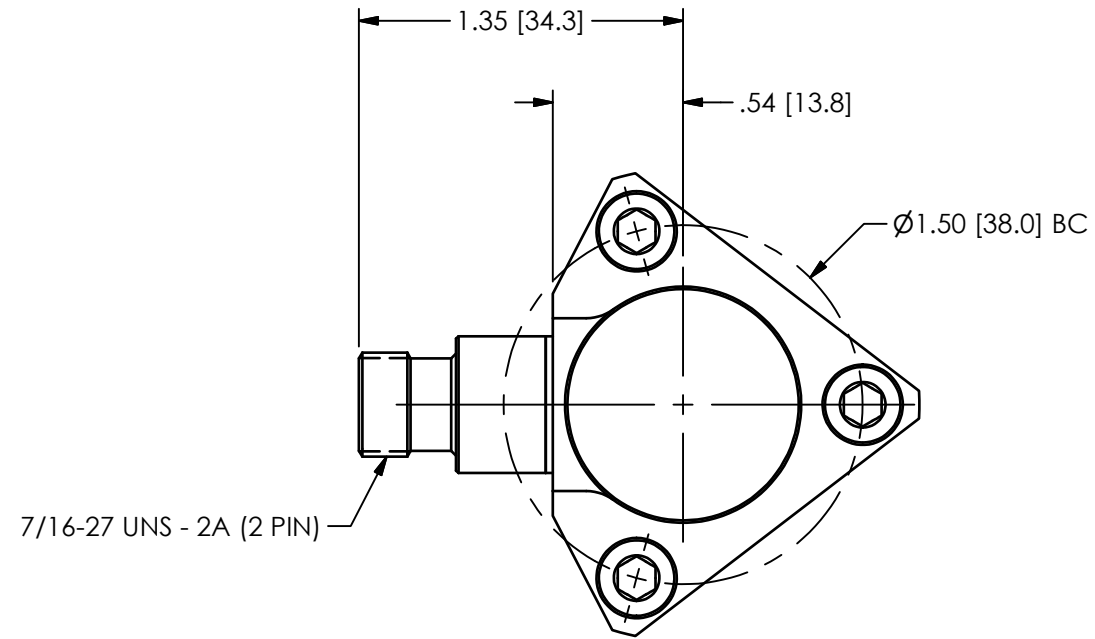

MOUNTING DETAIL

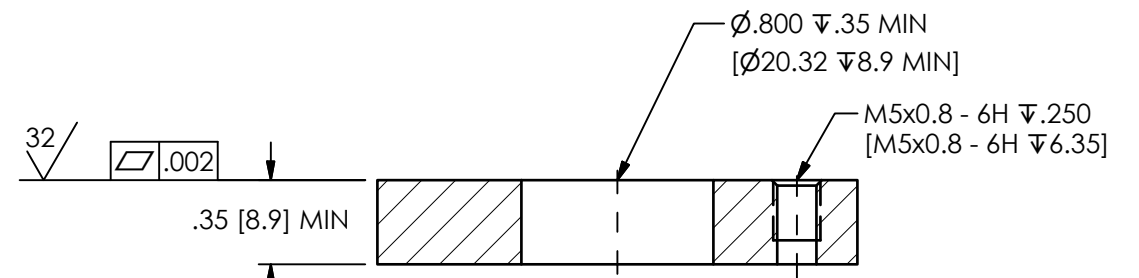
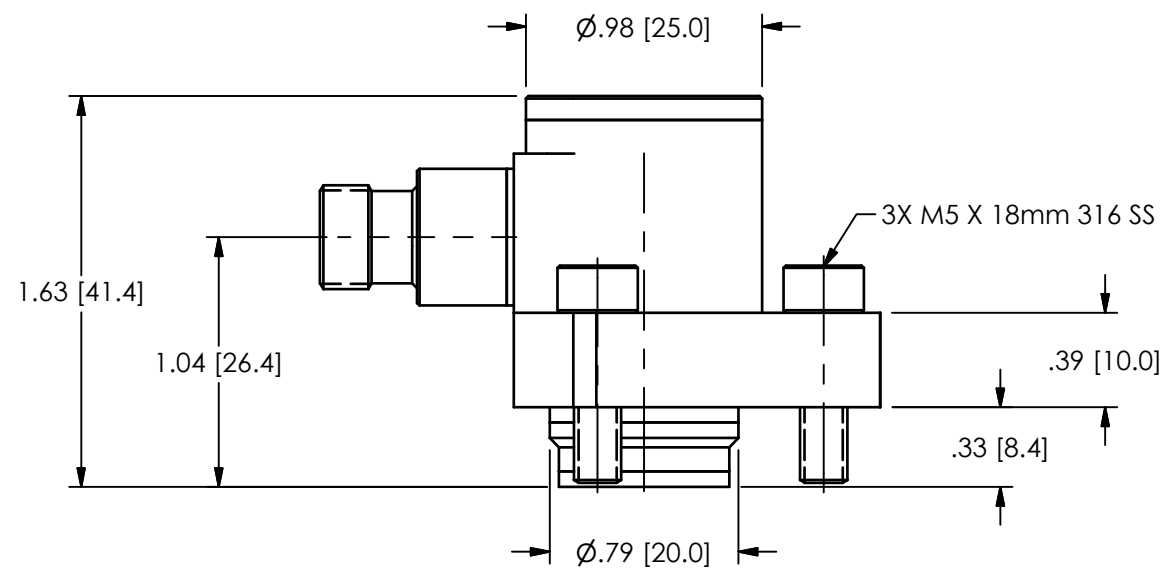

SECTION A-A

1.) RECOMMENDED MOUNTING TORQUE: 3.4 ft-lb [10Nm]

UNLESS OTHERWISE SPECIFIED TOLERANCES ARE:		DRAWN		CHECKED		ENGINEER	
DIMENSIONS IN INCHES	DIMENSIONS IN MILLIMETERS [IN BRACKETS]	KRM	2/20/17	ECB	2/20/17	AJA	2/20/17
DECIMALS XX $\pm .01$ XXX $\pm .005$	DECIMALS X ± 0.3 XX ± 0.13	TITLE INSTALLATION DRAWING PRESSURE TRANSDUCER MODEL 176A04					
ANGLES ± 2 DEGREES	ANGLES ± 2 DEGREES						
FILLETS AND RADII .003 - .005	FILLETS AND RADII 0.07 - 0.13	CODE IDENT. NO. 52681		DWG. NO. 59472		SCALE: 1.25X SHEET 1 OF 1	

PCB PIEZOTRONICS™

3425 WALDEN AVE. DEPEW, NY 14043
(716) 684-0001 E-MAIL: sales@pcb.com