

PCB Piezotronics Inc. claims proprietary rights in the information disclosed hereon. Neither it nor any reproduction thereof will be disclosed to others without the written consent of PCB Piezotronics Inc.

40623

REVISIONS		
REV	DESCRIPTION	DIN
A	UPDATED OVERALL LENGTH	53183

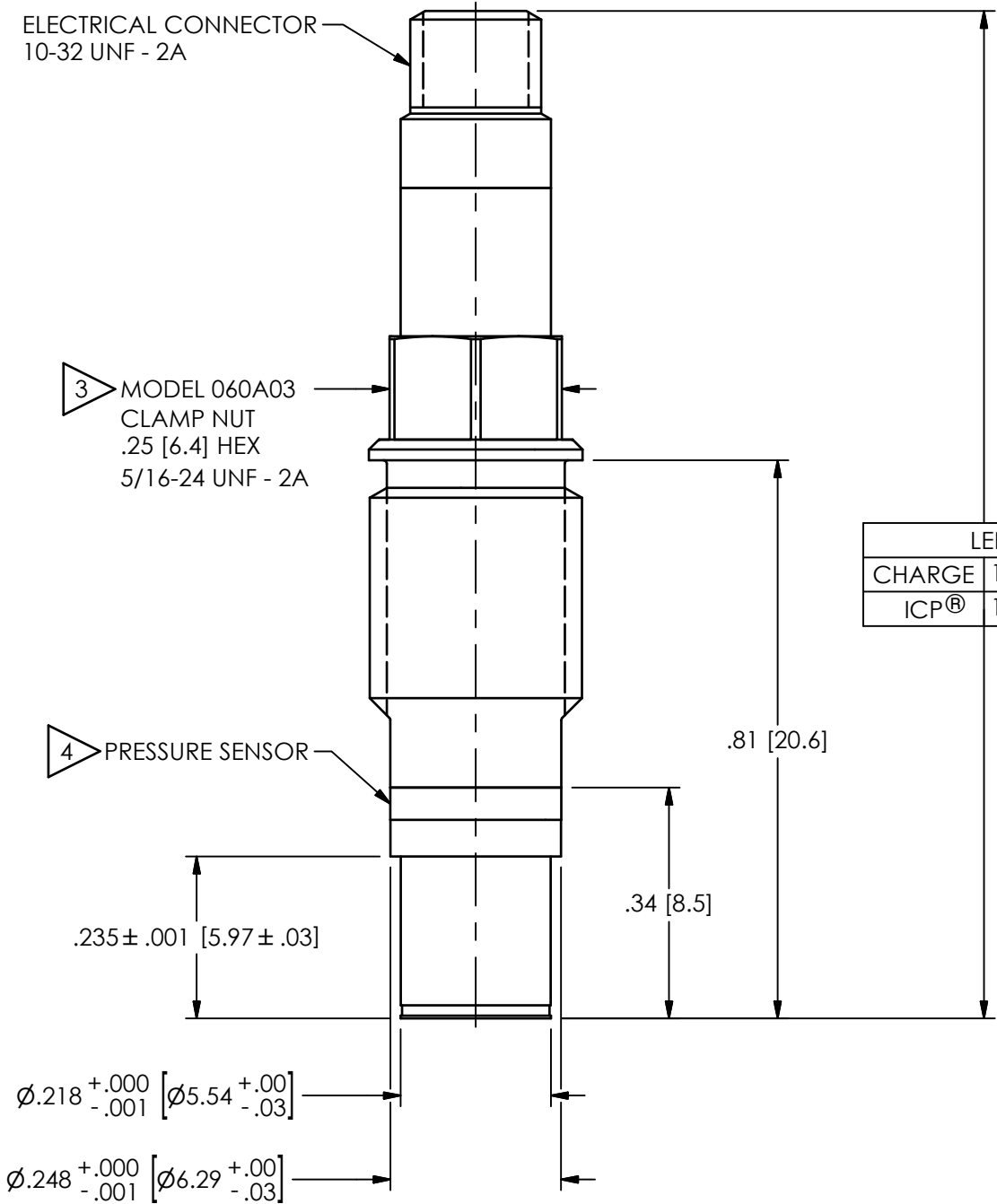

MOUNTING HOLE PREPARATION

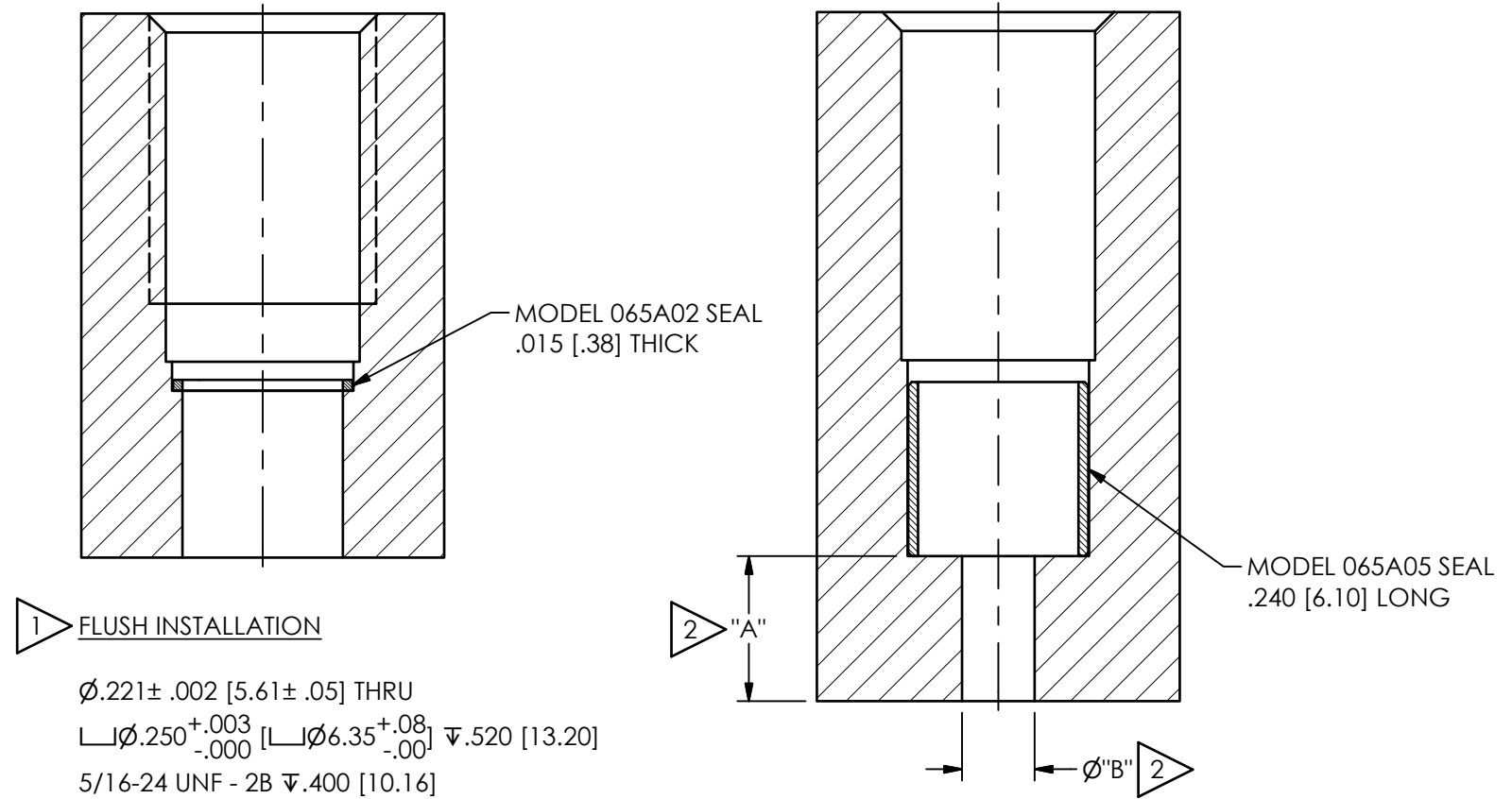

- 4 IC AMP & SENSOR ARE SEALED ASSEMBLIES & SHOULD BE RETURNED TO THE FACTORY FOR SERVICE &/OR REPAIR
- 3 RECOMMENDED TORQUE ON .25 [6.3] HEX: 25-35 IN-LBS [2.8-3.9 N-m]
- 2 DIMENSIONS "A" & "B" TO SUIT USER REQUIREMENTS
- 1 THESE DIMENSIONS FOR .750 [19.05] THICK WALL. C'BORE FOR THICKER WALLS

UNLESS OTHERWISE SPECIFIED TOLERANCES ARE:		DRAWN		CHECKED		ENGINEER	
DIMENSIONS IN INCHES		NJF	09/23/22	JDM	09/23/22	AJA	09/23/22
DECIMALS XX ±.01 XXX ±.005		TITLE					
ANGLES ± 2 DEGREES		INSTALLATION DRAWING					
CABLE TOLERANCES IN ENGLISH		ENGLISH MOUNT					
1" ≤ LENGTH < 1' = +1"/-0		MODELS 111, 112, & 113 SERIES					
1' ≤ LENGTH < 5' = +2"/-0		PRESSURE SENSOR					
5' ≤ LENGTH < 100' = +6"/-0		SCALE: 4X		SHEET 1 OF 2		PCB PIEZOTRONICS AN AMPHENOL COMPANY	
100' ≤ LENGTH = +1"/-0		DWG. NO. 40623		3425 WALDEN AVE. DEPEW, NY 14043 (716) 684-0001 E-MAIL: sales@pcb.com			
FILLETS AND RADII .003 - .005		CODE IDENT. NO. 52681					
FILLETS AND RADII 0.07 - 0.13							

PCB Piezotronics Inc. claims proprietary rights in the information disclosed hereon. Neither it nor any reproduction thereof will be disclosed to others without the written consent of PCB Piezotronics Inc.

40623

REVISIONS		
REV	DESCRIPTION	DIN
	-SEE SHEET 1-	

ELECTRICAL CONNECTOR
10-32 UNF - 2A

3 MODEL 060A05
CLAMP NUT
.25 [6.4] HEX
M7x0.75 - 6g

4 PRESSURE SENSOR

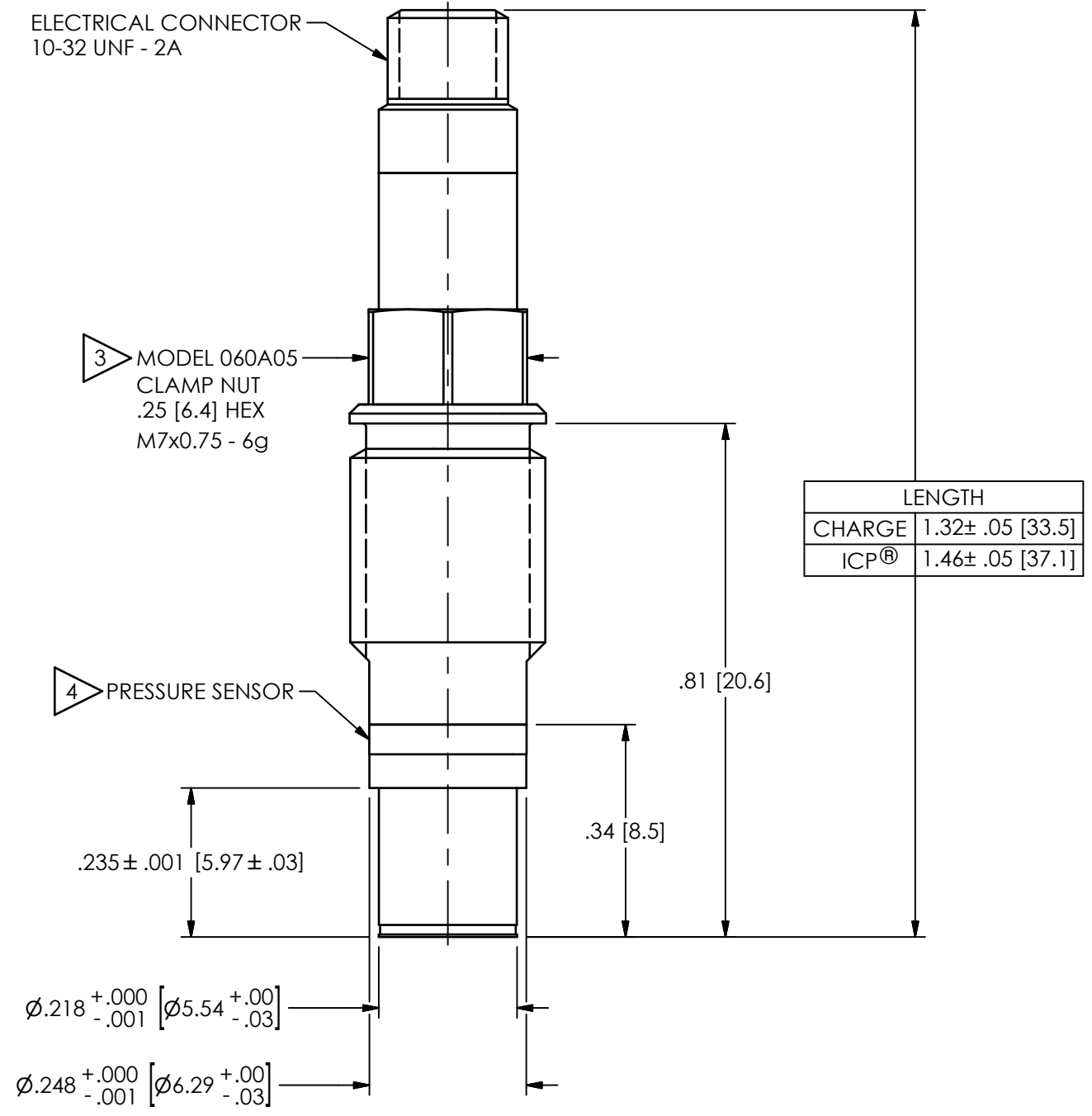

MOUNTING HOLE PREPARATION

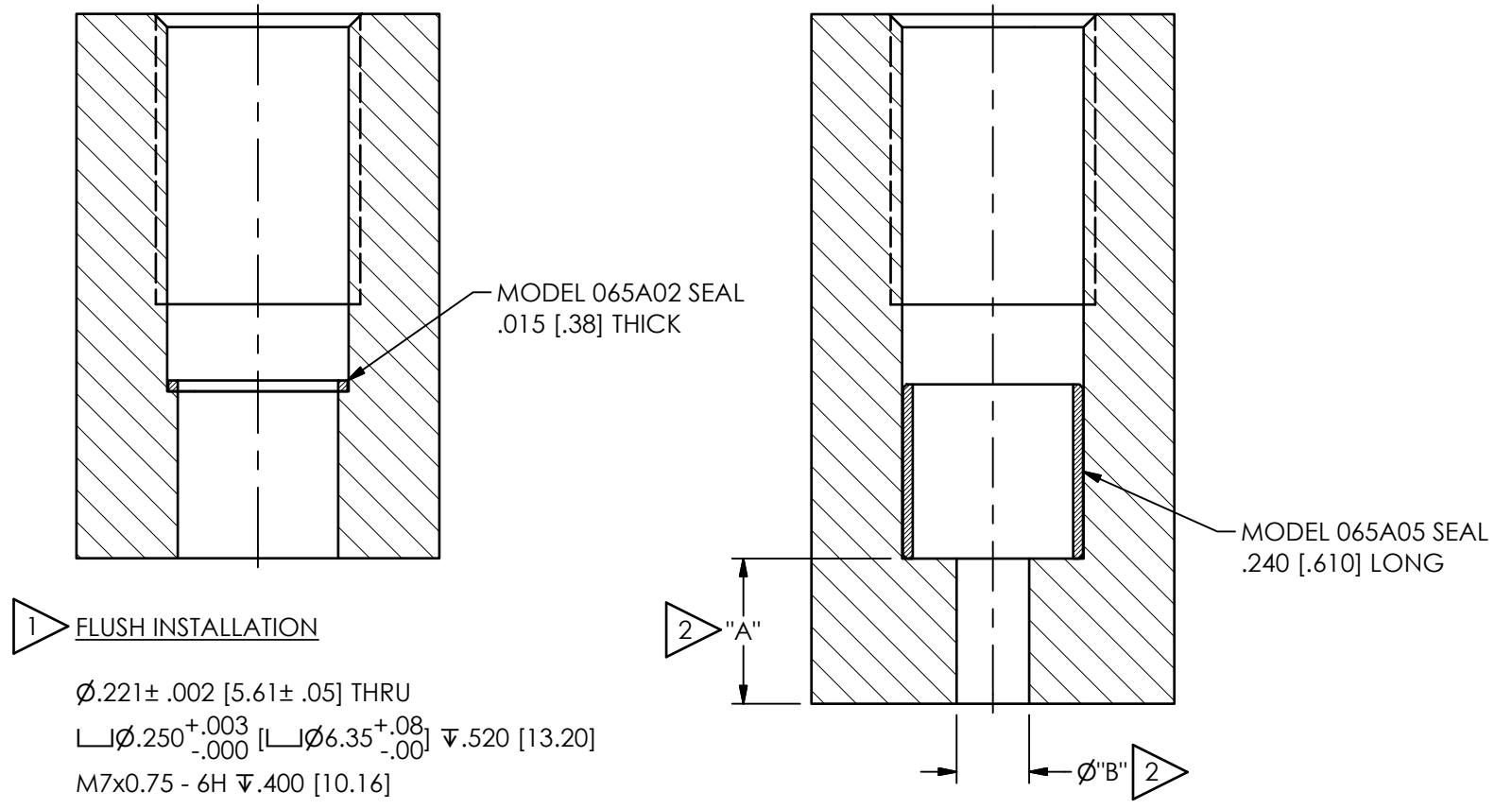

RECESSED INSTALLATION

$\perp \phi .250^{+.003}_{-.000}$ [$\perp \phi 6.35^{+.08}_{-.00}$] $\nabla .750$ [19.05]

M7x0.75 - 6H $\nabla .400$ [10.16]

- 4 IC AMP & SENSOR ARE SEALED ASSEMBLIES & SHOULD BE RETURNED TO THE FACTORY FOR SERVICE &/OR REPAIR
- 3 RECOMMENDED TORQUE ON .25 [6.3] HEX: 25-35 IN-LBS [2.8-3.9 N-m]
- 2 DIMENSIONS "A" & "B" TO SUIT USER REQUIREMENTS
- 1 THESE DIMENSIONS FOR .750 [19.05] THICK WALL. C'BORE FOR THICKER WALLS

UNLESS OTHERWISE SPECIFIED TOLERANCES ARE:		DRAWN		CHECKED		ENGINEER	
DIMENSIONS IN INCHES		NJF	09/23/22	JDM	09/23/22	AJA	09/23/22
DECIMALS XX ±.01 XXX ±.005		TITLE					
ANGLES ± 2 DEGREES		INSTALLATION DRAWING					
CABLE TOLERANCES IN ENGLISH		METRIC MOUNT					
1" ≤ LENGTH < 1' = +1' / - 0		MODELS 111, 112, & 113 SERIES					
1' ≤ LENGTH < 5' = +2' / - 0		PRESSURE SENSOR					
5' ≤ LENGTH < 100' = +6' / - 0		SCALE: 4X		SHEET 2 OF 2		PCB PIEZOTRONICS AN AMPHENOL COMPANY	
100' ≤ LENGTH = +1' / - 0		CODE IDENT. NO. 52681		DWG. NO. 40623		3425 WALDEN AVE. DEPEW, NY 14043 (716) 684-0001 E-MAIL: sales@pcb.com	
FILLETS AND RADII .003 - .005							
FILLETS AND RADII 0.07 - 0.13							