**User's
Manual**

**701992
Xviewer**

Thank you for purchasing the Xviewer (Model 701992) waveform viewer software. This User's Manual contains information on the functions and operation of the Xviewer, as well as precautions that must be observed. To ensure the correct operation of the Xviewer, read this manual thoroughly before attempting to use the product. After reading the manual, keep it in a convenient location for quick reference whenever a question arises during operation.

Furthermore, for handling precautions, functions, and operating procedures of the DL series, SL1400, SL1000, or other instruments, or for the handling and operating procedures of Windows, please see the manuals for those respective products. The following manuals, including this one, are provided as manuals for the Xviewer. Read them along with this manual.

Manual Title	Manual No.	Description
701992 Xviewer User's Manual	IM 701992-01E	This manual. Explains the Xviewer's standard features and how to use these features.
Xviewer EYE Video and Waveform Viewer Feature User's Manual	IM 701992-61E	Explains the video and waveform viewer features and how to use these features.
Xviewer DL850 Advanced Utility User's Manual	IM 701992-62E	Explains the DL850 advanced utility features and how to use these features.

Notes

- If the most recent software version is not running on your Xviewer, not all of the features described in this manual can be used. You can check the software version of your Xviewer on the version information screen. For instructions on how to open the version information screen, see section 9.2 in this manual. To upgrade to the latest software version, visit the download page at the following website.
<https://tmi.yokogawa.com/library/>
- The contents of this manual are subject to change without prior notice due to performance/functional improvements to the software or related products. The images appearing in this manual are for illustrative purposes only and may differ slightly from the screens that actually appear on your machine.
- Every effort has been made in the preparation of this manual to ensure the accuracy of its contents. However, should you have any questions or find any errors, contact your nearest YOKOGAWA dealer.
- Copying or reproducing all or any part of the contents of this manual without the permission of YOKOGAWA is strictly prohibited.

Trademarks

- Microsoft and Windows are either registered trademarks or trademarks of Microsoft Corporation in the United States and/or other countries.
- Adobe, Acrobat, and PostScript are either registered trademarks or trademarks of Adobe Systems Incorporated.
- MATLAB is a registered trademark of The MathWorks, Inc. in the United States.
- In this manual, the ® and TM symbols do not accompany their respective registered trademark names or trademark names.
- Other company names and product names are registered trademarks or trademarks of their respective holders.

Revisions

- January 2005 1st edition issued
- October 2005 3rd edition issued
- March 2007 5th edition issued
- September 2008 7th edition issued
- January 2011 9th edition issued
- September 2011 11th edition issued
- October 2012 13th edition issued
- December 2013 15th edition issued
- March 2015 17th edition issued
- June 2016 19th edition issued
- October 2017 21st edition issued
- November 2018 23rd edition issued
- July 2005 2nd edition issued
- August 2006 4th edition issued
- December 2007 6th edition issued
- September 2010 8th edition issued
- April 2011 10th edition issued
- February 2012 12th edition issued
- June 2013 14th edition issued
- June 2014 16th edition issued
- October 2015 18th edition issued
- July 2017 20th edition issued
- May 2018 22nd edition issued
- September 2020 24th edition issued

Terms and Conditions of the Software License

Yokogawa Test & Measurement Corporation, a Japanese corporation (hereinafter called "Yokogawa"), grants permission to use this Yokogawa Software Program (hereinafter called the "Licensed Software") to the Licensee on the conditions that the Licensee agrees to the terms and conditions stipulated in Article 1 hereof.

You, as the Licensee (hereinafter called "Licensee"), shall agree to the following terms and conditions for the software license (hereinafter called the "Agreement") based on the use intended for the Licensed Software.

Please note that Yokogawa grants the Licensee permission to use the Licensed Software under the terms and conditions herein and in no event shall Yokogawa intend to sell or transfer the Licensed Software to the Licensee.

Licensed Software Name: Xviewer (Model 701992) or XviewerEYE (Model 701992)
Number of Client License: The number of licenses printed on the license seal

Article 1 (Scope Covered by these Terms and Conditions)

- 1.1 The terms and conditions stipulated herein shall be applied to any Licensee who purchases the Licensed Software on the condition that the Licensee consents to agree to the terms and conditions stipulated herein.
- 1.2 The "Licensed Software" herein shall mean and include all applicable programs and documentation, without limitation, all proprietary technology, algorithms, and know-how such as a factor, invariant or process contained therein.

Article 2 (Grant of License)

- 2.1 Yokogawa grants the Licensee, for the purpose of single use, non-exclusive and non-transferable license of the Licensed Software with the license fee separately agreed upon by both parties. Yokogawa allows the Licensee to use only one instance of the software for use on one device, whether that device is physical or virtual. If the Licensee want to use the software on more than one virtual device, the Licensee must obtain a separate Licensed Software for each instance.
- 2.2 The Licensee is, unless otherwise agreed in writing by Yokogawa, not entitled to copy, change, sell, distribute, transfer, or sublicense the Licensed Software.
- 2.3 The Licensed Software shall not be copied in whole or in part except for keeping one (1) copy for back-up purposes. The Licensee shall secure or supervise the copy of the Licensed Software by the Licensee itself with great, strict, and due care.
- 2.4 In no event shall the Licensee dump, reverse assemble, reverse compile, or reverse engineer the Licensed Software so that the Licensee may translate the Licensed Software into other programs or change it into a man-readable form from the source code of the Licensed Software. Unless otherwise separately agreed by Yokogawa, Yokogawa shall not provide the Licensee the source code for the Licensed Software.
- 2.5 The Licensed Software and its related documentation shall be the proprietary property or trade secret of Yokogawa or a third party which grants Yokogawa the rights. In no event shall the Licensee be transferred, leased, sublicensed, or assigned any rights relating to the Licensed Software.
- 2.6 Yokogawa may use or add copy protection in or onto the Licensed Software. In no event shall the Licensee remove or attempt to remove such copy protection.
- 2.7 The Licensed Software may include a software program licensed for re-use by a third party (hereinafter called "Third Party Software", which may include any software program from affiliates of Yokogawa made or coded by themselves.) In the case that Yokogawa is granted permission to sublicense to third parties by any licensors (sub-licensors) of the Third Party Software pursuant to different terms and conditions than those stipulated in this Agreement, the Licensee shall observe such terms and conditions of which Yokogawa notifies the Licensee in writing separately.
- 2.8 Yokogawa software products may contain open source software (hereafter referred to as OSS). For the OSS, terms and conditions provided separately apply with higher precedence than those of this agreement.

Article 3 (Restriction of Specific Use)

- 3.1 The Licensed Software shall not be intended specifically to be designed, developed, constructed, manufactured, distributed or maintained for the purpose of the following events:
 - a) Operation of any aviation, vessel, or support of those operations from the ground,;
 - b) Operation of nuclear products and/or facilities,;
 - c) Operation of nuclear weapons and/or chemical weapons and/or biological weapons; or
 - d) Operation of medical instrumentation directly utilized for humankind or the human body.
- 3.2 Even if the Licensee uses the Licensed Software for the purposes in the preceding Paragraph 3.1, Yokogawa has no liability to or responsibility for any demand or damage arising out of the use or operations of the Licensed Software, and the Licensee agrees, on its own responsibility, to solve and settle the claims and damages and to defend, indemnify or hold Yokogawa totally harmless, from or against any liabilities, losses, damages and expenses (including fees for recalling the Products and reasonable attorney's fees and court costs), or claims arising out of and related to the above-said claims and damages.

Article 4 (Warranty)

- 4.1 The Licensee shall agree that the Licensed Software shall be provided to the Licensee on an "as is" basis when delivered. If defect(s), such as damage to the medium of the Licensed Software, attributable to Yokogawa is found, Yokogawa agrees to replace, free of charge, any Licensed Software on condition that the defective Licensed Software shall be returned to Yokogawa's specified authorized service facility within seven (7) days after opening the Package at the Licensee's expense. As the Licensed Software is provided to the Licensee on an "as is" basis when delivered, in no event shall Yokogawa warrant that any information on or in the Licensed Software, including without limitation, data on computer programs and program listings, be completely accurate, correct, reliable, or the most updated.
- 4.2 Notwithstanding the preceding Paragraph 4.1, when third party software is included in the Licensed Software, the warranty period and terms and conditions that apply shall be those established by the provider of the third party software.
- 4.3 When Yokogawa decides in its own judgement that it is necessary, Yokogawa may from time to time provide the Licensee with Revision upgrades and Version upgrades separately specified by Yokogawa (hereinafter called "Updates").
- 4.4 Notwithstanding the preceding Paragraph 4.3, in no event shall Yokogawa provide Updates where the Licensee or any third party conducted renovation or improvement of the Licensed Software.
- 4.5 THE FOREGOING WARRANTIES ARE EXCLUSIVE AND IN LIEU OF ALL OTHER WARRANTIES OF QUALITY AND PERFORMANCE, WRITTEN, ORAL, OR IMPLIED, AND ALL OTHER WARRANTIES INCLUDING ANY IMPLIED WARRANTIES OF MERCHANTABILITY OR FITNESS FOR A PARTICULAR PURPOSE ARE HEREBY DISCLAIMED BY YOKOGAWA AND ALL THIRD PARTIES LICENSING THIRD PARTY SOFTWARE TO YOKOGAWA.
- 4.6 Correction of nonconformity in the manner and for the period of time provided above shall be the Licensee's sole and exclusive remedy for any failure of Yokogawa to comply with its obligations and shall constitute fulfillment of all liabilities of Yokogawa and any third party licensing the Third Party Software to Yokogawa (including any liability for direct, indirect, special, incidental or consequential damages) whether in warranty, contract, tort (including negligence but excluding willful conduct or gross negligence by Yokogawa) or otherwise with respect to or arising out of the use of the Licensed Software.

Article 5 (Infringement)

- 5.1 If and when any third party should demand injunction, initiate a law suit, or demand compensation for damages against the Licensee under patent right (including utility model right, design patent, and trade mark), copy right, and any other rights relating to any of the Licensed Software, the Licensee shall notify Yokogawa in writing to that effect without delay.
- 5.2 In the case of the preceding Paragraph 5.1, the Licensee shall assign to Yokogawa all of the rights to defend the Licensee and to negotiate with the claiming party. Furthermore, the Licensee shall provide Yokogawa with necessary information or any other assistance for Yokogawa's defense and negotiation. If and when such a claim should be attributable to Yokogawa, subject to the written notice to Yokogawa stated in the preceding Paragraph 5.1, Yokogawa shall defend the Licensee and negotiate with the claiming party at Yokogawa's cost and expense and be responsible for the final settlement or judgment granted to the claiming party in the preceding Paragraph 5.1.
- 5.3 When any assertion or allegation of the infringement of the third party's rights defined in Paragraph 5.1 is made, or when at Yokogawa's judgment there is possibility of such assertion or allegation, Yokogawa will, at its own discretion, take any of the following countermeasures at Yokogawa's cost and expense.
 - a) To acquire the necessary right from a third party which has lawful ownership of the right so that the Licensee will be able to continue to use the Licensed Software;
 - b) To replace the Licensed Software with an alternative one which avoids the infringement; or
 - c) To remodel the Licensed Software so that the Licensed Software can avoid the infringement of such third party's right.
- 5.4 If and when Yokogawa fails to take either of the countermeasures as set forth in the preceding subparagraphs of Paragraph 5.3, Yokogawa shall indemnify the Licensee only by paying back the price amount of the Licensed Software which Yokogawa has received from the Licensee. THE FOREGOING PARAGRAPHS STATE THE ENTIRE LIABILITY OF YOKOGAWA AND ANY THIRD PARTY LICENSING THIRD PARTY SOFTWARE TO YOKOGAWA WITH RESPECT TO INFRINGEMENT OF THE INTELLECTUAL PROPERTY RIGHTS INCLUDING BUT NOT LIMITED TO, PATENT AND COPYRIGHT.
- 5.5 Regardless of this article, the terms and conditions provided separately apply to demands for compensation or the like arising from the use of the Third-Party Software or OSS.

Terms and Conditions of the Software License

Article 6 (Liabilities)

- 6.1 If and when the Licensee should incur any damage relating to or arising out of the Licensed Software or service that Yokogawa has provided to the Licensee under the conditions herein due to a reason attributable to Yokogawa, Yokogawa shall take actions in accordance with this Agreement. However, in no event shall Yokogawa be liable or responsible for any special, incidental, consequential and/or indirect damage, whether in contract, warranty, tort, negligence, strict liability, or otherwise, including, without limitation, loss of operational profit or revenue, loss of use of the Licensed Software, or any associated products or equipment, cost of capital, loss or cost of interruption of the Licensee's business, substitute equipment, facilities or services, downtime costs, delays, and loss of business information, or claims of customers of Licensee or other third parties for such or other damages. Even if Yokogawa is liable or responsible for the damages attributable to Yokogawa and to the extent of this Article 6, Yokogawa's liability for the Licensee's damage shall not exceed the price amount of the Licensed Software or service fee which Yokogawa has received. Please note that Yokogawa shall be released or discharged from part or all of the liability under this Agreement if the Licensee modifies, remodels, combines with other software or products, or causes any deviation from the basic specifications or functional specifications, without Yokogawa's prior written consent.
- 6.2 All causes of action against Yokogawa arising out of or relating to this Agreement or the performance or breach hereof shall expire unless Yokogawa is notified of the claim within one (1) year of its occurrence.
- 6.3 In no event, regardless of cause, shall Yokogawa assume responsibility for or be liable for penalties or penalty clauses in any contracts between the Licensee and its customers.

Article 7 (Limit of Export)

Unless otherwise agreed by Yokogawa, the Licensee shall not directly or indirectly export or transfer the Licensed Software to any countries other than those where Yokogawa permits export in advance.

Article 8 (Term)

This Agreement shall become effective on the date when the Licensee receives the Licensed Software and continues in effect unless or until terminated as provided herein, or the Licensee ceases using the Licensed Software by itself or with Yokogawa's thirty (30) days prior written notice to the Licensee.

Article 9 (Injunction for Use)

During the term of this Agreement, Yokogawa may, at its own discretion, demand injunction against the Licensee in case that Yokogawa deems that the Licensed Software is used improperly or under severer environments other than those where Yokogawa has first approved, or any other condition which Yokogawa may not permit.

Article 10 (Termination)

Yokogawa, at its sole discretion, may terminate this Agreement without any notice or reminder to the Licensee if the Licensee violates or fails to perform this Agreement. However, Articles 5, 6, and 11 shall survive even after the termination.

Article 11 (Jurisdiction)

Any dispute, controversies, or differences between the parties hereto as to interpretation or execution of this Agreement shall be resolved amicably through negotiation between the parties upon the basis of mutual trust. Should the parties fail to agree within ninety (90) days after notice from one of the parties to the other, both parties hereby irrevocably submit to the exclusive jurisdiction of the Tokyo District Court (main office) in Japan for settlement of the dispute.

Article 12 (Governing Law)

This Agreement shall be governed by and construed in accordance with the laws of Japan. The Licensee expressly agrees to waive absolutely and irrevocably and to the fullest extent permissible under applicable law any rights against the laws of Japan which it may have pursuant to the Licensee's local law.

Article 13 (Severability)

In the event that any provision hereof is declared or found to be illegal by any court or tribunal of competent jurisdiction, such provision shall be null and void with respect to the jurisdiction of that court or tribunal and all the remaining provisions hereof shall remain in full force and effect.

Article 14 (Change in Agreement)

The contents of this contract, contents of this product, specifications of the licensed software, related support and other related services can be changed at Yokogawa's discretion.

Checking the Contents of the Package

After opening the package, check that it contains the items listed below. If any of the contents are incorrect, missing, or damaged, contact the dealer from whom you purchased it.

CD × 1

Model	Suffix Code	Description
701992		Xviewer
Grade/Number of Licenses	-SP01	Standard edition (1 license)
	-SP05	Standard edition (5 licenses)
	-SP10	Standard edition (10 licenses)
	-SP20	Standard edition (20 licenses)
	-GP01	Math edition (1 license)
	-GP05	Math edition (5 licenses)
	-GP10	Math edition (10 licenses)
	-GP20	Math edition (20 licenses)
	-ES01	XviewerEYE standard edition (1 license)
	-ES02	XviewerEYE standard edition (2 licenses)
	-ES03	XviewerEYE standard edition (3 licenses)
	-ES04	XviewerEYE standard edition (4 licenses)
	-ES05	XviewerEYE standard edition (5 licenses)
	-ES10	XviewerEYE standard edition (10 licenses)
	-EG01	XviewerEYE math edition (1 license)
	-EG02	XviewerEYE math edition (2 licenses)
	-EG03	XviewerEYE math edition (3 licenses)
	-EG04	XviewerEYE math edition (4 licenses)
	-EG05	XviewerEYE math edition (5 licenses)
	-EG10	XviewerEYE math edition (10 licenses)
	/JS01	DL850 Advanced Utility (1 license)
	/JS02	DL850 Advanced Utility (2 licenses)
	/JS03	DL850 Advanced Utility (3 licenses)
	/JS04	DL850 Advanced Utility (4 licenses)
	/JS05	DL850 Advanced Utility (5 licenses)
	/JS10	DL850 Advanced Utility (10 licenses)
	/JS20	DL850 Advanced Utility (20 licenses)

Manuals

Manual Title	Manual No.
701992 Xviewer User's Manual (Located on the CD)	IM 701992-01E
701992 Xviewer Install Manual	IM 701992-02E
701992 XviewerEYE Video and Waveform Viewer Feature User's Manual (Located on the CD)	IM 701992-61E
Xviewer DL850 Advanced Utility User's Manual (Located on the CD)	IM 701992-62E

License seal × 1

(for /JS01 to JS20: license seal x 2)

Symbols and Notations Used in This Manual

Marking

The following marking is used in this manual

Note

Calls attention to information that is important for proper operation of the instrument.

Notation Used in the Procedural Explanations

On pages that describe the operating procedures in each chapter, the following notations are used to distinguish the procedures from their explanations.

Procedure

Carry out the procedure according to the step numbers. All procedures are written with inexperienced users in mind; experienced users may not need to carry out all the steps.

Explanation

This section describes the setup items and the limitations regarding the procedures.

Notation in Boldface

Boldface type indicates the names of user-controlled panel keys, and soft key items and menu items displayed on screen.

Contents

Terms and Conditions of the Software License.....	iii
Checking the Contents of the Package.....	v
Symbols and Notations Used in This Manual	vi
Product Overview.....	ix
Important Notice.....	xi
Installing/Uninstalling Xviewer	xii
Chapter 1 Basic Operations	
1.1 Starting and Closing Xviewer	1-1
1.2 Basic Operations Performed From the Startup Windows.....	1-2
1.3 Setting the Language	1-4
Chapter 2 Displaying Waveform Data	
2.1 Loading Waveform Data.....	2-1
2.2 Displaying Waveforms in the Main View	2-6
2.3 Displaying Waveforms in a Zoomed View	2-7
2.4 Displaying Waveforms in the History View	2-9
2.5 Displaying a Waveform in the X-Y View	2-11
2.6 Moving or Zooming Waveforms.....	2-13
2.7 Splitting the Screen	2-15
2.8 Displaying Waveforms Acquired with the DL850 series Dual Capture Function.....	2-16
2.9 Switching between Groups.....	2-17
2.10 Showing Marks.....	2-18
2.11 Displaying Waveform Properties	2-19
Chapter 3 Specifying Display Settings for Waveform Data	
3.1 Loading Display Settings.....	3-1
3.2 Setting Waveforms (Channels) to be Displayed.....	3-2
3.3 Specifying Split Settings.....	3-9
3.4 Specifying Display Settings	3-10
3.5 Turning Waveform Interpolation On and Off.....	3-15
3.6 Initializing Display Settings.....	3-16
Chapter 4 Analyzing Waveform Data	
4.1 Displaying Measurement Results.....	4-1
4.2 Analyzing Waveform Data Using Cursors	4-2
4.3 Automated Measurement of Waveform.....	4-5
4.4 Automated Measurement of History Statistics	4-11
4.5 Automated Measurement of Cycle Statistics.....	4-14
4.6 Analyzing Waveforms by Computations (Math Edition)	4-18
4.7 Inserting Annotations in the Waveform View	4-30
4.8 Transferring a Waveform View to the Clipboard.....	4-44

1

2

3

4

5

6

7

8

9

10

Index

Chapter 5 Saving Data/Converting Data Formats

5.1	Saving Waveform Data.....	5-1
5.2	Transferring Waveform Data into Excel.....	5-8
5.3	Saving Waveform Data in a View	5-10
5.4	Saving Automated Measurement Values forWaveform Parameters	5-11
5.5	Saving the Display Settings.....	5-12
5.6	Converting Multiple Waveform Data Files to CSV Files	5-13
5.7	Converting WDF Files to WVF Files.....	5-15
5.8	Converting WDF/WVF Files to FLD Files	5-17

Chapter 6 Printing Waveforms in the Displayed View

6.1	Setting Up a Printer	6-1
6.2	Printing Displayed Waveforms	6-2

Chapter 7 Report Function

7.1	Using the Report Function (Xreport)	7-1
7.2	Editing Reports.....	7-4
7.3	Saving, Loading, or Deleting Report Files	7-8
7.4	Printing Reports.....	7-10

Chapter 8 Communicating with the Instruments

8.1	Connecting to the Instruments	8-1
8.2	Displaying a File List	8-5
8.3	Manipulating Files	8-7
8.4	Operating the Instruments from a PC.....	8-10
8.5	Downloading the Instruments Waveform Data	8-21

Chapter 9 Troubleshooting

9.1	Troubleshooting.....	9-1
9.2	Viewing Version Information.....	9-2
9.3	Starting Online Help	9-3
9.4	Visiting the Yokogawa Web Page.....	9-4
9.5	Adding a License Number	9-5

Chapter 10 Specifications

10.1	Applicable Models and Features	10-1
10.2	System Environment Requirements.....	10-3
10.3	Software Versions and the Added Functions.....	10-4

Index

Product Overview

Waveform Viewer Xviewer

Viewing and Analyzing Data Saved with the Instruments

You can view and analyze data saved with the measuring instruments on a personal computer (hereinafter, PC).

The formats of the files saved by the measuring instruments are as follows.

Model	File Types (filename extension)				
	CSV ¹ (.csv)	WVF ² (.wvf)	WDF ² (.wdf)	WDF ³ (.wdf)	MAT ⁴ (.mat)
WE7000	Yes	Yes	No	No	No
DL1700 series	Yes	Yes	No	No	No
DL1600 series	Yes	Yes	No	No	No
DL1700E series	Yes	Yes	No	No	No
DL7400 series	Yes	Yes	No	No	No
DL750 series	Yes	Yes	No	Yes	No
DL9040/DL9140/DL9240 series	Yes	No	Yes	No	No
DL9500/DL9700 series	Yes	No	Yes	No	No
DL6000/DLM6000 series	Yes	No	Yes	No	No
SB5000 series	Yes	No	Yes	No	No
SL1000	No	No	Yes	Yes	No
SL1400	Yes	Yes	No	Yes	No
DLM2000 series	Yes	No	Yes	No	No
DLM3000 series	Yes	No	Yes	No	No
DLM4000 series	Yes	No	Yes	No	No
DLM5000 series	Yes	No	Yes	No	No
DL850 series	Yes	No	Yes	Yes	Yes
DL350 series	Yes	No	Yes	No	Yes

1 Files created and saved in ASCII format

2 Files created and saved in binary format

3 Files created with real-time recording

4 Files saved as MATLAB format

This document refers to the DL9040/DL9140/DL9240 series, and the DL9500/DL9700 series collectively as the "DL9000 series".

Viewing and Transferring Files Saved with the Instruments

Xviewer supports the viewing of the instrument files as well as the transfer of files between the instrument and your PC by using the GP-IB/USB/Ethernet interface. The communication interfaces and functions that can be used are shown on the next page.

Note

Xviewer file transfer from your PC to the instrument is possible only via the USB interface.

Remote Control of the Instruments

With the GP-IB/USB/Ethernet interface, Xviewer supports the display of images (control windows) from the instrument on your PC, as well as the remote-control of the instrument as if you were operating the unit from its own control panel. In addition, to enable the setup of a control window environment, Xviewer features Environment Setting Keys, which are not found on the DL unit.

The communication interfaces and functions that can be used are shown on the next page.

Downloading the Instruments Acquisition Data

The instrument acquisition data can be downloaded to a PC using the GP-IB, USB, or Ethernet interface.

The communication interfaces and functions that can be used are shown on the next page.

Available communication interface

Model	Interface		
	GP-IB	USB	Ethernet
WE7000	No	No	No
DL1700 series	No	No	No
DL1600 series	Yes	Yes	Yes
DL1700E series	Yes	Yes	Yes
DL7400 series	Yes	Yes	Yes
DL750 series	Yes	Yes	Yes
SL1400	Yes	Yes	Yes
DL9040/DL9140/DL9240 series	Yes	Yes ¹	Yes
DL9500/DL9700 series	Yes	Yes ¹	Yes
SB5000 series	Yes	Yes ¹	Yes
SL1000	No	Yes ¹	Yes ²
DLM2000 series	Yes	Yes ¹	Yes ²
DL6000/DLM6000 series	Yes	Yes ¹	Yes ²
DL850 series	Yes	Yes ¹	Yes ²
DLM4000 series	Yes	Yes ¹	Yes ²
DL350 series	No	Yes ¹	Yes ²
DLM3000 series	Yes	Yes ¹	Yes ²
DLM5000 series	Yes	Yes ¹	Yes ²

1 Control by USB-TMC

2 Control by VXI11

Available function

Model	Communication Function		
	Viewing and Transferring Files	Remote Control	Downloading Acquisition Data
WE7000	No	No	No
DL1700 series	No	No	No
DL1600 series	Yes Version 1.12 or later	Yes Version 1.12 or later	Yes Version 1.30 or later
DL1700E series	Yes	Yes	Yes Version 2.11 or later
DL7400 series	Yes Version 1.23 or later	Yes Version 1.23 or later	Yes Version 2.11 or later
DL750 series	Yes Version 2.50 or later	Yes Version 2.50 or later	Yes Version 6.01 or later
SL1400	Yes	Yes	Yes
DL9040/DL9140/DL9240 series	Yes Version 1.80 or later	Yes Version 1.64 or later	Yes Version 1.80 or later
DL9500/DL9700 series	Yes	Yes	Yes
SB5000 series	Yes	Yes	Yes
SL1000	Yes	No	No
DLM2000 series	Yes	Yes	Yes
DL6000/DLM6000 series	Yes	Yes	Yes
DL850 series	Yes	Yes	Yes
DLM4000 series	Yes	Yes	Yes
DL350 series	Yes	Yes	Yes
DLM3000 series	Yes	Yes	Yes
DLM5000 series	Yes	Yes	Yes

System Environment Requirements

See section 10.2

Important Notice

Keep the Original CD-ROM Safe

Keep the original Xviewer CD-ROM in a safe place. Normally, the software should be installed onto and run from a hard drive.

Precautions on the Use of Xviewer

- When you are using Xviewer, do not attempt to manipulate the instruments connected to it; the units may malfunction
- Xviewer may be unable to operate if the PC goes into standby mode. Disable standby mode on your PC before starting up Xviewer.
- If you start this software program when using the Ethernet interface, the line load will differ depending on the measuring instrument used. For details, see section 8.1. Check with your network administrator as to whether these traffic loads can be handled by your network.
- Do not attempt to use Xviewer to alter the network or communication settings of the connected the instruments. Doing so may lead to a communication failure between the instruments.
- Do not attempt any self-tests with Xviewer.
- One Xviewer instance can control only one instrument. In addition, multiple PCs cannot be connected to a single instrument.
- Xviewer does not support the thumbnail previews offered by the DL1600/DL1700E series. Also, Xviewer does not support the thumbnails or previews offered by the DL7400 series.
- In the event of a connection error with the instrument, power off the instrument, and then turn it on again.

Installing/Uninstalling Xviewer

Procedure

Installing Xviewer

The steps below assume the use of Windows 7.

1. Turn on your PC, log on with the Administrator account, then wait for Windows to start up.
2. Place the Xviewer CD-ROM in the PC's CD-ROM drive. The Xviewer Installer starts automatically and begins to prepare the installation.
3. Follow the displayed instructions and then click **Next**.
4. The Agreements screen is displayed and prompts you to indicate whether you agree with the conditions of use for the software. Once you have read and agreed to the conditions of use, place a check mark against **I Agree with the Conditions of Use** and then click **Next**.
5. A screen for entering user information is displayed. Enter the **User Name**, **Organization**, and **License Number**, specify the users who will be allowed to use Xviewer, and then click **Next**. The license number can be found on a label applied to the outside of the CD-ROM case.

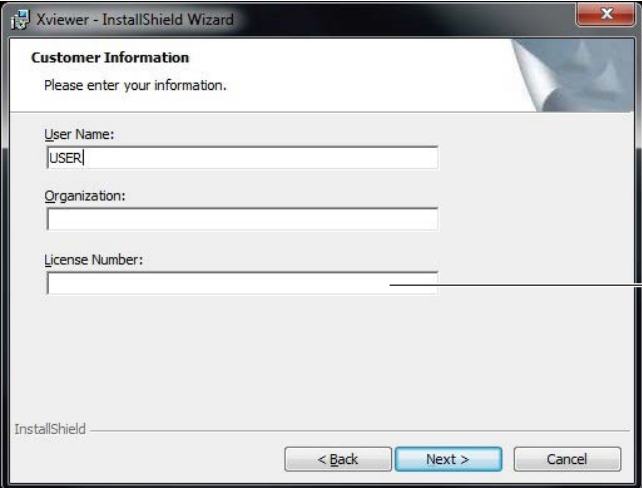

Enter the license number printed on the installation disk package

6. A product information screen is displayed. Click **Next**.

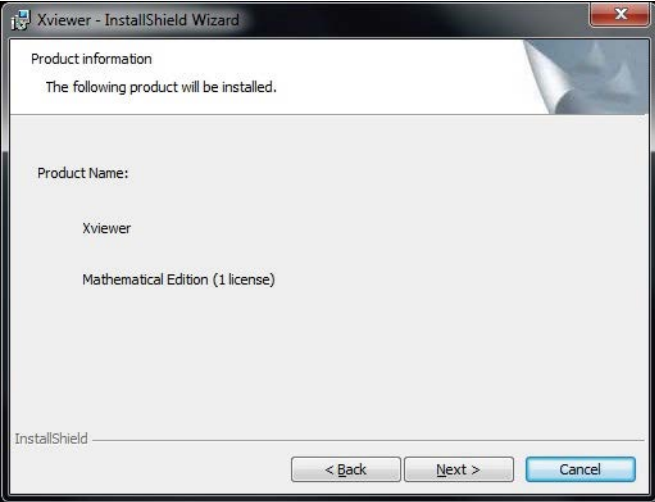

- The installation folder screen is displayed. The default setting is C:\Program Files\Yokogawa\Xviewer. To specify a different installation folder, click **Browse**. After specifying the installation folder, click **Next**.

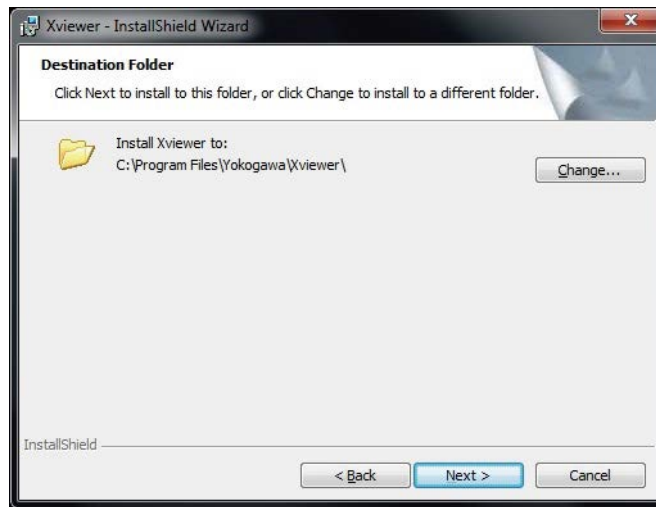

- The installation start screen is displayed. Click **Install** to start installing Xviewer. The Installer starts the installation of Xviewer.

To return to the previous screen and change installation settings, click **Back**. To cancel the installation, click **Cancel**.

The User Account Control screen will appear part way through the installation. Click **Allow** to continue with the installation.



If the software installation finishes normally, the following screen appears.

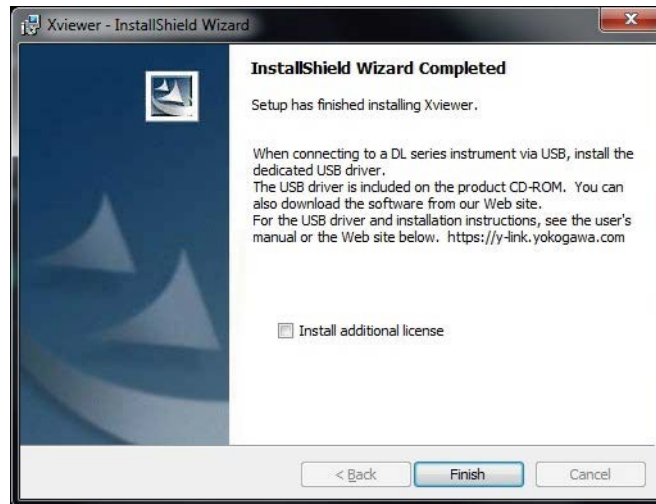

9. Click **Finish** to close the Installer. A Yokogawa > Xviewer selection will be available when you click Start > Programs and a shortcut icon to Xviewer will appear on the desktop.

Note

If an older version of Xviewer is already installed on the PC, you must uninstall that version before proceeding with the installation of the new one.

Uninstalling Xviewer

The steps below assume the use of Windows 7.

1. Select **Control Panel** from the Start menu.
2. Double-click **Programs and Features** on Control Panel.
3. Select **Xviewer** in the list displayed for Programs and Features, and then click **Uninstall/Change**.
4. A screen appears asking you to confirm whether you want to delete Xviewer. Click **Yes** to proceed. Xviewer is removed from your PC. Click **No** to cancel.

The User Account Control screen will appear part way through the uninstallation. Click **Allow** to continue with the uninstallation.

Explanation**USB Driver**

To establish a USB connection with the DL series unit, Xviewer requires that the USB driver(YKMUSB/YTUSB) or IVI driver(VISA) be installed for that DL series unit. The USB driver is included in the Xviewer installation disk. For details on the latest dedicated USB driver, visit the download page at the following website.

<https://tmi.yokogawa.com/library/>

- **Install the YKMUSB/YTUSB Driver**

Run the **Setup.exe** file in the YKMUSB/YTUSB folder. The installation wizard starts. For the details of the installation procedure, please see the manual in the YKMUSB/YTUSB folder.

1.1 Starting and Closing Xviewer

Procedure

Starting Xviewer

From the Windows **Start** menu, select **Programs > Yokogawa > Xviewer > Xviewer**. Xviewer starts up and displays the Xviewer toolbar, controller window, and viewer window, as shown below:

Xviewer toolbar

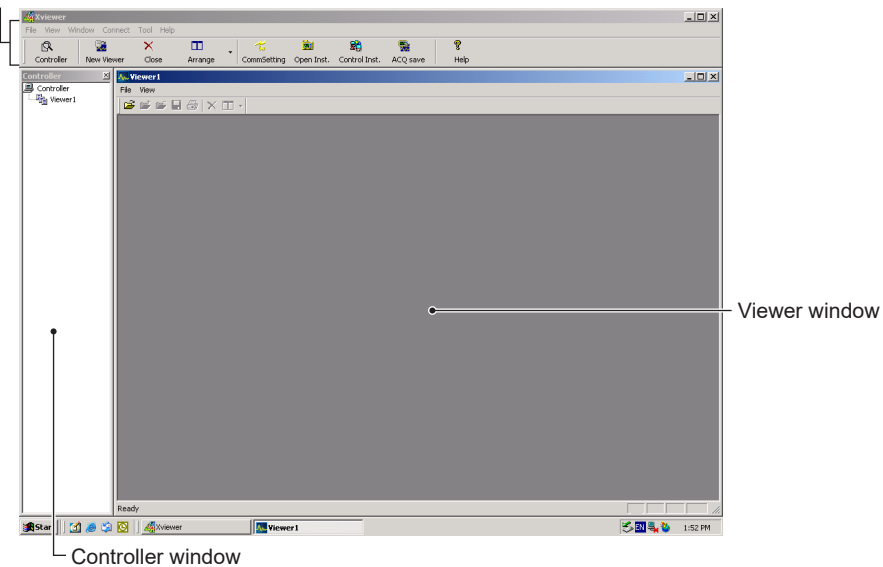

Closing Xviewer

Select **File > Close Xviewer** from the Xviewer toolbar.

Note

If the extension of the waveform data files is as follows, you can double-click the file to start Xviewer and display the waveform on the viewer.

- wvf
- wdf

1.2 Basic Operations Performed From the Startup Windows

Procedure

Xviewer toolbar:

Used to manipulate the controller window and viewer windows and to control the connection with the instrument.

Controller window:

Used to make one of the displayed viewer windows active.

Viewer window:

Used to load, display, and analyze waveform data. Multiple viewer windows can be displayed and used to load, display, and analyze waveform data in the respective viewer windows.

Xviewer toolbar

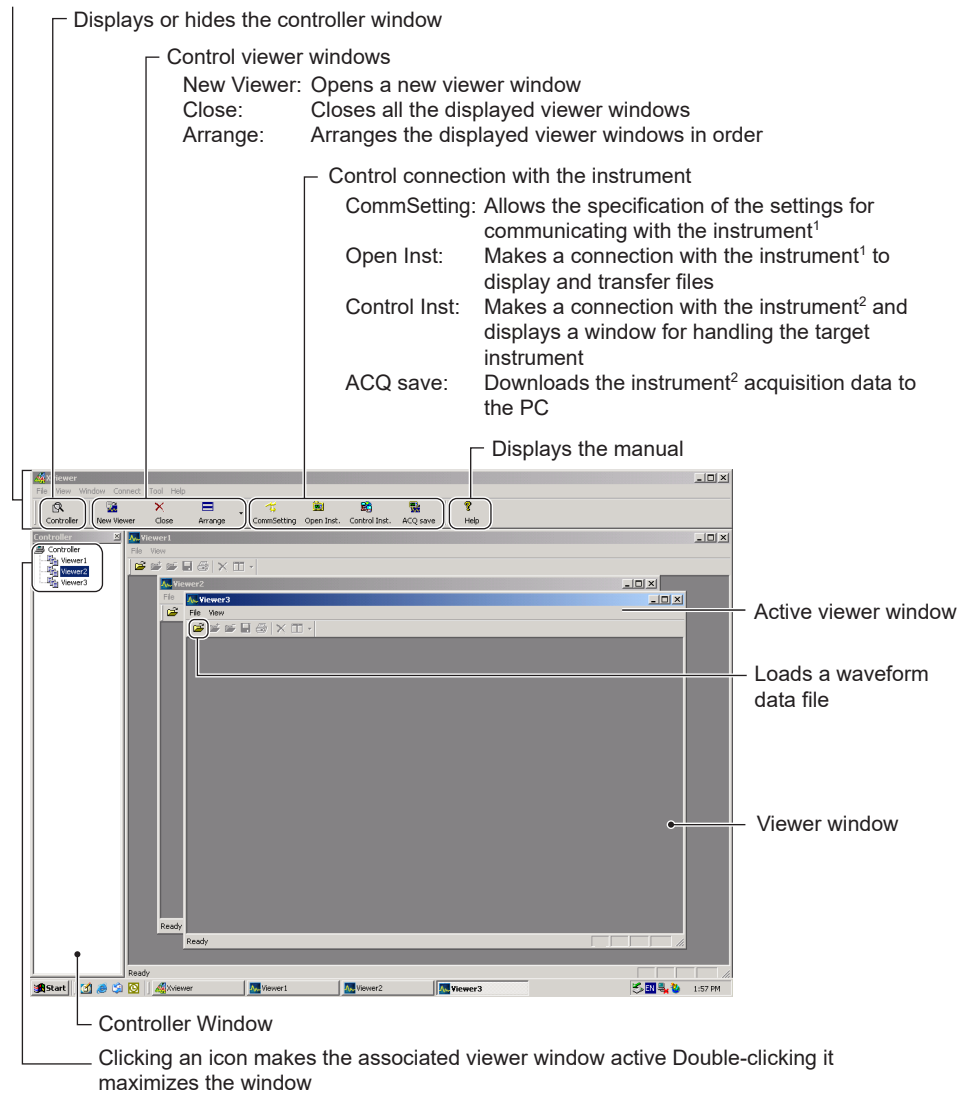

1 DL750 series, DL9000 series, SB5000 series, DL7400 series, DL1700E series, DL1600 series, SL1400, and SL1000

2 DL750 series, DL9000 series, SB5000 series, DL7400 series, DL1700E series, DL1600 series, and SL1400

Explanation

Types of Viewer Window

There are five types of viewer window:

- **Main waveform display window:** Displays all of the loaded waveform data.
- **Zoom waveform display window:** Zooms the loaded waveform data.
- **History waveform display window:** Displays all the waveform data records obtained by means of the sequential store, single (N) trigger mode, and/or history feature.
- **X-Y waveform display window:** Plots a channel (trace) in the main/zoom window as an X-Y view.
- **Measurement result display window:** Measured values such as cursor measurements, automatic measurements, and measurements through computation are displayed as numerical values.

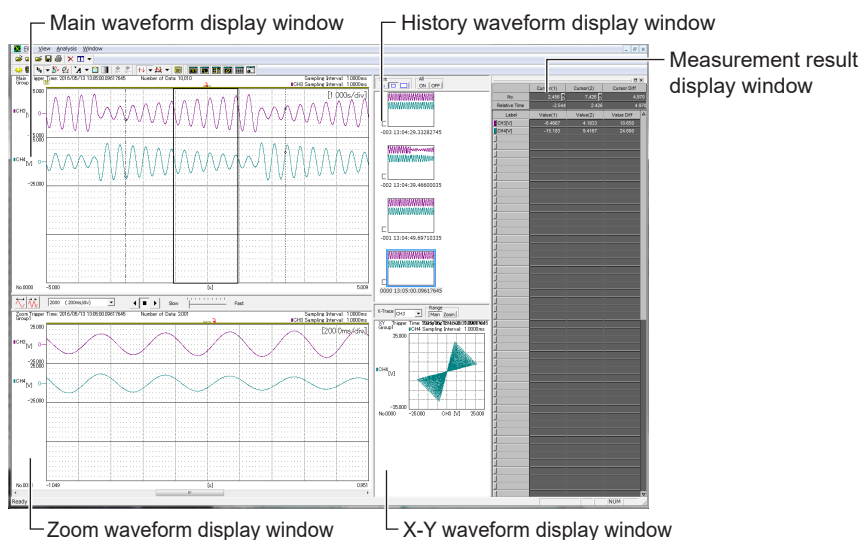

Resizable Windows

By dragging the borders of the Xviewer toolbar, Controller window, and Viewer window, you can change the size of the window arbitrarily.

Click **Arrange** on the tool bar to adjust the size of the Viewer window according to that of the Xviewer toolbar and Controller window.

1.3 Setting the Language

Procedure

1. From the toolbar, select **Help > Language**. From the list of languages that appears, select the language you want to use.

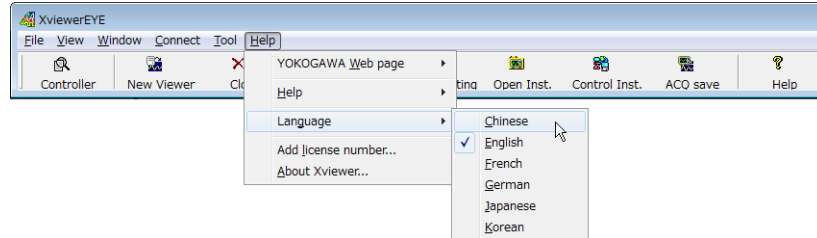

2. Restart the software.

Explanation

You can set the language displayed on the screen.

If you select a language that is different from the OS language, it may not be displayed properly.

2.1 Loading Waveform Data

Procedure

1. Click  or select **File > Open**. The Open File dialog box appears.

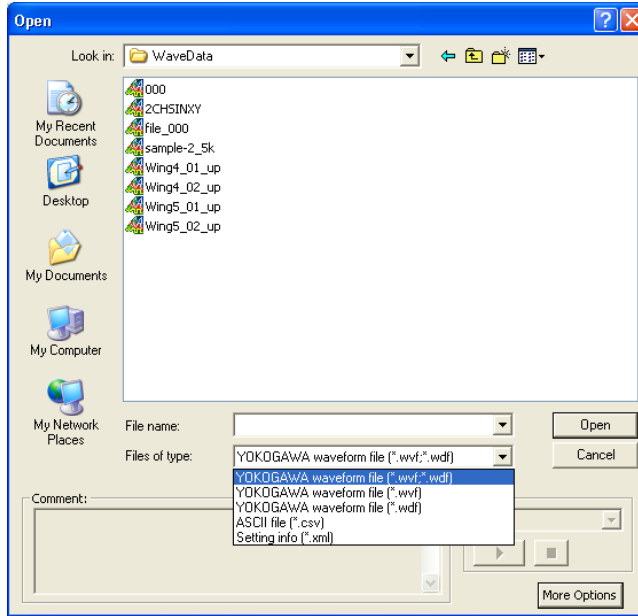

2. To display a waveform, either select the file to open from the File name field, or enter the name of the file and then click **Open**.

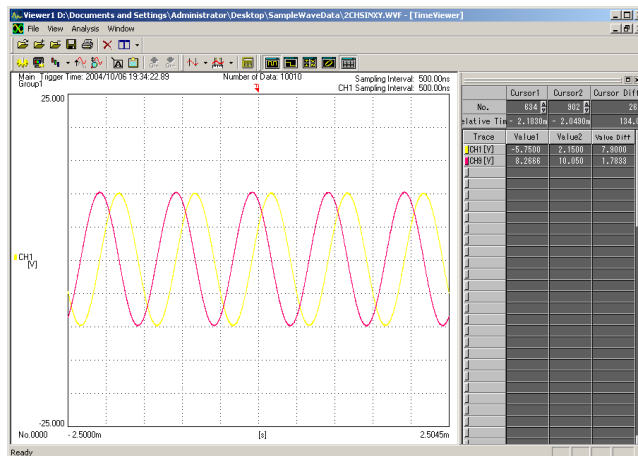

2.1 Loading Waveform Data

When opening a file with comments:

With the DL series, when you open a file that has been saved with comments, those comments appear in the Comment field of the dialog box.

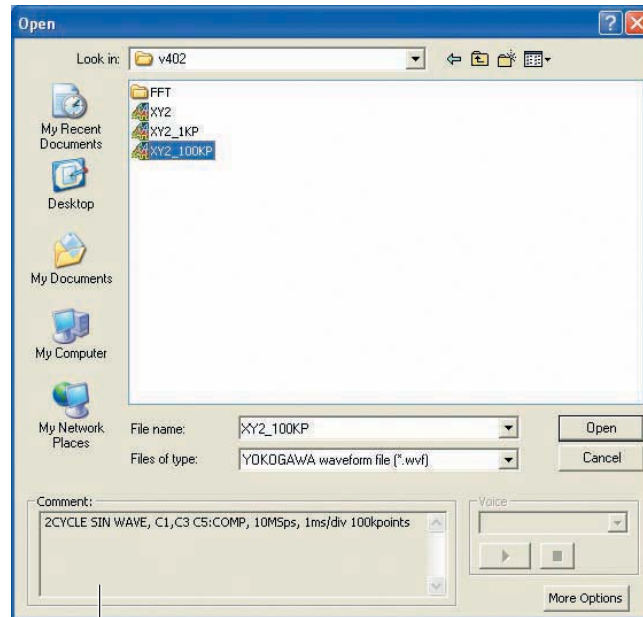

Comments are displayed here

When opening a file with voice memos:

With the DL750 series, when you open a file that has been saved with voice memos, those voice memos can be played back.

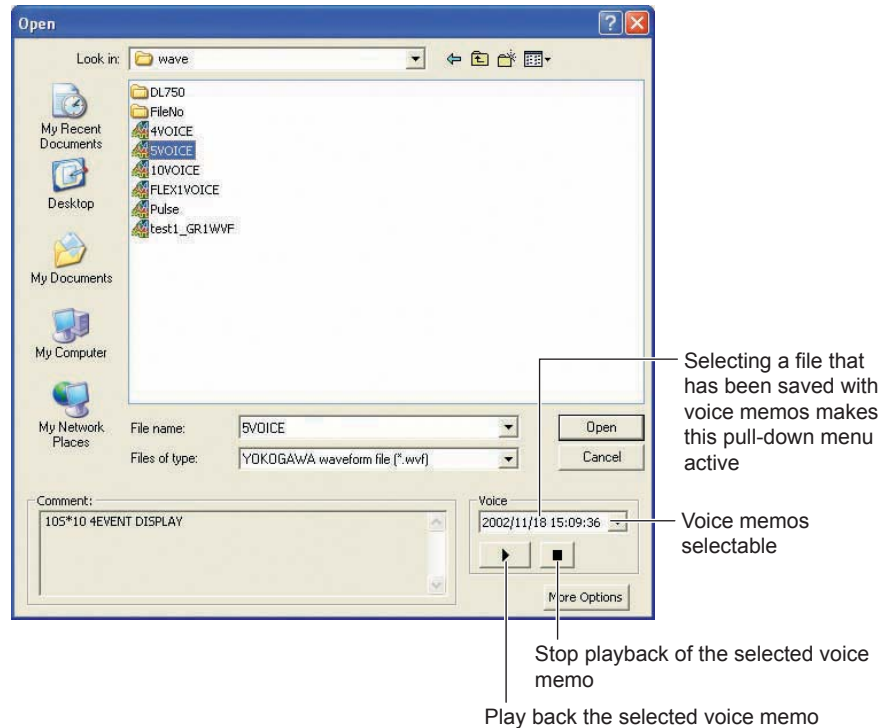

Selecting a file that has been saved with voice memos makes this pull-down menu active

Voice memos selectable

Stop playback of the selected voice memo

Play back the selected voice memo

Note

If your PC does not have audio capabilities, the Play and Stop buttons are grayed out.

Explanation**Types of Files You Can Open with Xviewer**



Model	File Types (filename extension)				
	CSV ¹ (.csv)	WVF ² (.wvf)	WDF ² (.wdf)	WDF ³ (.wdf)	MAT ⁴ (.mat)
WE7000	Yes	Yes	No	No	No
DL1700 series	Yes	Yes	No	No	No
DL1600 series	Yes	Yes	No	No	No
DL1700E series	Yes	Yes	No	No	No
DL7400 series	Yes	Yes	No	No	No
DL750 series	Yes	Yes	No	Yes	No
DL9040/DL9140/DL9240 series	Yes	No	Yes	No	No
DL9500/DL9700 series	Yes	No	Yes	No	No
DL6000/DLM6000 series	Yes	No	Yes	No	No
SB5000 series	Yes	No	Yes	No	No
SL1000	No	No	Yes	Yes	No
SL1400	Yes	Yes	No	Yes	No
DLM2000 series	Yes	No	Yes	No	No
DLM3000 series	Yes	No	Yes	No	No
DLM4000 series	Yes	No	Yes	No	No
DLM5000 series	Yes	No	Yes	No	No
DL850 series	Yes	No	Yes	Yes	Yes
DL350 series	Yes	No	Yes	No	Yes

- 1 Files created and saved in ASCII format
- 2 Files created and saved in binary format
- 3 Files created with real-time recording
- 4 Files saved as MATLAB format

Note

- To open a .wvf file, a header file (.hdr file) having the same name as the file you are trying to open must be placed in the same folder.
- Xviewer cannot simultaneously display waveforms that are captured with different measurement intervals, memory partitions (blocks), trigger points, or other conditions. If you attempt to load a file with waveforms that were measured under different conditions, an error message is displayed and the file is not loaded into Xviewer.
- Xviewer cannot load files with a trace name that includes a space. To load such a file, first replace the spaces in TraceName in the header file (.hdr file) with underscores (_) or other characters.
- Regarding the timestamp (trigger time) displayed in the file open dialog box or on the waveform screen when measured waveform files saved on DLM2000 series instruments of firmware version 1.05 or earlier are opened by Xviewer.
- In the case of waveform data having 1 history waveform, the displayed timestamp is the measurement start time (when the RUN/STOP key on the DLM2000 series main unit is pressed).
- In the case of waveform data having multiple history waveforms, the displayed timestamp differs from the time displayed on the DLM2000 series main unit.

Loading Multiple Files

A new Viewer window can be opened either by clicking  or selecting **Window > Viewer**. Multiple Viewer windows can be open at the same time, allowing you to read and display the contents of multiple files. When multiple Viewer windows are being displayed, you can tile them by clicking  or selecting **Window > Tile**.

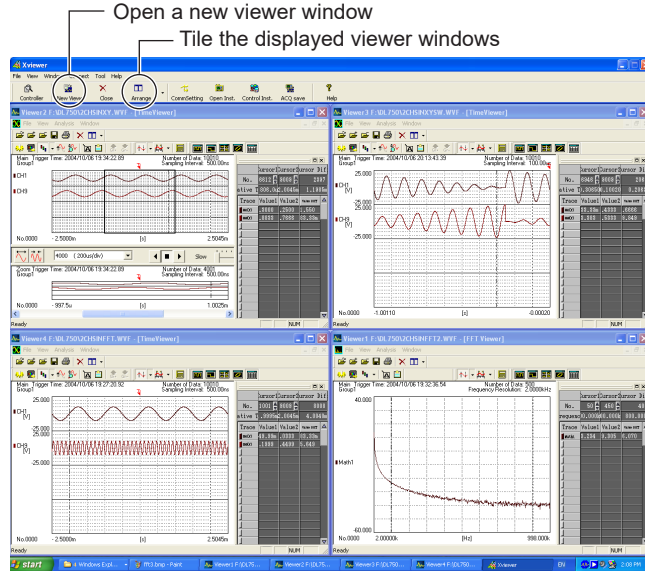

Files that can be dragged

The files with the following extensions can be dragged from the load source window onto the viewer window.

.wvf, .wdf, .csv

Setting Options for Loading Files

Click the **More Options** button to specify supplementary options for loading a file after selecting that file name.

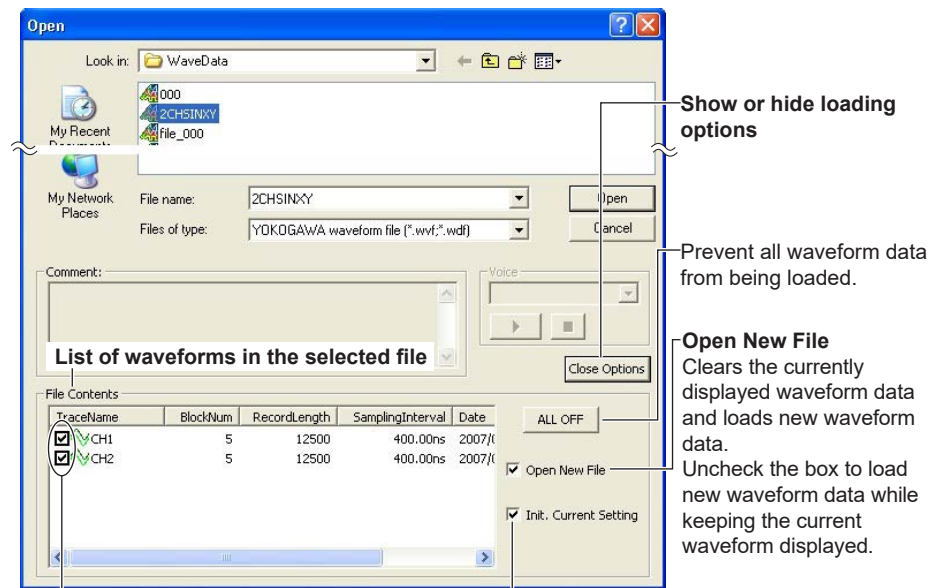

Check the boxes corresponding to the waveform data that you want to load into the viewer

Init. Current Setting
Clears the current display conditions (vertical axis scale, waveform color, screen split, waveform parameters, and computation settings) and loads new waveform data. Uncheck the box to load new waveform data while keeping the current display conditions.

Loading Sequentially Numbered Files

Click either of the buttons shown below to load and display sequentially numbered files in the folder containing the file you are currently viewing, switching the files in ascending or descending order of file numbers.

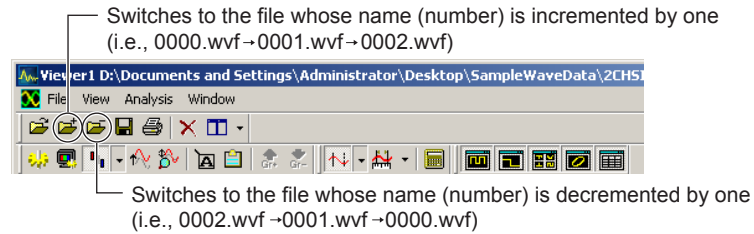

Reference Files in the Instruments

You can directly reference waveform data files saved into the media of the instruments and which are connected to Xviewer. For details, see Section 8.3.

Automatically Loading Display Settings

Waveform data is loaded, the corresponding display settings are automatically loaded. For automatic saving and loading of display settings, see section 5.5.

2.2 Displaying Waveforms in the Main View

Procedure

Displaying Waveforms in the Main View

To display waveforms and measurement results, first open a waveform data file. To show or hide the main waveform display window, click  or select **Window > Main Window**.

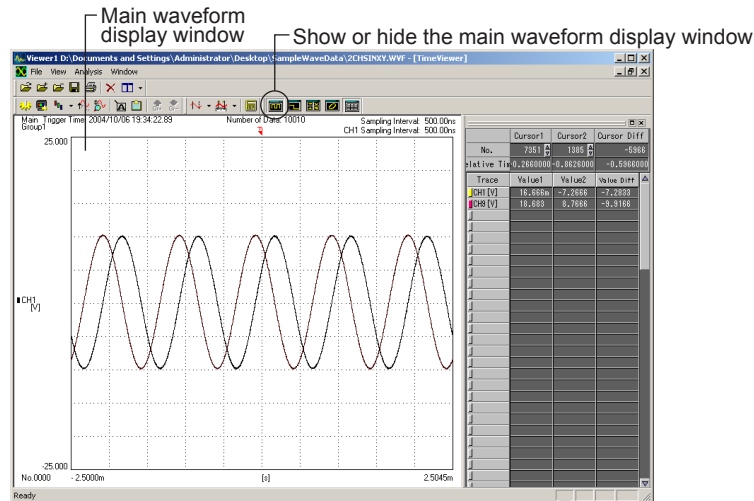

Explanation

Details of the Main Waveform Display Window

The main waveform display window provides a global view of the waveform data.

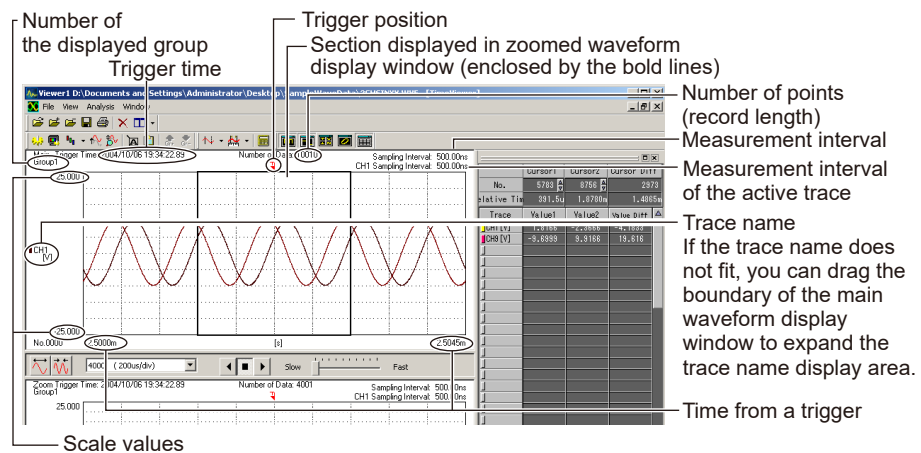

When multiple waveforms are displayed, clicking a waveform or vertical scale (for showing and hiding the vertical scale, see section 3.4) causes the clicked waveform to become active and displayed in front. In addition, the scale values and measurement interval for the active waveform are displayed.

Displaying Tooltips

If you place the pointer on the waveform for about one second, the information for that point is displayed. For example, in the case of a time-voltage waveform, the time and voltage are displayed. The information is displayed for the main and zoomed waveforms. It is not displayed for history, XY, or logic waveforms.

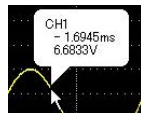



2.3 Displaying Waveforms in a Zoomed View

Procedure

Displaying Waveforms in a Zoomed View

Click  or select **Window > Zoom Window** to display a zoomed view of the section enclosed by the bold lines in the main waveform display window.

Setting the Zoom Factor

To increase or reduce the zoom factor, click  (Zoom-In) or  (Zoom-Out). You can also use the mouse wheel to change the zoom factor.

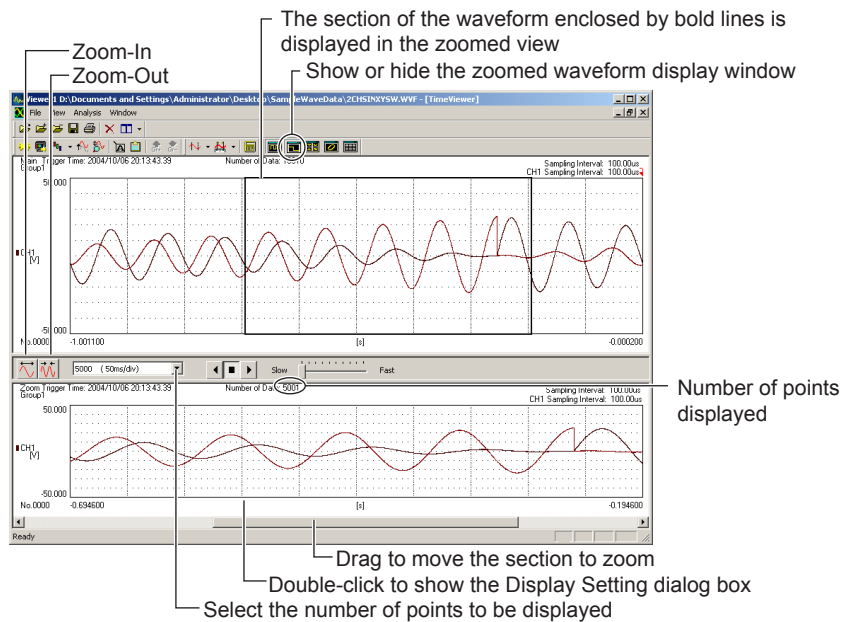

Moving the Zoomed-In Section

You can move the section to zoom by:

- **Dragging the bold line**
You can drag the bold line in the main waveform display window to move the section to zoom. Use the arrow buttons to move it automatically.
- **Designating a point in the Display Setting dialog box**
You can double-click the bottom of the zoomed waveform display window to show the Display Setting dialog box in which you can designate a point at which to start the zoomed section display. Click **OK** to apply the point.
- **Dragging the scroll bar**
You can drag the scroll box at the bottom of the zoomed waveform display window to move the section to zoom.

2.3 Displaying Waveforms in a Zoomed View

Scrolling Zoomed Waveforms

- **Arrow Buttons**
To start scrolling, click ◀ or ▶ to specify the direction you want to scroll in.
- **Stop button**
To stop scrolling, click ■ .
To resume scrolling, click ◀ or ▶ again.

Note

- Waveforms cannot be scrolled during measurement of waveform parameters or computation.
- You can also scroll by using the arrow keys on the keyboard.

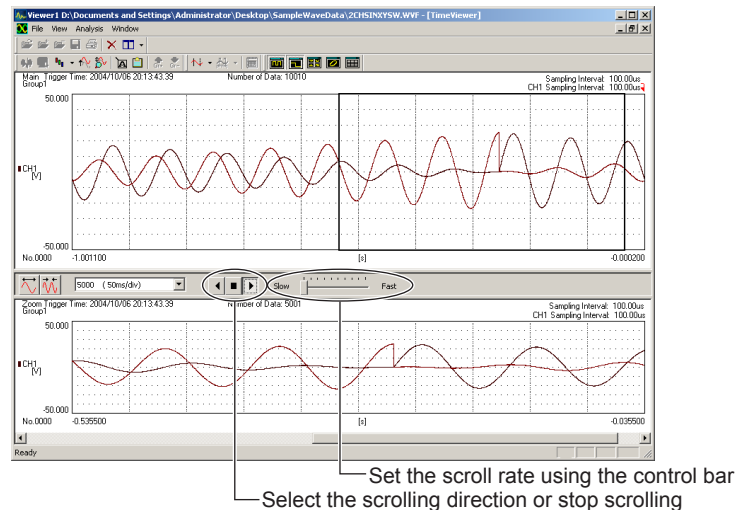

Explanation

Zoom Rate

The maximum zoom rate depends on the data being displayed. A view with 10 or fewer points cannot be zoomed.

Scrolling the Zoomed Waveform View

The zoomed waveform view can be scrolled automatically.

Use the following buttons to select the scrolling direction and rate:

- **Scrolling direction**
 - ▶: Scrolls to the right
 - ◀: Scrolls to the left
 - : Stops scrolling
- **Scrolling rate**
Set one of the ten scrolling rates, from Slow to Fast.

Designating the Section to be Zoomed

To designate the point at which zooming is to start in the Display Setting dialog box, specify the value of the left most point of the zoomed section that you want to view. The values that can be specified vary with the zoom rate and displayed waveforms. •

- Inputting the number of data points: Input an integer to start display from that number of data points.
- Inputting a time: In relative time display mode, input a real number to start display from that time. At this time, m (10^{-3}), μ (10^{-6}), n (10^{-9}), and P (10^{-12}) can be used.
(Example)
 - 1.23 → 1.23 s
 - 1.23 m → 1.23 ms
 - 1.23 E-3 → 1.23 ms
 - 0.00123 → 1.23 ms

2.4 Displaying Waveforms in the History View

Procedure

Displaying Waveforms in the History View

Click  or select **Window > History Window** to open the history waveform display window.

Changing View Sizes

To change the size of the history waveform view, click any of the three Size buttons.

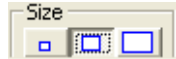

Selecting the History Waveforms to be Displayed

To display all the history waveforms in the main waveform display window, click **ON** for ALL. To display only the active history waveforms in the main waveform display window, click **OFF**.

You can place a checkmark in the check box corresponding to individual history waveform views to select specific history waveform views to be displayed in the main waveform display window.

Making a History Waveform Active

To make a history waveform active in the main waveform display window, click the history waveform view. The history waveform view is enclosed by blue lines and its history waveform number is highlighted.

When other history waveform views are also displayed, the active history waveform view appears brighter than the others.

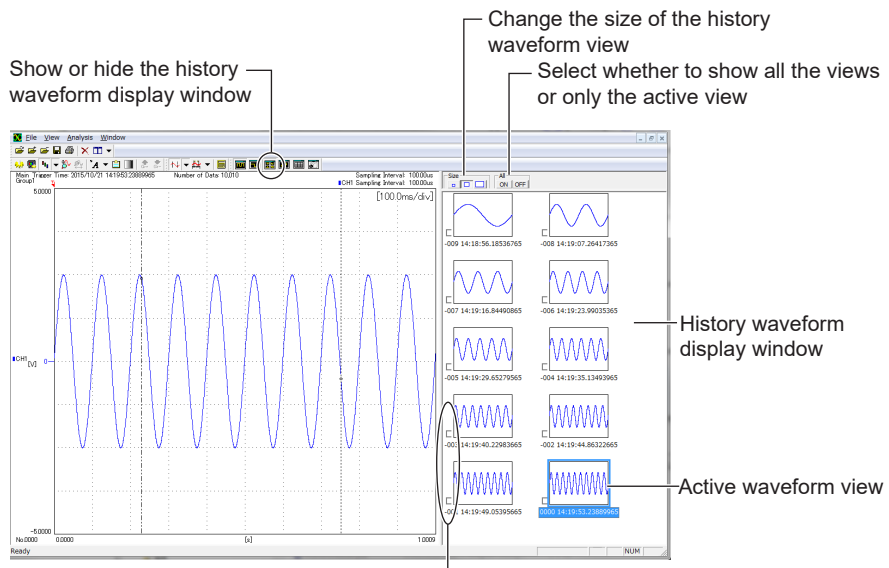

Show or hide the waveform view in the main window

Sample of minimum-size views

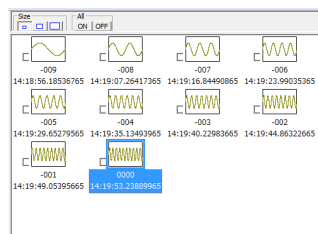

Explanation

Data That Can Be Loaded Using the History Waveform Display Window

The history waveform display window can display waveform records saved with the sequential store, single (N) trigger mode, and/or history waveform handling features of the DL series, SL1400, and SL1000.

Note

An error message will appear if there is insufficient memory.

Sizes of History Waveform Views

You can select one of three sizes for listing the history waveform views.

ALL ON/OFF

You can select whether to display all the history waveform views listed in the history waveform display window in the main waveform display window:

ON: Displays all the history waveform views in the main waveform display window.

OFF: Displays only the active history waveform view.

Active History Waveform View

- Cursor measurements can be applied to active history waveforms.
- The waveforms of the active view appear brighter in the main waveform display window.
- The number of the active view is highlighted in the history waveform display window.

2.5 Displaying a Waveform in the X-Y View

Procedure

Displaying a Waveform in the X-Y View

Click  or select **Window > X-Y Window** to display the X-Y waveform display window.

Selecting a Waveform to be Displayed in the X-Y view

To see a waveform displayed in the main waveform display window in the X-Y view, click **Main** under Range.

To see a waveform displayed in the zoomed waveform display window in the X-Y view, click **Zoom** under Range.

Setting the X-Axis

Select a waveform (trace name) to be assigned to the X-axis by using the X-Trace list box.

All waveforms other than that assigned to the X-axis are allocated to the Y-axis.

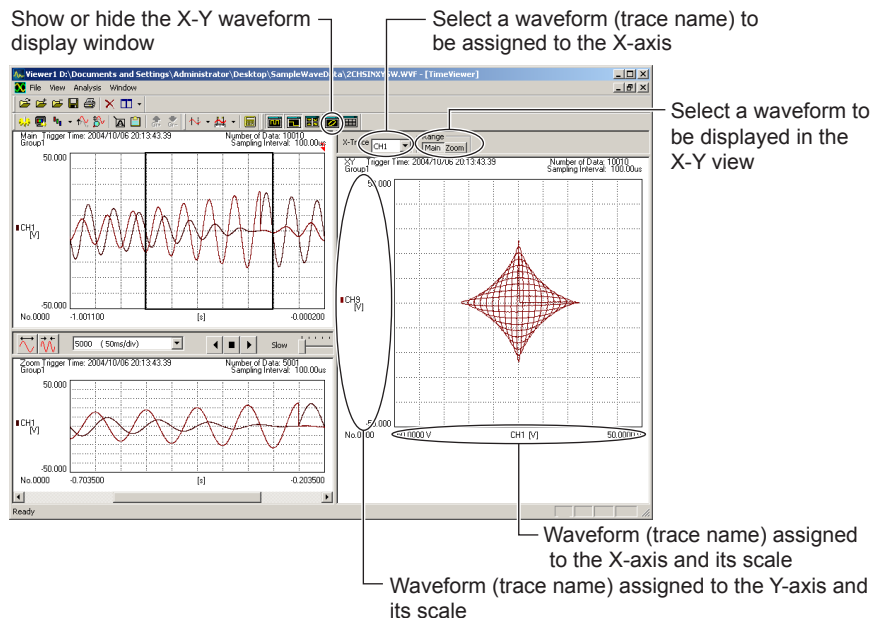

2.5 Displaying a Waveform in the X-Y View

Overlaying X-Y Waveforms

The active waveform in the history waveform window can be overlaid on the X-Y waveform display window. If Range is set to Main, the waveform in the main waveform display window is overlaid. If Range is set to Zoom, the waveform in the zoom waveform display window is overlaid.

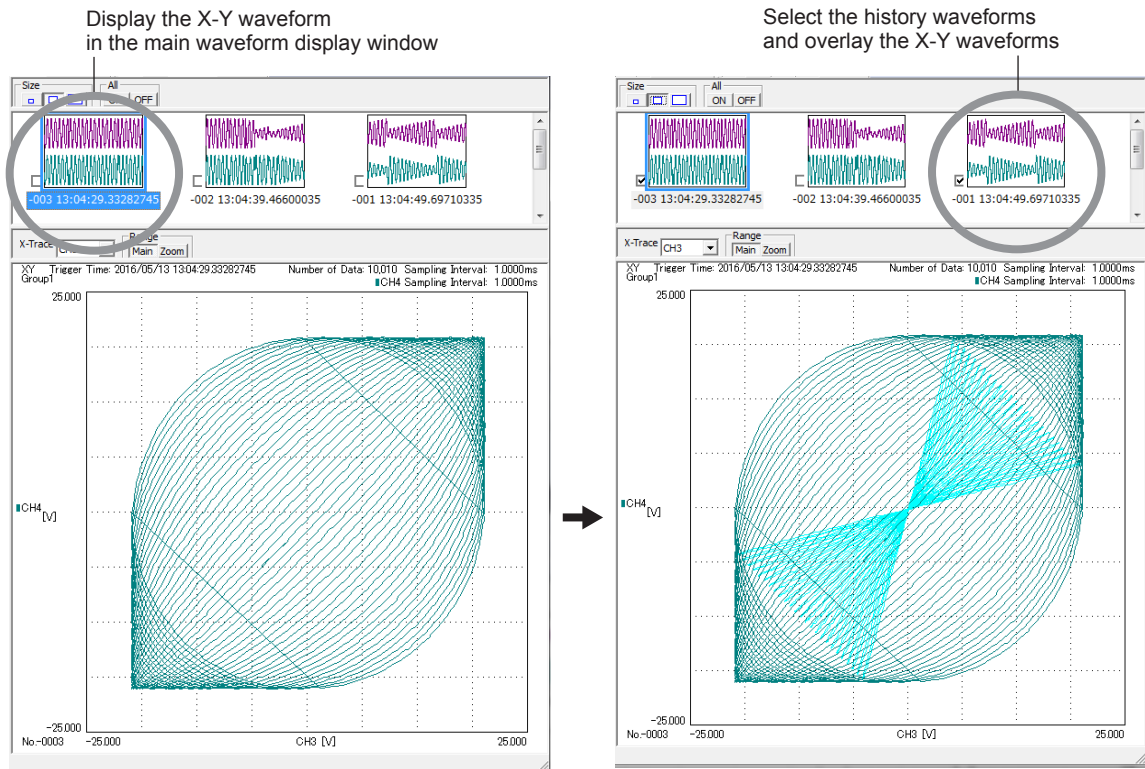

Note

- The X-Y waveform display window plots P-P data displayed in the main, zoom, or history waveform display window into the X-Y view.
- The X-Y view of logic waveforms cannot be shown.

2.6 Moving or Zooming Waveforms

Procedure

Moving or Zooming (Expanding/Reducing) the Waveforms Vertically

1. Click  or select **View > Waveform Vertical Zoom&Move**.
2. Using the mouse, drag the waveform you want to move.
3. Click the waveform you want to expand. The selected waveform expands around the clicked point. Right-click the waveform to reduce the waveform around that point.

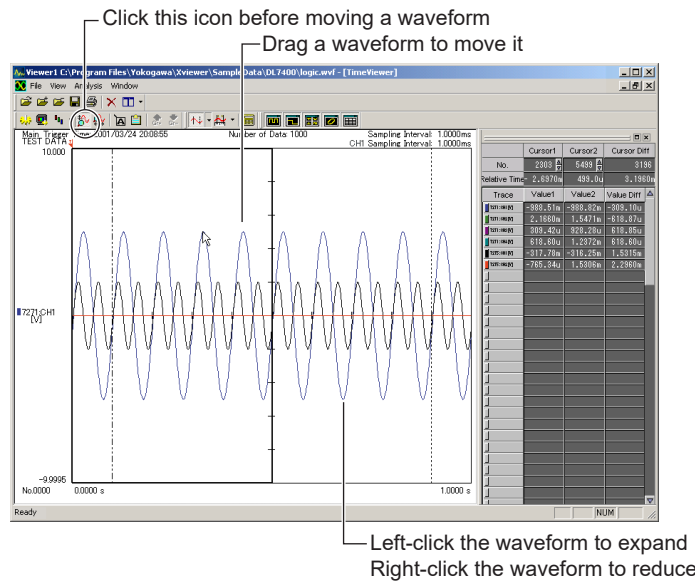

Moving or Zooming (Expanding/Reducing) the Waveforms Horizontally

1. Click  or select **View > Waveform Horizontal Zoom&Move**.
2. Drag the frame or a point in the frame in the main waveform display window or the zoom waveform display window.
3. Click on the main or zoom waveform display window to expand the zoom display waveform around the clicked point. Right-click the waveform to reduce the waveform around that point.

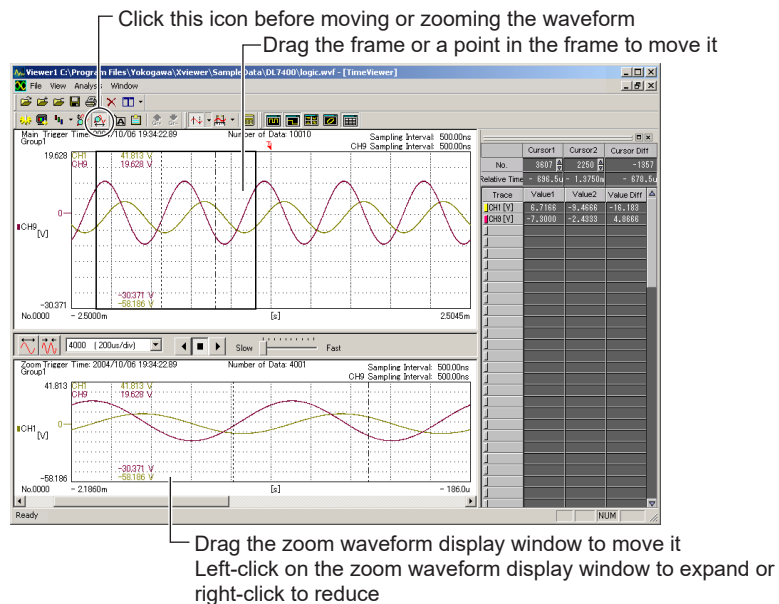

2.6 Moving or Zooming Waveforms

Note



or **View > Waveform Horizontal Zoom&Move** is selectable only if the zoom waveform display window is displayed. For the procedure to display the window, see section 2.3.

Explanation

Applicable Windows

Move and zoom can be applied to the main or zoom waveform display window.

2.7 Splitting the Screen

Procedure

Splitting Waveforms by a Trace

Click  or select **View > Split** to overlap the waveforms in the main waveform display window or zoomed waveform display window, splitting them based on the trace name.

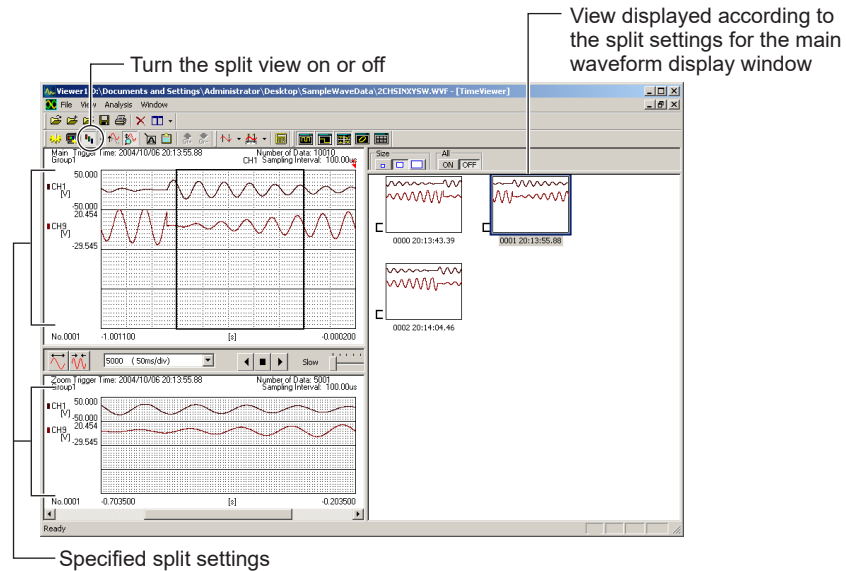

Explanation

Split Settings

The default value for the number of split waveforms depends on the number of waveforms that are automatically identified by Xviewer, and is used both for the main waveform display window and zoomed waveform display window. The default value can be changed using the split setting dialog box. Using this dialog box, you can specify different split settings for the main waveform display window and zoomed waveform display window or modify the default split settings. For details, see Section 3.3.

2.8 Displaying Waveforms Acquired with the DL850 series Dual Capture Function

You can display the main and capture waveforms acquired with the DL850 series Dual Capture function.

Procedure

Load data captured with the DL850 series Dual Capture function according to the instructions in section 2.1, “Loading Waveform Data.” The main waveform is displayed. A triangle is displayed at the position of the capture waveform.

A triangle appears at the position of the capture waveform

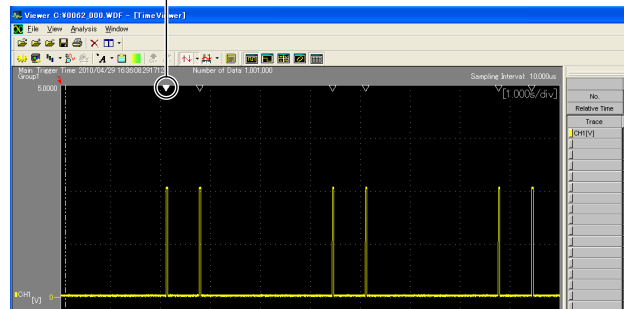

Capture Waveform Display

1. Double-click the capture waveform mark, or click **View > DualCapture List**. The dual capture list is displayed.
2. Double-click the capture waveform to display, or select it and click **Capture**. The selected capture waveform is displayed.

Select the capture waveform to display

Capture No.	Points	Relative Time
0	211637	2010/04/29 16:36:10.404760
1	277998	2010/04/29 16:36:11.071698
2	544640	2010/04/29 16:36:13.738112
3	611330	2010/04/29 16:36:14.405021
4	877972	2010/04/29 16:36:17.071434
5	944663	2010/04/29 16:36:17.738343

Click to display the selected capture waveform

Capture waveform

Appears when displaying a capture waveform

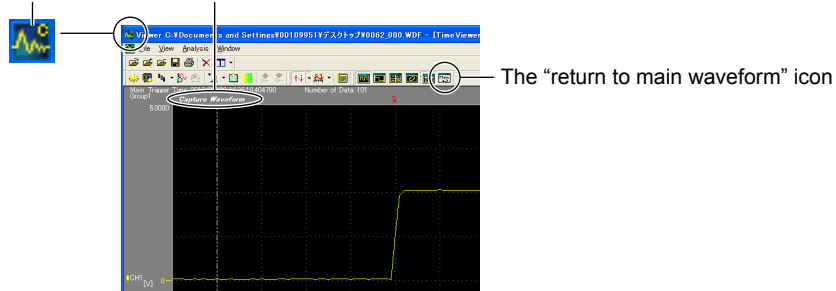

Returning to the Main Waveform

1. Click the “return to main waveform” icon, or click **View > Return to main waveform**. The main waveform is displayed.



Explanation

You can link, analyze, and display the main and capture waveforms acquired with the Dual Capture function.

2.9 Switching between Groups

Procedure

Switching between Groups

When you have already registered groups, you can switch between those groups either by clicking , or  by selecting **View > Next Group/Previous Group**.

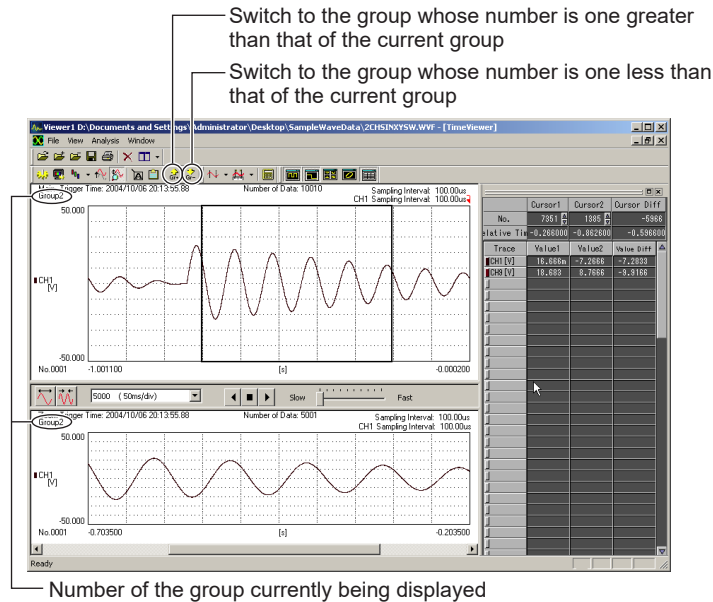

Auto Group Setting

Click **View > Auto Group Setting** to open the screen below. Enter the number of channels in a group.



Explanation

Grouping Channels

In the Channel Setting dialog box, you can group channels by trace name. In addition, the specified number of channels can be automatically allocated to a single group. For details, see Section 3.2.

Note

If there are no groups,  and  are unavailable (no operation even if they are clicked).

Set Auto Group

Enter a value in the **Number of Channels in Group** box and click **OK** to automatically assign the specified number of channels to a single group. For example, if you enter 30, channels are assigned as follows: CH1 to CH30 to group1, CH31 to CH60 to group 2, and so on. If you select the **Initialize Channel Setting** check box and click **OK**, channel settings such as the ON/OFF condition of the display, scale, and waveform color are initialized.

2.10 Showing Marks

Procedure

Showing Marks

Click **View > Show Marks**. The marks are displayed.

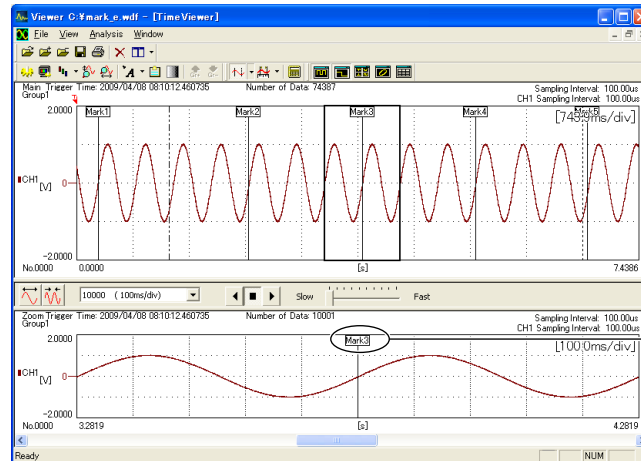

Mark List and Jump

Click **View > Mark list**. The screen below appears. Select a jump destination, then click **Jump**. The selected mark is displayed in the center of the zoom waveform window.

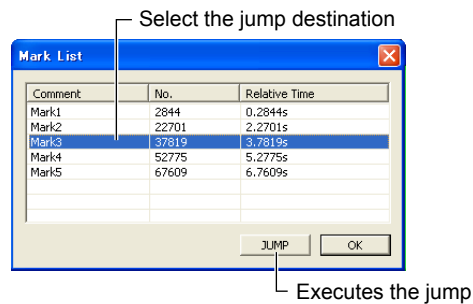

Explanation

Showing Marks

Marks are displayed when loading waveform data from mark files (extension: .mrk). Also, you can display previously set marks in a list, and jump to any mark you specify. This function is available with waveform data on which marks have been set using version 2.10 or later of the SL1000 acquisition software.

2.11 Displaying Waveform Properties

Displaying Waveform Properties

Click **View > Waveform Property**. The waveform properties are displayed.

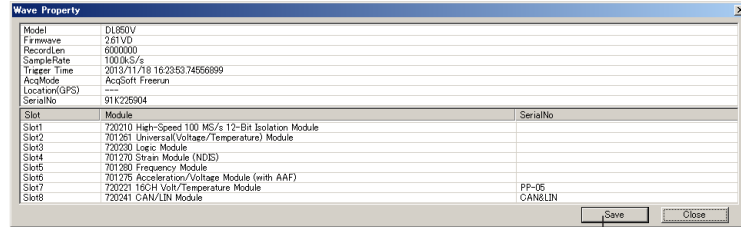

Save the waveform properties

Saving Waveform Properties

Click **Save** to save the contents shown on the waveform properties screen to a text file.

3.1 Loading Display Settings

The display conditions specified on the current viewer window can be saved in XML format. You can also include comments when saving the file. If you load the display conditions that you created, the conditions are applied to the current viewer window. For the procedure to create and save the display conditions, see section 5.5.

Procedure

Loading Display Settings

Click  or select **File > Open** to display the Open File dialog box. Select **Setting info (*.xml)** in Files of type, browse to the folder containing your target file, select the name of the file you want to open, and then click **Open**. The display settings are loaded from the file into the viewer window.

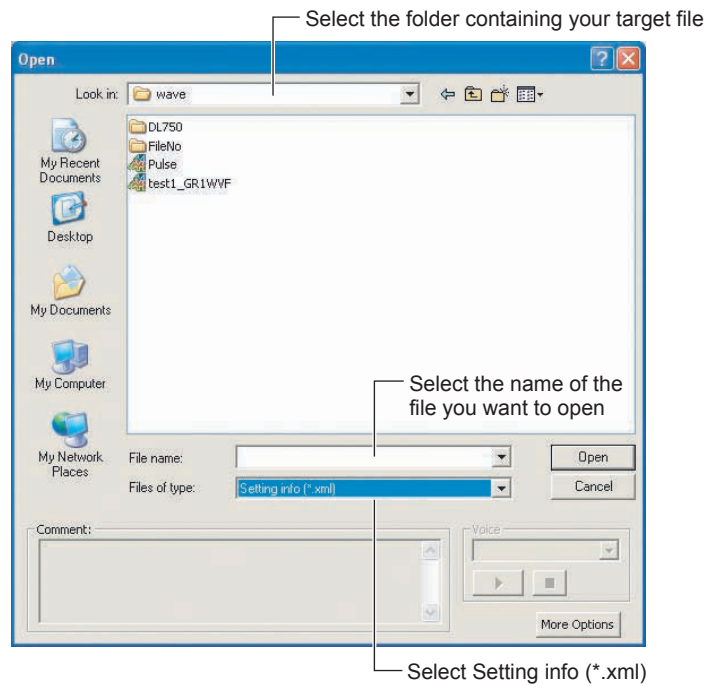

Explanation

Application of Display Settings

Loading a Display Setting file already saved applies the display settings in the file to waveform views.

3.2 Setting Waveforms (Channels) to be Displayed

Procedure

Displaying the Channel Setting Dialog Box

Click  or select **View > Channel Setting** to display the Channel Setting dialog box. Using this dialog box, you can specify the display and group settings for the respective channels.

Grouping Channels

You can group the channels (trace names) to be registered. You can handle waveform display settings in units of groups.

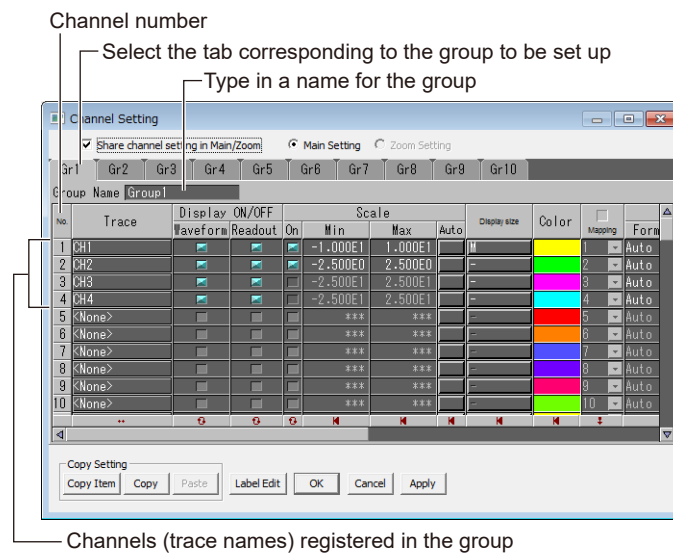

Setting Up Channels (Traces)

Set up the channels (traces) for each channel number. Click a trace name to display the Channel dialog box, and then select a channel (trace name) from the dialog box. Pointing the cursor to a trace shows the detailed information of the selected channel (Sampling Interval, Sampling Rate, Record Length, Module). (Module appears only in WDF files saved with the DL850E/DL850EV/DL350.)

Specifying whether to Show or Hide Waveforms and Cursor Measurement Values

Specify whether to show or hide the waveform and cursor measurement values for each channel number.

Setting Scales

Set the scale values for each channel number.

Setting the Display Size

This setting is valid when split view is enabled. For details, see section 3.3.

Setting Waveform Colors

Using the color palette, set the waveform colors for each channel number.

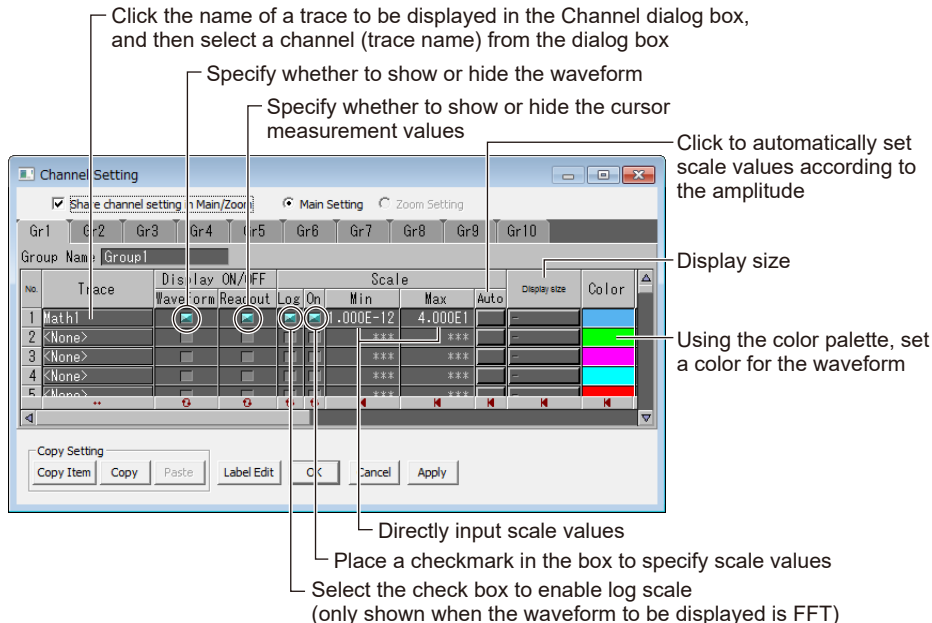

Specifying Waveform Mapping Manually

Click **More Options** to expand the dialog box.

For each channel, you can manually specify in which screen (when the viewer window is split) to display waveforms using mapping numbers 1 to 32. Select the Mapping check box, and then select the mapping number from the drop-down menu.

If you clear the Mapping check box, the manual mappings are not applied.

For example, if there are 4 splits and the mapping number is 10, the waveform is displayed in the second screen from the top. When 10 is divided by 4, the remainder is 2. This “2” indicates the second split screen. If the remainder is 0, the waveform is displayed in the bottom-most screen.

Setting the Display Format, Distal Line, Mesial Line, Proximal Line, and High and Low Values

For each channel number, you can set (1) the display format and the number of displayed digits of the values on the viewer window, (2) logic waveform display conditions, and (3) the distal line, mesial line, proximal line, and high and low values used in waveform parameter computation.

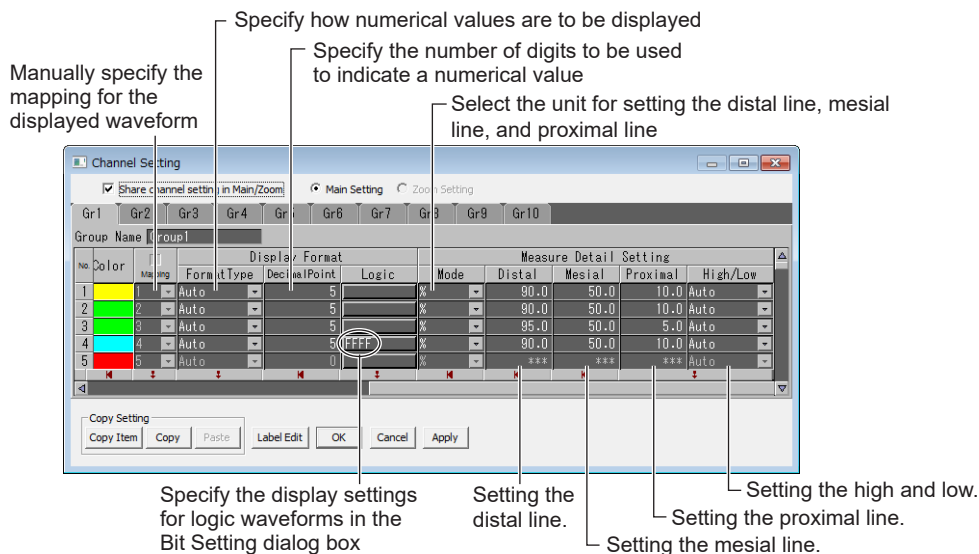

3.2 Setting Waveforms (Channels) to be Displayed

Editing Labels

Displaying the Edit Label Dialog Box

In channel settings, click **Label Edit** to display an Edit Label dialog box. Edit the labels of each channel.

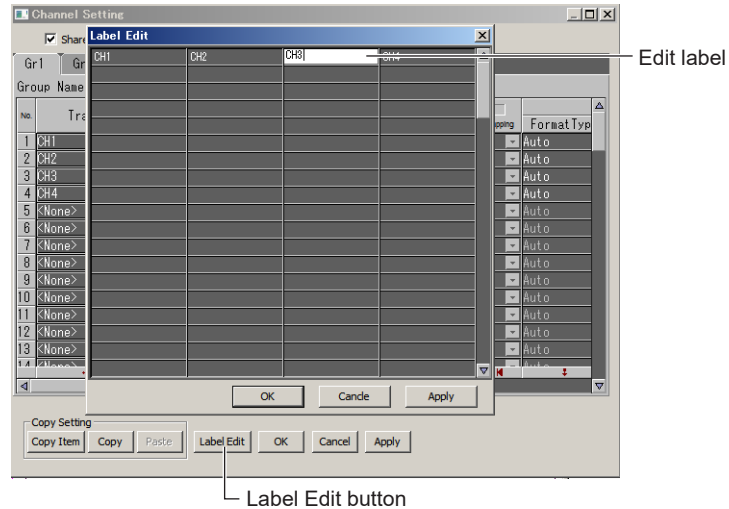

Editing Labels

Click the label to edit.

Note

For WDF, WVf, and CSV files saved with the DL850E/DL850EV, clicking OK or Apply updates the labels of the waveform file and overwrites the file.

Explanation

Channel (Trace Name) Settings Shared

Channel (trace name) settings are shared by the main waveform display window and the zoomed waveform display window. The cursor measurement value is used as the main waveform display setting.

To apply different channel settings to each of the windows, remove the check mark from **Apply Channel Settings in both Main/Zoom**, place a check mark in **Main Window** or **Zoom Window**, and then make the individual channel (trace name) settings.

Number of Groups and Number of Channels (Traces) that Can Be Registered

Xviewer lets you create up to 10 channel (trace name) groups. You can register up to 90 channels per group.

Setting Items to Copy and Paste

Xviewer lets you copy the settings for a channel (trace) selectively and then paste those settings to another channel. After pressing **Copy Item** to display the Select Copied Items dialog box, you can define the setting items that you want to copy in advance. The Select Copied Items dialog box is also displayed when you execute a paste command, allowing you to remove any unnecessary setting items and paste only those which are required.

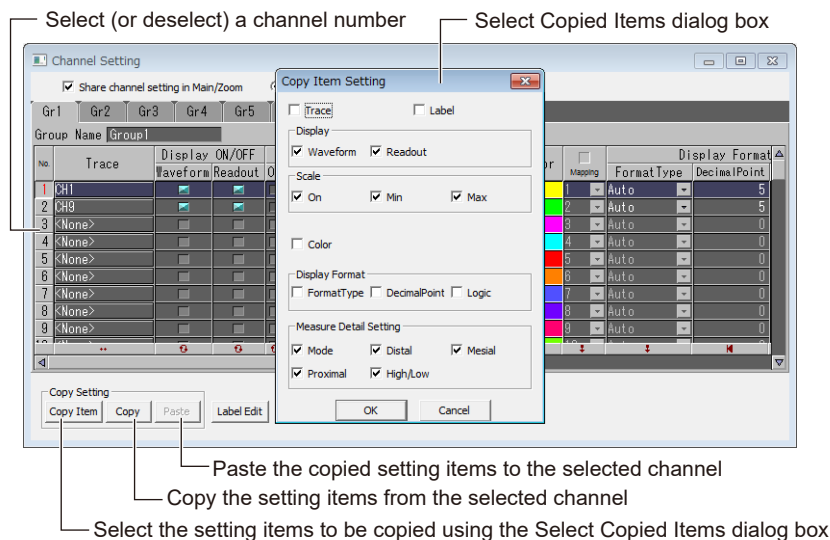

Changing All Settings Together

The Channel Setting dialog box provides buttons that allow you to select and change all the settings together.

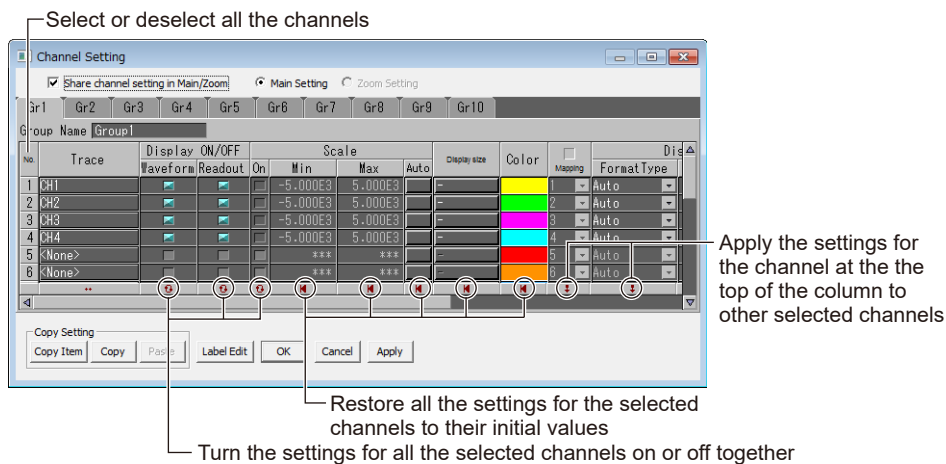

3.2 Setting Waveforms (Channels) to be Displayed

Notational Format Items

You can specify the following notational format items:

- **Format Type:** Select **Auto Floating Point** or **Exponential**
Selecting either **Floating Point** or **Exponential** causes the following data to be displayed in the viewer windows, using the selected type of notation:
Scale Values, Values of Cursor Measurement, and Waveform Parameters (Amplitude Maximum, Minimum, High Level, Low Level, Peak to peak value, Average, Middle, RMS, Int1TY, and Int2TY)
- **Decimal Point:** Specify the number of decimal places to be displayed for both the floating point and exponential notations.
- **Logic:** Specify the display settings for the logic waveforms in the Bit Setting dialog box. Specify to display up to 32 bits for the DL9700 series, SB5000 series, DL6000/DLM6000 series, and DLM5000 series, up to 16 bits for the DL9500, DL750, and SL1400 series, and up to 8 bits for the DL7400 series, DLM2000 series, DLM3000 series, DLM4000 series, DL850 series, and DL350 series.

The screenshot shows the 'Bit Setting - Group1' dialog box. It features a table of bit settings and several control panels on the right. Callouts point to the following elements:

- Bit Name:** Display the bit name. Displayed when bit names are specified in the loaded logic waveform.
- On (checkbox):** Place a checkmark against those bits that are to be indicated.
- Mapping:** Select whether to display those waveforms that align only with turned-on bits at regular intervals (waveform view changed), or those waveforms that align with all the bits (waveform view unchanged) if any bits are turned off in the dialog box.
- Location:**
 - 1/1:** Display the logic waveforms using the entire window.
 - 1/2Up:** Display logic waveforms in the upper half of the window.
 - 1/2Low:** Display logic waveforms in the lower half of the window.
- Bit Display Order:** Set the order in which the bits are displayed:
 - MSB:** Displays the bits from the most significant bit.
 - LSB:** Displays the bits from the least significant bit.
- Measure result:** Display format of the values displayed in the measurement result display window.
 - Binary:** Displays values in binary.
 - Hex:** Displays values in hexadecimal.
- ActiveLevel:** Set the highlight display of logic waveforms.
 - High:** Highlight the high level.
 - Low:** Highlight the low level.
- Bundle:** Display the logic waveforms in bus format.

Cursor Data Display Method (Measure Result)

The measured values can be displayed in binary or hexadecimal notation.

Binary: Displays values in binary notation.

Hex: Displays values in hexadecimal notation.

Bundle ON/OFF Setting (Bundle)

If you set Bundle to ON, the data of each logic probe (PodA, PodB, PodC, and PodD) can be combined together into up to 32-bit data and processed. If an OFF bit is present, the bit is displayed as a hyphen in binary display. The bit is considered to be not present in hexadecimal display.

Cursor Data Order (Bit Display Order)

You can select the order of the bits of the logic probe. Select MSB to select bit 7 to bit 0 order; select LSB to select bit 0 to bit 7 order. In addition, the displayed order and number vary depending on the model as follows:

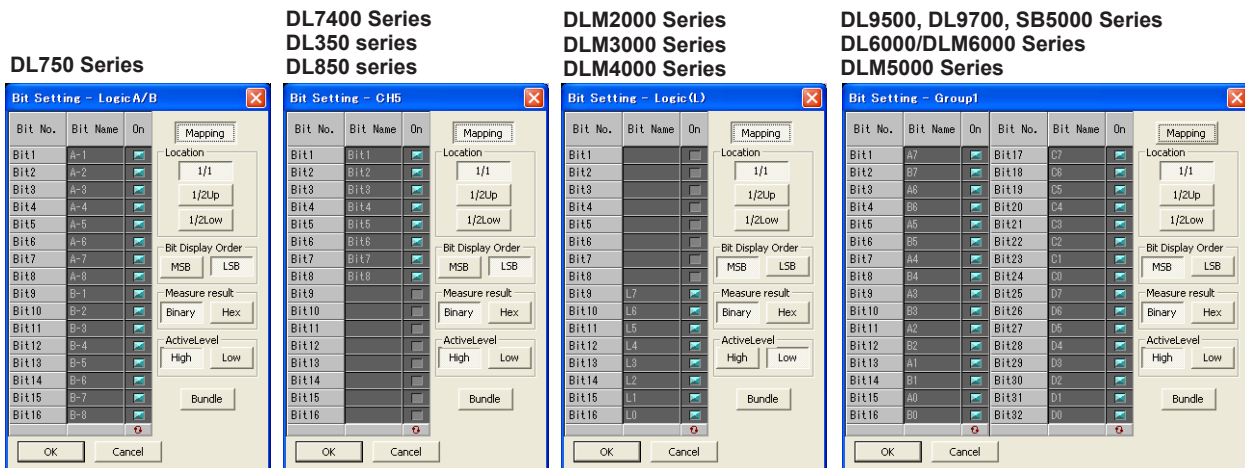

Cursor Measurement Example (for V Cursor)

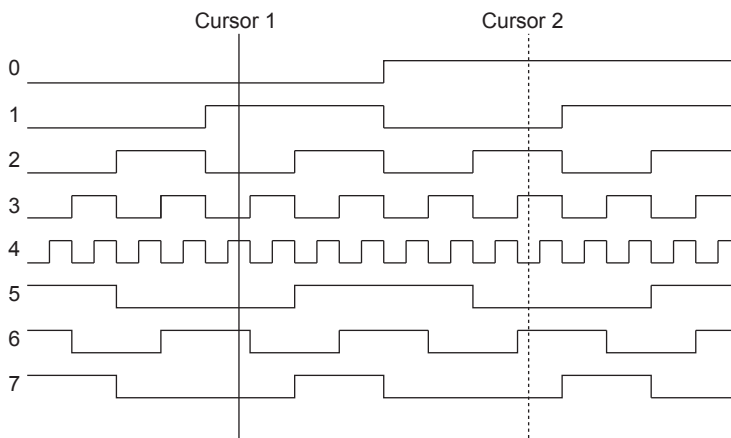

For the case above, if the data bit order is A0 to A7 B0 to B7

Binary Y1: 01001010 Y2: 10110010

Hexa Y1: 4A Y2: B2

If B7 to B0 A7 to A0

Binary Y1: 01010010 Y2: 01001101

Hexa Y1: 52 Y2: 4D

3.2 Setting Waveforms (Channels) to be Displayed

If OFF bits are present, the data is displayed as follows:

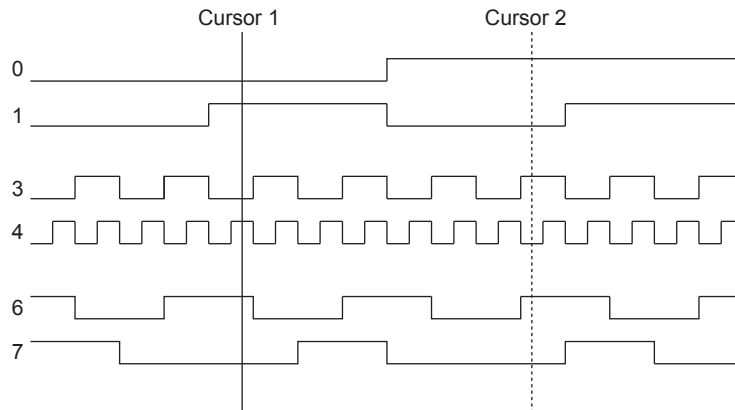

If A0 to A7 B0 to B7

Binary Y1: 01*01*10 Y2: 10*10*10

Hexa Y1: 16 Y2: 2A

If B7 to B0 A7 to A0

Binary Y1: 01*10*10 Y2: 01*01*01

Hexa Y1: 1A Y2: 15

Note

If Bundle is set to ON, the individual bit displays cannot be turned OFF.

- When a waveform that has been saved in roll mode without any waveform data is displayed, logic waveforms are displayed as all zeros.
- When a waveform that has been saved on the DLM4000 with STATE set to ON and with state source bits selected is displayed in Xviewer, all bits are displayed as state source bits.
- The waveforms of logic A and B (8 bits each) of the DL750 are displayed as a single logic waveform (16 bits) in Xviewer.
- On the DLM5000, if A0 and B0 are assigned to State, Xviewer displays only the B7-B0 and A7-A0 state waveforms (not C7-C0 or D7-D0).

Apply Button for Confirmation

Clicking **Apply** after you have changed the settings applies the previously specified settings to the window(s) while keeping the display setting screen displayed.

Note

If you double-click the scale display area of the vertical axis, a channel setting window (simplified version) appears as shown below.

On this window, you can turn OFF the display or set the scale for channels that have been turned ON in advance on the channel setting window of page 3-2.

When the displayed waveform is FFT

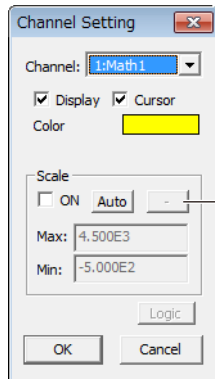

When the displayed waveform is not FFT

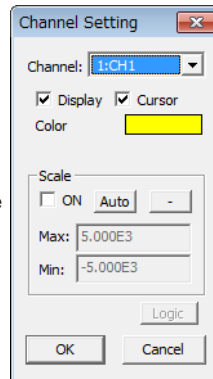

When the displayed waveform is logic

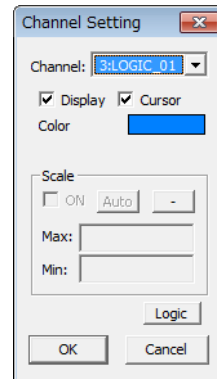

3.3 Specifying Split Settings

Procedure

Displaying the Split Settings Dialog box

Click ▼ beside  or select **View > Split Setting** to display the Split Setting dialog box.

Specifying Split Settings

In the Split Setting dialog box, specify whether to allow the main waveform display window and zoomed waveform display window to share the split settings and the number of waveform splits in the respective windows, and then click **OK**. The split settings that you have specified are applied to the window(s).

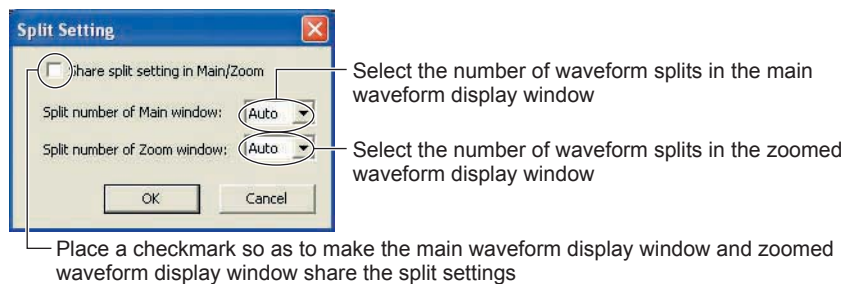

Waveform Display Size

You can expand the vertical display span of a waveform by double-clicking the waveform displayed in a split window.

M: Displayed in an area that is 20% of the entire vertical axis

L: Displayed in an area that is 40% of the entire vertical axis

–: Equally divided

Explanation

Number of Waveform Splits that Can Be Specified

For each of the main waveform display window and the zoomed waveform display window, you can specify Auto or any value between 1 and 32. Auto sets the number of waveform splits according to the number of waveforms to be displayed.

Waveform Mapping

When the screen is split, waveforms are mapped in order of channel number, starting from the top-most split screen. You can also specify arbitrary waveform mappings. For instructions on specifying arbitrary mappings, see section 3.2.

Split Settings for the History Waveform Display Window

Split settings made for the main waveform display window are also applied to the history waveform display window.

Waveform Display Size

The display area of up to two waveforms can be expanded vertically. If more than two waveforms are being controlled, the waveform that is being controlled and the waveform displayed above it take precedence.

You can also set this on the channel setting window.

3.4 Specifying Display Settings

Procedure

Displaying the Display Setting dialog box

Click  or select **View > Display Setting** to open the Display Setting dialog box. Click the Graticule, Horizontal Axis, Color, Size, and Other information tabs, and configure the display settings.

Making a Graticule Setting

Click the **Graticule** tab in the Display Setting dialog box. The Graticule pane appears. Using this pane, you can specify the graticule type and the units of the divisions on the vertical axis.

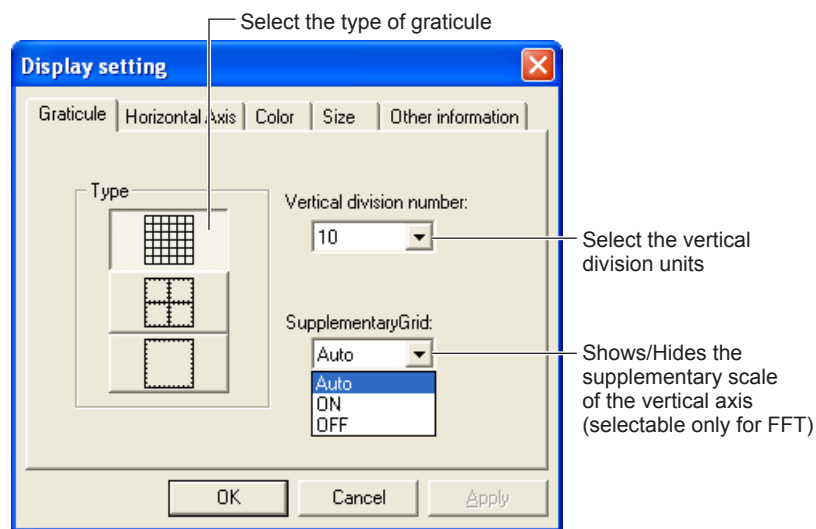

Setting the Horizontal Axis

Click the **Horizontal Axis** tab in the Display Setting dialog box to display the Horizontal Axis pane. Using this pane, you can specify the point at which to start displaying the zoomed section, as well as the notational format for the horizontal axis.

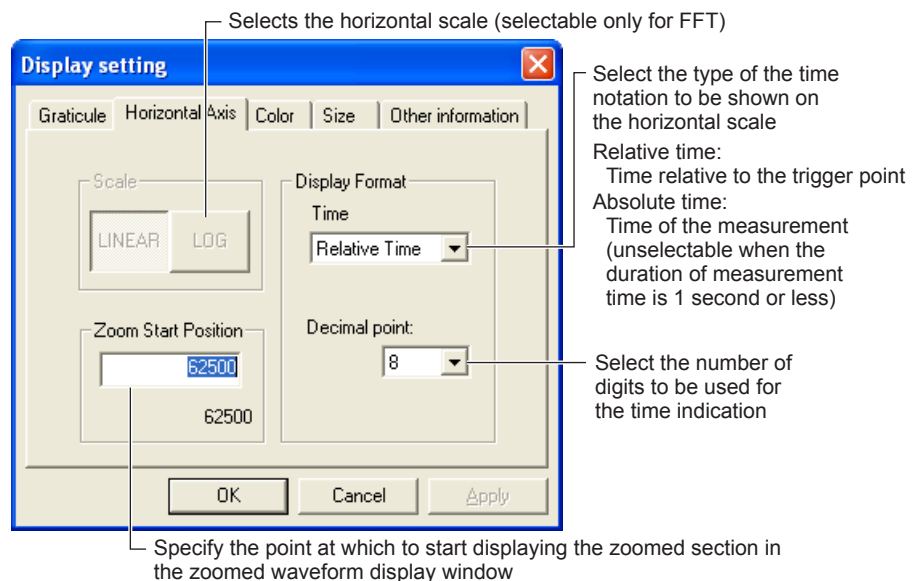

Setting the Colors

Click the **Colors** tab in the Display Setting dialog box to display the Colors pane. In this pane, you can specify the colors for the background, graticule, and text using the color palette.

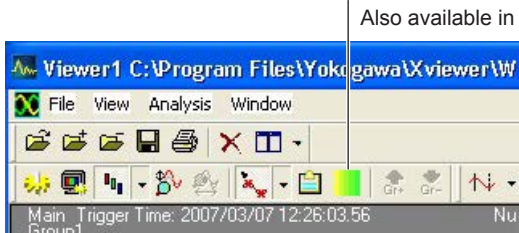
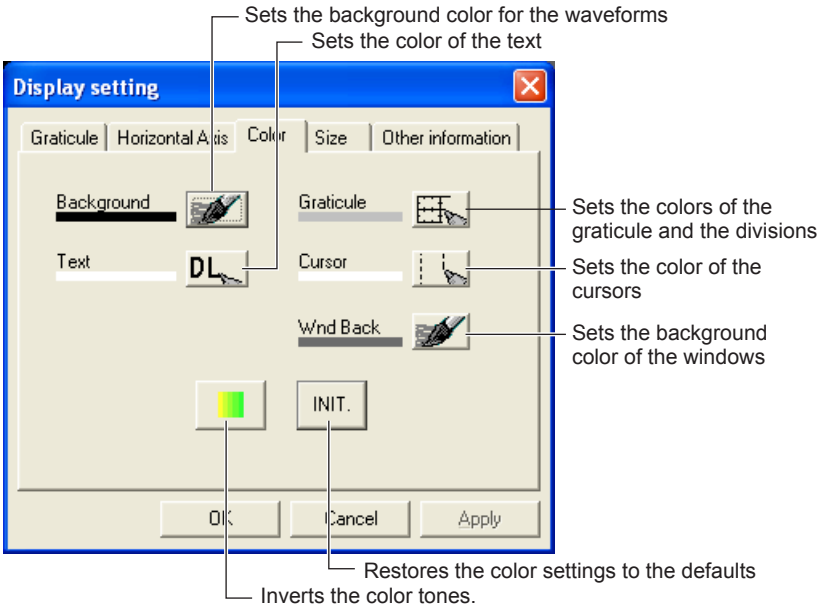

Setting the Waveform Thickness and Grid Line Thickness

Click the **Size** tab in the Display setting dialog box to display the Pane for setting the waveform thickness and grid line thickness.

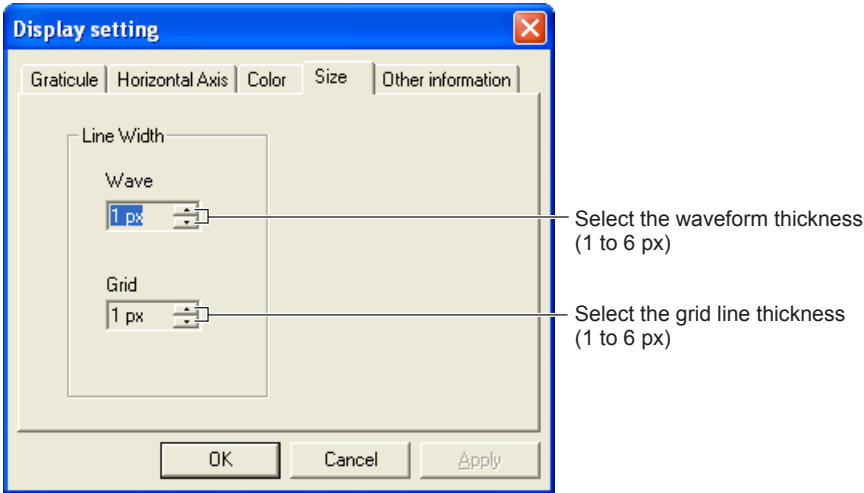

3.4 Specifying Display Settings

Displaying Scale Information in the Waveform Display Window

Click the **Other information** tab in the Display setting dialog box to display a panel for setting the T/div, V/div, 0 Level, Bit Label, and multiple vertical scale display settings. Select the check boxes of the desired items to display the corresponding information in the waveform display window.

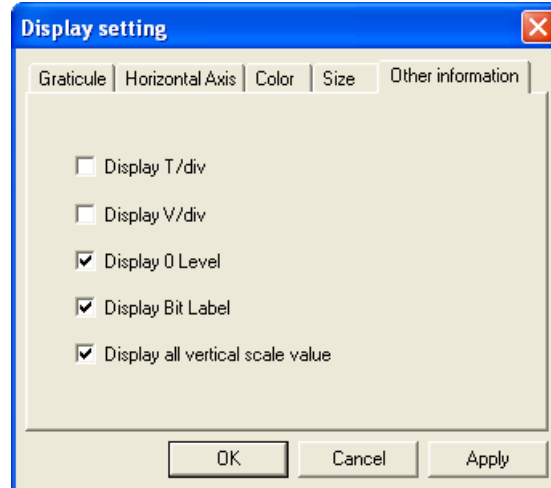

Note

You can also double-click the scale display area of the horizontal axis to open the Display Setting dialog box.

Explanation

Setting the Grid

- Supplementary Grid
The supplementary grid can be selected only when the FFT computation waveform is displayed.
Auto: Automatically determines whether to display the supplementary scale on the vertical axis.
ON: Displays the supplementary scale on the vertical axis.
OFF: Does not display the supplementary scale on the vertical axis.

Setting the Horizontal Axis

- Display Format
Sets the time type (relative or absolute) and the number of displayed digits. However, the Display Format settings do not appear when the FFT computation waveform is displayed.
- Zoom Start Position
When relative times are being displayed, the settings vary depending on whether an integer or a real number is input.
Integer input: Start data position
Real number input: Start time (auxiliary units m, n, u, and P can be input.)
- Scale
Set the horizontal scale to LINEAR or LOG. The horizontal scale can be selected only when the FFT computation waveform is displayed.

Setting the Color

You cannot change the waveform colors in the Display Setting dialog box. To change colors of the waveforms, use the Channel Setting dialog box. For details, see Section 3.2.

- Changing the color tone
Clicking the Color Set button makes the appropriate color settings for monochrome printing. To restore the color settings, click the Color Set button again.
- INIT.
Initializes the color settings to the default condition.

T/div, V/div, and 0 Level Display

You can display T/div, V/div, and 0 Level in the waveform display window. The values of the selected items are displayed. If multiple waveforms are displayed in the waveform display window, the V/div and 0 Level of the active waveform are displayed.

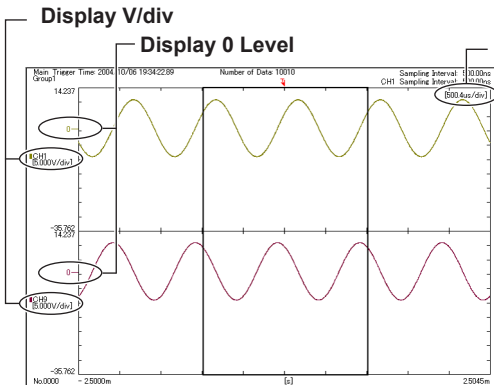

You can change the T/div character size. Click the T/div value, and then drag any of the four corners of the displayed frame.

(Not available in Annotation mode. For information on Annotation mode, see section 4.7.)

Displaying the Bit Label

You can display the bit names of the logic waveform in the waveform display window.

Displays the bit names

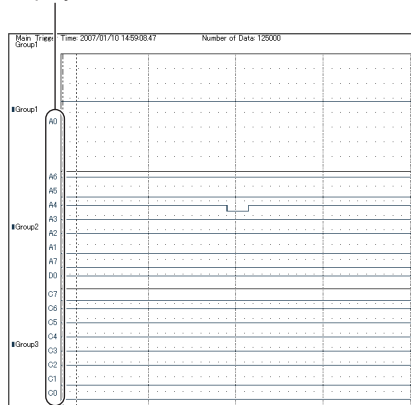

Note

- If the display area of the waveform display window is narrow, the bit label is not displayed. Carry out the following to display the bit label.
- Drag and expand the waveform display window vertically.
 - Reduce the number of screen divisions.

3.4 Specifying Display Settings

Displaying the Multiple Vertical Axes

If multiple waveforms are displayed in the waveform display window, the range of the vertical axis of each displayed waveform can be displayed.

Displays multiple vertical scales

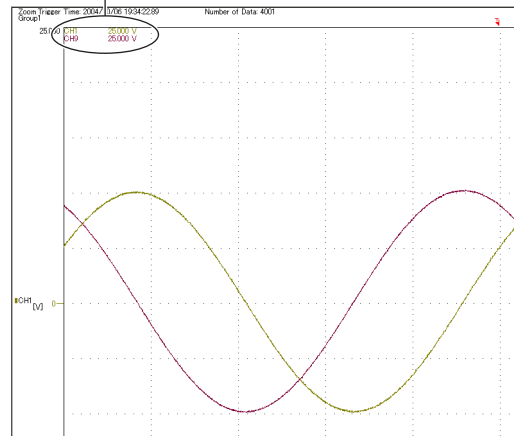

Note

Multiple vertical axes are not displayed if only a single waveform is shown in the waveform display window.

Checking the Changed Settings

Clicking **Apply** while you are changing settings applies the settings you have already made for the window(s) to the waveform display, without closing the Display Setting dialog box.

Note

The Supplementary Grid of the Graticule tab and the Scale of the Horizontal Axis tab can be set only on Xviewer with the computation option if the horizontal axis unit is Hz.

3.5 Turning Waveform Interpolation On and Off

Procedure

Turning Waveform Interpolation Off

Click **View > Waveform Interpolation > Off** to disable interpolation between sampled data points. Waveforms are displayed using dots.

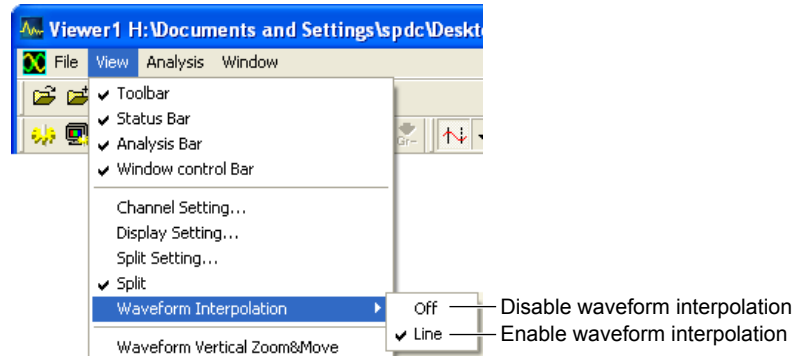

Turning Waveform Interpolation On

Click **View > Waveform Interpolation > Line** to display linearly interpolated waveforms.

Explanation

Waveform Interpolation

In interpolation zones in the T-Y waveform display,* Xviewer can display waveforms by interpolating between sampled data points.

* Interpolation zone refers to the condition in which a given number of data points are not contained in the 10 div along the time axis. The number of data points that causes the interpolation zone condition to occur varies depending on the display record length and zoom ratio.

- **Off**

Interpolation is disabled, and waveforms are displayed using dots. This mode makes it easy to view the actual data positions.

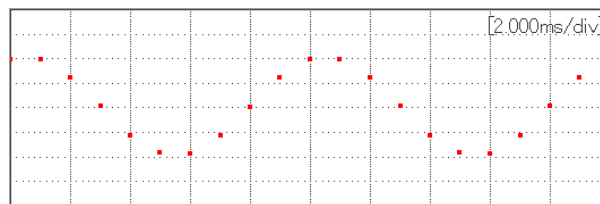

- **Line**

Linear interpolation is performed between two points.

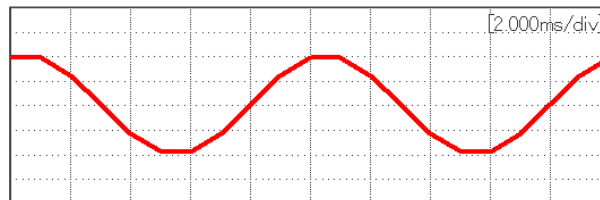

Note

When waveforms that have been saved with P-P Com ON are being displayed and waveform interpolation is turned off, only P-P compressed values (the maximum and minimum sampled data values per given period) are displayed.

3.6 Initializing Display Settings

Procedure

Executing Initialization

Click **File > Initialize Viewer** to return display conditions to their initial settings.

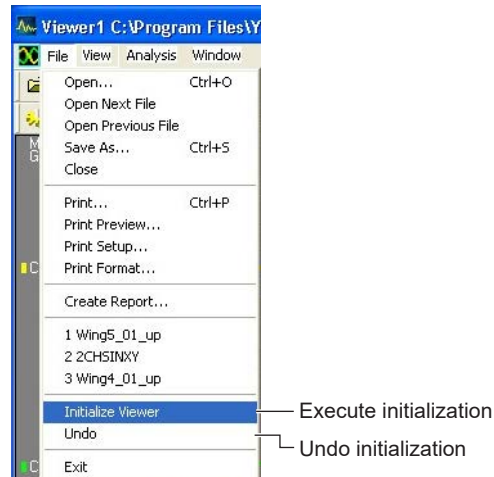

Undoing Initialization

Click **File > Undo** to restore the settings prior to the initialization.

Explanation

Initialization

Returns various kinds of specified display conditions to the settings immediately after loading the waveform data. This is useful when you wish to cancel all settings previously entered, or wish to reenter settings from the beginning.

Undoing Initialization

If you use the Undo command, the settings prior to the initialization are restored.

Initialized Items

The main items initialized are the following.

- Waveform color
- Color of the background, text, graticule, cursor, and window background
- Vertical axis scale values
- Logic signal display bit
- Number of screen divisions
- Sizes of windows
- Displayed windows (two: the main waveform display window and measurement result display window)
- Zoom position and zoom ratio
- Graticule type
- H and V cursor positions
- Horizontal and vertical axis display format
- Waveform parameter measurement items
- Computation filter, number of FFT computation points, time window, and user-defined computational expressions
- Deletion of all annotations

4.1 Displaying Measurement Results

Procedure

Displaying Measurements in the Result View

Open a waveform data file for which waveforms and measurement results are to be displayed. To display or hide the measurement result display window, click  or select **Window > Measure Result**.

Display or hide the measurement result display window

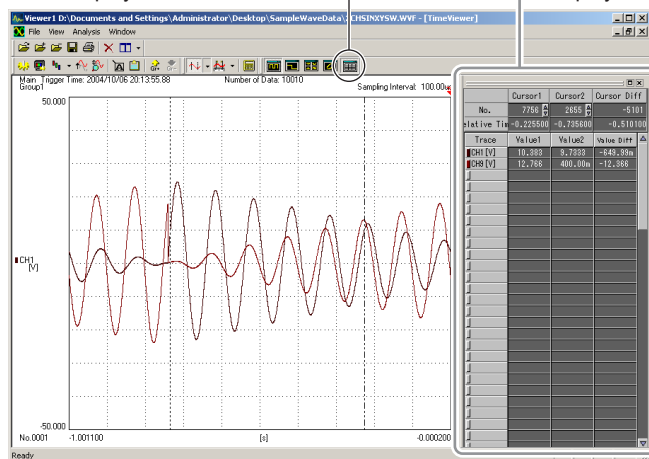

Explanation

Items and Measured Values That Are Displayed

The items and measured values that are displayed depend on the measurements and waveforms.

Reference to Cursor Positions

The positions of the cursors are indicated using either of the references below, according to the notational format of the horizontal axis:

- Absolute time: The positions of cursors are indicated as absolute times.
- Relative time: The positions of cursors are indicated as being relative to the trigger position.

Note

When the measurement results display window is not displayed and you execute cursor measurement, automated measurement of waveform parameters, automated measurement of history statistics, or automated measurement of cycle statistics, the measurement results display window will automatically appear.

4.2 Analyzing Waveform Data Using Cursors

Procedure

Analyzing Waveform Data Using Cursors

Choose **Vertical Cursor** from the  icon drop-down menu or choose **Analysis > Analysis Mode > Vertical Cursor** to display two vertical cursors in the main waveform display window and the zoomed waveform display window.

The measurement result window displays the cursor positions (time) and measured values as well as the difference in the time and measured values between the cursors. You can drag each cursor. You can click within the window to move Cursor 1 to that position. Likewise, you can right-click within the window to move Cursor 2 to that position.

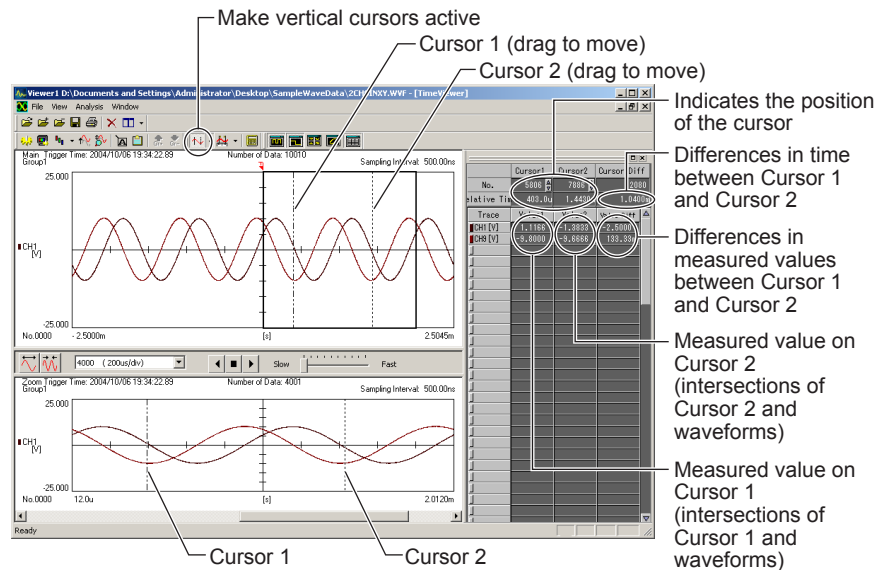

Note

If measured data is present at the cursor position, the intersections between the waveforms and cursor are indicated with circles.

If waveforms measured at different sample rates are displayed in the same window, measured data may not be present at the cursor position. For such a waveform, the circle is not displayed at the intersection between the waveform and cursor. However, measured value is displayed by interpolating from the previous measured value.

Analyzing Waveform Data Using Horizontal Cursors

Choose **Horizontal Cursor** from the  icon drop-down menu or choose **Analysis > Analysis Mode > Horizontal Cursor** to display two horizontal cursors in the main waveform display window and the zoomed waveform display window.

The measurement result window displays the measured value at each cursor.

You can drag each cursor. You can click the cursor value in the measurement result window and enter the value of the position you want to move the cursor to. The cursor will move to the specified position.

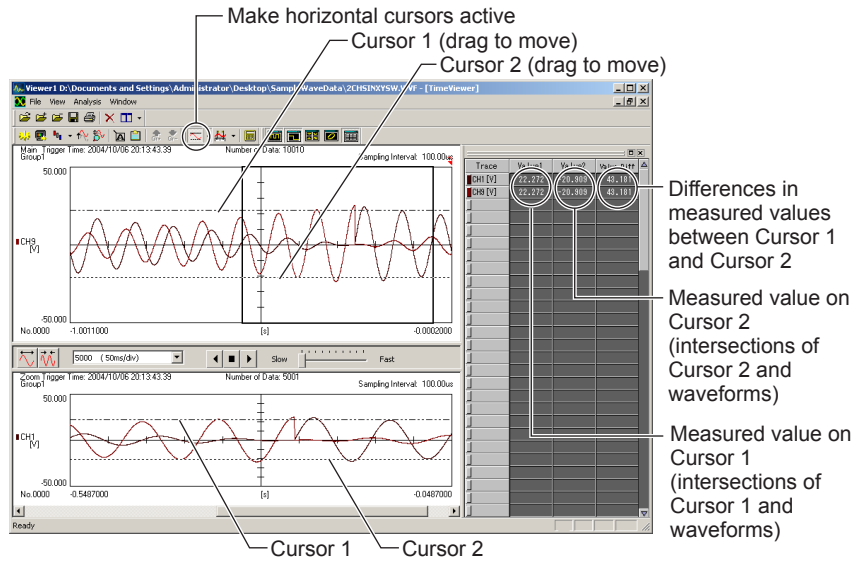

Note

In the following situations, horizontal cursors are not displayed in the zoom waveform display window.

- When the waveform shown in the main waveform display window and that shown in the zoom waveform display window are different (when “Share channel setting in Main/Zoom” is set to off).
- When waveforms are overlaid, the active waveform in the main waveform display window and that in the zoom waveform display window are different.

Analyzing Waveform Data Using X-Y Cursors

Choose **X-Y Cursor** from the  icon drop-down menu or choose **Analysis > Analysis Mode > X-Y Cursor** to display two vertical cursors and two horizontal cursors in the X-Y waveform display window. You can move a cursor by dragging it. The measurement result display window displays the measured values at the cursor positions at that time, as well as the differences in the measured values.

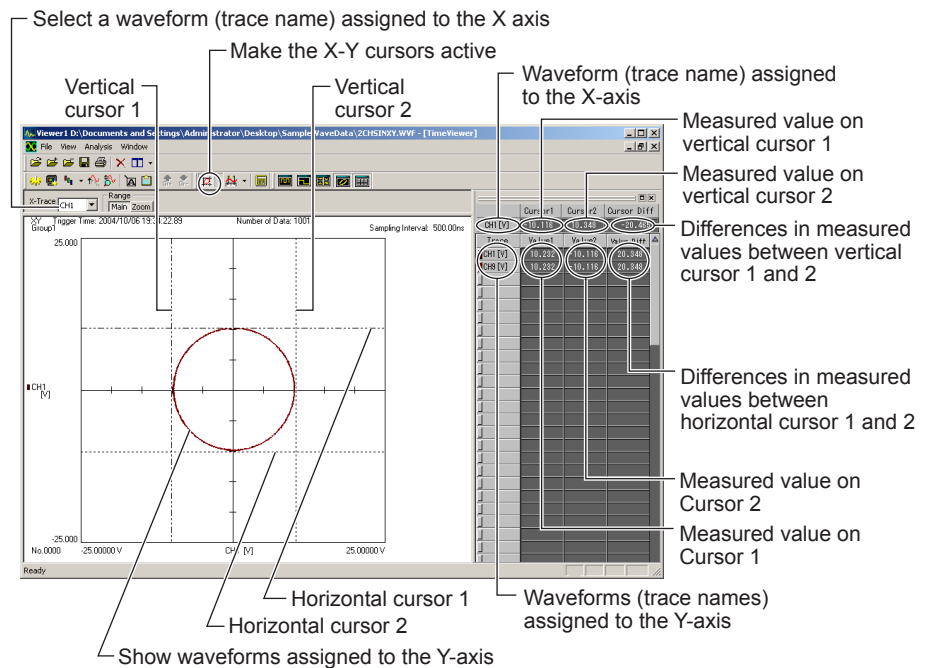

4.2 Analyzing Waveform Data Using Cursors

Analyzing Waveform Data Using H&V Cursors

Choose **H&V Cursor** from the  icon drop-down menu or choose **Analysis > Analysis Mode > H&V Cursor** to display four cursors (two vertical cursors and two horizontal cursors) in the main waveform display window and the zoomed waveform display window. The measurement result window displays the measured value at each cursor and the differences between the measured values between the cursors. In addition, you can click the horizontal cursor value in the measurement result window and enter the value of the position you want to move the horizontal cursor to. The cursor will move to the specified position.

Note

In the following situations, horizontal cursors are not displayed in the zoom waveform display window.

- When the waveform shown in the main waveform display window and that shown in the zoom waveform display window are different (when “Share channel setting in Main/Zoom” is set to off).
- When waveforms are overlaid, the active waveform in the main waveform display window and that in the zoom waveform display window are different.

Explanation

Cursor Measurements on History Waveform Views

When you are displaying history waveform views, only the active waveform view can be used for measurement using the cursors.

Linking of Vertical Cursors or Horizontal Cursors

If you drag a vertical cursor or horizontal cursor while holding down the Ctrl key, the two vertical or horizontal cursors can be moved simultaneously.

*** Indication

If the measurement result is invalid, “***” is displayed as the measured value.

Note

You can copy the contents of the measurement results display window to the clipboard. Specify the range to be copied, press Ctrl+C, then the measured results are copied to the clipboard. The following methods can be used to specify a range.

- Press Ctrl+C without specifying a range to copy:
All contents in the measurement results display window are selected.
- Click Trace:
All rows are selected except for the data at the cursor.
- Click the trace names of the items to copy:
The trace name row that you clicked is selected.

Selects all rows except the cursor information.
Click once again to clear the selection.

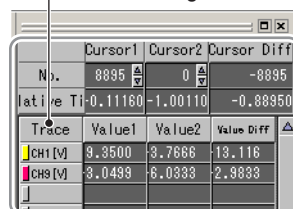

	Cursor1	Cursor2	Cursor Diff
No.	8895	0	-8895
Relative Tt	-0.11160	-1.00110	-0.88950
Trace	Value1	Value2	Value Diff
CH1 [V]	9.3500	9.7888	18.116
CH3 [V]	9.0499	8.0333	2.9833

If no range is specified,
all are copied.

4.3 Automated Measurement of Waveform



Procedure

Setting Items That Are Automatically Measured

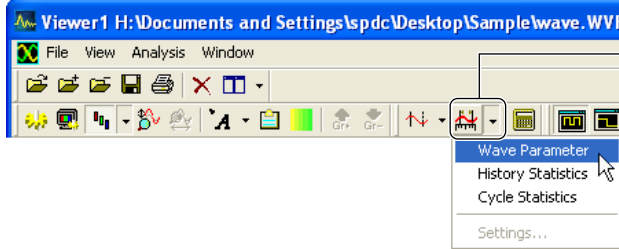
- From the  drop-down menu, select the **Wave Parameter**. Or click **Analysis > Waveform Parameter Settings > Wave Parameter**.



The icon changes according to what you select.

-  : Wave Parameter
-  : History Statistics
-  : Cycle Statistics

or

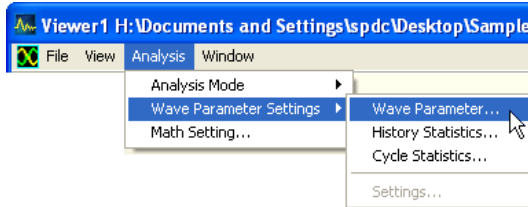

The Waveform Parameter Setting dialog box appears.

- In the Waveform Parameter Setting dialog box, set the measurement items and the conditions for displaying measured results, and then click **OK**.

Names of items to be measured
Select or deselect the item

Voltage measurement items

Time measurement items

Area measurement items

Place a checkmark to allocate traces to the vertical axis in the measurement result display window

Select the number of rows to be used to display measured values (allowable range: 1 to 28).

Select the measurement range.
All: The entire waveform is measured.
Cursor range: The cursor range is measured.

Displays the channel setting window (see section 3.2)

Start automated measurement

Automated measurement starts. Two vertical cursors are displayed in the main waveform display window, and the measured results of waveform parameters are displayed in the measurement results display window.

4.3 Automated Measurement of Waveform

Specifying the Automated Measurement Range

When the measurement range is set to Cursor range, you can change the range over which to perform automated measurement of waveform parameters. Drag the two vertical cursors to change the measurement start point and the measurement end point. Waveform parameters are remeasured automatically.

When the measurement range is set to All, moving the cursors will not cause waveform parameters to be remeasured.

Operations in the Waveform Parameter's Automated Measurement Screen

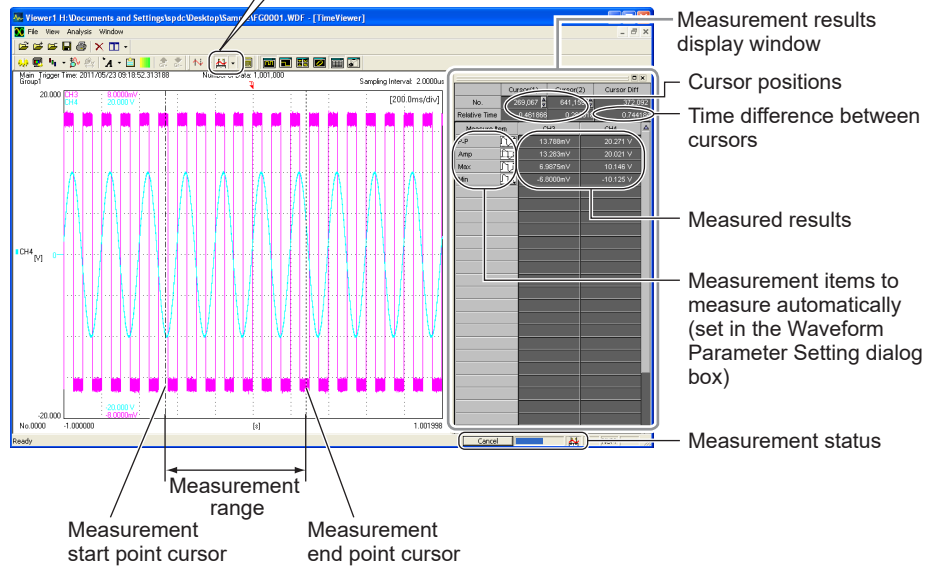
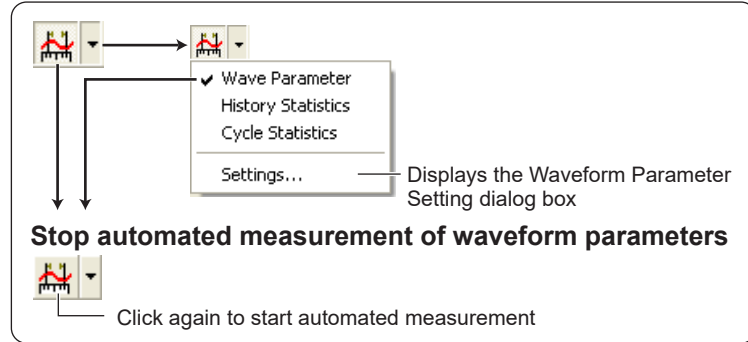

Explanation

Items that Can Be Specified

On the waveform parameters, you can set and measure voltage, time and area items. You can also set the distal line, mesial line, proximal line, and high and low values for each channel on the channel setting window. (see section 3.2).

Note

- When the scope to analyze includes two cycles or more of a waveform, time-axis parameters are analyzed only for the first cycle.
- An FFT computation allows to make measurement only for Max and Min.
- No logic waveform can be automatically analyzed.

• Voltage measurement items

Maximum: Maximum voltage [V]	Average: Average voltage $(1/n)\sum xi$ [V]
Minimum: Minimum voltage [V]	RMS: Root-mean-square value $(1/\sqrt{n})(\sum xi^2)^{1/2}$ [V]
High level: High voltage [V]	Middle: Mean value for amplitude $(Max + Min)/2$ [V]
Low level: Low voltage [V]	Standard deviation: Standard deviation $(1/n(\sum x^2 - (\sum x)^2/n))^{1/2}$
Peak to peak value: P-P value $(Max - Min)$ [V]	Overshoot: Amount of overshoot $(Max - High)/(High - Low) \times 100$ [%]
Amplitude: Amplitude $(High - Low)$ [V]	Undershoot: Amount of undershoot $(Low - Min)/(High - Low) \times 100$ [%]

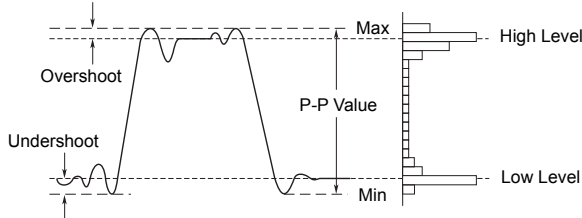

• Time measurement items

Rise time: Rise time [s]	Plus duty: Duty ratio, $Width1/Period \times 100$ [%]
Fall time: Fall time [s]	Minus duty: Duty ratio, $Width2/Period \times 100$ [%]
Frequency: Frequency [Hz]	Plus width: Time width greater than the mesial value [s]
Period: Cycle [s]	Minus width: Time width less than the mesial value [s]

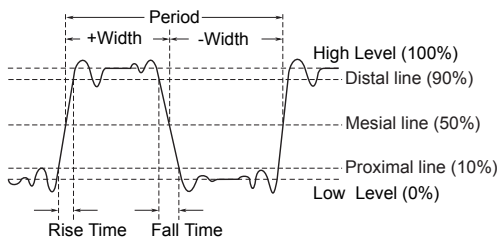

Pulse: Pulse count Adjust the measurement scope to the pulses you want to measure.

When Pulse=3

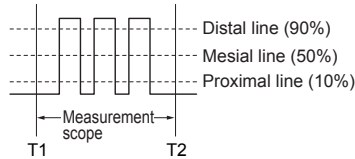

Burst1, Burst2: Burst width [s] Adjust the measurement scope to the burst widths you want to measure.

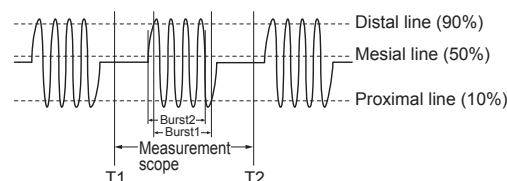

4.3 Automated Measurement of Waveform

• **Area measurement items**

Int1TY: Size of the positive portion of an amplitude

Int2TY: Size of the positive portion of an amplitude - Size of the negative portion of an amplitude

- Int1XY: • Total area in which the start and stop points trace multiple identical closed curves
 • Area enclosed by a curve connecting the start and stop points
 • Area in which the start and stop points trace the shape of an "8"
 • Area in which the start and stop points trace a closed curve in a spiral loop

- Int2XY: • When 1 Y data point corresponds to 1 X data point
 • When the amplitude contains negative sections
 • When multiple Y data points correspond to 1 X data point

Int1TY

Size of only the positive areas: $S_1 + S_2$

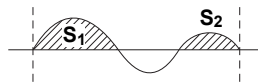

Int2TY

Size of both positive and negative areas: $S_1 + S_3 - S_2$

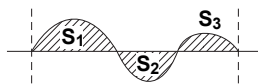

Int1XY

(1) Multiple loops

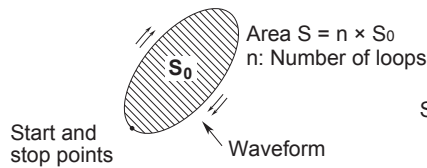

(2) Non-closed curve

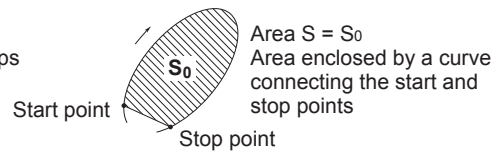

(3) Loop tracing the shape of an "8"

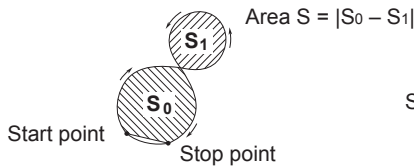

(4) Spiral loop

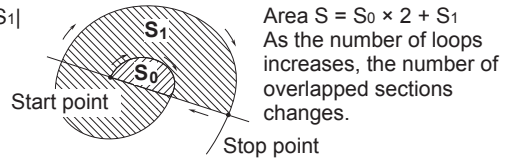

Int2XY

(1) When 1 Y data point corresponds to 1 X data point

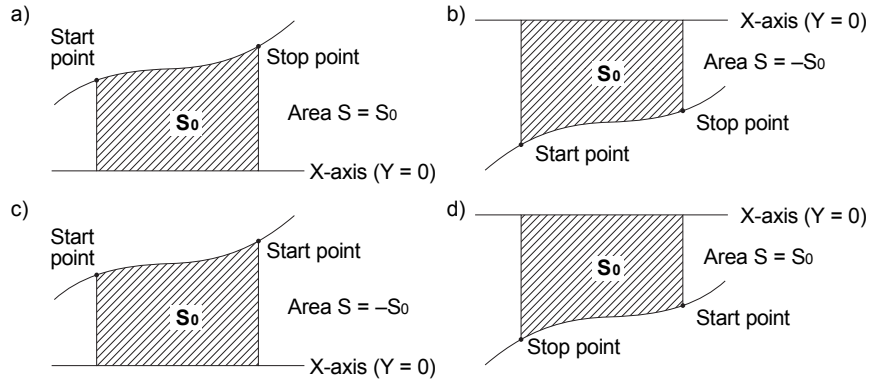

(2) When the waveform contains negative amplitude

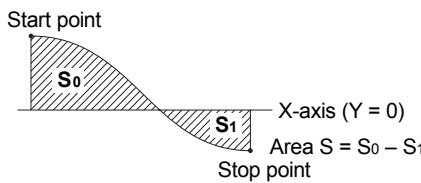

(3) When multiple Y data points correspond to 1 X data point

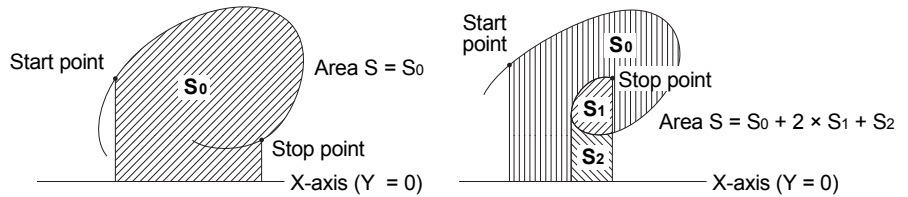

***** Indication**

If the measurement result is invalid or impossible, “***” is displayed as the measured value. Waveforms with small amplitudes may fail to produce correct readings.

Note

On version 1.78 and later, channels whose sample rate is different from the sample rate of the X-axis channel are excluded from measurement (***) display).

Icon Displayed during Automatic Measurement

While automatic measurement is being performed, the icon shown below appears in the status bar.

: Performing automatic measurement (blinks on and off)

Note

- It may take a long time to automatically analyze a waveform with some conditions for the scope, number of items, and/or waveforms to analyze. For example, if the measurement item is Pulse count, Burst1, Burst2, Average frequency, or Average period and the number of data points exceeds 1 Mpoint, computation will take a long time.
- Canceling automated measurement
While automated measurement is in progress, a cancel button and a progress bar are displayed in the status bar. Click the Cancel button to cancel automated measurement.



4.3 Automated Measurement of Waveform

Data Obtained through Automatic Measurements with Waveform Parameters

To keep the obtained data, save it into a file. For details, see Section 5.4.

Note

You can copy the contents of the measurement results display window to the clipboard.

Specify the range to be copied, and press Ctrl+C, then the measured results are copied to the clipboard. The following methods can be used to specify a range.

- Press Ctrl+C without specifying a range to copy:
All the contents in the measurement results display window are selected
- Click Measure Item:
All rows are selected except for the data at the cursor.
- Click the measurement items of the items to copy:
The rows of the clicked items are selected

Click here to select all rows except the cursor information.
Click once again to clear the selection.

	Cursor1	Cursor2	Cursor Diff
No.	774	0	-774
Relative Time	- 4.2260m	- 5.0000m	- 774.0u
Measure Item	CH1 [V]	CH2 [V]	
P-P	1.0088	833.33m	
Amp	994.99m	166.66m	
Max	1.0098	333.33m	
Min	- 2.2228	- 500.00m	

If no range is specified, all contents are copied

4.4 Automated Measurement of History Statistics



Procedure

Setting Items That Are Automatically Measured

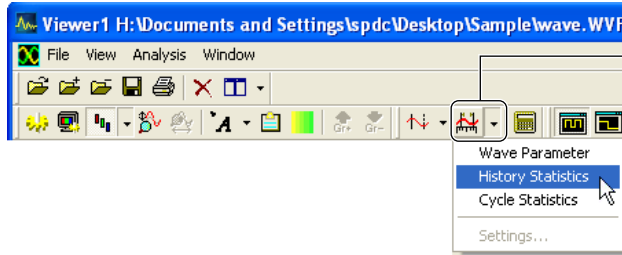
- From the  drop-down menu, select **History Statistics**. Or click **Analysis > Waveform Parameter Settings > History Statistics**.



The icon changes according to what you select.

-  : Wave Parameter
-  : History Statistics
-  : Cycle Statistics

or

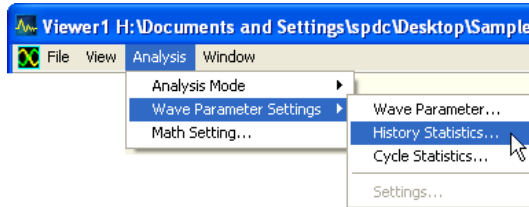

The History Statistics Settings dialog box appears.

- In the History Statistics Settings dialog box, set the measurement items and the conditions for displaying measured results, and then click **OK**.

The 'History Statistics Settings' dialog box contains a list of measurement items on the left, categorized into Voltage, Time, and Area measurement items. On the right, there are settings for 'Number of column' (1-28), 'Histogram Settings' (Display checkbox, Linear/Log radio buttons), 'Measure Range' (Cursor range dropdown), and 'Channel Setting' (button). The 'OK' and 'Cancel' buttons are at the bottom.

Annotations:

- Names of items to be measured:** Points to the list of measurement items.
- Select or deselect the item:** Points to the checkboxes next to the items.
- Select the number of rows to be used to display measured values (allowable range: 1 to 28):** Points to the 'Number of column' dropdown.
- Select this check box to display the histogram of statistics in the measurement results display window:** Points to the 'Display' checkbox in Histogram Settings.
- Use a linear scale to display the histogram's Y axis:** Points to the 'Linear' radio button.
- Use a logarithmic scale to display the histogram's Y axis:** Points to the 'Log' radio button.
- Select the measurement range. All: The entire waveform is measured. Cursor range: The cursor range is measured:** Points to the 'Measure Range' dropdown.
- Displays the channel setting window (see section 3.2):** Points to the 'Channel Setting' button.
- Start automated measurement:** Points to the 'OK' button.

Automated measurement starts. Two vertical cursors appear in the main waveform display window, and the measured history statistics are displayed in the measurement results display window.

4.4 Automated Measurement of History Statistics

Specifying the Automated Measurement Range

When the measurement range is set to Cursor range, you can change the range over which to perform automated measurement of history statistics. Drag the two vertical cursors to change the measurement start point and the measurement end point. History statistics are remeasured automatically.

When the measurement range is set to All, moving the cursors will not cause history statistics to be remeasured.

Operations in the History Statistics' Automated Measurement Screen

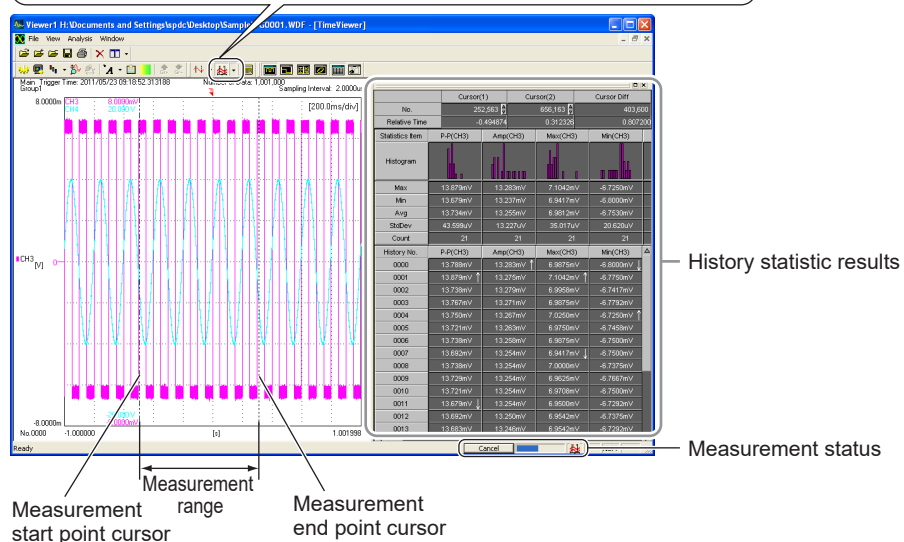
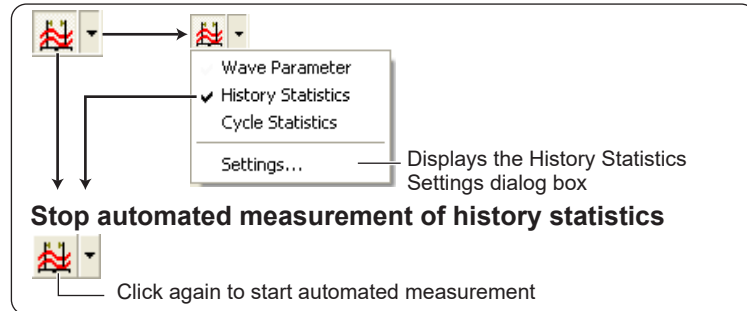

Displaying History Statistic Results

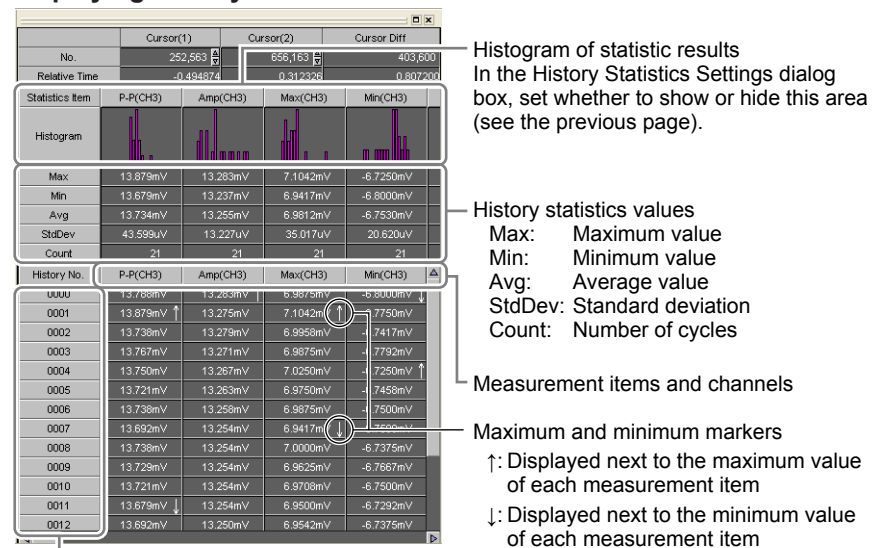

History numbers

Double-click a history number to display the corresponding history waveform.

Explanation

Items That Can Be Measured

On the history waveforms, you can set and measure voltage, time and area items. Items that can be measured are the same as those of the automated measurement of waveform parameters (see page 4-7 to 4-9).

***** Indication**

If the measurement result is invalid or impossible, “****” is displayed as the measured value. Waveforms with small amplitudes may fail to produce correct readings.

Icon Displayed during Automated Measurement

While automatic measurement is being performed, the icon shown below appears in the status bar.

 : Performing automate measurement (blinking)

Note

- Canceling history statistic measurement
While history statistic measurement is in progress, a cancel button and a progress bar are displayed in the status bar. Click the Cancel button to cancel history statistic measurement.



- If the total number of items that is determined by the number of history waveforms, the number of channels, and the number of measurement items exceeds 100000, computation may not be possible. Change the number of displayed channels and measurement items so that 100000 is not exceeded.

Saving History Statistics' Automated Measurement Data

To save the measured results, save them to a file. For details, see section 5.4.

Note

You can copy the contents of the measurement results display window to the clipboard. Specify the range to be copied, and press Ctrl+C. The measured results are copied to the clipboard.

The following methods can be used to specify the range.

- Press Ctrl+C without specifying a range to copy:
All the contents in the measurement results display window are selected.
- Click Trace:
All rows are selected except for the cursor position information and the histograms.
- Click or drag the trace names of the items to copy:
The rows of the clicked or dragged traces are selected.

Click here to select all rows except for the cursor position information and the histograms. Click once again to clear the selection.

	Cursor(1)	Cursor(2)	Cursor Diff	
No.	252,563	656,163	403,600	
Relative Time	-0.494874	0.312326	0.807200	
Statistics Item	P-P(CH3)	Amp(CH3)	Max(CH3)	Min(CH3)
Histogram				
Max	13.879mV	13.283mV	7.1042mV	-6.7250mV
Min	13.679mV	13.237mV	6.9417mV	-6.8000mV
Avg	13.734mV	13.255mV	6.9812mV	-6.7530mV
StdDev	43.599uV	13.227uV	35.017uV	20.620uV
Count	21	21	21	21
History No.	P-P(CH3)	Amp(CH3)	Max(CH3)	Min(CH3)
0000	13.788mV	13.283mV	6.9875mV	-6.8000mV
0001	13.879mV	13.275mV	7.1042mV	-6.7750mV
0002	13.738mV	13.279mV	6.9958mV	-6.7417mV

If no range is specified, all contents are copied

4.5 Automated Measurement of Cycle Statistics



Procedure

Setting Items That Are Automatically Measured

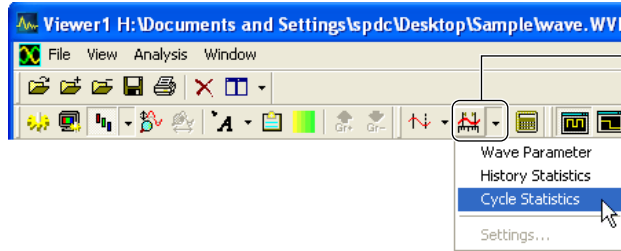
- From the  drop-down menu, select **Cycle Statistics**. Or click **Analysis > Waveform Parameter Settings > Cycle Statistics**.



The icon changes according to what you select.

-  : Wave Parameter
-  : History Statistics
-  : Cycle Statistics

or

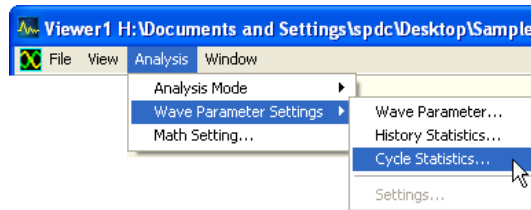

The Cycle Statistics Settings dialog box appears.

- In the Cycle Statistics Settings dialog box, set the measurement items and the conditions for displaying measured results, and then click **OK**.

The 'Cycle Statistics Settings' dialog box contains a table for defining measurement items and various configuration options. Annotations explain the purpose of these options:

- Traces and measurement items to perform cycle statistic measurement (up to eight items):** Points to the table with columns 'No.', 'Trace', and 'Measure Item'.
- Names of the traces to be measured:** Points to the 'Trace' column.
- Names of items to be measured:** Points to the 'Measure Item' column.
- Select the reference trace for cycle statistic measurements:** Points to the 'Cycle' dropdown menu.
- Select the number of rows to be used to display measured values (allowable range: 1 to 8):** Points to the 'Number of column:' dropdown.
- Select the measurement range. All: The entire waveform is measured. Cursor range: The cursor range is measured.** Points to the 'Measure Range:' dropdown.
- Select cycle number, absolute time, or relative time.** Points to the 'Cycle No.:' dropdown.
- Select this check box to display the histogram of statistics in the measurement results display window.** Points to the 'Display' checkbox.
- Use a linear scale to display the histogram's Y axis.** Points to the 'Linear' radio button.
- Use a logarithmic scale to display the histogram's Y axis.** Points to the 'Log' radio button.
- Start automated measurement:** Points to the 'OK' button.
- Displays the channel setting window (see section 3.2):** Points to the 'Channel Setting' button.

No.	Trace	Measure Item
1	CH1	None
2	CH1	None
3	CH1	None
4	CH1	None
5	CH1	None
6	CH1	None
7	CH1	None
8	CH1	None

Automated measurement starts. Two vertical cursors appear in the main waveform display window, and the measured cycle statistics are displayed in the measurement results display window.

Specifying the Automated Measurement Range

When the measurement range is set to Cursor range, you can change the range over which to perform automated measurement of cycle statistics. Drag the two vertical cursors to change the measurement start point and the measurement end point. Cycle statistics are remeasured.

When the measurement range is set to All, moving the cursors will not cause cycle statistics to be remeasured.

Operations in the Cycle Statistics' Automated Measurement Screen

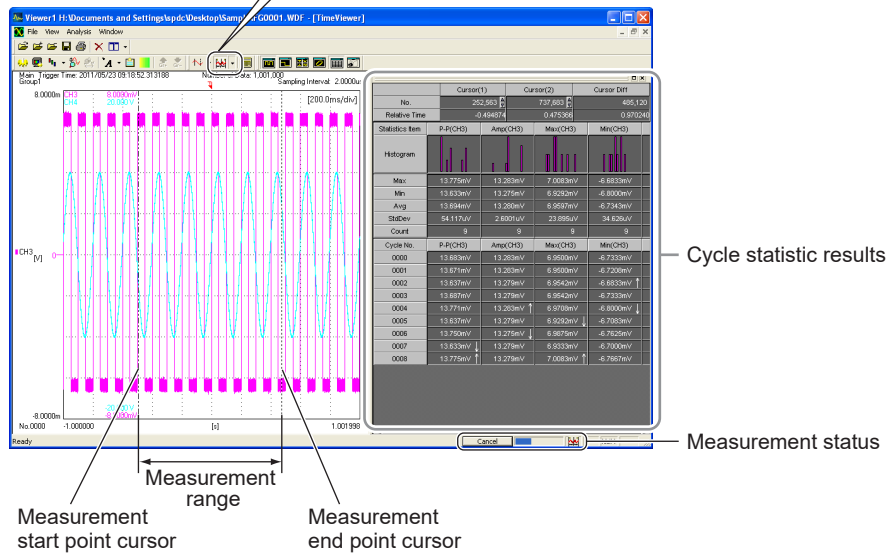
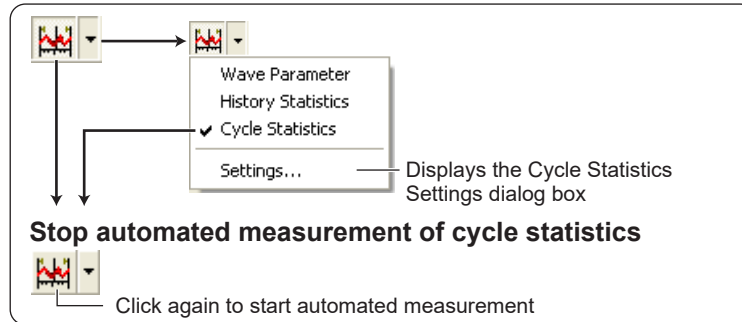

Displaying Cycle Statistic Results

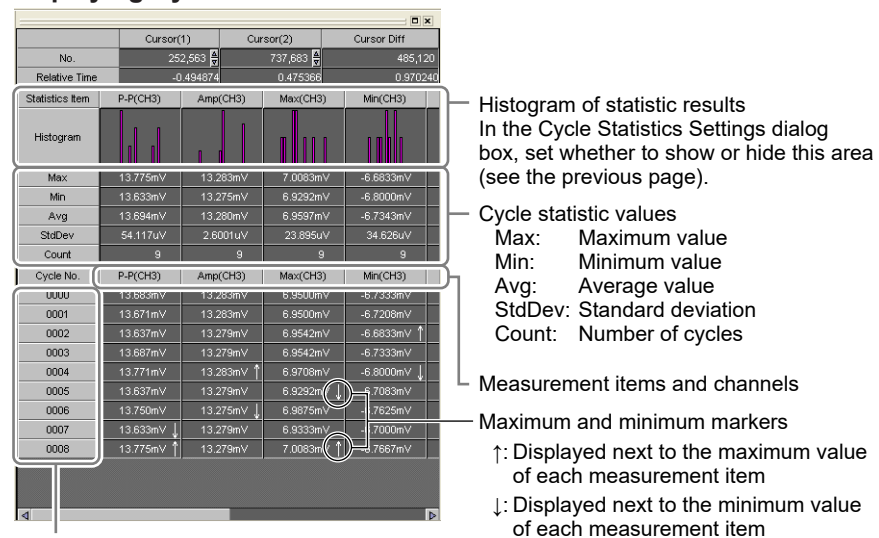

Cycle number/measurement time
Double-click a cycle number to display the corresponding cycle waveform.

Explanation

Items That Can Be Measured

On each period of the waveforms, you can set and measure voltage, time and area items. Items that can be measured are the same as those of the automated measurement of waveform parameters (see page 4-7 to 4-9).

Cycle Trace

Select the trace that will be used as the reference cycle for performing cycle statistic measurement. If Own has been selected, cycle statistic measurement is performed using each trace's cycle. Cycle statistic result window will show the measured results over the time period for the least number of cycles.

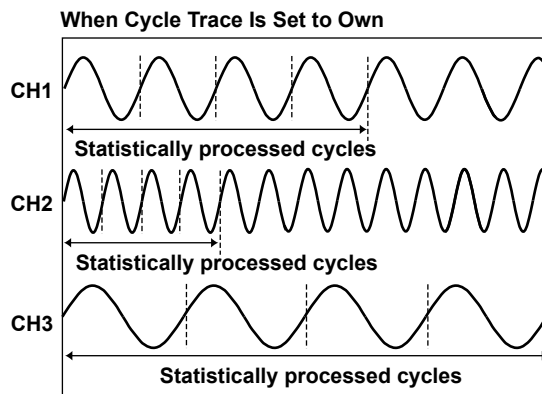

The number of cycles in the channel with the slowest cycle (CH3) is four, so statistical processing is performed on the four oldest cycles of the data for CH1 and CH2. The remaining data is not used for statistical processing.

***** Indication**

If the measurement result is invalid or impossible, "***" is displayed as the measured value. Waveforms with small amplitudes may fail to produce correct readings.

Note

If the trace to perform cycle statistic measurement on is set to a waveform whose measurement interval is different from the waveform assigned to the cycle trace, measured results will be "***."

Icon Displayed during Automated Measurement

While automatic measurement is being performed, the icon shown below appears in the status bar.

 : Performing automate measurement (blinking)

Note

- Canceling cycle statistic measurement
While cycle statistic measurement is in progress, a cancel button and a progress bar are displayed in the status bar. Click the Cancel button to cancel cycle statistic measurement.



- If the total number of items that is determined by the number of cycles and the number of measurement items exceeds 100000, computation may not be possible. Change the measurement range and the number of measurement items so that 100000 is not exceeded.

Saving Cycle Statistics' Automated Measurement Data

To save the measured results, save them to a file. For details, see section 5.4.

Note

You can copy the contents of the measurement results display window to the clipboard. Specify the range to be copied, and press Ctrl+C. The measured results are copied to the clipboard. The following methods can be used to specify the range.

- Press Ctrl+C without specifying a range to copy:
All the contents in the measurement results display window are selected.
- Click Trace:
All rows are selected except for the cursor position information and the histograms.
- Click or drag the trace names of the items to copy:
The rows of the clicked or dragged traces are selected.

Click here to select all rows except for the cursor position information and the histograms. Click once again to clear the selection.

	Cursor(1)	Cursor(2)	Cursor Diff	
No.	252,563	737,683	485,120	
Relative Time	-0.494874	0.475366	0.970240	
Statistics Item	P-P(CH3)	Amp(CH3)	Max(CH3)	Min(CH3)
Histogram				
Max	13.775mV	13.283mV	7.0083mV	-6.6833mV
Min	13.633mV	13.275mV	6.9292mV	-6.8000mV
Avg	13.694mV	13.280mV	6.9597mV	-6.7343mV
StdDev	54.117uV	2.6001uV	23.895uV	34.626uV
Count	9	9	9	9
Cycle No.	P-P(CH3)	Amp(CH3)	Max(CH3)	Min(CH3)
0000	13.683mV	13.283mV	6.9500mV	-6.7333mV
0001	13.671mV	13.283mV	6.9500mV	-6.7208mV
0002	13.637mV	13.279mV	6.9542mV	-6.6833mV

If no range is specified, all contents are copied

4.6 Analyzing Waveforms by Computations (Math Edition)

Procedure

Displaying Waveforms in the Computation View

Click  or select **Analysis > Math Setting** to display the Math Setting dialog box for analyzing waveforms by computational expressions. The Math Setting dialog box allows you to set computational expressions, filters, FFT computations, and other computations for waveforms.

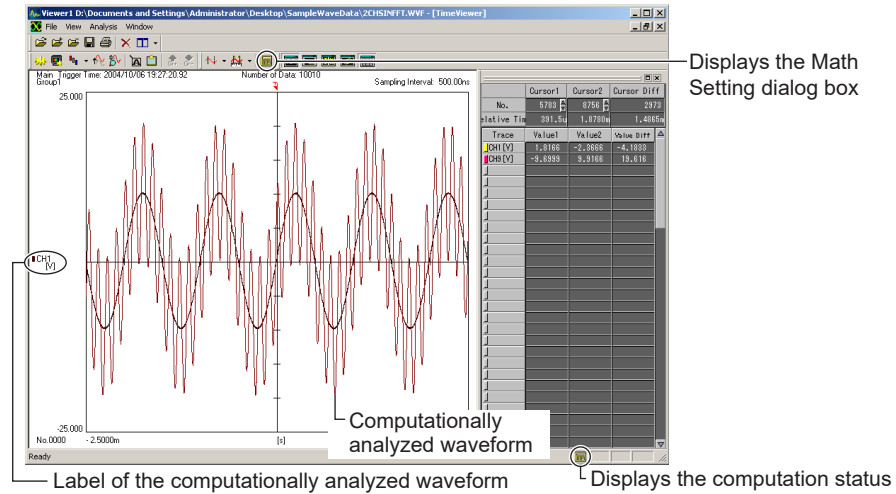

Setting Computational Expressions

Click **Expression** in the Math Setting dialog box to display the Computational Expression screen, which allows you to specify user-defined computation settings. Set up a required computational expression by using variables and operators.

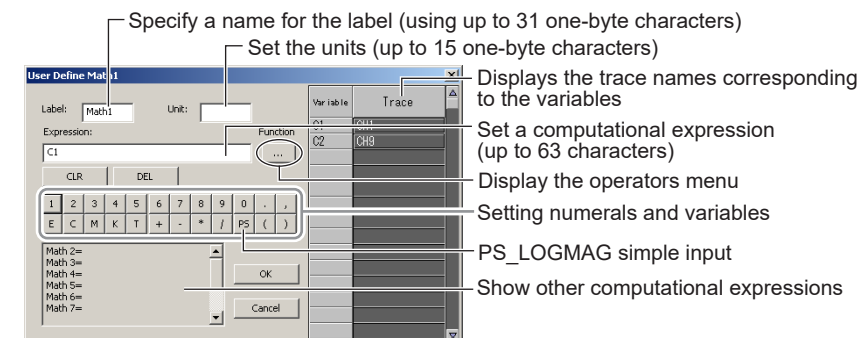
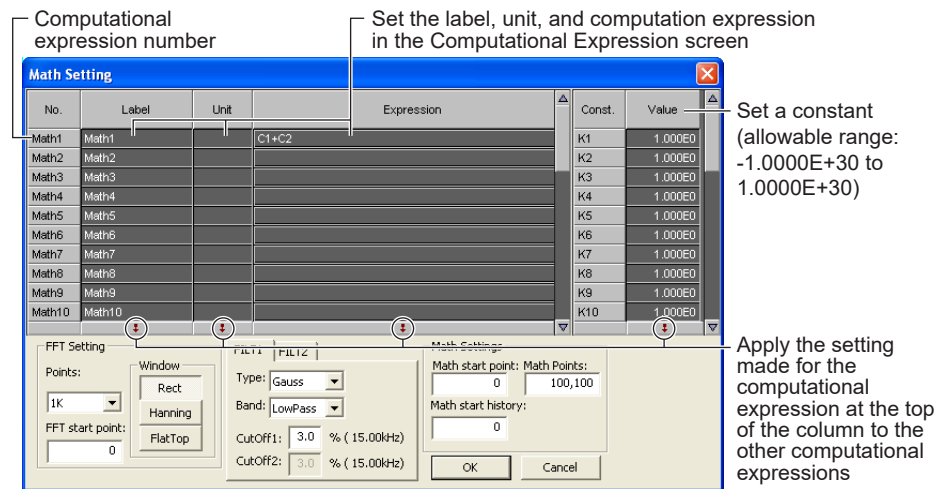

Setting Filters

Use the FILT1 and FILT2 tabs on the Math Setting dialog box to set up the filters.

Setting the Computation Start Point, the number of Computation Points and Start History

- You can set the computation range by specifying the computation start point and the number of computation points. You can also change the computation range by adjusting the computation range bar, which is displayed in the waveform display window.
- With history waveforms, you can set the number of the history waveform on which to start computation (computation start history), the computation start point, and the number of computed points. With this computation setting, waveforms are assigned in order from 0 to positive integers starting with the oldest waveform.

Note

The maximum number of computed points is 12.5 Mpoints (2.5 Mpoints if there are 11 or more MATH channels).

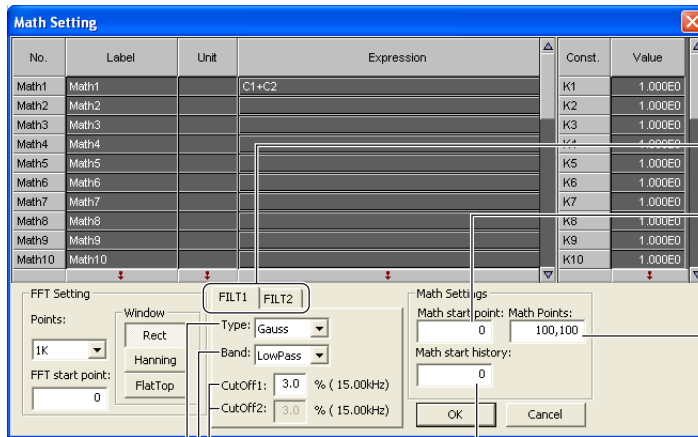

Switch between the filter 1 and filter 2 panels

Set the computation start point (0 to the number of waveform points).

Set the number of computation points. (When the number of math channels is 10 or less: 1 to 12.5 M When the number of math channels is 11 or more: 1 to 2.5 M)

Set the cut-off frequency

Select the band

Select the type

Set the number of the history waveform on which to start computation

Specifying FFT Settings

Use FFT Setting on the Math Setting dialog box to specify the FFT settings.

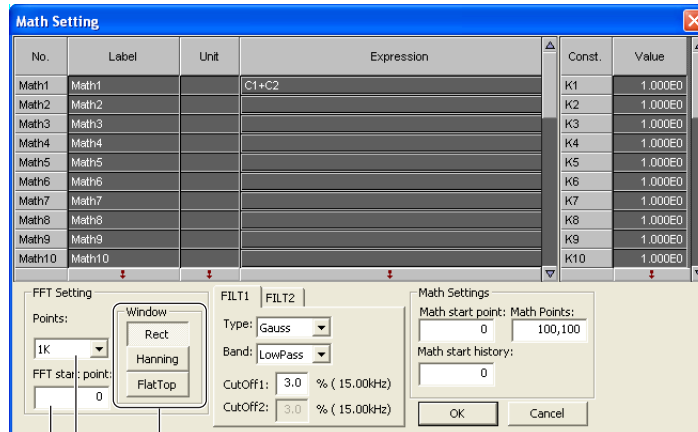

Select a time window type

Select the number of points to be used for FFT computations

Set the FFT start point

Explanation

Function Menu Button

The Function menu button of the Computational Expression dialog box contains operators that can be specified for user-defined computational expressions, as follows:

Basic	SHIFT, ABS, SQRT, LOG, EXP, RMS, NEG, P2, P3, F1, F2	
Trigonometric	SIN, COS, TAN, ATAN, PH	
Pulse Width	PWHL, PWLH, PWLL, PWXX, FV, DUTYH, DUTYL	
DIF & INTG	DIF, DDIF, INTG, IINTG	
Filter	FILT1, FILT2, HLB, MEAN, BIN	
FFT	LS	LS-REAL, LS-IMAG, LS-MAG, LS-LOGMAG, LS-PHASE
	RS	RS-MAG, RS-LOGMAG
	PS	PS-MAG, PS-LOGMAG, PSD-MAG, PSD-LOGMAG
	CS	CS-REAL, CS-IMAG, CS-MAG, CS-LOGMAG, CS-PHASE
	TF	TF-REAL, TF-IMAG, TF-MAG, TF-LOGMAG, TF-PHASE
	CH	CH-MAG

Restrictions Imposed on Computational Expressions

- When $m \leq n$, a computational expression for Mathn cannot include the variable M_n (Operations for Mathn).
Example of an expression that is not allowed: $\text{Math5} = M_6 + M_3$
- One FFT computation allows the specification of one waveform.
Example of an expression that is not allowed: $\text{PS-MAG}(C_1+C_2)$
- A computation cannot be performed on the result of an FFT computation.
Example of an expression that is not allowed: $\text{PS-MAG}(C_1)+C_2$

Cautions on Computations

- An FFT computation that does not have a record length that is sufficient for the required number of points for computation in the target view cannot be performed.

Settings for the Filters

- **Type/Band**
 Gauss (gauss): Lowpass
 Sharp (sharp): Lowpass/Highpass/Bandpass
 IIR (butterworth): Lowpass/Highpass/Bandpass
- **CutOff1/CutOff2**
 Set either or both cutoff frequencies as a ratio to the sampling frequency. The allowable range is 2.0% to 30.0% (0.2% steps). When you specify Bandpass for Band, specify the orders of both CutOff1 and CutOff2. The higher the order, the longer the computation.

Computation Start Point

When computation is executed, the computation start point and the computation range bar appear. You can move the computation start point by dragging the computation start point mark or the left edge of the computation range bar.

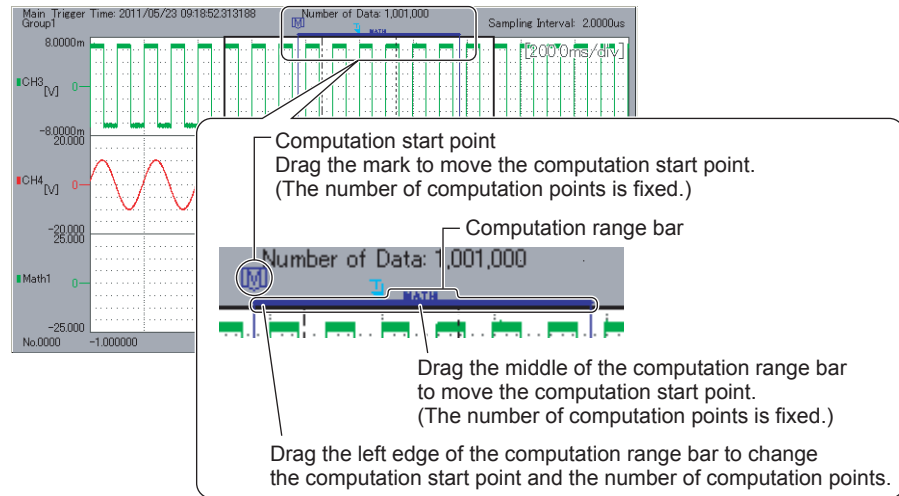

Number of Points for Computation

- When you click the left edge of the computation range bar, a horizontal arrow cursor appears. You can drag the edge to change the computation start point and the number of computation points. When you click the right edge of the computation range bar, a horizontal arrow cursor appears. In this situation, you can only change the number of computation points.
- When computing waveforms with different sample rates, the data of waveforms that are not measured at the highest sample rate is interpolated using the data immediately before it so that the waveform is at the highest sample rate.

Variables and Operators

The variables and operators that can be used in computational expressions are listed below. You can use up to 63 characters to define a computational expression. You can register up to 32 computational expressions.

Variables

Variable	Sample Use	Description
Cx	C1+C2	Value measured on channel CHx
My	ABS(M1)	Value of computation (Math)
A	BIN(C1,A,B)	Upper threshold level
B	BIN(C1,A,B)	Lower threshold level
N	SHIFT(C1,N)	Integrated value for the number of data points to the time axis
T	RMS(C1,T)	Computation time (ms)

x: stands for a number. However, specify the number according to the number of channels that are loaded. For example, if three channels, CH1, CH5, and CH8, are loaded, specify the channels as C1, C2, and C3.

y: stands for a number

Operator

Operator	Sample Use	Description
+, -, *, /	C1+C2	Four arithmetical Operations on two specified waveforms
SHIFT	SHIFT(C1,N)	Phase shift
ABS	ABS(M1)	Absolute value of a specified waveform
SQRT	SQRT(C2)	Square root of a specified waveform
LOG	LOG(C1)	Logarithm of a specified waveform
EXP	EXP(C1)	Exponent of a specified waveform
RMS	RMS(C1,T)	RMS value of the specified waveform

4.6 Analyzing Waveforms by Computations (Math Edition)

Operator	Sample Use	Description
NEG	NEG(C1)	Inversion
SIN	SIN(C1)	Sine of a specified waveform
COS	COS(C1)	Cosine of a specified waveform
TAN	TAN(C1)	Tangent of a specified waveform
ATAN	ATAN(C1,C2)	Arctangent of two specified waveforms (value within $\pm \pi$)
P2	P2(C1)	Square of a specified waveform
P3	P3(C1)	Cube of a specified waveform
F1	F1(C1,C2)	$\sqrt{ C1^2 + C2^2 }$ of a specified waveform
F2	F2(C1,C2)	$\sqrt{ C1^2 - C2^2 }$ of a specified waveform
K1toK10	C1 + K1	Constant (any value specified)
BIN	BIN(C1,A,B)	Binarization of a specified waveform
PWHH	PWHH(M1,A,B)	Computation of a pulse width between a rising edge and the next rising edge
PWHL	PWHL(C2,A,B)	Computation of a pulse width between a rising edge and the next falling edge
PWLH	PWLH(C1,A,B)	Computation of a pulse width between a falling edge and the next rising edge
PWLL	PWLL(C1,A,B)	Computation of a pulse width between a falling edge and the next falling edge
PWXX	PWXX(C2,A,B)	Computation of a pulse width between a raising/falling edge and the next rising/falling edge
FV	FV(C1,A,B)	PWHH reciprocal
DUTYH	DUTYH(C1,A,B)	Duty cycle between a rising edge and the next rising edge
DUTYL	DUTYL(C1,A,B)	Duty cycle between a falling edge and the next falling edge
MEAN	MEAN(C1)	10th moving average of a specified waveform
DIF	DIF(C1)	Differentiation of a specified waveform
DDIF	DDIF(C1)	Second-order derivative of a specified waveform
INTG	INTG(C1)	Integration of a specified waveform
IINTG	IINTG(C1)	Second-order integration of a specified waveform
PH	PH(C1,C2)	Phases of two specified waveforms
HLBT	HLBT(C1)	Hilbert function of a specified waveform
FILT1	FILT1(C1)	Filter for a specified waveform
FILT2	FILT2(C1)	Filter for a specified waveform
LS-REAL	LS-REAL(C1)	Real part of the linear spectrum of a specified waveform
LS-IMAG	LS-IMAG(C1)	Imaginary part of the linear spectrum of a specified waveform
LS-MAG	LS-MAG(C1)	Amplitude of the linear spectrum of a specified waveform
LS-LOGMAG	LS-LOGMAG(C1)	Logarithmic amplitude of the linear spectrum of a specified waveform
LS-PHASE	LS-PHASE(C1)	Phase of the linear spectrum of a specified waveform
RS-MAG	RS-MAG(C1)	Amplitude of the effective spectrum of a specified waveform
RS-LOGMAG	RS-LOGMAG(C1)	Logarithmic amplitude of the effective spectrum of a specified waveform
PS-MAG	PS-MAG(C1)	Amplitude of the power spectrum of a specified waveform
PS-LOGMAG	PS-LOGMAG(C1)	Logarithmic amplitude of the power spectrum of a specified waveform
PSD-MAG	PSD-MAG(C1)	Amplitude of the power spectrum density of a specified waveform
PSD-LOGMAG	PSD-LOGMAG(C1)	Logarithmic amplitude of the power spectrum density of a specified waveform
CS-REAL	CS-REAL(C1,C2)	Real part of the cross spectrum of two specified waveforms
CS-IMAG	CS-IMAG(C1,C2)	Imaginary part of the cross spectrum of two specified waveforms
CS-MAG	CS-MAG(C1,C2)	Amplitude of the cross spectrum of two specified waveforms
CS-LOGMAG	CS-LOGMAG(C1,C2)	Logarithmic amplitude of the cross spectrum of two specified waveforms
CS-PHASE	CS-PHASE(C1,C2)	Phase of the cross spectrum of two specified waveforms
TF-REAL	TF-REAL(C1,C2)	Real part of the transfer function of two specified waveforms
TF-IMAG	TF-IMAG(C1,C2)	Imaginary part of the transfer function of two specified waveforms
TF-MAG	TF-MAG(C1,C2)	Amplitude of the transfer function of two specified waveforms
TF-LOGMAG	TF-LOGMAG(C1,C2)	Logarithmic amplitude of the transfer function of two specified waveforms
TF-PHASE	TF-PHASE(C1,C2)	Phase of the transfer function of two specified waveforms
CH-MAG	CH-MAG(C1,C2)	Amplitude of the coherence function of two specified waveforms

Settings for FFT

- **Points** (number of points used for computation):
Select 100 points, 200 points, 500 points, 1000 points, 2000 points, 5000 points, 10000 points, 20000 points, 50000 points, 100000 points, 200000 points, 500000 points, 1000000 points, or 2000000 points.

Note

Executing an FFT calculation with 1000000 points or more, only M1 is calculated and the result is displayed.

- **FFT start point:**
When the number of loaded points is less than 10M: Specify 0 to “Number of loaded points - no. of FFT computation points”
When larger than 10M: set between computation start point and “computation start point + 10M - no. of FFT points”
- **Window** (time window):
Select the Rect (rectangle), Hanning (hanning), or FlatTop (flat-top) window.

Displaying the FFT Range

The FFT range is indicated with a green bar on the main waveform display window and the zoomed waveform display window.

Drag the bar to move the computation range.

If FFT cannot be performed, the bar indicating the range and the word “FFT” turn red.

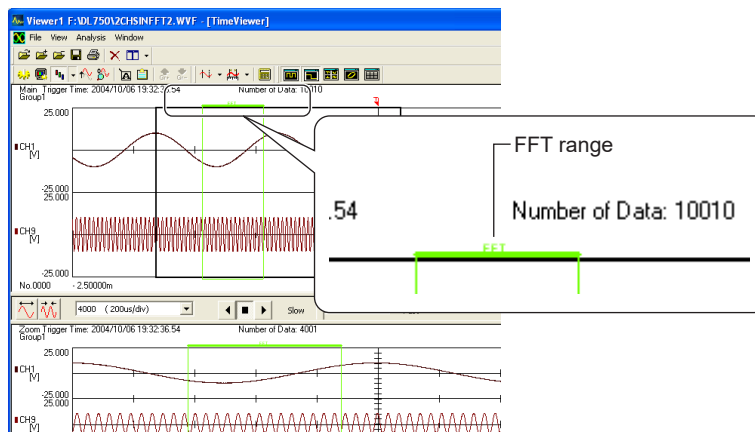

Icon displayed during measurement through computation

While measurement through computation is being performed, the icon shown below appears in the status bar.

 : Computing (blinks on and off)

 : Accessing file

Note

- **Canceling computation**
During computation, a cancel button and a progress bar are displayed in the status bar. Click the Cancel button to cancel the computation.
If you cancel the computation, nothing will be displayed in the waveform display window and measurement result window.



Computational accuracy

Single-precision floating-point type

Details of Various Computations

Phase Shift (SHIFT)

Shifts the phase of the specified waveform. Set the amount of shift as follows.

SHIFT(C1,N)

N: Integrated value for the number of data points to the time axis

RMS Value (RMS)

Calculates the RMS value of the waveform that has been assigned.

$$\sqrt{\frac{1}{N} \sum_{n=1}^N s(n)^2}$$

s: Sampling data

N: Integrated value for the number of data points to the time axis

In the expression, set the target trace number and time.

Expression: RMS(C1,T)

T: Computation time (ms)

T = (N/sample rate)×1000

Filter (FILT1/FILT2)

Type

Type	Bandwidth
Gauss	Lowpass
Sharp	Lowpass/Highpass/Bandpass
IIR (Butterworth)	Lowpass/Highpass/Bandpass

Filter Orders

See the following table for the filter orders.

Cutoff frequency/sampling frequency × 100		2%	5%	10%	20%	30%
Gauss	Lowpass	49	21	9	5	5
Sharp	Lowpass	88	36	18	9	8
	Highpass	159	65	33	17	13
IIR	Lowpass	4	4	4	3	2
	Highpass	4	4	4	4	3

Note

- You can set the cutoff frequency in the range from 2 to 30% of the sampling frequency (in 0.2% steps).
- The higher the filter order, the longer computation takes.

Filter Characteristics

Filter	Pass band Ripple	Attenuation slope	Attenuation in the Stop band	Phase
Gauss	0 dB	*	–	Linear
Sharp	±0.3 dB	–40 dB at 1 oct (Lowpass),	–40 dB	Linear
		–40 dB at –1 oct (Highpass)		
IIR	0 dB	–5 dB at 1/6 oct (Lowpass),	–	Non-linear
		–20 dB at –1 oct (Highpass)		

* Attenuation for a Gauss filter is $-3.0 \times (f/f_c)^2$ dB (where f is the frequency and f_c is the cutoff frequency).

Examples of Frequency Characteristics for Various Filters

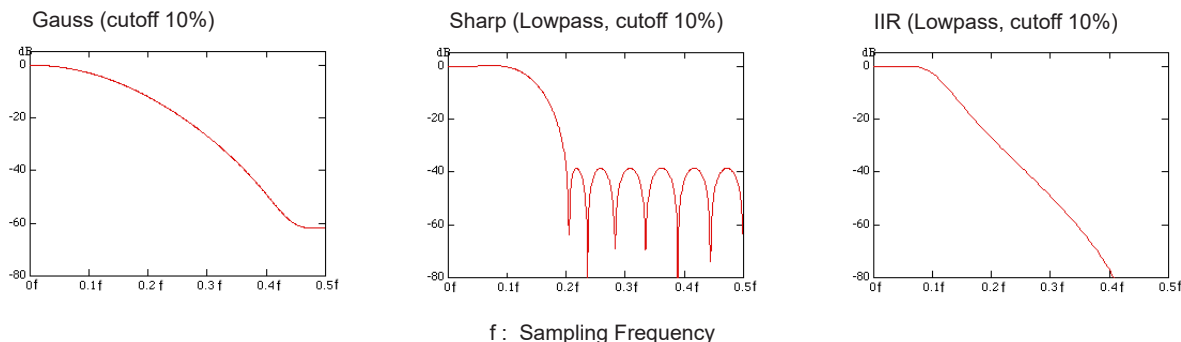

Hilbert Function (HLBT)

Normally, when we analyze a real time signal, it is convenient to think of the signal as the real part of a complex valued signal. Analysis is often more convenient when done using the complex signal. Given that the real time signal is considered to be the real part of the complex signal, the imaginary part is then equal to the Hilbert transform of the real part. When performing a Hilbert transform on a signal in the time domain, the signal is first transformed into the frequency domain using the Fourier transform. Next, the phase of each frequency component is shifted by -90 degrees if the frequency is positive and $+90$ degrees if negative. Lastly, the Hilbert transform is completed by taking the inverse Fourier transform. As can be seen from the above description, the Hilbert transform does not change the order of the individual variables. The Hilbert transform of a time signal results in another time signal.

Application Example

The Hilbert transform can be used to analyze an envelope waveform.
 AM (amplitude modulation): $SQRT(C1*C1+HLBT(C1)*HLBT(C1))$
 Demodulation of a FM signal: $DIF(PH(C1, HLBT(C1)))$

Phase Function (PH)

Phase function $PH(C1, C2)$ computes $\tan^{-1}(C1/C2)$. However, the phase function takes the phase of the previous point into consideration and continues to sum even when the value exceeds $\pm\pi$ (The ATAN function reflects at $\pm\pi$). The unit is radians.

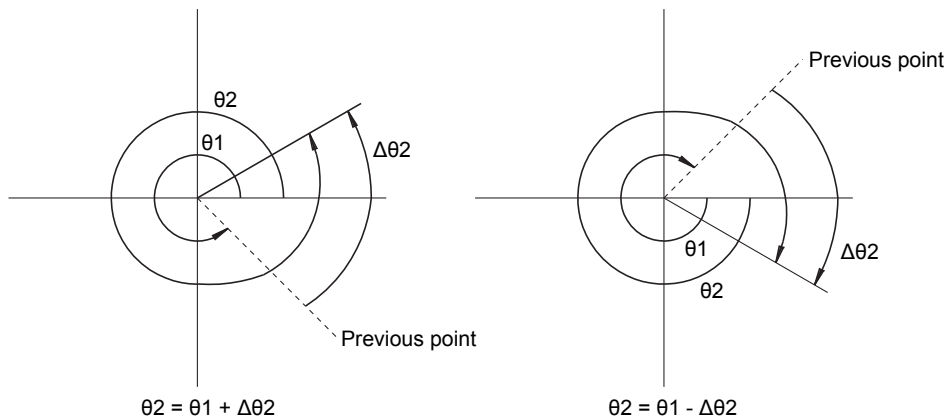

4.6 Analyzing Waveforms by Computations (Math Edition)

Binary Conversion (BIN)

Performs binary conversion with respect to the specified threshold level.

The threshold level is specified as follows:

A and B represent the Upper and Lower threshold levels, respectively.

$BIN(C1, A, B)$

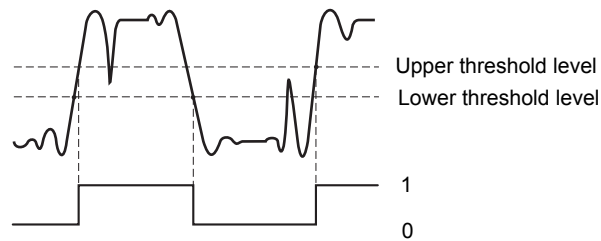

Pulse Width Computation (PWHH/PWHL/PWLH/PWLL/PWXX)

The signal is converted into binary values by comparing to a preset threshold level, and the time of the pulse width is plotted as the Y-axis value for that interval.

The following 4 intervals are available:

PWHH: From the rising edge to the next rising edge.

PWHL: From the rising edge to the next falling edge.

PWLH: From the falling edge to the next rising edge.

PWLL: From the falling edge to the next falling edge.

PWXX: From the rising or falling edge to the next rising or falling edge.

The threshold level is specified as follows:

A and B represent the Upper and Lower threshold levels, respectively.

$PWHH(C1, A, B)$

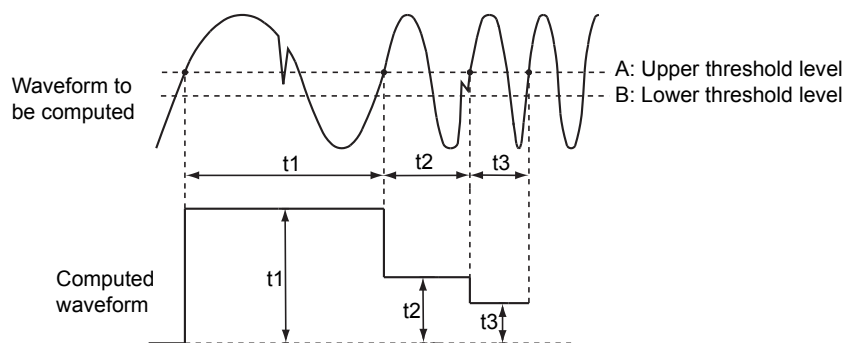

FFT**Linear Spectrum (LS-REAL/LS-IMAG/LS-MAG/LS-LOGMAG/LS-PHASE)**

The linear spectrum is directly determined by the FFT. The power spectrum and cross spectrum can be determined from one or two linear spectra.

The FFT is a complex function, and thus the linear spectrum is composed of both a real and an imaginary part. The magnitude and phase of the frequency components of the measured waveform can be derived from the real and imaginary parts of the FFT result. The following spectra can be determined:

Item	Expression	Computation
Real part	LS-REAL	R
Imaginary part	LS-IMAG	I
Magnitude	LS-MAG	$\sqrt{(R^2 + I^2)}$
Log magnitude	LS-LOGMAG	$20 \times \log\sqrt{(R^2 + I^2)}$
Phase	LS-PHASE	$\tan^{-1}(I/R)$

Log magnitude reference (0 dB): 1 V_{peak}

R, I: R and I represent the real part and the imaginary part, respectively, when each frequency component G of a linear spectrum is represented by "R + jI."

Rms Value Spectrum (RS-MAG/RS-LOGMAG)

Rms value spectrum expresses the rms value of the magnitude of the linear spectrum. It does not contain phase information.

The following spectra can be determined:

Item	Expression	Computation
Magnitude	RS-MAG	$\sqrt{(R^2 + I^2)}/2$
Log magnitude	RS-LOGMAG	$20 \times \log\sqrt{(R^2 + I^2)}/2$

Log magnitude reference (0 dB): 1 V_{rms}

Power Spectrum (PS-MAG/PS-LOGMAG/PSD-MAG/PSD-LOGMAG)

The power spectrum expresses the power of each frequency component included in the measured signal. It is determined by taking the product of the linear spectrum and its complex conjugate. It does not contain phase information.

The following spectra can be determined:

Item	Expression	Computation	
Amplitude	PS-MAG	DC component	$R^2 + I^2$
		AC component	$(R^2 + I^2)/2$
Log magnitude	LS-MAG	DC component	$10 \times \log(R^2 + I^2)$
		AC component	$10 \times \log\{(R^2 + I^2)/2\}$

Log magnitude reference (0 dB): 1 V_{rms}²

Power Spectral Density (PSD-MAG/PSD-LOGMAG)

The power spectral density (PSD) expresses the power spectrum per unit frequency. It is determined by dividing the power spectrum by the frequency resolution Δf found during the analysis of the power spectrum. The results of the PSD computation vary depending on the window function chosen. The power spectral density is used to compare power spectra analyzed at different frequency bands. However, it is not necessary for signals having a line spectrum such as a sine wave.

The following spectra can be determined:

Item	Expression	Computation
Magnitude	PSD-MAG	PS-MAG/ Δf (for rectangular window)
		PS-MAG/ $1.5\Delta f$ (for Hanning window)
Log magnitude	PSD-LOGMAG	$10 \times \log$ PS-MAG/ Δf (for rectangular window)
		$10 \times \log$ PS-MAG/ $1.5\Delta f$ (for Hanning window)

Log magnitude reference (0 dB): 1 V_{rms}²

4.6 Analyzing Waveforms by Computations (Math Edition)

Cross Spectrum (CS-REAL/CS-IMAG/CS-MAG/CS-LOGMAG/CS-PHASE)

The cross spectrum is determined from 2 signals. It is found by taking the product of the linear spectrum of one signal (G_x) and the complex conjugate (G_x^*) of the linear spectrum of the other signal (G_y).

If the linear spectra of the 2 signals are represented by

$$G_x = R_x + jI_x$$

$$G_y = R_y + jI_y$$

then the cross spectrum G_{yx} is

$$G_{yx} = G_y \times G_x^*$$

$$= (R_y + jI_y)(R_x - jI_x) = R_{yx} + jI_{yx}$$

where $R_{yx} = R_yR_x + I_yI_x$

$$I_{yx} = R_xI_y - R_yI_x$$

The following spectra can be determined:

Item	Expression	Computation	
Real part	CS-REAL	DC component	R_{yx}
		AC component	$R_{yx}/2$
Imaginary part	CS-IMAG	DC component	I_{yx}
		AC component	$I_{yx}/2$
Amplitude	CS-MAG	DC component	$\sqrt{(R_{yx}^2 + I_{yx}^2)}$
		AC component	$\sqrt{(R_{yx}^2 + I_{yx}^2)}/2$
Log magnitude	CS-LOGMAG	DC component	$10 \times \log\sqrt{(R_{yx}^2 + I_{yx}^2)}$
		AC component	$10 \times \log\sqrt{(R_{yx}^2 + I_{yx}^2)}/2$
Phase	CS-PHASE	–	$\tan^{-1}(I_{yx}/R_{yx})$

Transfer Function (TF-REAL/TF-IMAG/TF-MAG/TF-LOGMAG/TF-PHASE)

The transfer function expresses the frequency characteristics between the input and the output of a system. The transfer function is given by the ratio of the linear spectrum of the output (G_y) to the spectrum of the input (G_x) at each frequency. Also, as can be seen from the equation below, the transfer function can be defined as the ratio of the cross spectrum of the input and output (G_{yx}) and the input power spectrum (G_{xx}).

$$\text{Transfer Function} = G_y/G_x = (G_y \times G_x^*)/(G_x \times G_x^*) = G_{yx}/G_{xx} = (R_{yx} + jI_{yx})/(R_x^2 + I_x^2)$$

The following items can be determined:

Item	Expression	Computation
Real part	TF-REAL	$R_{yx}/(R_x^2 + I_x^2)$
Imaginary part	TF-IMAG	$I_{yx}/(R_x^2 + I_x^2)$
Magnitude	TF-MAG	$\sqrt{(R_{yx}^2 + I_{yx}^2)}/(R_x^2 + I_x^2)$
Log magnitude	TF-LOGMAG	$20 \times \log\sqrt{(R_{yx}^2 + I_{yx}^2)}/(R_x^2 + I_x^2)$
Phase	TF-PHASE	$\tan^{-1}(I_{yx}/R_{yx})$

The magnitude of the transfer function gives the ratio of the magnitudes of the linear spectra of the output and input, whereas phase of the transfer function gives the phase difference between the two.

Coherence Function (CH-MAG)

This function expresses the ratio of the output power generated by the input to the system to the total output power.

$$\text{Coherence function} = G_{yx} \times G_{yx}^* / (G_{xx} \times G_{yy})$$

Item	Expression	Computation
Magnitude	CH-MAG	$(R_{yx2} + I_{yx2}) / (G_{xx} \times G_{yy})$

If the output signal is due entirely to the input signal, the coherence function becomes 1. As the ratio decreases, it falls below 1. Thus, the coherence function always takes on a value between 0 and 1.

Note

- On one data acquisition, the coherence function becomes 1 across all frequencies.
- The computed waveform must be averaged.

Number of FFT Computed Points

You can select 100 points, 200 points, 500 points, 1000 points, 2000 points, 5000 points, 10000 points, 20000 points, 50000 points, 100000 points, 200000 points, 500000 points, 1000000 points, or 2000000 points.

About Time Windows

You can select rectangular, Hanning, or flattop as the time window.

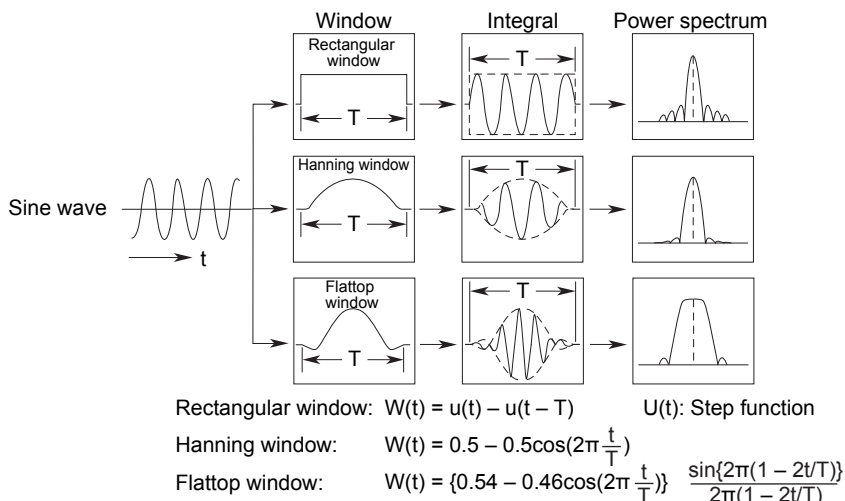

The rectangular window is best suited to transient signals, such as an impulse wave, that attenuate completely within the time window. The Hanning window allows continuity of the signal by gradually attenuating the parts of the signal located near the ends of the time window down to the "0" level. Hence, it is best suited to continuous signals. The frequency resolution of the Hanning window is higher compared with the Flattop window. However, the flattop window has a higher level of accuracy of the spectrum. When the waveform being analyzed is a continuous signal, consider the above characteristics when selecting the proper window to use.



4.7 Inserting Annotations in the Waveform View

Procedure

Inserting Annotations

1. Click , , or click **View > Add Annotation** and select Annotation Type. There are eight types of annotations: text, DeltaT, DeltaV, marker, Delta marker, waveform parameter, history statistics, and cycle statistics. The pointer icon displayed in the tool bar or waveform view changes according to the selected annotation. For details, see the explanation starting on the next page.
2. Insert the annotation using the appropriate procedure for the selected annotation. For details, see the explanation starting on the next page. When selecting an annotation of a particular type while in Annotation mode, if you click a different type of annotation that was previously inserted, the selected annotation changes to the clicked type. Select the type of annotation

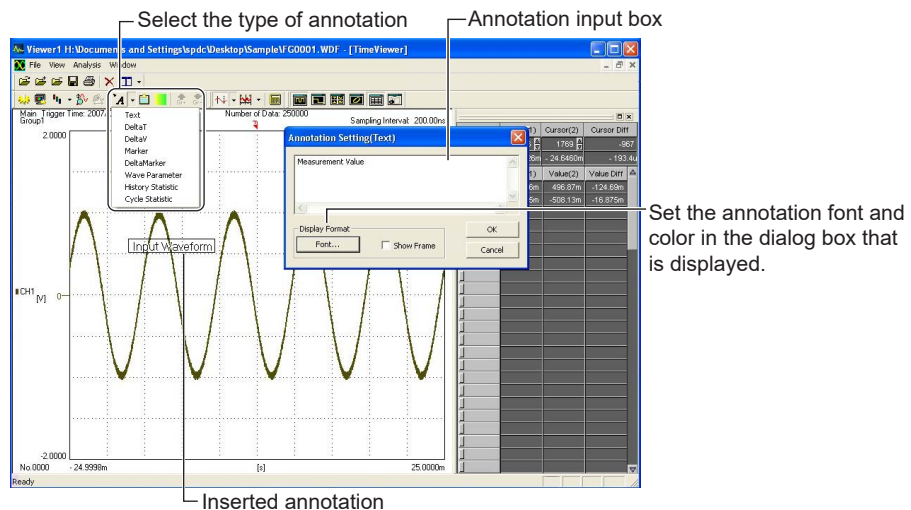

Set the annotation font and color in the dialog box that is displayed.

Inserting Annotations Using the (Right-Click) Shortcut Menu

When in Annotation mode, a shortcut menu is displayed when any of the following operations is carried out. Click New and then the type of annotation to insert the annotation in the screen.

- **Right-click in the waveform display**

Right-click to display the shortcut menu.

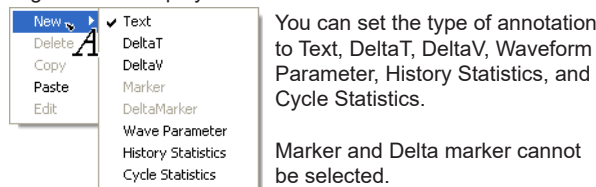

- **Right-click a waveform**

If you place the pointer on the waveform, the information for that point is displayed.

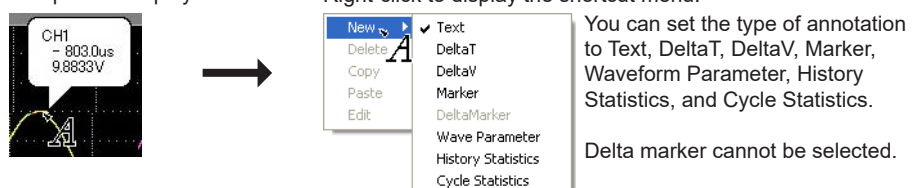

Copying and Pasting Annotations

Click to select the annotation to copy, then right-click to display the same shortcut menu mentioned on the previous page. Select **Copy**. Right-click the location onto which you wish to paste the annotation, then select **Paste** in the shortcut menu that is displayed.

Editing Annotations

Click to select the annotation to edit, then right-click to display the same shortcut menu mentioned on the previous page. Select **Edit**. A dialog box corresponding to the selected annotation is displayed. Edit the annotation, then click **OK** or **Apply**.

Deleting Annotations

To delete annotations, click **View > Delete Annotation > Selected Item** or **All Items**.

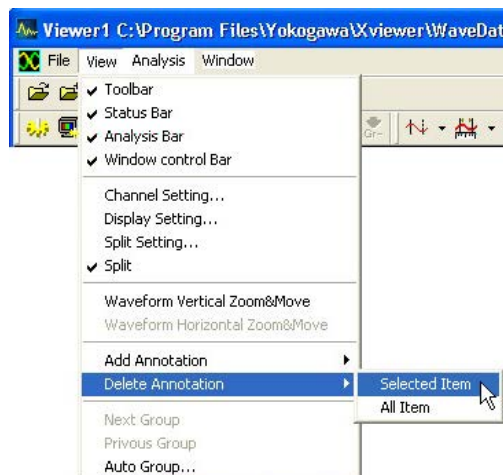

You can also click to select an annotation you wish to delete and press the **Delete** key. Or, you can click to select the annotation to delete, right-click to display the same shortcut menu mentioned on the previous page, and then select **Delete**.

Explanation

Annotation Types

There are eight types of annotations: text, DeltaT, DeltaV, marker, Delta marker, waveform parameter, history statistics, and cycle statistics.

• Linked Annotations

- DeltaT, DeltaV, marker, Delta marker, waveform parameter, history statistics, and cycle statistics are annotations that are linked to waveforms.
- If the text annotations is linked to a waveform, they are connected by link lines.
- You can insert annotations into individual waveforms. Links to each waveform are preserved even if you switch the displayed group.

• Non-Linked Annotations

Text annotations without link lines are non-linked annotations. Their positions change relative to the size of the screen.

Example of a Text Annotation

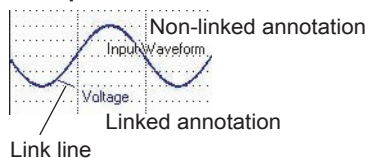

4.7 Inserting Annotations in the Waveform View

Annotation-Compatible Windows

- Text, DeltaT, and DeltaV annotations can be inserted into the main waveform display window, zoom waveform display window, and XY waveform display window.
- Marker, delta marker, waveform parameter, history statistics, and cycle statistics annotations can be inserted into the main waveform display window and zoom waveform display window.
- Only text annotation can be inserted into logic waveforms.

Note

In the following situations, annotations cannot be inserted in the zoom waveform display window.

- When the waveform shown in the main waveform display window and that shown in the zoom waveform display window are different (when “Share channel setting in Main/Zoom” is set to off).
- When waveforms are overlaid, the active waveform in the main waveform display window and that in the zoom waveform display window are different.

Text Pointer Icon:

If you select a text annotation and double-click in the waveform view or on a waveform, the following settings dialog box is displayed. You can set the annotation display format. If you double-clicked on the waveform, a waveform-linked annotation is inserted.

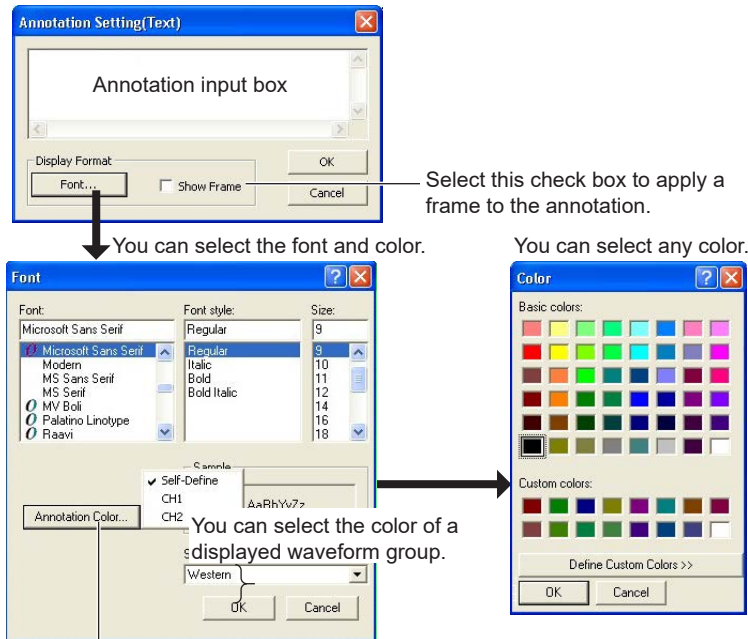

Display Example

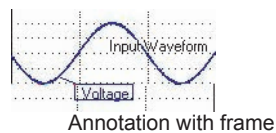

Changing the Character Size

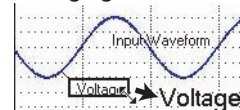

When you select an annotation, a frame appears. Drag one of the four corners of the frame.

Moving an Annotation

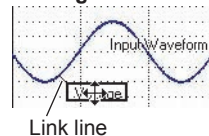

Select the annotation, then drag it. If a link line flows outside of the waveform view when zooming or changing the scale, the link line disappears.

DeltaT Pointer Icon: 

When you select a DeltaT annotation and perform procedure a or b below in the waveform view, the X axis value is displayed.

a. Drag horizontally.

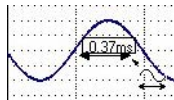

b. Double-click to display the dialog box below. You can set the trace (waveform) to which the annotation is linked, the display format, the arrow style, and other items. The measurement range of the new X axis value displayed when you double-click is 2 div.

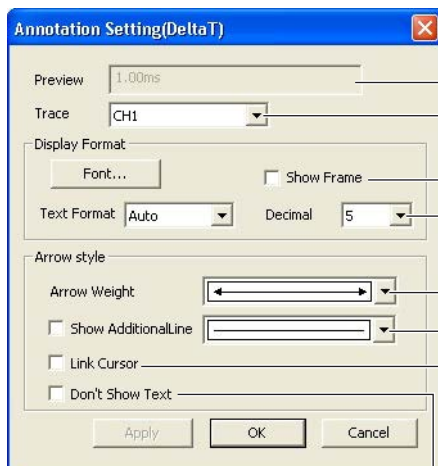

Preview of the value to be displayed (cannot be entered).

Select the trace (waveform) to which to link the annotation.

Set the font and frame (see page 4-32).

Set the text format and decimal places (see section 3.2, but note that "Exponential" is not one of the choices).

Select the arrow thickness.

Draw an additional line through the tip of the arrow. Also select the thickness of the additional line.

Shows a DeltaT annotation spanning vertical cursors.

The value is not displayed.

Display Examples

DeltaT annotation with additional line

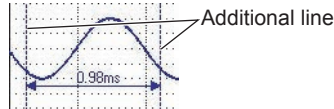

DeltaT annotation spanning vertical cursors

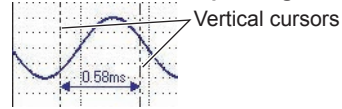

Moving a DeltaT annotation

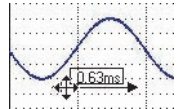

Select an arrow, then drag it. To move just the value, use the same procedure as for moving a text annotation.

Resizing arrows

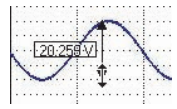

Select the tip of the arrow, then drag it. The value is updated according to the length of the arrow.

If the arrow flows outside of the waveform view

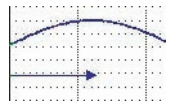

If an arrow flows outside of the waveform view when zooming or changing the scale, the value is not displayed.

Changing the character size

Same procedure as for text annotations.

4.7 Inserting Annotations in the Waveform View

DeltaV Pointer Icon:

When you select a DeltaV annotation and perform procedure a or b below in the waveform view, the Y axis value is displayed.

a. Drag vertically.

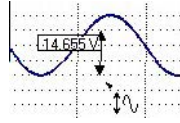

b. Double-click to display the dialog box below. You can set the trace (waveform) to which the annotation is linked, the display format, the arrow style, and other items. The measurement range of the new Y axis value displayed when you double-click is 2 div.

Annotation Setting(DeltaV)

Preview: 10.000 V

Trace: CH1

Display Format:
 Show Frame

Text Format: Auto Decimal: 5

Arrow style:
 Arrow Weight:
 Show AdditionalLine
 Link Cursor
 Don't Show Text

Preview of the value to be displayed (cannot be entered).

Select the trace (waveform) to which to link the annotation.

Set the font and frame (see page 4-32).

Set the text format and decimal places (see section 3.2).

Select the arrow thickness.

Draw an additional line through the tip of the arrow. Also select the thickness of the additional line.

Shows a DeltaV annotation spanning horizontal cursors.

The value is not displayed.

Display Examples

DeltaV annotation with additional line

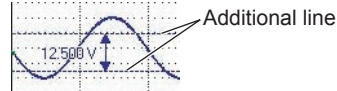

DeltaV annotation spanning horizontal cursors

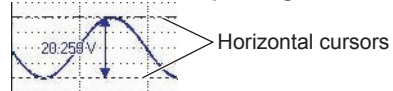

Moving a DeltaV

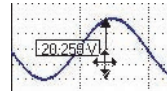

Select an arrow, then drag it. To move just the value, use the same procedure as for moving a text annotation.

Resizing arrows

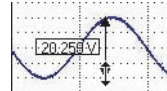

Select the tip of the arrow, then drag it. The value is updated according to the length of the arrow.

When zooming the waveform vertically

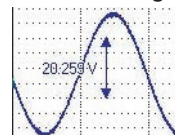

The length of the arrow does not change even when zoomed. The value is updated according to the zoom ratio.

Changing the character size

Same procedure as for text annotations.

Markers Pointer Icon: 

With marker annotations, the trace, X axis value, and Y axis value at the double-clicked point are displayed. If you select a marker annotation and double-click the waveform, the settings dialog box below is displayed.

- You can set the trace (waveform) to which the annotation is linked, the format, the marker style, and other items.
- There are four marker styles. Each time you insert a marker annotation, a new style is used.

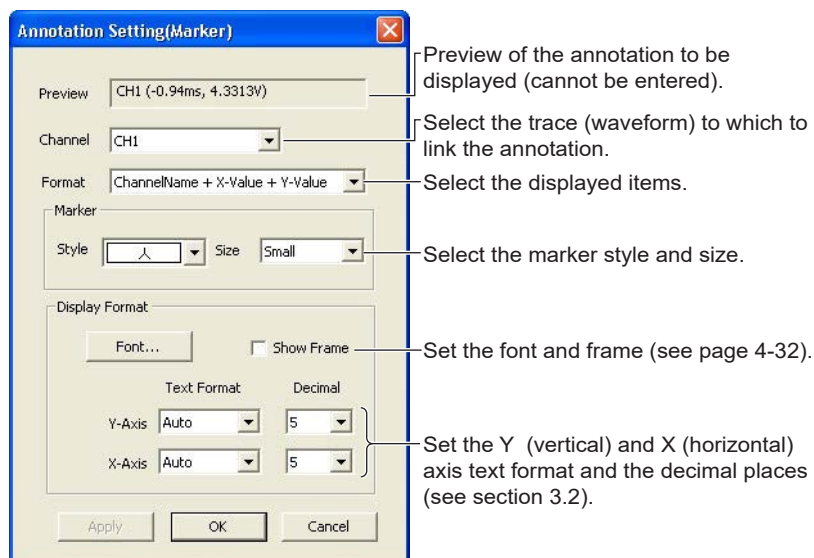
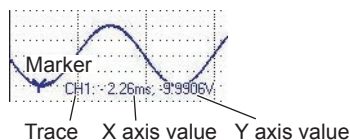
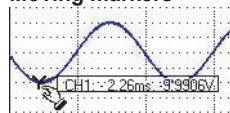
**Display Examples****Moving markers**

Select the marker, then drag it. Only the marker moves. The value is updated according to the new marker location.

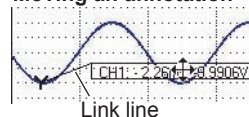
Moving an annotation

Select the annotation, then drag it. Only the annotation moves. If a link line flows outside of the waveform view when zooming or changing the scale, the link line disappears.

Changing the character size

Same procedure as for text annotations.

4.7 Inserting Annotations in the Waveform View

Delta Marker Pointer Icon:

With Delta marker annotations, the DeltaT annotation (X axis value) and DeltaV annotation (Y axis value) are displayed between two markers.

- Select the Delta marker annotation, then drag starting from any one point on the waveform to any other point on the waveform. A DeltaT annotation and DeltaV annotation appear between the two markers.
- If a Delta marker is placed between two different traces, only the Delta T annotation is displayed.

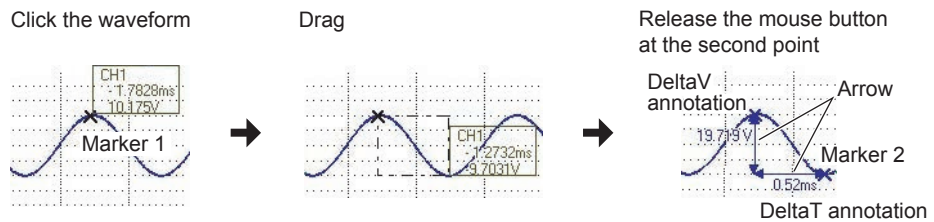

Double-click on an annotation to display the settings dialog box below.

- The target trace (waveform), marker style, and other items relating to markers can be set.
- There are four marker styles. Each time you insert a marker annotation, a new style is used.
- You can set the display format, arrow style, and other items relating to DeltaT and DeltaV annotations. Click the DeltaT or DeltaV tab to display the corresponding settings.

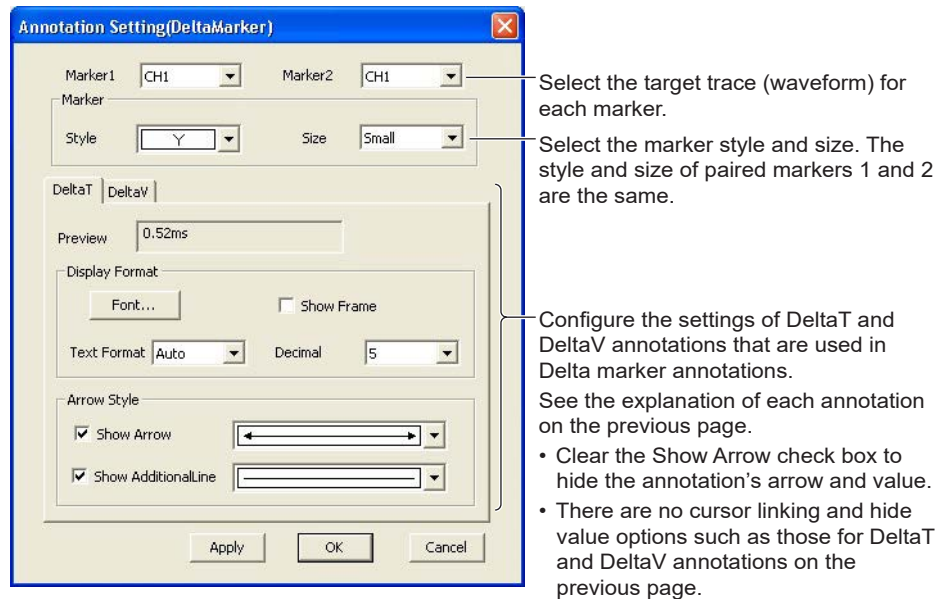

Display Examples

Delta marker annotation with additional line

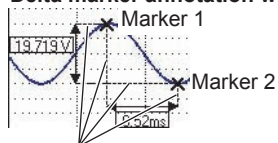

Additional line

Moving markers

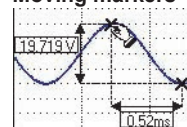

Select the marker, then drag it. The arrow length, value, and additional line are updated according to the new marker location.

Moving a DeltaT

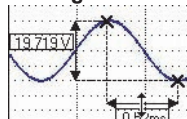

Select the arrow of the DeltaT annotation, then drag it. To move just the value, use the same procedure as for moving a text annotation.

Resizing arrows (DeltaT annotation only)

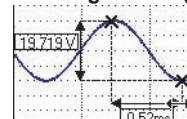

Select the tip of the arrow, then drag it. The marker is moved and the value is updated according to the length of the arrow.

Moving a DeltaV

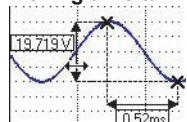

Select the arrow of the DeltaV annotation, then drag it. To move just the value, use the same procedure as for moving a text annotation.

If the arrow flows outside of the waveform view

With Delta marker annotations, if a DeltaT or DeltaV annotation arrow flows outside of the waveform view when zooming or changing the scale, the value is not displayed.

Changing the character size

Same procedure as for text annotations.

4.7 Inserting Annotations in the Waveform View

Waveform Parameters Pointer Icon:

When you select a waveform annotation and perform procedure a or b below in the waveform view, the measured value of the waveform parameter is displayed.

a. Drag horizontally.

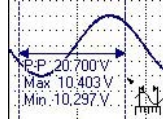

b. Double-click to display the dialog box below. You can set the measured items, the trace (waveform) to which the annotation is linked, the display format, the arrow style, and other items.

The measurement range of the new waveform parameter displayed when you double click is 2 div.

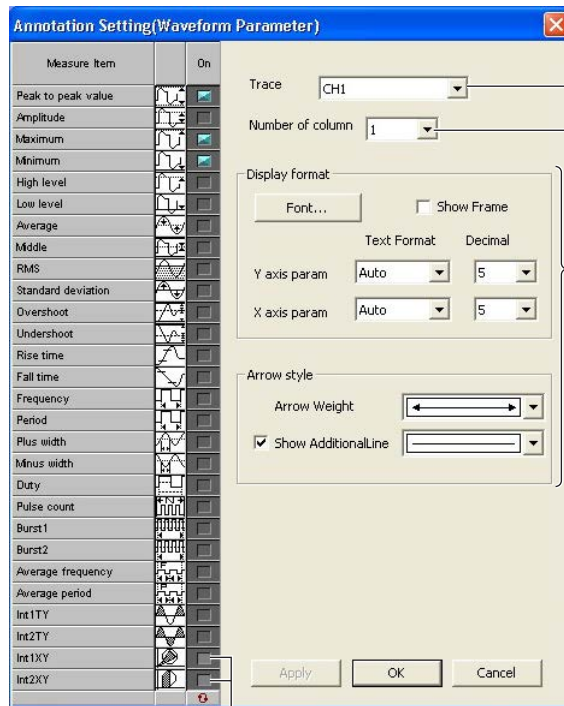

Select the trace (waveform) to which to link the annotation.

Select the number of horizontally-displayed items (columns).

Configure the settings of fonts and arrows that are used in waveform parameter annotations.

See the explanation of the DeltaT and DeltaV annotations on the previous page.

- Under Vertical axis parameters, set the vertical axis waveform parameter text format and decimal places. Under Horizontal axis parameters, set the horizontal axis waveform parameter text format and decimal places.
- There are no cursor linking and hide value options such as those for DeltaT and DeltaV annotations.

Measurement items Int1XY and Int2XY cannot be selected.

Display Examples

Waveform parameter annotation with additional line

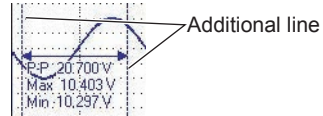

Resizing arrows

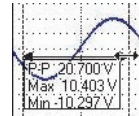

Select the tip of the arrow, then drag it. The value is updated according to the length of the arrow.

Moving a waveform parameter annotation

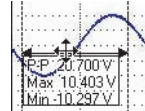

Select the arrow of a waveform parameter annotation, then drag it. To move just the value, use the same procedure as for moving a text annotation.

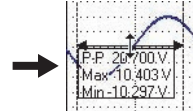

As you begin to move it vertically, the mark indicating the direction of motion becomes \updownarrow .

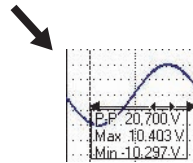

As you begin to move it horizontally, the mark indicating the direction of motion becomes \leftrightarrow . The value is updated according to the measurement range of the new location.

If the arrow flows outside of the waveform view

If an arrow flows outside of the waveform view when zooming or changing the scale, the value is not displayed.

Changing the character size

Same procedure as for text annotations.

Note

If you click an annotation inserted with the annotation insertion pointer, the annotation turns white, and the distal line, mesial line, and proximal line are displayed in the annotation area. You can move the distal line, mesial line, and proximal line to change their values.

4.7 Inserting Annotations in the Waveform View

History Statistic Pointer Icon:

When you select a history statistic annotation and perform procedure a or b below in the waveform view, the measured value of the history statistics is displayed.

a. Drag horizontally.

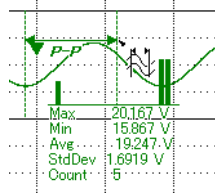

b. Double-click to display the dialog box below. You can set the measurement items, the trace (waveform) to which the annotation is linked, the display format, the arrow style, and other items. The measurement range of the new history statistics displayed when you double-click is 2 div.

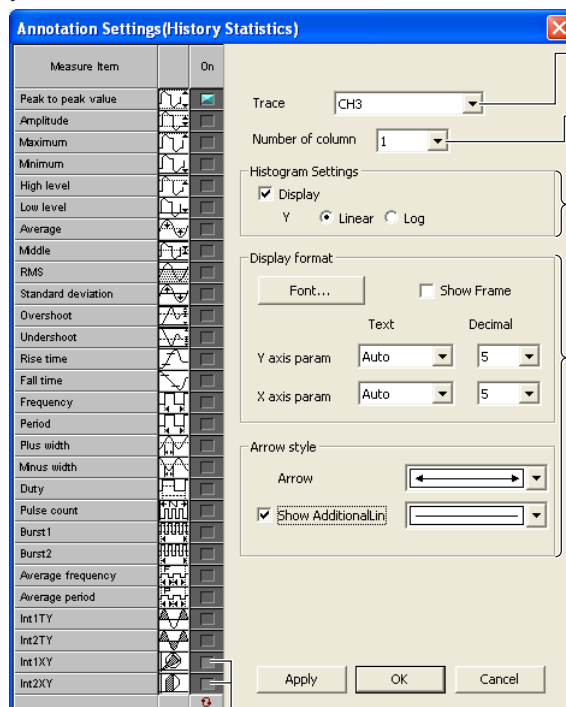

Measurement items Int1XY and Int2XY cannot be selected.

Select the trace (waveform) to which to link the annotation.

Select the number of horizontally-displayed items (columns).

Select the check box to display histograms in annotations.

Select whether to display the histogram's Y axis using a linear or logarithmic scale.

Configure the settings of fonts and arrows that are used in history statistic annotations

See the descriptions of the DeltaT and DeltaV annotations on the previous page.

- Use the boxes next to Y axis param to set the text format and the number of decimal places for the vertical axis. Use the boxes next to X axis param to set the text format and the number of decimal places for the horizontal axis.
- There are no Link Cursor and Don't Show Text options, which are available for DeltaT and DeltaV annotations.

Display Example

History statistic annotation with additional lines

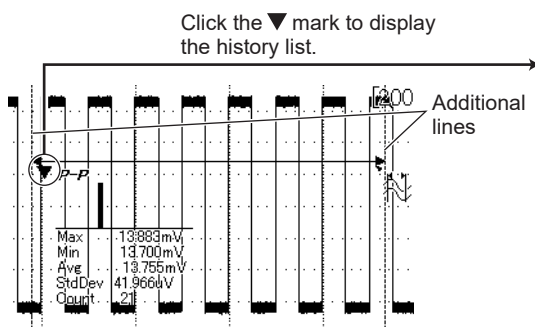

History No.	P-P	Amp	Max
0000	13.808mV↑	13.279mV↑	7.0083m
0001	13.775mV	13.275mV	6.9958m
0002	13.738mV	13.275mV	6.9958m
0003	13.788mV	13.271mV	7.0083m
0004	13.804mV	13.267mV	7.0250m
0005	13.717mV	13.262mV	6.9708m
0006	13.738mV	13.262mV	6.9875m
0007	13.729mV	13.258mV	6.9958m
0008	13.779mV	13.254mV	7.0000m
0009	13.713mV	13.254mV	6.9625m
0010	13.771mV	13.254mV	6.9958m
0011	13.679mV↓	13.254mV	6.9500m
0012	13.700mV	13.246mV	6.9750m
0013	13.700mV	13.246mV	6.9625m
0014	13.800mV	13.246mV	7.0292m

Resizing Arrows and Moving History Statistic Annotations

The procedure for resizing arrows and moving annotations are the same as for waveform parameter annotations.

If the arrow flows outside of the waveform view

If an arrow flows outside of the waveform view when zooming or changing the scale, the value is not displayed.

Changing the character size

Same procedure as for text annotations

Note

- Canceling Annotation mode

In Annotation mode, a cancel button and a progress bar are displayed in the status bar.

Click the Cancel button to cancel Annotation mode.

If you cancel Annotation mode, the waveform display window only shows an arrow that indicates the annotation range and not the values.

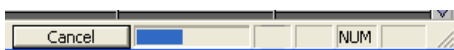

- If you click an annotation inserted with the annotation insertion pointer, the annotation turns white, and the distal line, mesial line, and proximal line are displayed in the annotation area. You can move the distal line, mesial line, and proximal line to change their values.

4.7 Inserting Annotations in the Waveform View

Cycle Statistic Pointer Icon:

When you select a cycle statistic annotation and perform procedure a or b below in the waveform view, the measured value of the cycle statistics is displayed.

a. Drag horizontally.

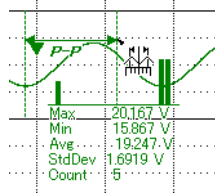

b. Double-click to display the dialog box below. You can set the measured items, the trace (waveform) to which the annotation is linked, the display format, the arrow style, and other items. The measurement range of the new cycle statistics displayed when you double-click is 2 div.

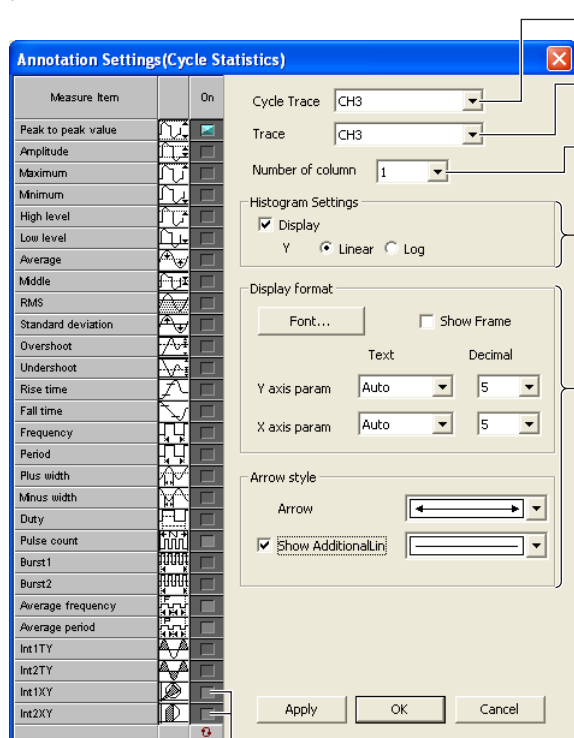

Select the reference trace for cycle statistic measurements.

Select the trace (waveform) to which to link the annotation.

Select the number of horizontally-displayed items (columns).

Select the check box to display histograms in annotations.

Select whether to display the histogram's Y axis using a linear or logarithmic scale.

Configure the settings of fonts and arrows that are used in cycle statistic annotations

See the descriptions of the DeltaT and DeltaV annotations on the previous page.

- Use the boxes next to Y axis param to set the text format and the number of decimal places for the vertical axis. Use the boxes next to X axis param to set the text format and the number of decimal places for the horizontal axis.
- There are no Link Cursor and Don't Show Text options, which are available for DeltaT and DeltaV annotations.

Measurement items Int1XY and Int2XY cannot be selected.

Display Example

Cycle statistic annotation with additional lines

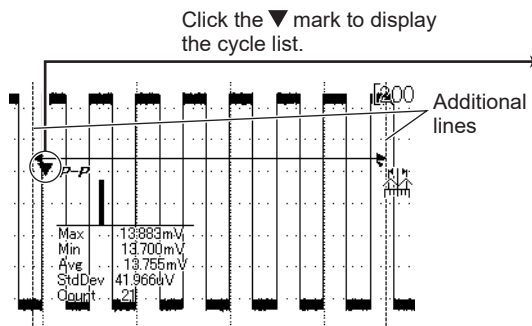

Cycle No.	P-P	Amp	Max
0000	13.846mV	13.287mV↑	8.9125mV↓
0001	13.850mV	13.283mV	8.9333mV
0002	13.854mV	13.287mV	8.9208mV
0003	13.871mV	13.279mV	8.9500mV
0004	13.833mV↓	13.279mV	8.9500mV
0005	13.887mV	13.279mV	8.9542mV
0006	13.754mV↑	13.283mV	8.9542mV
0007	13.879mV	13.283mV	8.9708mV
0008	13.892mV	13.275mV↓	8.9292mV
0009	13.887mV	13.279mV	8.9875mV↑
0010	13.700mV	13.279mV	8.9333mV

Resizing Arrows and Moving Cycle Statistic Annotations

The procedure for resizing arrows and moving annotations are the same as for waveform parameter annotations.

If the arrow flows outside of the waveform view

If an arrow flows outside of the waveform view when zooming or changing the scale, the value is not displayed.

Changing the character size

Same procedure as for text annotations

Note

- Canceling Annotation mode

In Annotation mode, a cancel button and a progress bar are displayed in the status bar.

Click the Cancel button to cancel Annotation mode.

If you cancel Annotation mode, the waveform display window only shows an arrow that indicates the annotation range and not the values.

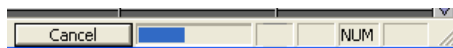

- If you click an annotation inserted with the annotation insertion pointer, the annotation turns white, and the distal line, mesial line, and proximal line are displayed in the annotation area. You can move the distal line, mesial line, and proximal line to change their values.

Copying and Pasting Annotations

Place the pointer on an annotation or window and right-click to carry out the following operations.

Operation	When pointing to an annotation	When pointing on the window
New	No	Yes
Delete	Yes	No
Copy	Yes	No
Paste	No	Yes
Edit	Yes	No

4.8 Transferring a Waveform View to the Clipboard

Procedure

Transferring a Waveform View to the Clipboard

Click  to transfer the viewer window you are viewing as image data to the clipboard. You can see the image by executing a paste command in an application that can handle image data.

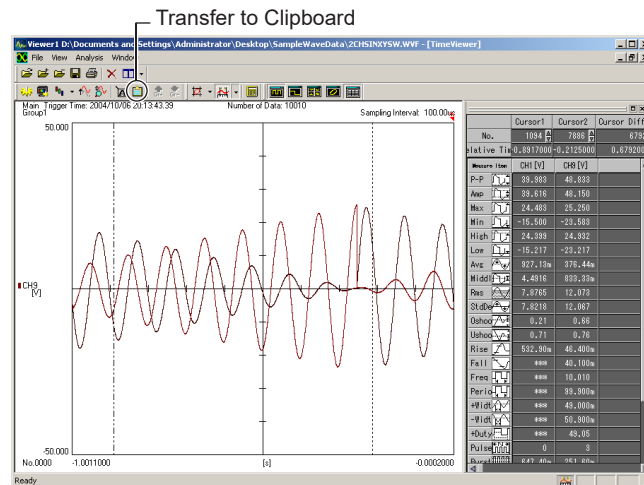

Note

Only the waveform view is transferred to the clipboard without any image of the menu bars and other functional components.

5.1 Saving Waveform Data

Procedure

Saving Waveform Data in Binary Format

Click  or select **File > Save As** to display the Save File dialog box. Set the save destination and the file name, set Save as type to **YOKOGAWA waveform file (*.wvf)** or **YOKOGAWA waveform file (*.wdf)**, set comments and necessary options, and click **Save**.

To set the options, click **More Options**.

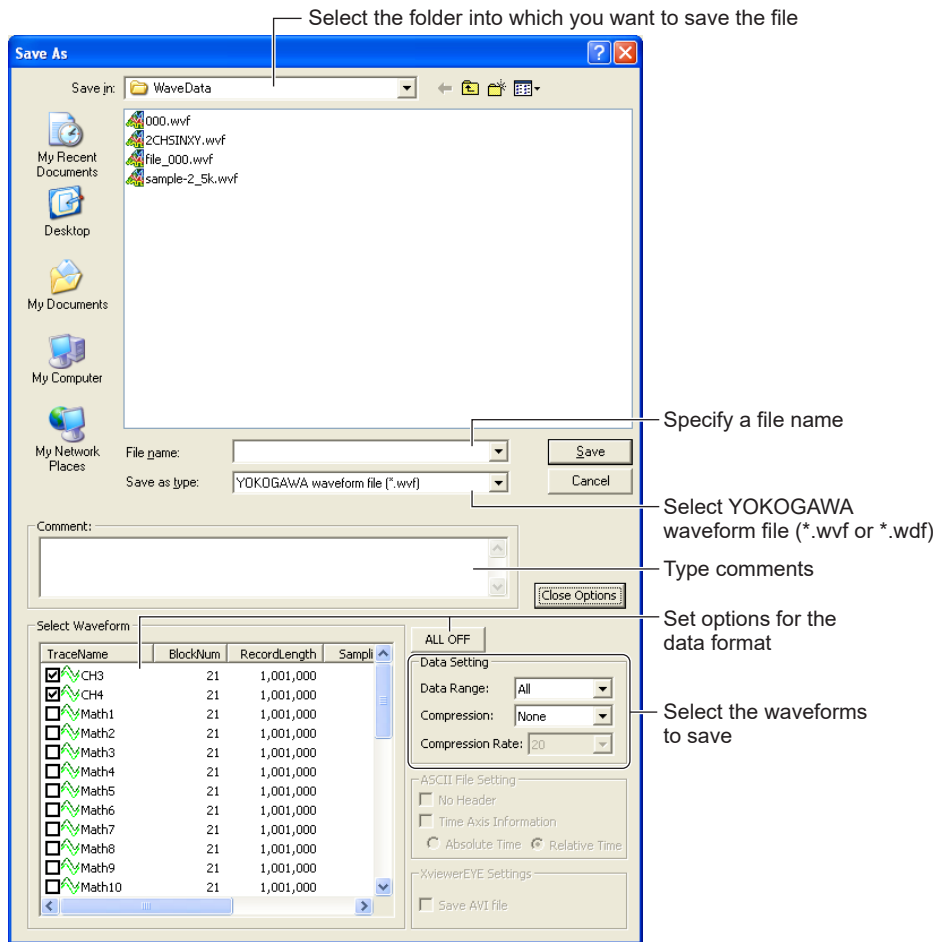

WVF Files

Saved WVF files can not be loaded on the measuring instrument*.

* DL series, SL1400, SL1000

WDF Files

WDF files cannot be loaded on the measuring instrument.

5.1 Saving Waveform Data

Saving Waveform Data in ASCII Format

Click  or select **File > Save As** to display the Save File dialog box. Select the folder into which you want to save the file, specify the file name, select **ASCII file (*.csv)** in Files of type, set any other required options, and then click **Save**. To set the options, click **More Options**.

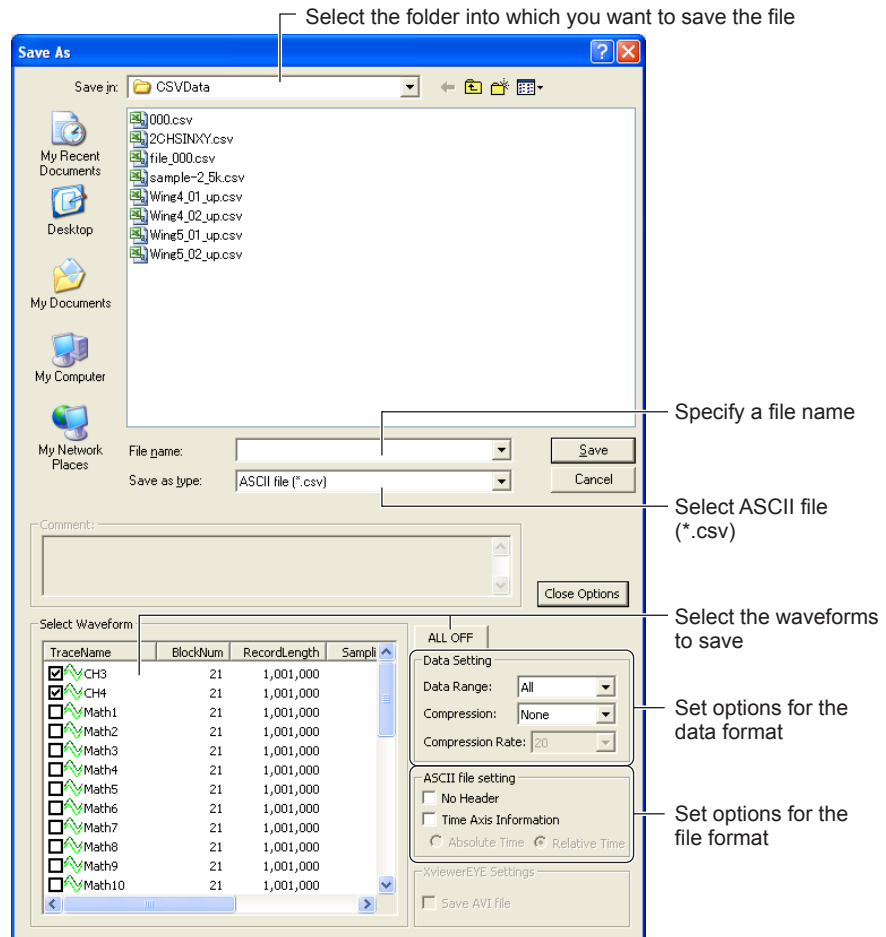

Saving Waveform Data in XLS Format

Click  or select **File > Save As** to display the Save File dialog box. Select the folder into which you want to save the file, specify the file name, select **Excel file (*.xls)** in Files of type, set any other required options, and then click **Save**. To set the options, click **More Options**.

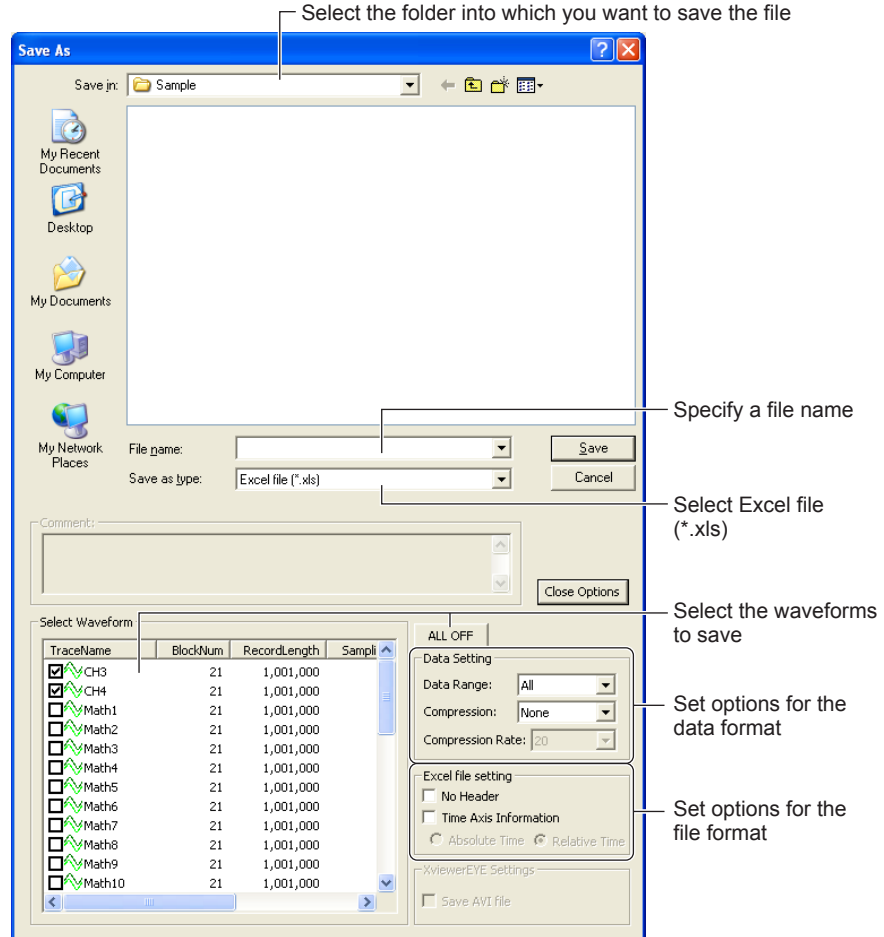

5.1 Saving Waveform Data

Saving as a Floating Point Decimal File

For products of version 1.60 or later, you can save waveform data as a floating point decimal file.

Click , or select **File > Save As** to display the Save File dialog box. Select the folder into which you want to save the file, specify the file name, select **Floating Decimal Point (*.fld)** in Files of type, set any other required options, and then click **Save**. To set the options, click **More Options**.

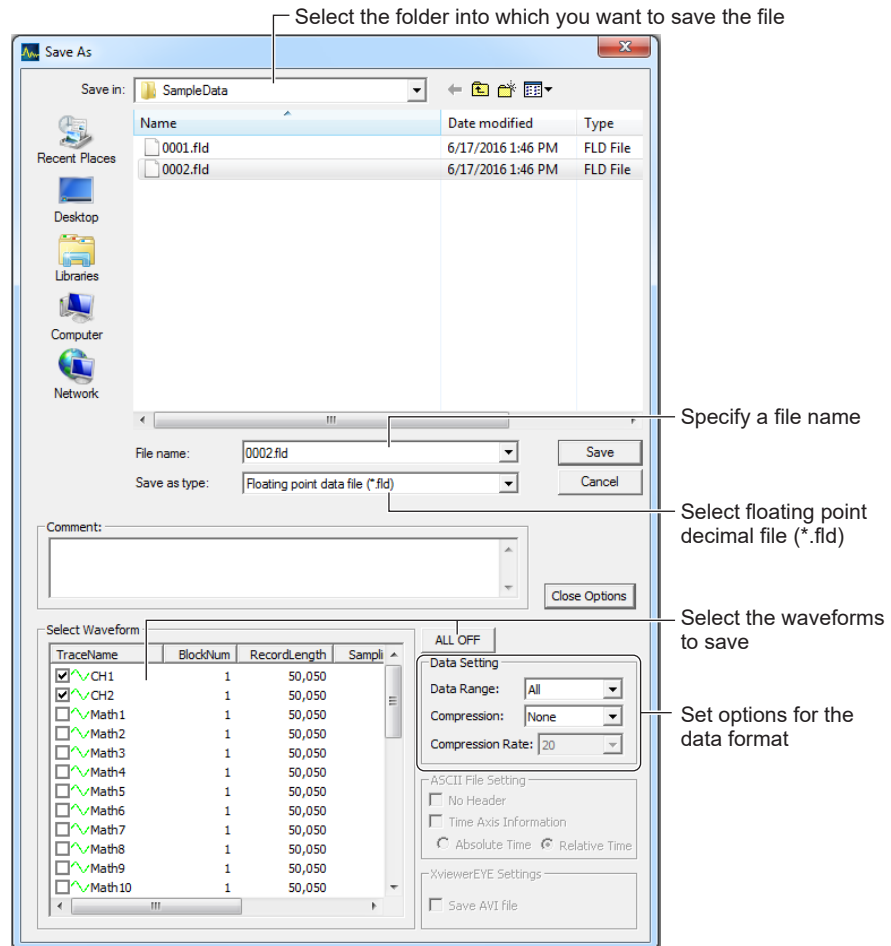

Saving Waveform Data in MATLAB Format

For products of version 1.80 or later, you can save waveform data as a floating point decimal file.

Click  or select **File > Save As** to display the Save File dialog box. Select the folder into which you want to save the file, specify the file name, select **MATLAB file (*.mat)** in Files of type, set any other required options, and then click **Save**. To set the options, click **More Options**.

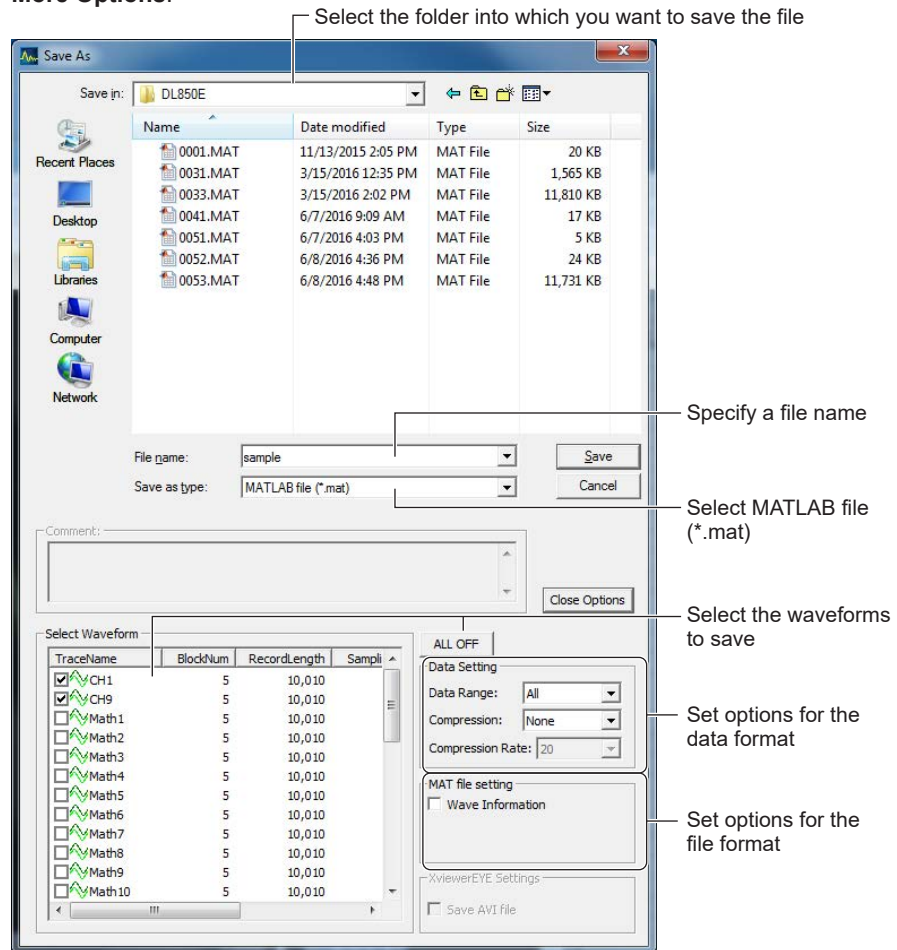

Explanation

Files Saved in Binary Format

Displayed waveform data are saved in WVF format (a Yokogawa proprietary format) and WDF format (a Yokogawa proprietary format).

The saved data consists of the active waveform data and that for the block checked in the history window.

Options for Saving Binary Files

When you save waveform data in WVF format or WDF format, you can not only select the waveforms to save but you can also set the following options:

- Range to save: Select All, Zoom Range, or Cursor Range
- Compression: Select None, PP Comp, or Decim
- Compression Rate: Selectable when Compression is specified.
Select 2, 5, 10, 20, 50, 100, 200, 500, 1000, 2000, 5000, or 10000.

* Only when the Compression is set to 'Decim', you can select the compression rate 2.

Note

- Data cannot be saved to WVF format if the file size exceeds 2 GB.

5.1 Saving Waveform Data

Files Saved in ASCII Format

Files saved in ASCII format conform to CSV format.

Note

- For waveform data that is divided into blocks, you can save only one block in ASCII format (CSV file).
-

Options for Saving CSV Files

When you save waveform data in CSV format, you can not only select the waveforms to save but also set the following options:

Data Settings

- Range to save: Select All, Zoom Range, or Cursor Range
- Compression: Select None, PP Comp, or Decim
- Compression Rate: Selectable when Compression is specified.
Select 2, 5, 10, 20, 50, 100, 200, 500, 1000, 2000, 5000, or 10000.
* Only when the Compression is set to 'Decim', you can select the compression rate 2.

File Settings

- Header: Select whether to set a header
- Time-Axis: Select whether to set information about the time-axis
- Relative Time/Absolute Time: Selecting Absolute or Relative Time (Available When the Time Axis Information Check Box Is Selected)

Relative Time: Displays the measurement time relative to the trigger position. Displays and saves data to the left of the on-screen trigger position as negative values, and data to the right as positive values.

Example: -0.00499984, 0 (Trigger position), 0.00499984

Absolute Time: Displays and saves data at the actual measured time (per the clock).

Year/Month/Day Hour:Minute:Second

Example: 2007/07/07 18:03:47.4750002,
2007/07/07 18:03:47.48,
2007/07/07 18:03:47.4849998

Files Saved in XLS Format

Files saved in XLS format conform to MS Excel format.

Options for Saving XLS Files

When you save waveform data in XLS format, you can not only select waveforms to save but also set the following options:

Data Settings

- Range to save: Select All, Zoom Range, or Cursor Range
- Compression: Select None, PP Comp, or Decim
- Compression Rate: Selectable when Compression is specified.
Select 2, 5, 10, 20, 50, 100, 200, 500, 1000, 2000, 5000, or 10000.
* Only when the Compression is set to 'Decim', you can select the compression rate 2.

File Settings

- Header: Select whether to set a header
- Time-Axis: Select whether to set information about the time-axis

Note

For waveform data divided by the block, you can save only one block you focus on into the XLS format.

File names:

The following file names cannot be used.
AUX, CON, PRN, NUL, CLOCK, COM0 to COM9, and LPT0 to LPT9

File Saved in Floating Point Decimal Format

File saved in floating point decimal format (FLD format).
FLD files can be loaded by general purpose analysis software such as MATLAB.

Options for Saving FLD Files

When saving waveform data to FLD format, you can not only select the waveforms to save but also set the following options:

Data Settings

- Range to save: Select All, Zoom Range, or Cursor Range
- Compression: Select None, PP Comp, or Decim
- Compression Rate: Selectable when Compression is specified.
Select 2, 5, 10, 20, 50, 100, 200, 500, 1000, 2000, 5000, or 10000.
* Only when the Compression is set to 'Decim', you can select the compression rate 2.

File names:

The following file names cannot be used.
AUX, CON, PRN, NUL, CLOCK, COM0 to COM9, and LPT0 to LPT9

Files Saved in MATLAB Format

Files saved in MATLAB format.

Options for Saving MATLAB Files

When you save waveform data in MATLAB format, you can not only select waveforms to save but also set the following options:

Data Settings

- Range to save: Select All, Zoom Range, or Cursor Range
- Compression: Select None, PP Comp, or Decim
- Compression Rate: Selectable when Compression is specified.
Select 2, 5, 10, 20, 50, 100, 200, 500, 1000, 2000, 5000, or 10000.
* Only when the Compression is set to 'Decim', you can select the compression rate 2.

MAT File Settings

- Variables that store time settings and other waveform information are included in the file.

When a file that includes waveform information is opened with Xviewer, time axis information and other measurement information can be displayed.

Note

- Data cannot be saved to MATLAB format if the file size exceeds 2 GB.
- Depending on the tool that you use, you may not be able to load files that were saved with waveform information.
- If multiple blocks are selected in the history window, only the waveform data of the first block is saved.
- MATLAB files saved with this software is in Level 5 MAT-File Format.
They can be loaded into MATLAB Version 5 (R8) and later.

File names:

The following file names cannot be used.
AUX, CON, PRN, NUL, CLOCK, COM0 to COM9, and LPT0 to LPT9

5.2 Transferring Waveform Data into Excel

Procedure

Transferring Waveform Data into Excel

Click  or select **File > Save As** to display the Save File dialog box. Select **Excel transport (*.*)** in Files of type, set any other required options, and then click **Save**. To set the options, click **More Options**.

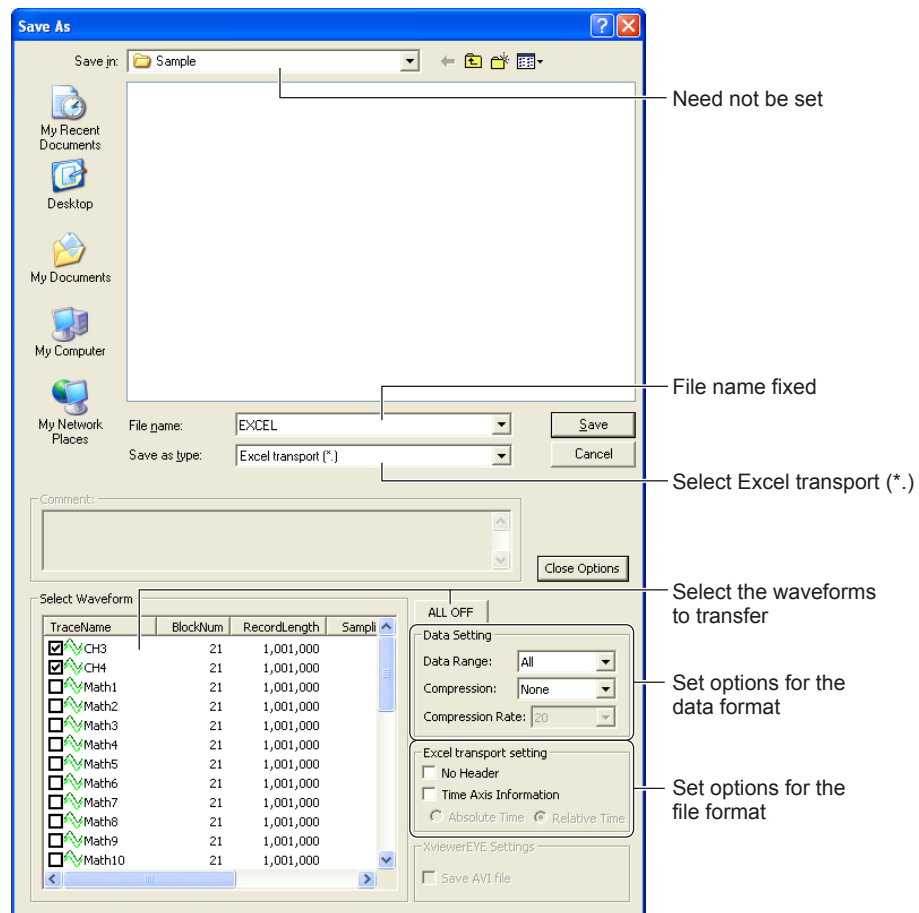

Explanation

Transfer to Excel

The Transfer to Excel command directly redirects data for the selected waveforms to an Excel sheet. Clicking the **Save** button automatically starts up Excel and then plots the waveform data onto an Excel sheet according to the specified format options.

Note

- If there are a number of channels, Transfer to Excel may take a long time to complete in some operating environments. In such a case, save the data into a CSV file, and then read the file into Excel.
- Using the mouse to close the sheet opened by the Transfer to Excel feature causes Xviewer to malfunction when you execute Transfer to Excel again. If you need to close the sheet and execute Transfer to Excel again, close the first sheet, quit Xviewer, and then execute Transfer to Excel again.
- When the measured values exceed the measurement range, or the size of the computed waveform data is smaller than that of the measured waveform data, the waveform data is not saved. In this case, a value of "65535" is written into each cell.

Options for Transfer to Excel

When you transfer waveform data to Excel, you can not only select the waveforms to transfer but also set the following options:

Data Settings

- Range to save: Select All, Zoom Range or Cursor Range
- Compression: Select None, PP Comp, or Decim
- Compression Rate: Selectable when Compression is specified.
Select 2, 5, 10, 20, 50, 100, 200, 500, 1000, 2000, 5000, or 10000.
 - * Only when the Compression is set to 'Decim', you can select the compression rate 2.

File Settings

- Header: Select whether to set a header
- Time-Axis: Select whether to set information about the time-axis

5.3 Saving Waveform Data in a View

Procedure

Saving Waveform Data in a View

Click  or select **File > Save As** to display the Save File dialog box. Select the folder into which you want to save the file, specify the file name, select **Image file (*.bmp)** or **Image file (*.png)** in Files of type, and then click **Save**.

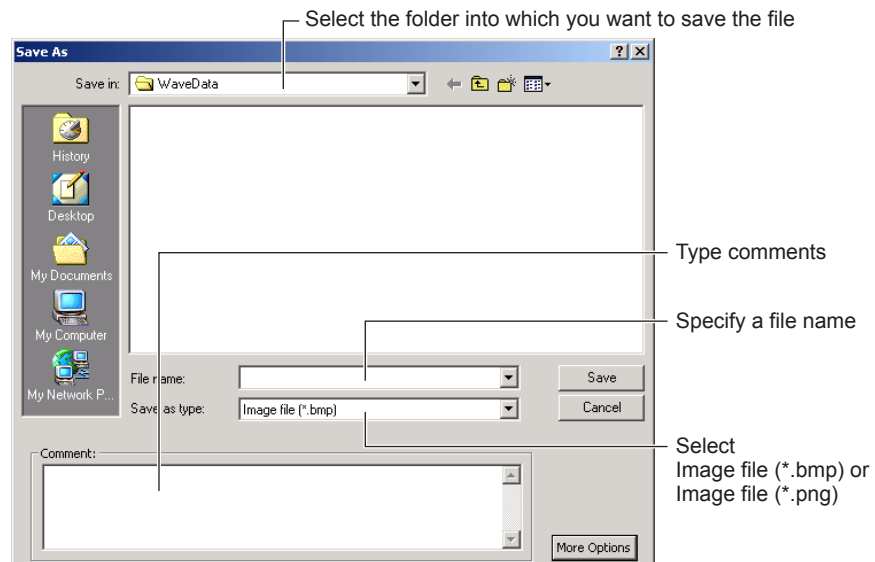

Explanation

Files Saved in BMP/PNG Format

You can save the viewer window you are viewing into an image data file in either BMP or PNG format. You can attach comments to the file, but the file can include only one line of comments.

5.4 Saving Automated Measurement Values for Waveform Parameters

Procedure

Saving Values Automated Measurement Waveform Parameters

Click  or select **File > Save As** to display the Save File dialog box. Select the folder into which you want to save the file, specify the file name, select **Waveform parameter (*.csv)** in Files of type, and then click **Save**.

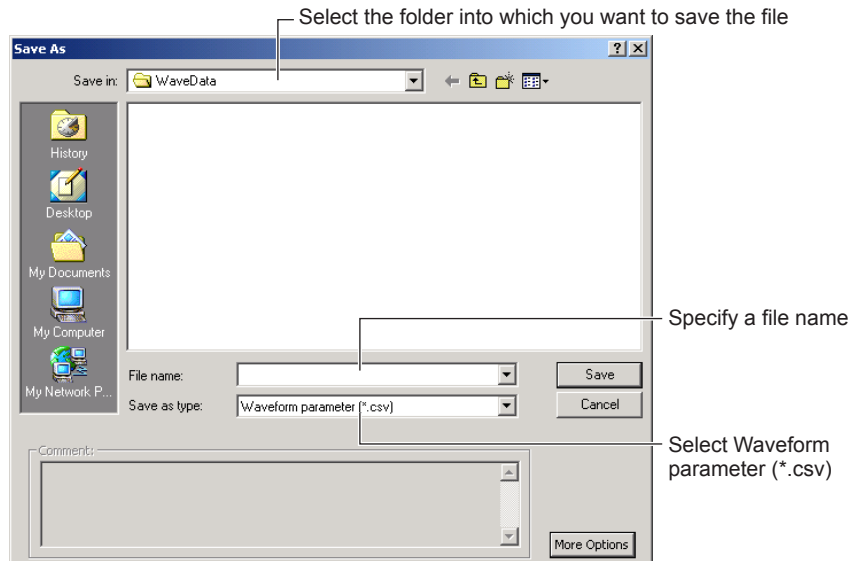

Explanation

Files Saved in Waveform Parameters (*.csv) Format

You can save the automated measurement values for the specified waveform parameters, history statistics, and cycle statistics (values displayed in the measurement result display window) in a .csv file.

Saved Data

Among the automated measurement values, the following data is saved.

- Measurement results for block selected in the history window
- Trace measurement results for channel setting for which the cursor display is ON

5.5 Saving the Display Settings

Procedure

Saving the Display Settings

Click  or select **File > Save As** to display the Save File dialog box. Select the folder into which you want to save the file, specify the file name, select **Setting info (*.xml)** in Files of type, and then click **Save**.

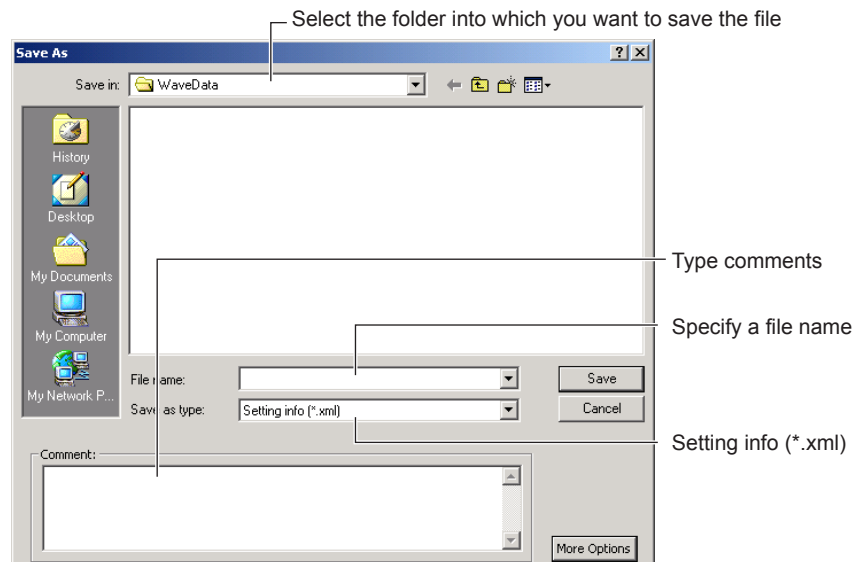

Explanation

Files Saved in Setting info (*.xml) Format

You can save the display settings specified for the viewer window you are viewing into a .xml file. You can also include comments. Loading a Display Setting file already saved applies the display settings in the file to waveform views.

Automatically Saving Display Settings

With software products of version 1.34 or later, when waveform data analysis is finished, the corresponding display settings are automatically saved.

The next time waveform data is loaded, the corresponding display settings are automatically loaded.

Note

The function that saves display settings automatically uses the MD5 Message Digest Algorithm by RSA Data Security, Inc.

5.6 Converting Multiple Waveform Data Files to CSV Files

Procedure

1. Close the viewer window.
2. Click **Tool > CSV Multiple files conversion** on the Xviewer tool bar to display the CSV Multiple files conversion dialog box.

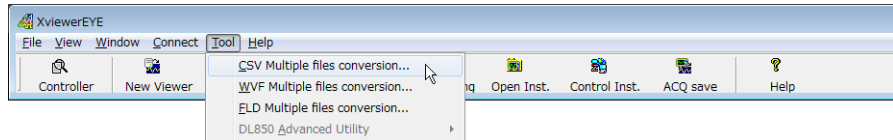

3. Select the files (WVF or WDF files)* to convert and options and click **Save**. The Browse For Folder dialog box opens.

* You can select one or more WVF and WDF files for conversion. To select multiple files, hold down the Ctrl key while clicking to select them. When multiple files are selected, all are converted to CSV files collectively.

Example with multiple selected files

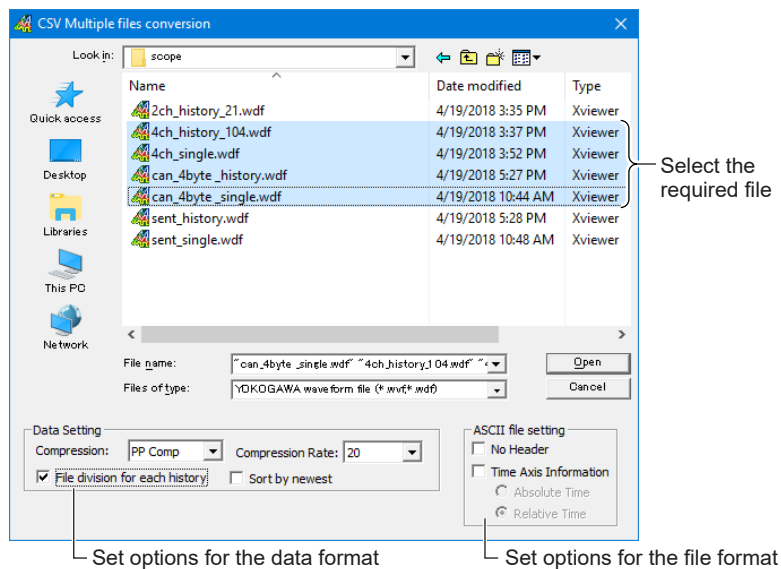

4. Select a save destination folder and click **OK**. The converted CSV files are saved in the selected folder.
Converted files are only given the csv file name extension.

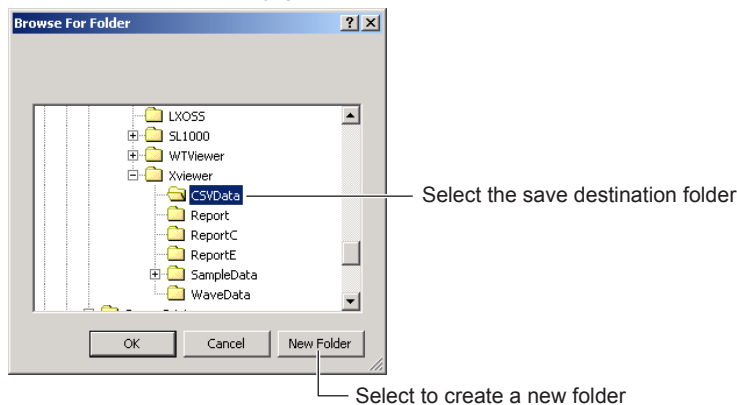

Explanation

Option Settings

You can specify the following two options for waveform data files to convert to the CSV format:

Data Settings

- Compression: Select None, PP Comp, or Decim
- Compression Rate: Selectable when Compression is specified. Select 2, 5, 10, 20, 50, 100, 200, 500, 1000, 2000, 5000, or 10000.
 - * Only when the Compression is set to 'Decim', you can select the compression rate 2.
- File division for each history: Select whether to divide file into every history waveform.
- Sort by newest: When selected, data is saved in increasing order by history number.

File Settings

- Header: Select whether to set a header
- Time-Axis: Select whether to set information about the time-axis
- Relative Time/Absolute Time: Selecting Absolute or Relative Time (Available When the Time Axis Information Check Box Is Selected)

Relative Time: Displays the measurement time relative to the trigger position. Displays and saves data to the left of the on-screen trigger position as negative values, and data to the right as positive values.

Example: -0.00499984, 0 (Trigger position), 0.00499984

Absolute Time: Displays and saves data at the actual measured time (per the clock).

Year/Month/Day Hour:Minute:Second

Example: 2007/07/07 18:03:47.4750002,
2007/07/07 18:03:47.48,
2007/07/07 18:03:47.4849998

Records Horizontally Arranged

CH1-Record1-data001, CH2-Record1-data001
CH1-Record1-data002, CH2-Record1-data002
CH1-Record1-data003, CH2-Record1-data003

⋮ ⋮

CH1-Record1-data100, CH2-Record1-data100

CH1-Record2-data001, CH2-Record2-data001
CH1-Record2-data002, CH2-Record2-data002
CH1-Record2-data003, CH2-Record2-data003

⋮ ⋮

CH1-Record2-data100, CH2-Record2-data100

CH1-Record3-data001, CH2-Record3-data001
CH1-Record3-data002, CH2-Record3-data002
CH1-Record3-data003, CH2-Record3-data003

⋮ ⋮

CH1-Record3-data100, CH2-Record3-data100

5.7 Converting WDF Files to WVF Files

Procedure

1. Close the viewer window.
2. Click **Tool > WVF Multiple files conversion** on the Xviewer tool bar to display the WVF Multiple files conversion dialog box.

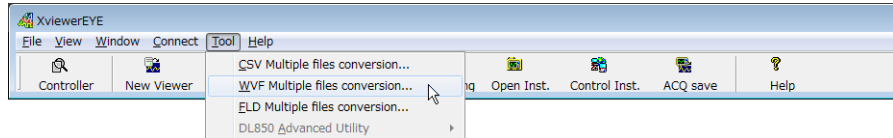

3. Select the WDF files* to convert and options and click **Save**. The Browse For Folder dialog box opens.

* You can select one or more WDF files for conversion. To select multiple files, hold down the Ctrl key while clicking to select them. When multiple files are selected, all are converted to WVF files collectively.

Example with multiple selected files

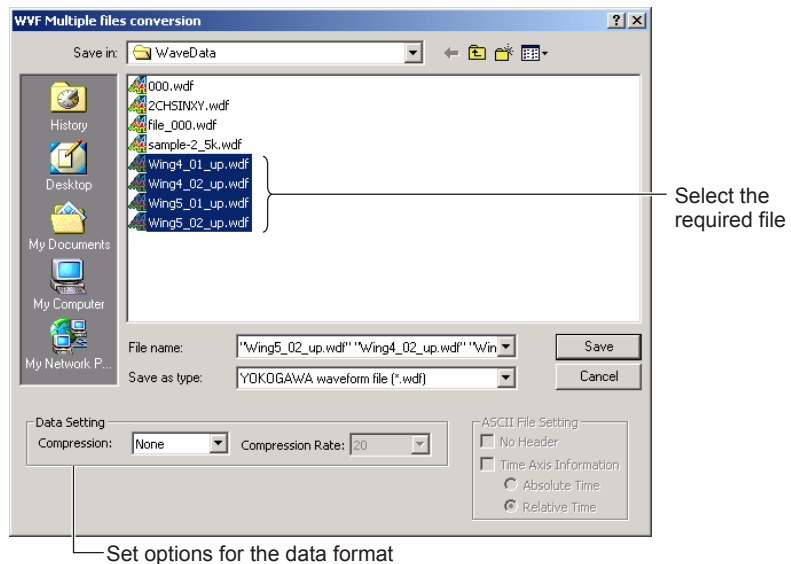

4. Select a save destination folder and click **OK**. The converted WVF files are saved in the selected folder. Converted files are only given the wvf file name extension. Converted WVF files can not be loaded on the measuring instrument.

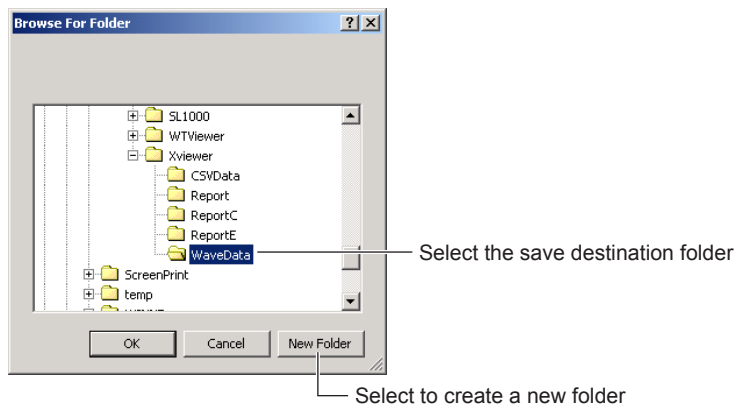

Explanation

Option Settings

When converting a WDF file containing measured waveform data to WVF format, you can select WVF format options. The options that can be specified are as follows.

Data Settings

- Compression: Select None, PP Comp, or Decim
- Compression Rate: Selectable when Compression is specified.
Select 2, 5, 10, 20, 50, 100, 200, 500, 1000, 2000, 5000, or 10000.
 - * Only when the Compression is set to 'Decim', you can select the compression rate 2.

Note

Data cannot be saved to WVF format if the file size exceeds 2 GB.

5.8 Converting WDF/WVF Files to FLD Files

Procedure

1. Close the viewer window.
2. Click **Tool > FLD Multiple files conversion** on the Xviewer tool bar to display the FLD Multiple files conversion dialog box.

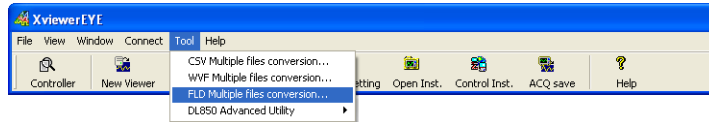

3. Select the WDF/WVF files to convert* and any options, then click **Save**. The browse folders dialog box is displayed.
* You can select one or more WDF/WVF files for conversion. To select multiple files, hold down the Ctrl key while clicking to select them. When multiple files are selected, all are converted to FLD files collectively.
4. Select a save destination and click **OK**. The converted FLD file is saved in the selected folder.

Converted files are only given the fld file name extension.

Converted FLD files can not be loaded on the measuring instrument.

Explanation

Option Settings

When converting a WDF file containing waveform data to FLD format, you can select FLD format options.

Data Settings

- Compression: Select None, PP Comp, or Decim
- Compression Rate: Selectable when Compression is specified.
Select 2, 5, 10, 20, 50, 100, 200, 500, 1000, 2000, 5000, or 10000
- * Only when the Compression is set to 'Decim', you can select the compression rate 2.

Note

- Data cannot be saved to FLD format if the file size exceeds 2 GB.
- FLD files are in single precision floating point decimal format.
- FLD files can be loaded by general purpose analysis software such as MATLAB.

6.1 Setting Up a Printer

Procedure

Setting Up a Printer

Select **File > Printer Setup....** to display the Printer Setup dialog box.

Select a printer and specify the paper size, orientation, and other settings in the dialog box, and then click **OK**.

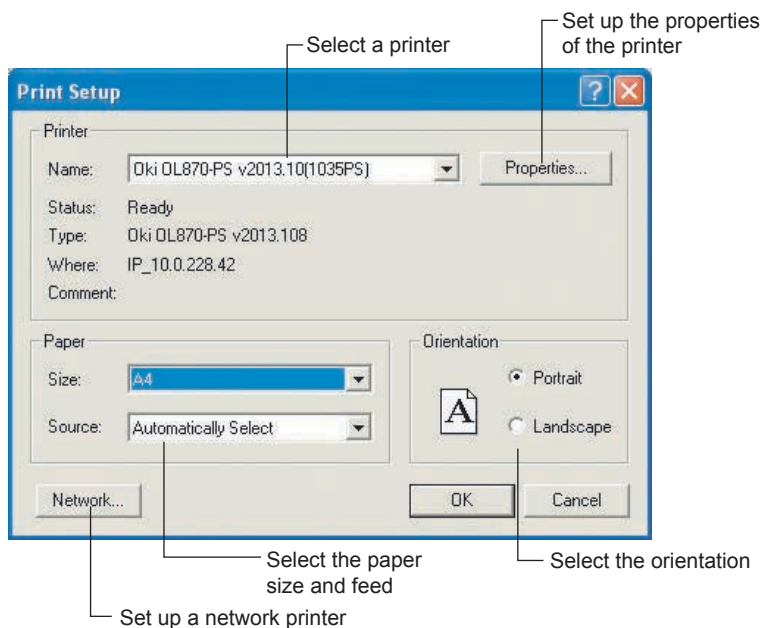

Explanation

Set up the printer according to your system configuration.

6.2 Printing Displayed Waveforms

Procedure

Setting Up the Print Format

Select **File > Print Format** to display the Print Format dialog box. Fill in the comment, header, and footer fields, specify the print mode settings, and then Click **OK**.

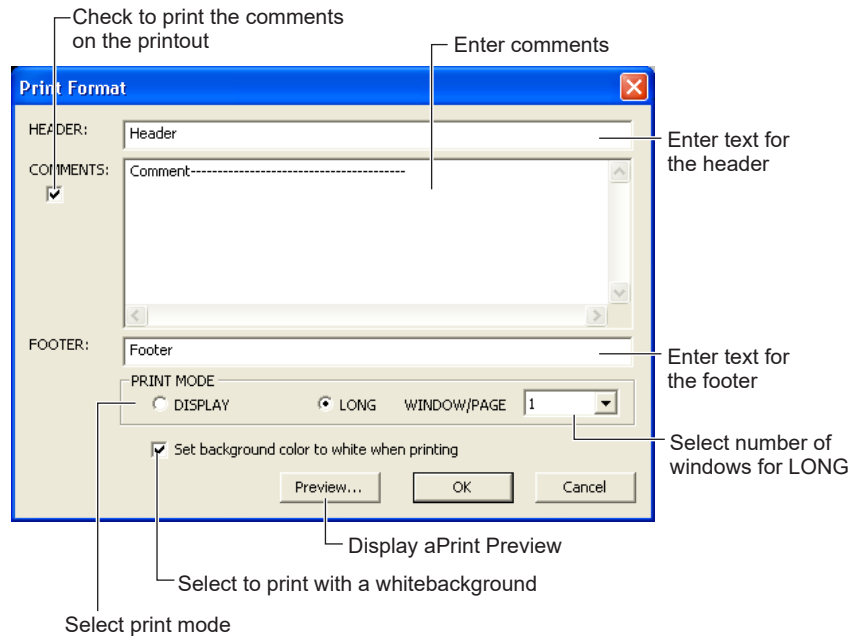

Printing

Click  to display the Print dialog box. Click **OK** to start printing with the settings you specified in the Print Format dialog box.

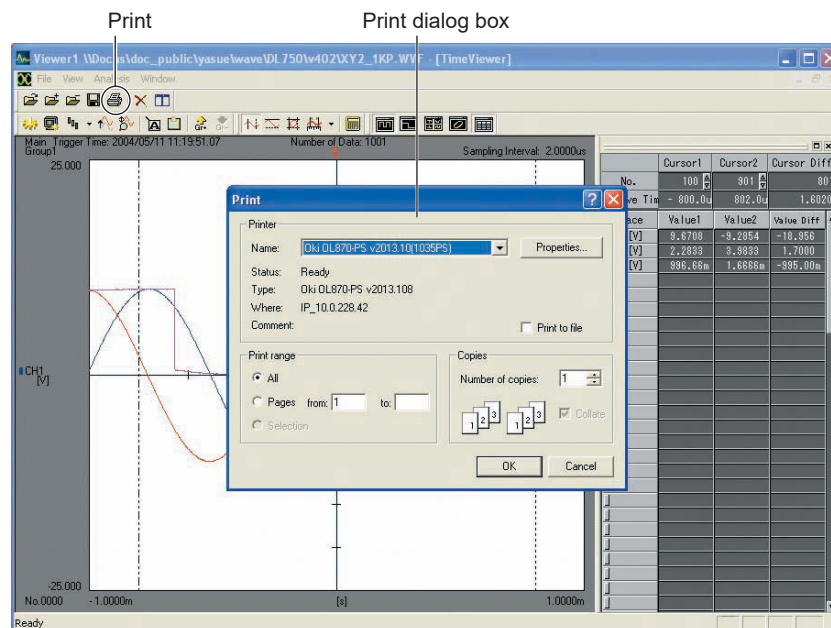

Explanation

Printable Information

You can specify the printing of the following types of information on printouts:

- **COMMENTS:** Comments (printed under the waveforms.)
- **HEADER:** Page header
- **FOOTER:** Page footer

Print Mode

Set the following items for the PRINT MODE selections:

- **DISPLAY:** Mode in which the display on the screen is printed as is
- **LONG:** Prints the waveforms (main waveform display window), separating them by the zoom rate specified for the zoomed waveform display window. (The entire waveform view is printed by the zoomed waveform display window, starting from the left end. In the dialog box, the size of the zoomed waveform display window is in units of one window*.) Set a value of 1 to 10 for "WINDOW/PAGE" for the number of windows to be printed on one page.

* The number of windows printed equals (the number of points displayed in the main waveform display windows) divided by (the number of points displayed in the zoomed waveform display windows), or (quotient of the division) + 1.

Print Preview

Click **Preview** or select **File > Print Preview** to switch the viewer window to the print preview. This lets you check the layout of the sheet you are going to print. To proceed with printing, click **Print**.

Printout Sample

Print Mode: DISPLAY

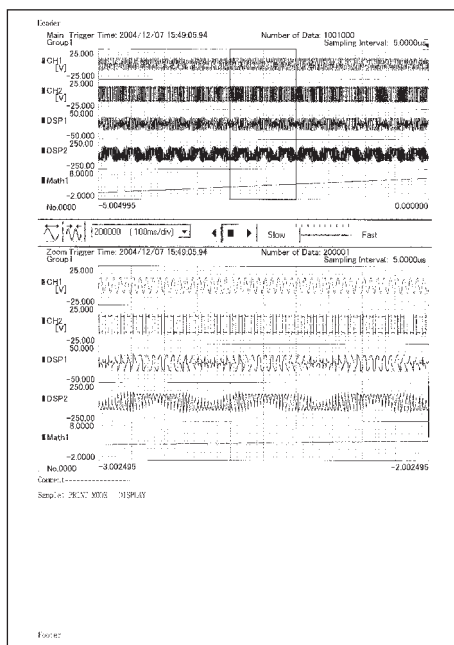

Print Mode: LONG

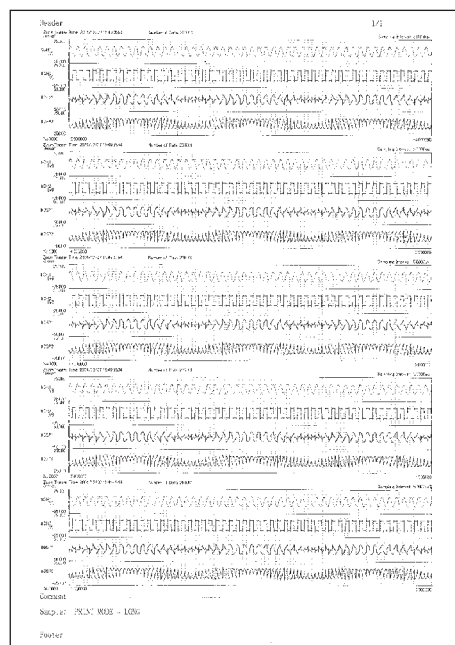

6.2 Printing Displayed Waveforms

Printing Background

Select a background color to use when printing.

- **Select:** Prints with a white background.
- **Clear:** Prints with the background color displayed on screen.

Printing Example

When printing with the on-screen background color

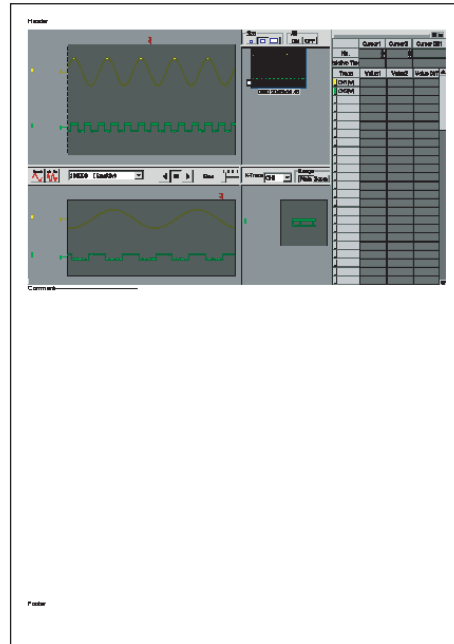

When printing with the background color set to white

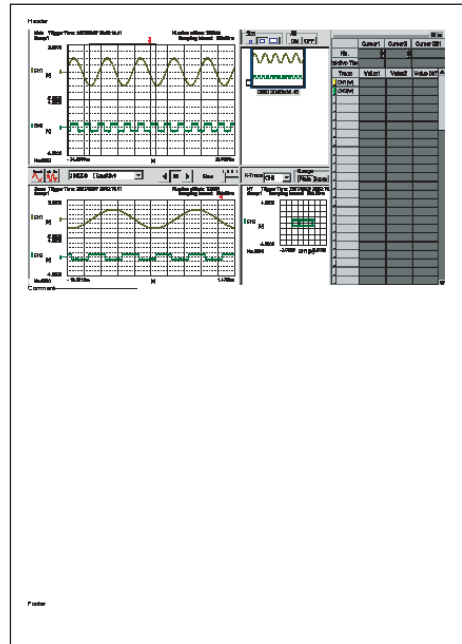

7.1 Using the Report Function (Xreport)

Procedure

Starting the Report Function

While waveforms are shown on the Viewer window, choose **Create Report** from the **File** menu. The Xreport window opens.

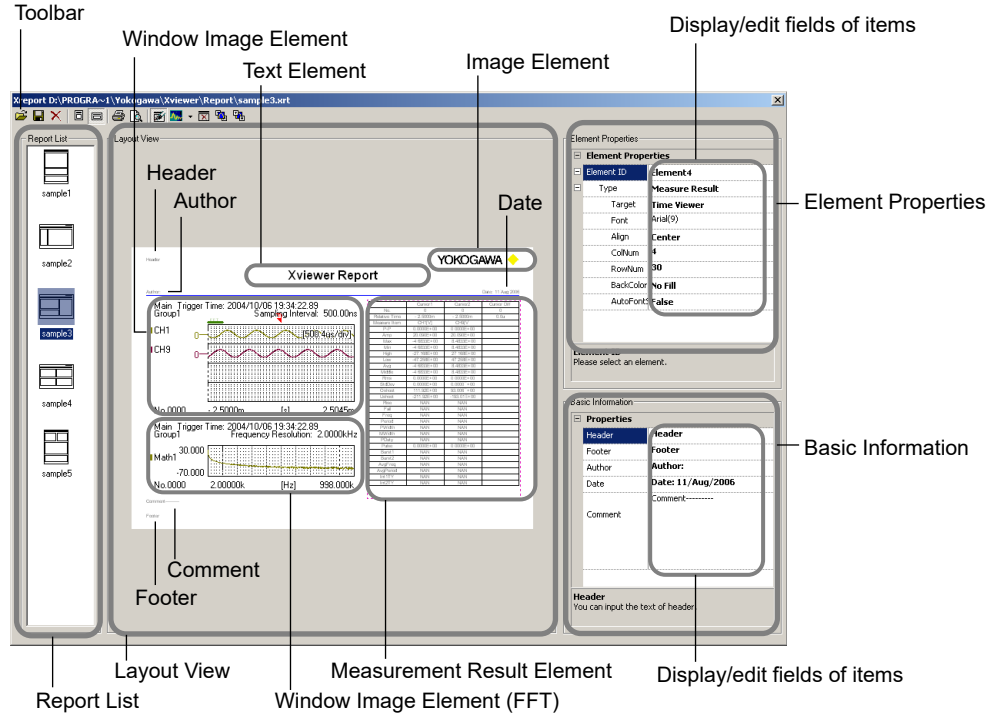

• Toolbar

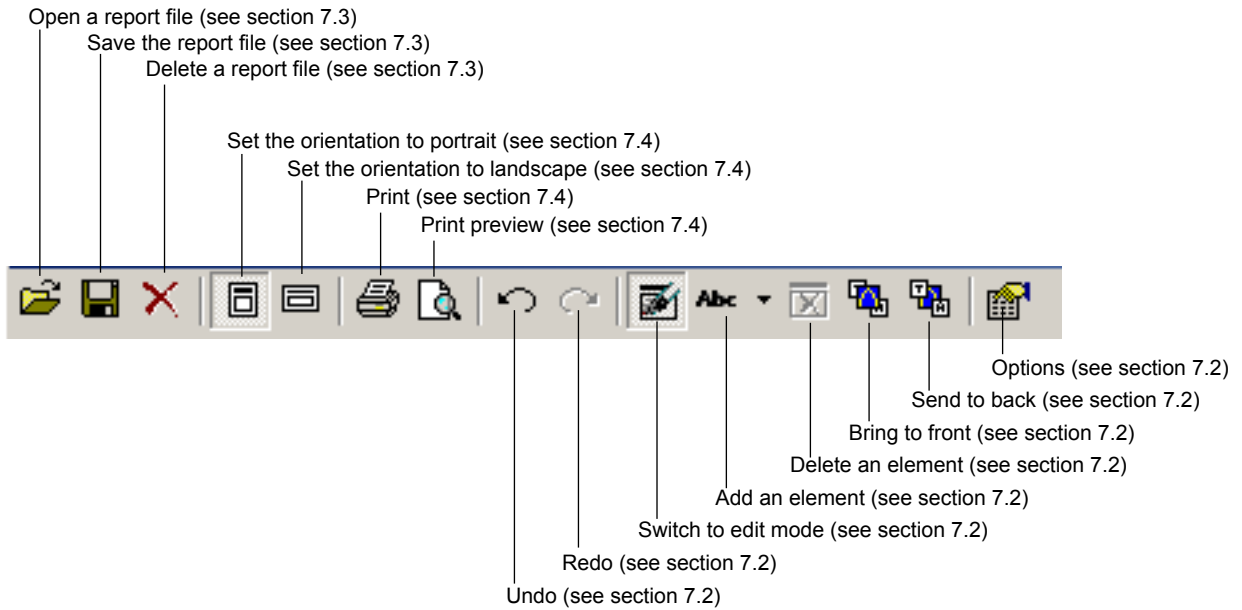

Explanation

Starting the Report Function

If you start the report function, the Xreport window opens. The window shows the waveform that was shown on the Viewer window.

Xreport Window

The Xreport window consists of the following four items.

- Report List: Lists the report files with a layout image.
- Layout View: Shows elements such as waveforms and measured results.
- Element Properties: Shows/edits the properties of each element.
- Basic Information: Shows/edits the header, footer, author, date, and comment.

Report List

The report files saved in the folder below are listed with a layout image.

Xviewer installation folder > Report folder

(The default location is C:\Program Files\Yokogawa\Xviewer\Report)

The report file stores position information and properties of each element that is positioned on the Layout View as well as basic information. The report file that you select on the Report List is used to lay out the Layout View.

By default, the five report files (Sample1 to 5) are available. You can edit these files.

Layout View

The Layout View consists of elements, the header, the footer, the date, and the comment. There are four types of elements available, and multiple elements can be placed on the Layout View. When you create an element, a unique ID is assigned in order. Element1 cannot be deleted.

- Text Element: An element for placing text.
- Window Image Element:
 - An element for placing the image of the Viewer Window. You can select the main, zoom, or XY display of the Time Viewer waveform or the main, zoom, XY display of the FFT Viewer waveform.
 - However, FFT Main, FFT Zoom, and FFT XY can be placed only if the FFT Viewer is shown on the Viewer Window.
- Measurement Result Element:
 - An element for placing the measured results. The measured results do not need to be shown on the Viewer Window.
- Image Element: An element for placing the image data. A jpg, bmp, tif, or png image can be placed.

Element Properties

Shows the common properties and the properties by type for the selected element. You can change the properties by turning Edit Mode ON.

- **Common Properties**

Element ID: Assigned automatically when an element is created. It cannot be changed.

Type: Text, Window Image, Measure Result, or Image.

- **Properties by Type**

Text

Text: Text (can be edited regardless of the ON/OFF state of Edit Mode).

Font: Font, style, size, and so on to be used.

Align: Alignment (right, left, or center).

BackColor: Background color.

Window Image

Target: Time Main, Time Zoom, Time XY, FFT Main, FFT Zoom, or FFT XY.

Measure Result

Target: Time Viewer or FFT Viewer.

Font: Font, style, size, and so on to be used.

Align: Alignment (left, center, or right).

ColNum: Number of columns

RowNum: Number of rows

BackColor: Background color.

AutoFontSize: Automatic adjustment of the font size (True or False).

Image

File Path: The path to the image file. Specified in the Open dialog box.

H Align: Horizontal position (Left, Center, or Right).

V Align: Vertical position (Top, Center, or Bottom).

Zoom: Magnification (Select Auto, Fix, 0.50, or 2.00. You can also set an arbitrary magnification.)

Basic Information

Shows the header, footer, author, date, and comment. You can change the information regardless of whether Edit Mode is ON. Basic information is shown at a fixed position in the Layout View and cannot be deleted.

Note

- If you start the report function (Xreport), the contents of the Viewer Window are laid out in the Layout View according to the settings of the most recent report file in the following folder.
Xviewer installation folder > Report folder
(The default location is C:\Program Files\Yokogawa\Xviewer\Report.)
- The report list can show up to 64 report files.
- If you turn Edit Mode ON, you can change the size of each element by dragging the frame.
- Font size designation is invalid if AutoFontSize is set to True.

7.2 Editing Reports

Procedure

Selecting the Layout

Click the desired layout from the Report List. Layout View, Element Properties, and Basic Information are set according to the selected report file.

Enabling Edit Mode

Click **Edit Mode** on the toolbar. When Edit Mode is ON, you can add or delete elements and change the element properties.

Adding an Element

Select the element you want to add from the drop-down menu of **Add Element** on the toolbar. A crosshair cursor appears in the Layout View. Drag the cursor to add an element of the desired size.

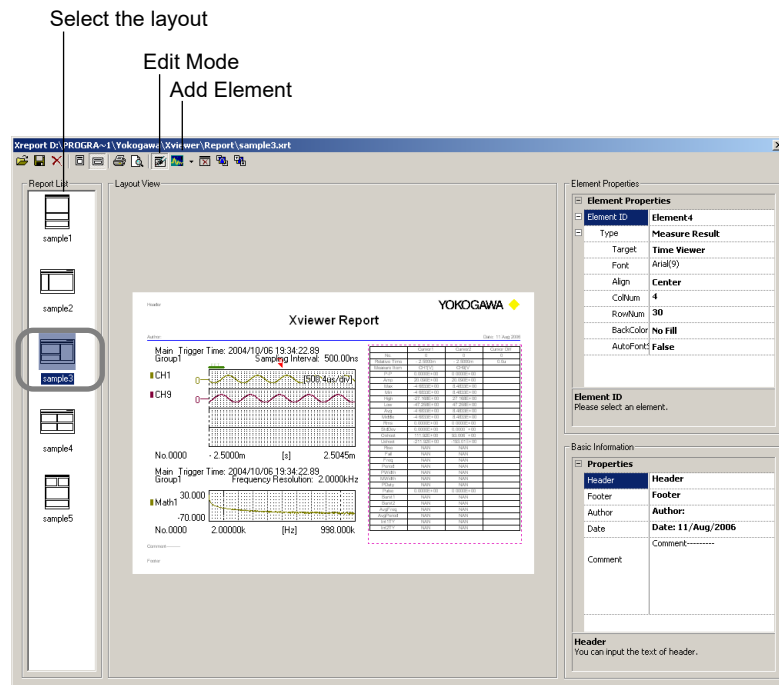

Changing the Element Properties

Click the item field you want to change.

• Editing a Text Element

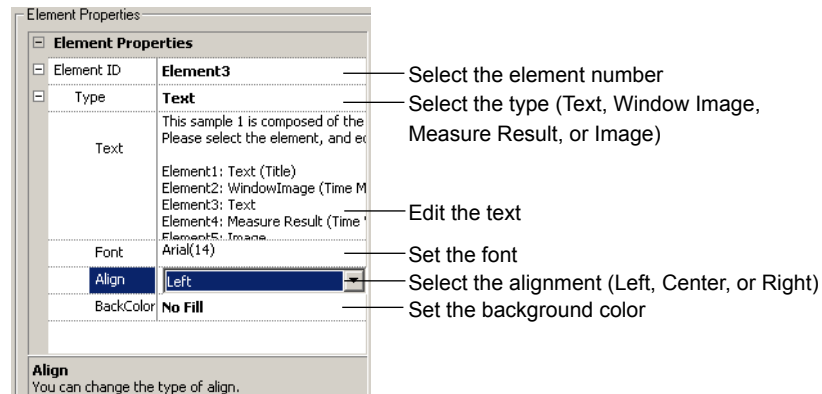

- Editing a Window Image Element

Element Properties	
Element Properties	
Element ID	Element2
Type	Window Image
Target	Time Main
Target You can select the type of waveform image.	

Select the waveform to be displayed (Time Main, Time Zoom, Time XY, FFT Main, FFT Zoom, or FFT XY)

- Editing a Measure Result Element

Element Properties	
Element Properties	
Element ID	Element4
Type	Measure Result
Target	Time Viewer
Font	MS UI Gothic(9)
Align	Center
ColNum	4
RowNum	6
BackColor	No Fill
AutoFont	True
ColNum You can set the number of column. Minimum is 1. Maximum is 30.	

Select the measured item (Time viewer or FFT Viewer)

Set the font

Select the alignment (Left, Center, or Right)

Set the number of columns

Set the number of rows

Set the background color

Turn ON/OFF the automatic adjustment of the font size (True/False)

- Editing an Image Element

Element Properties	
Element Properties	
Element ID	Element4
Type	Image
FilePath	
HAlign	Left
VAlign	Top
Zoom	Auto
FilePath You can select an image file to display.	

Specify the path to the image file

Select the horizontal position (Left, Center, or Right)

Select the vertical position (Top, Center, or Bottom)

Set the magnification of the image file* (Auto, Fix, 0.50, 2.00, or an arbitrary magnification)

- * Auto: Adjusts the size so that the image fits in the Image Element frame.
- Fix: Shows the image at the original size.
- 0.50: Shows the image at one-half the original size.
- 2.00: Shows the image at twice the original size.
- Any: Shows the image by expanding or reducing the image to an arbitrary size.

Deleting an Element

Select the element you want to delete in the Layout View. Click **Delete Element** on the toolbar. The selected element is deleted.

Sending the Element to the Back or Bringing the Element to the Front

Select the element you want to move and click **Send to Back** or **Bring to Front**.

Changes the Basic Information

Click the Header, Footer, Author, Date, or Comment field and change the contents.

Aligning the Elements

Select whether to align the elements with the grid. Click **Options** on the toolbar. The Options dialog box opens. Show/hide the grid on the layout view or set the grid spacing.

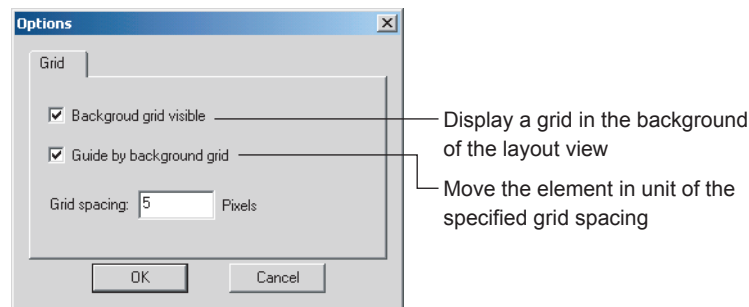

Undoing or Redoing

Undo or redo an element editing operation.

Explanation

Report List

Lists the report files (.xrt extension) that are stored in the folder below. The most recent file is shown at the top of the list; the oldest file is shown at the bottom of the list.

Xviewer installation folder > Report folder

(The default location is C:\Program Files\Yokogawa\Xviewer\Report.)

Adding an Element

When Edit Mode is ON, you can select the element to be added from the following:

- Add text (Text Element).
- Add a window image (Window Image Element).
- Add a measured result (Measure Result Element).
- Add an image (Image Element).

Changing the Element Properties

You can change the properties. The items that you can change vary depending on the type.

Changes the Basic Information

The following basic information is shown in the report.

Header, Footer, Date, Author, and Comment

The Basic Information cannot be turned OFF. However, if you leave the text field empty, nothing will be displayed.

Aligning the Elements

The selectable range is 1 to 100.

Undoing or Redoing

You can undo or redo a single edit operation in the layout view.

- Add or delete an element.
- Move an element or change the properties
- Set the layout view (landscape or portrait)
- Basic information of the report (header, footer, date, author, and comment)

7.3 Saving, Loading, or Deleting Report Files

Procedure

Loading a Report File

Click **Open** on the toolbar. The Open dialog box opens. Select the report file you want to load, and click **Open**. The report file settings are used to lay out the Layout View.

Saving a Report File

Click **Save As** on the toolbar. The Save As dialog box opens. Set the destination, file name and file type, and click **Save**. The current settings are saved.

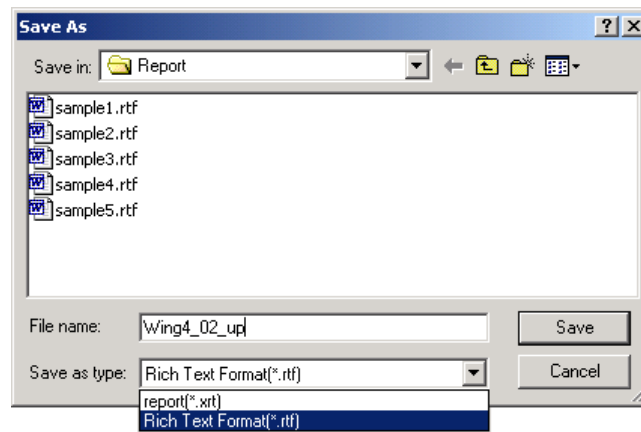

Select the file type

Deleting a Report File

Select the file you want to delete from the Report List, and click **Delete Report** on the toolbar. The selected report file is deleted.

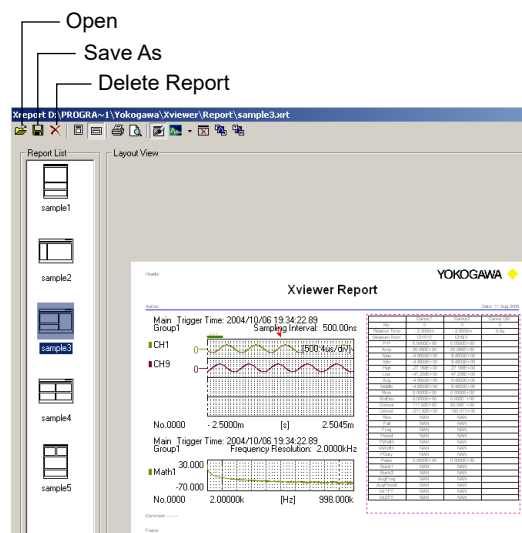

Explanation**Loading a Report File**

Use this command to open a report file that is not shown in the Report List.
The only reports that can be loaded are the ones of file type *.xrt.

Saving a Report File

If you save the report file in the folder indicated below, the report file is shown in the Report List.

Xviewer installation folder > Report folder

(The default location is C:\Program Files\Yokogawa\Xviewer\Report.)

The report file types that can be saved are *.xrt (report format) and *.rtf (rich text format).

Note

Report files saved in rich text format (*.rtf) can be edited in Microsoft Word. However they can not be edited in WordPad.

Deleting a Report File

The report files in the folder indicated below can be deleted.

Xviewer installation folder > Report folder

(The default location is C:\Program Files\Yokogawa\Xviewer\Report.)

Note

If you open a new report file, the report file that was open up to that point is discarded.

7.4 Printing Reports

Procedure

Selecting the Print Orientation

Click **Portrait** or **Landscape** on the toolbar.

Print Preview

Click **Print Preview** on the toolbar. A preview is shown on the screen.

Printing a Report

Click **Print** on the toolbar. The Print dialog box opens. Set the printer, the range, the number of copies, and so on, and click **OK**. The report is printed on the specified printer.

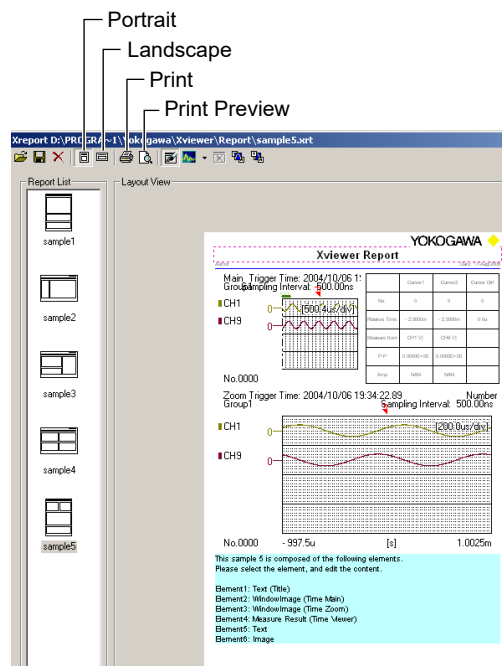

8.1 Connecting to the Instruments

Note

Before attempting to use this function, connect the PC to the instrument using an appropriate communications cable. For details on how to make this connection, see the manual provided with your instrument.

Procedure

Setting Up/Adding a Connection

On the **Xviewer tool bar**, click **CommSetting** to open the Communication Setting dialog box. Then, click **Add** to open the Devices dialog box, make the settings for the connection interface and communications conditions, and then click **OK**.

Note

- If connections to instruments have already been registered, those connections will be displayed as a list. Select the required instrument and then click Connect to establish the connection with the instrument.
- Up to 16 connections can be registered.

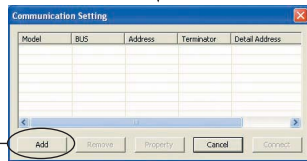
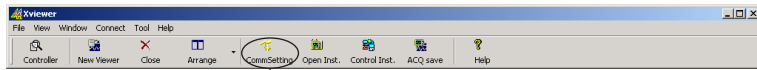

• GP-IB connection



Input the GP-IB address of the instrument to be connected (0 to 30)

- USB connection (Other than the DL9000/SB5000 Series, SL1000, DLM2000 series, DLM3000 series, DLM4000 series, DLM5000 series, DL6000/DLM6000 series, DL850 series, and DL350 series)

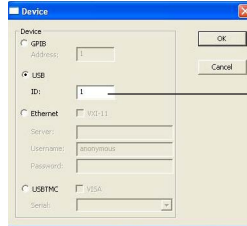

Input the USB ID number of the instrument to be connected (1 to 127)

- USB connection (DL9000/SB5000 Series, SL1000, DLM2000 series, DLM3000 series, DLM4000 series, DLM5000 series, DL6000/DLM6000 series, DL850 series, and DL350 series)

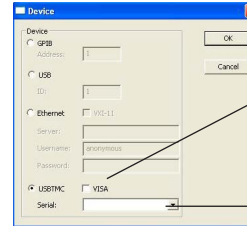

Select VISA when connect to the instrument using IVI driver.
Select the serial number of the instrument to be connected (9-digit)

- Network connection (Other than the SL1000, DLM2000 series, DLM3000 series, DLM4000 series, DLM5000 series, DL6000/DLM6000 series, DL850 series, and DL350 series)

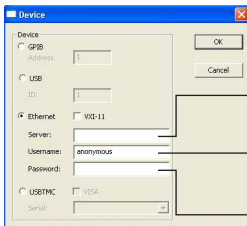

Input the IP address of the instrument to be connected
Input the network user name for the instrument to be connected
Input the network password for the instrument to be connected

- Network connection (SL1000, DLM2000 series, DLM3000 series, DLM4000 series, DLM5000 series, DL6000/DLM6000 series, DL850 series, and DL350 series)

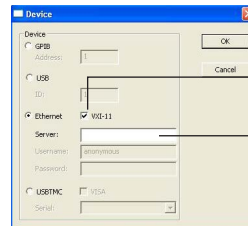

Check the VXI11
Input the IP address of the instrument to be connected

8.1 Connecting to the Instruments

Modifying a Connection

On the **Xviewer tool bar**, click **CommSetting** to open the Communication Setting dialog box. Select the required instrument and then click **Properties** to open the Devices dialog box, change the settings as needed and then click **OK**.

Removing a Connection

On the **Xviewer tool bar**, click **CommSetting** to open the Communication Setting dialog box. Select the required instrument and then click **Remove** to remove the selected connection.

Establishing a Connection

On the **Xviewer tool bar**, click **CommSetting** to open the Communication Setting dialog box. Select the required instrument and then click **Connect** to establish the connection with the instrument.

Note

If the instrument contains a very large number of files, it may take some time to establish the connection.

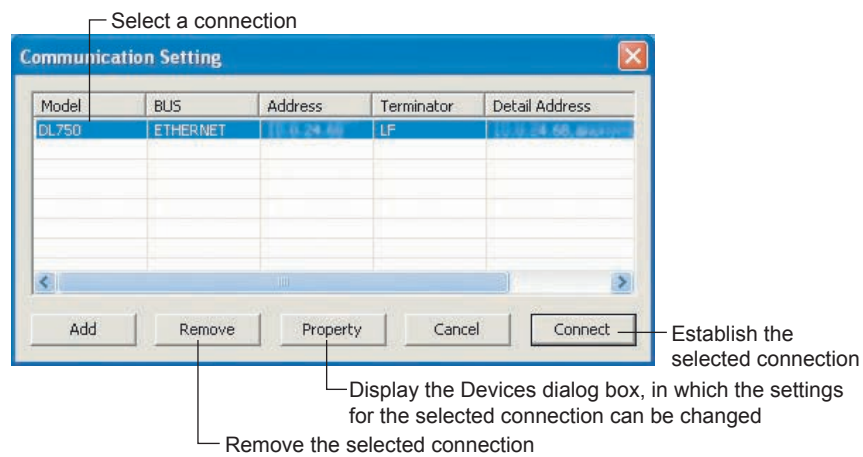

Ending a Connection

A connection with the instrument is ended when you exit from Xviewer.

Note

The connection with the instrument cannot be ended while a file is being transferred.

Explanation

Setting Contents

Ensure that the interface settings and communication conditions are the same as for the instrument to which you want to connect. Check the setting contents using the following menu.

- **Address/ID Number**

DL750 series, DL1600 series, DL1700E series:

MISC > Remote Cntl

DL7400 series:

MISC > Remote Control

DL9000 series, SB5000 series:

SYSTEM > Remote Control > GPIB

SL1400:

MENU > Remote Cntl

DLM2000 Series, DLM3000 Series, DLM4000 Series, DLM5000 Series:

UTILITY > Remote Control > Device > GPIB

DL6000/DLM6000 Series:

UTILITY > Remote Control > GPIB

DL850 series:

UTILITY > Remote Ctrl > Device > GPIB

- **Server**

DL750 series, DL1600 series, DL1700E series, DL7400 series:

MISC > Network > TCP/IP Setup

DL9000 series, SB5000 series:

SYSTEM > Network > TCP/IP Setup > Configuration

SL1400:

MENU > Network > TCP/IP Setup

SL1000:

DISPLAY key (Displays the communication parameter screen)

DLM2000 Series, DLM3000 Series, DLM4000 Series, DLM5000 Series:

UTILITY > Network

DL6000/DLM6000 Series:

UTILITY > Network > TCP/IP Configuration

DL850 series:

UTILITY > Network > TCP/IP

DL350 series:

UTILITY > Network > TCP/IP

- **User Name (for the Network interface)**

DL750 series, DL1600 series, DL1700E series:

MISC > Remote Cntl > User Account

DL7400 series:

MISC > Remote Control > User Account

DL9000 series, SB5000 series:

SYSTEM > Remote Control > Network (User Name/Password)

SL1400:

MENU > Remote Cntl > User Account

DL6000/DLM6000 Series:

UTILITY > Network

DL850 series:

UTILITY > Network

DL350 series:

UTILITY > Network

- **Serial No. (for the USB interface with the DL9000/SB5000 series, or SL1000, DLM2000 series, DLM4000 series, DLM4000 series, DLM5000 series, DL6000/DLM6000 series, DL850 series, or DL350 series)**

DL 9000 series, SB5000 series:

SYSTEM > Overview

SL1000:

The number (instrument number) marked on the name plate of the SL1000.

DLM2000 Series, DLM3000 Series, DLM4000 Series, DLM5000 Series:

UTILITY > Overview

DL6000/DLM6000 Series:

UTILITY > Overview

DL850 series:

UTILITY > Overview

DL350 series:

UTILITY > Overview

8.1 Connecting to the Instruments

- **“unknown” Model Name Display**

Once you have made the connection settings and, using those settings, a connection is made successfully, the “model name” of the connected device will appear under Model in the Communication Setting dialog box. If a connection cannot be established, however, an error message is displayed and “unknown” appears as the model name.

- **Firmware Versions**

Xviewer may not be able to establish a connection with the instrument, depending on the firmware version of the software installed in that unit. Xviewer is compatible with the following firmware versions.

DL750 series:	Firmware versions 2.50 and later
DL1600 series:	Firmware versions 1.12 and later
DL7400 series:	Firmware versions 1.23 and later
DL1700E series:	All firmware versions
DL9040/DL9140/DL9240 series:	Control Inst is supported by firmware versions 1.64 and later. DL file display and transfer as well as load and save are supported by firmware versions 1.8 and later.
DL9500/DL9700 series:	All firmware versions
SB5000 series:	All firmware versions
SL1400:	All firmware versions
SL1000:	All firmware versions
DLM2000 series:	Control Inst, load and save, and DLM file display and transfer (USB upload and GP-IB download) are supported by firmware versions 1.06 and later. DLM file display and transfer (USB download and VXI-11 download) are supported by all firmware versions.
DL6000/DLM6000 Series:	All firmware versions
DL850 series:	All firmware versions
DLM3000 series:	All firmware versions
DLM4000 series:	All firmware versions
DLM5000 series:	All firmware versions
DL350 series:	All firmware versions

8.2 Displaying a File List

Procedure

Displaying a File List

On the **Xviewer tool bar**, click **Open Inst** to open the Communication Setting dialog box. Select the required instrument and then click **Connect** to establish the connection with the instrument and display a file list.

Note

- If a connection has already been established with the required instrument, the Communication Setting dialog box does not appear and the file list appears immediately.
- When you click Control Inst to enable operation of the instrument from a PC, Open Inst is grayed out.
- If the instrument contains a very large number of files, it may take some time for the file list to appear.

Changing the Order of/Updating the File List

When you click **Name**, **Size**, **Type**, or **Last Write Time** in the file list, the file list is sorted based on that clicked item. Clicking **Refresh** on the tool bar causes the file list to be refreshed based on the latest information.

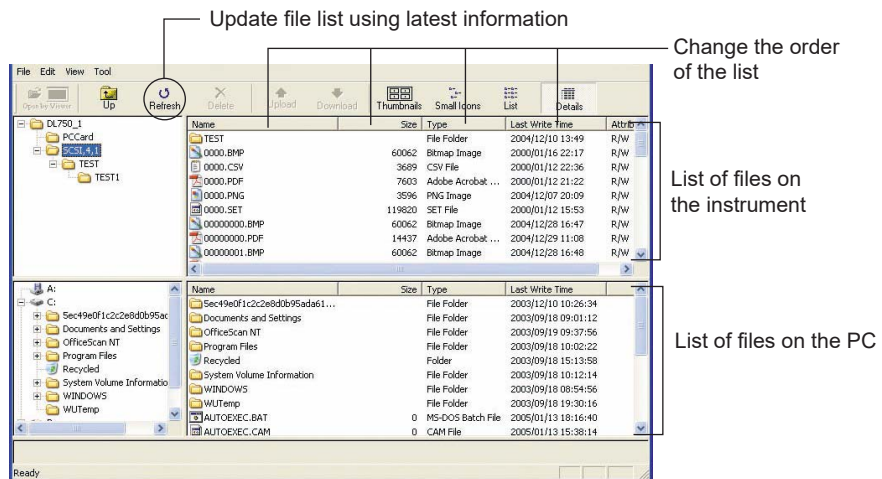

8.2 Displaying a File List

Thumbnailing Image Files

Clicking **Thumbnails** on the tool bar causes the image files stored on the instrument to be displayed as thumbnails.

Note

- Files other than image files will be displayed as icons.
- Those image files for which there is no thumbnail file to display will be displayed as icons.

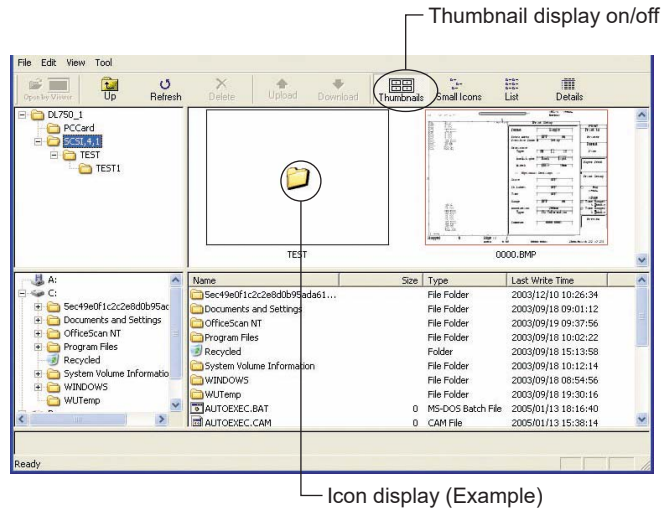

Changing the Size of the Displayed Thumbnails

Select **Tool > Options** on the file list menu bar to display the Option dialog box. Select a size for the thumbnails (width and height), and then click **OK**.

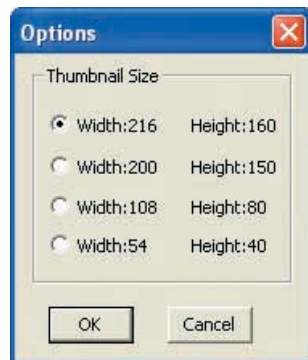

Explanation

Displaying Realtime Recording Data

For the DL750/DL750P and SL1400

On the SL1400 and DL750/DL750P with firmware version 6.01 or later, the file list of the [SCSI,4,0] folder on the DL750/DL750P/SL1400 can be displayed. The [SCSI,4,0] folder contains data that has been real-time recorded on the DL750/DL750P/SL1400 (.wdf data).

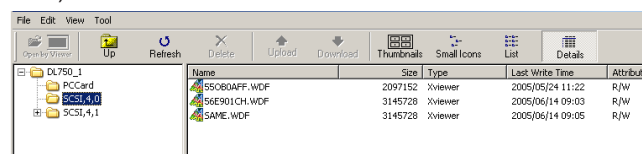

For the SL1000, DL850 series and DL350 series

If files were recorded in real time on the SL1000, DL850 series or DL350 series and divided into multiple files, only the first file (***_000.WDF) is displayed.

8.3 Manipulating Files

Procedure

Downloading from the Instrument to the PC

If you select a file from the list of files stored on the instrument, Download is enabled. If you then click **Download**, the selected file is transferred to the PC.

Note

- Multiple files can be specified for transfer.
- While files are being transferred, the connection to the instrument cannot be terminated.
- With the DLM2000 series, DLM3000 series, DLM4000 series, and DLM 5000 series, if waveform acquisition is in progress, you must stop waveform acquisition before performing file operations such as uploading of files to the DLM2000, DLM3000, DLM4000, and DLM 5000, downloading of files to the PC, deletion of files, deletion of folders, and creation of new folders.
- If files were recorded in real time on the SL1000, DL850 series or DL350 series and divided into multiple files, all divided files are downloaded when you download the displayed first file (****_000.WDF).

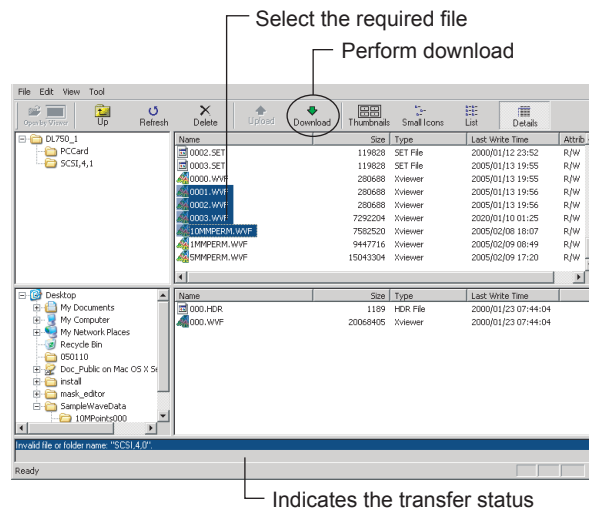

Uploading from the PC to the Instrument

If you select a file from the list of files stored on the PC, Upload is enabled. If you then click **Upload**, the selected file is transferred to the instrument.

Note

- Files can be transferred from the PC to the instrument (upload) only when the USB interface is being used for the connection. However, if the product version is version 1.78 or later, Ethernet can also be used to connect to a DL850 series, DL350 series, DL4000 series, or DLM5000 series.
- Multiple files can be specified for transfer.
- While files are being transferred, the connection to the instrument cannot be terminated.
- The data in the [SCSI,4,0] folder in which the realtime recording data (DL750 series and SL1400) can be downloaded to the PC. However, you cannot create a directory in the folder or upload data to the folder.
- With the DL9000 series, SB5000 series, and DL6000/DLM6000 series files cannot be uploaded to a USB memory connected to the instrument.
- If files were recorded in real time on the SL1000, DL850 series or DL350 series and divided into multiple files, all divided files are uploaded when you upload the displayed first file (****_000.WDF).

8.3 Manipulating Files

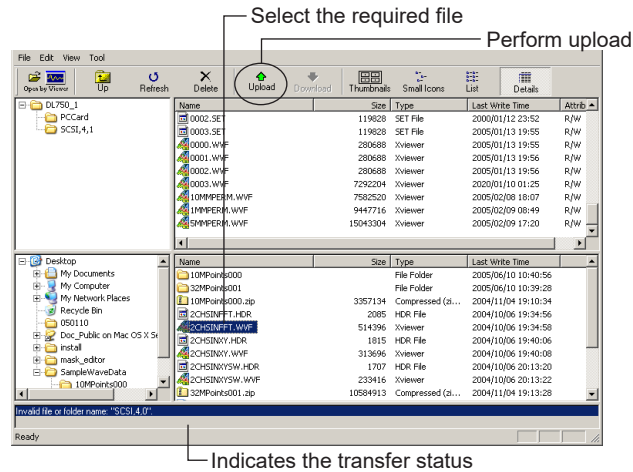

Deleting a File

If you select a file from the file list and then click **Delete**, the selected file is deleted.

Note

- When you delete an image file, the corresponding thumbnail file is deleted at the same time.
- A folder cannot be deleted.
- If files were recorded in real time on the SL1000, DL850 series or DL350 series and divided into multiple files, all divided files are deleted when you delete the displayed first file (****_000.WDF).

Deleting a Folder (SL1000)

With the SL1000, If you select a folder from the file list and click Delete, the selected folder is deleted.

Note

If you delete a folder, all files within the folder are also deleted at the same time.

Reading a Waveform Data File

If you select a WVF-format waveform data file (*.wvf / *.wdf) from the file list on the PC, Open by Viewer is enabled. If you then click **Open by Viewer**, the selected file is read and the waveform data that it contains is displayed in the Viewer window. Display required file (waveform data) in the Viewer window

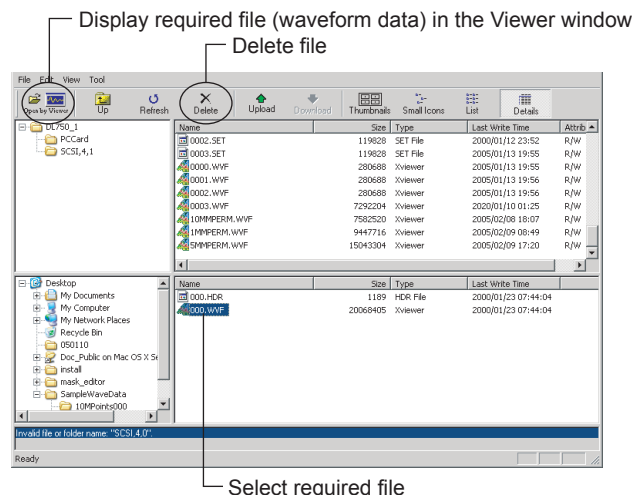

Creating a Folder

Select **Tool > New Folder** on the file list menu bar to display the folder creation dialog box. Input a name for the new folder, and then click **OK**.

Note

- The new folder will be created under the current directory of the file list.
- For the folder name and upload file name, you can specify ASCII characters (alphanumerics, etc.) only.

Explanation

Cautions to Observe When Transferring a Waveform Data File

A WVF-format waveform data file (*.wvf) cannot be opened unless there is an .hdr file with the same name in the same folder. Therefore, when transferring a WVF-format file, be careful to also transfer the corresponding .hdr file.

Note

Right click the files selected to be manipulated, and select one of the following from the shortcut menu.

Download: Available when the instrument internal files or folders are selected

Upload: Available when PC files or folders are selected

Delete: Available when a file is selected
(With the SL1000, you can also select and delete a folder.)

Create folder: Available whether a file, folder, or nothing is selected
The following folder names cannot be used.

AUX, CON, PRN, NUL, CLOCK, COM0 to COM9, and LPT0 to LPT9

Update to Latest Information: Available whether a file, folder, or nothing is selected

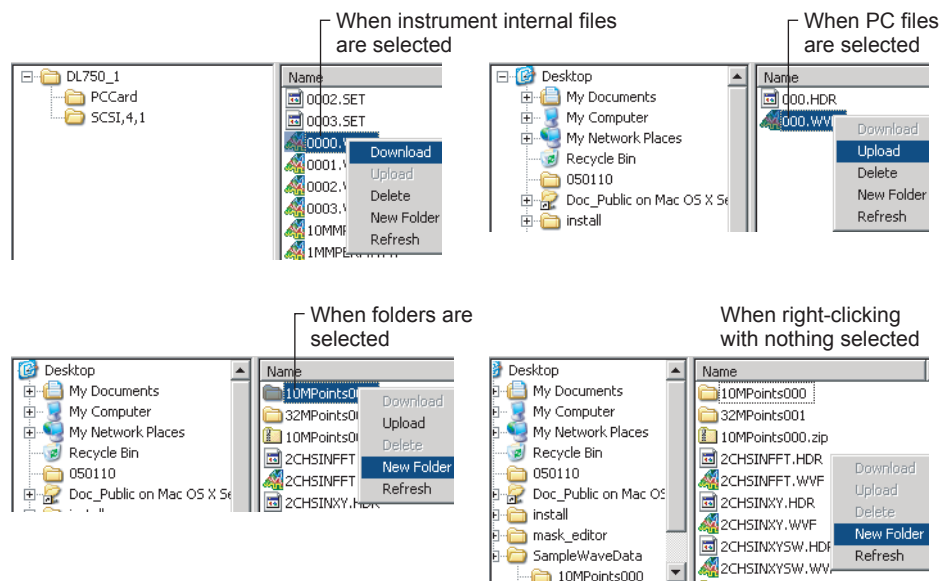

8.4 Operating the Instruments from a PC

DL750 Series, DL1600 Series, DL1700E Series, DL7400 Series, SL1400 Procedure

Displaying the Control Screen

Click **Control Inst** on the **Xviewer tool bar** to display the Communication Setting dialog box. If you then select the required instrument and then click **Connect**, a connection with the instrument is established and the control screen (an image of the front panel) appears.

Note

- If a connection has already been established with the required instrument, the Communication Setting dialog box does not appear and the control screen appears immediately.
- When you click Open Inst to display a list of files on the instrument, Control Inst is grayed out.

Controlling the Update of the Display

Click **UPDATE** on the control screen to forcibly update the control screen display. If you click **PAUSE**, the update of the control screen is stopped temporarily. Clicking **PAUSE** again restarts the update of the screen display.

Operation of the Control Screen

The control screen allows you to operate or control a DL unit using the PC's mouse or keyboard.

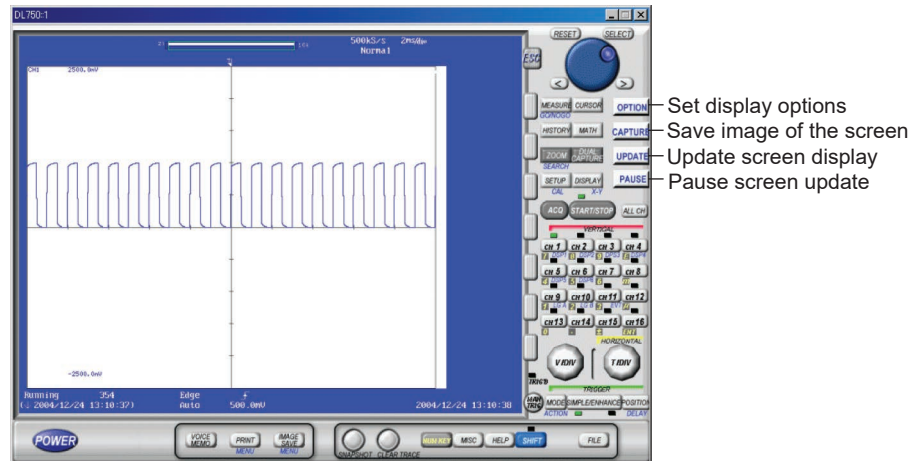

Setting Screen Display Options

Click **OPTION** on the control screen to display the Option dialog box. Set the control screen display size, the refresh rate, and display brightness, and then click **OK**.

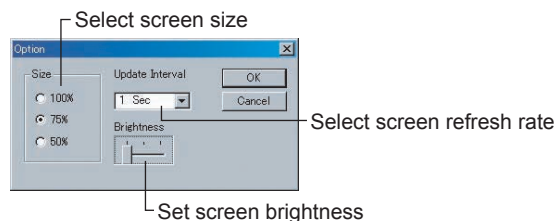

Saving an Image of the Screen

Click **CAPTURE** on the control screen to display the file save dialog box. Select the folder into which you want to save the file, specify the file name, select a save color and then click **OK**.

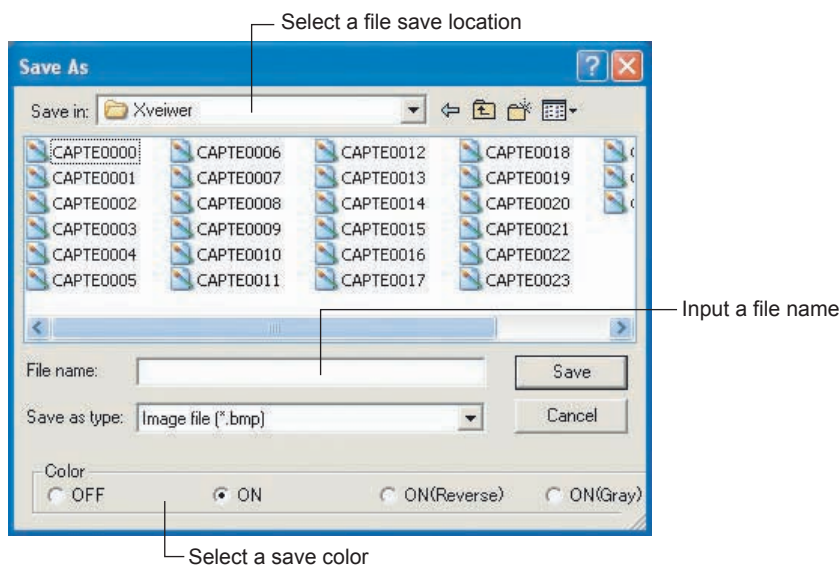

Note

Press the SHIFT key (keyboard) and click the CAPTURE button (control screen) to copy the screen to the clipboard.

Explanation

Option Settings

The following settings can be made for the screen display options.

- **Display size (Size):** Select 100%, 75%, or 50%
- **Display refresh rate (Update Interval):** Select 1 sec, 2 sec, 5 sec, 10 sec, 30 sec, 1 Min, 5 Min, 10 Min, 20 Min, 30 Min, 1 hr, or Minimum
- **Brightness (Brightness):** Adjust using the slide bar

Note

- Depending on the network transmission method or the communications load, the actual display refresh rate may be slower than the set value.
- When you select **Minimum** for the screen refresh rate, the fastest possible refresh rate for your environment is set automatically. Note that if the connection to the instrument is made via a network, the network load may affect the refresh rate.

Using the Display Update Button

- The UPDATE button is used to forcibly refresh the display when, for example, a slow refresh rate has been set or refresh has been temporarily stopped (when the PAUSE button is available).
- The PAUSE button is used to temporarily stop refresh when the ON/OFF settings of many items must be changed, values must be entered using the keyboard, or when better system response is needed.

Screen Image Save Format

When you click the CAPTURE button to save a screen image, an image of the currently displayed screen is saved as a BMP-format file.

Screen Image Save Color

When you save a screen image, you can select and of the following colors.

- **OFF:** Screen image is saved in monochrome
- **ON:** Screen image colors are saved as is
- **ON (Reverse):** Other than the channel colors are saved in monochrome
- **ON (Gray):** Other than monochrome colors are saved as grays

Using the Mouse

If you position the mouse cursor to a control key or knob on the control screen, the mouse pointer (icon) changes, indicating that key or knob on the screen can be operated. The displayed icon and the action of the mouse changes depending on where on the control screen it is positioned.

Mouse Pointer Position	Displayed Icon & Mouse Action	Setting Operation
Operation key	Click	Same as pressing an operation key
Soft key menu or dialog box	Click Wheel	Same as pressing a soft key or a button Same as turning the jog shuttle
Voltage axis information display area	Click Wheel	Same as pressing a channel key Same as turning the V/DIV knob
Time axis information display area	Click Wheel	Same as turning the T/DIV knob
Jog shuttle left- and right-hand areas	Click Wheel	Same as turning the jog shuttle to the left of the right Same as turning the jog shuttle
V/DIV knob left- and right-hand areas	Click Wheel	Same as turning the V/DIV knob to the left or the right Same as turning the V/DIV knob
T/DIV knob left- and right-hand areas	Click Wheel	Same as turning the T/DIV knob to the left or the right Same as turning the T/DIV knob

Example of Using the Control Screen

Using the Operation Keys

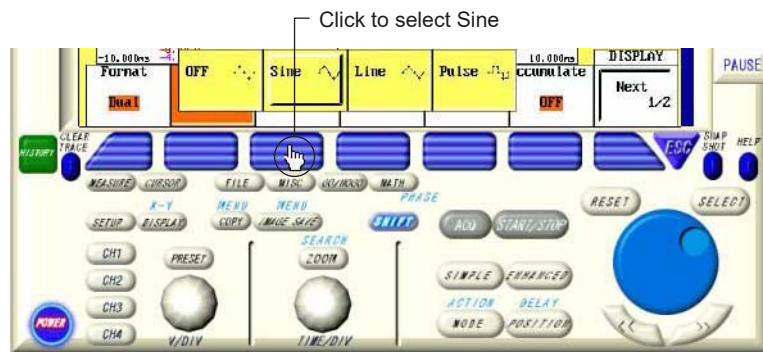

Soft Key Menu Operation

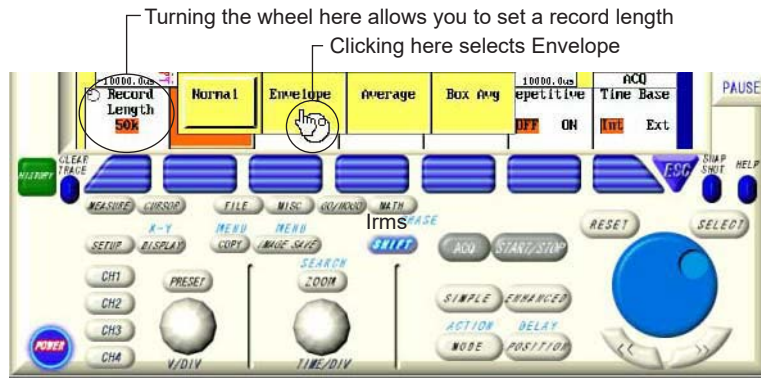

Jog Shuttle Operation

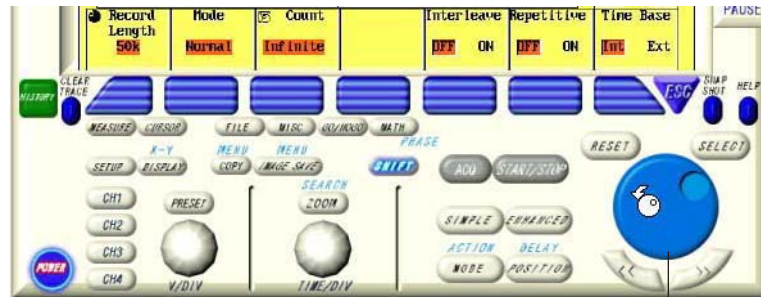

V/DIV Knob Operation

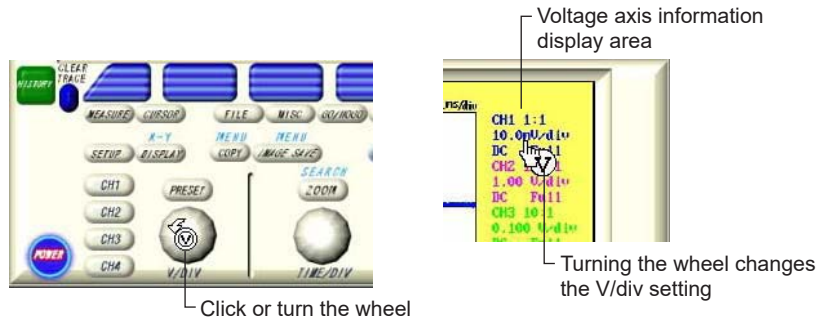

T/DIV Knob Operation

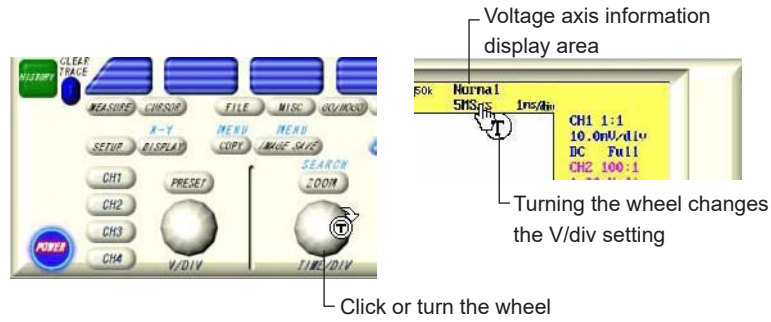

Dialog Box Operation

- **Position the mouse cursor to the item you want to turn ON:**
Click the **jog shuttle** or turn the wheel
- **ON/OFF setting:** Click **SELECT** or click the item directly, as shown below



DL9000/SB5000/DLM2000/DLM4000/DLM5000/DL6000/DLM6000/DL850/DL350 series**Procedure****Displaying the Control Screen**

Click **Control Inst** on the **Xviewer tool bar** to display the Communication Setting dialog box. If you then select the required instrument and then click **Connect**, a connection with the instrument is established and the control screen (an image of the front panel) appears.

Note

- If a connection has already been established with the required instrument, the Communication Setting dialog box does not appear and the control screen appears immediately.
- When you click Open Inst to display a list of files on the instrument, the “Control Inst” is grayed out.
- In the following cases, the control screen display cannot be updated:
 - While editing waveform, square, or polygon zones
 - During processing of cycle statistics
 - During statistical processing of history data
- In the following cases, the control screen display cannot be updated:
 - While editing waveform, square, or polygon zones
 - During processing of cycle statistics
 - During statistical processing of history data

Controlling the Update of the Display

Choose **Menu > View > Update** in the control screen to force an update of the control screen. Choose **Menu > View > Pause** to pause updating of the control screen. To restart display updating, choose **View > Pause** again.

Operation of the Control Screen

The control screen allows you to operate or control the instrument using the PC's mouse or keyboard. On the control screen of the DL350 and DLM3000 series, you can click the parts on the screen with a mouse or a similar device to perform the same operations as using the touch panel.

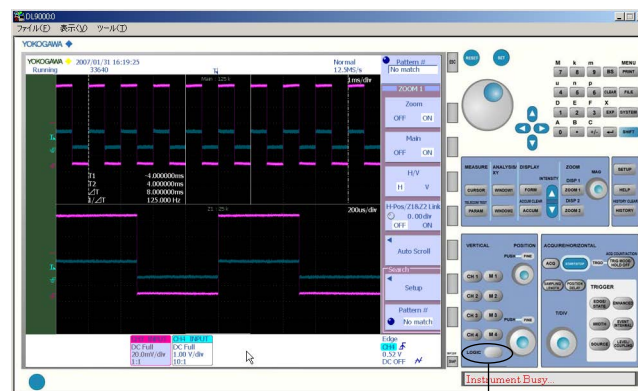
DL9000 Series

The LOGIC button is displayed for the DL9500/DL9700

SB5000 series

Series or SB5000 series.

8.4 Operating the Instruments from a PC

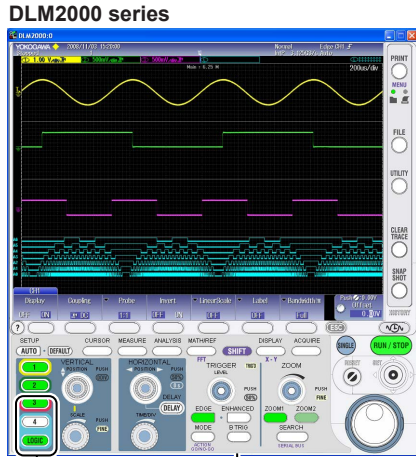

English panel sheet

Displayed on 4-channel models and models with a logic input terminal.

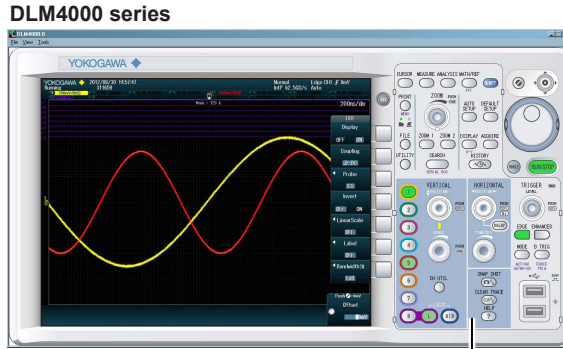

English panel sheet

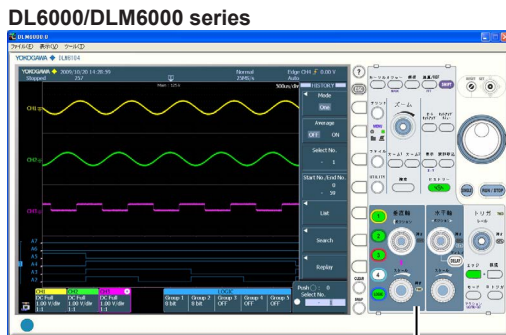

English panel sheet

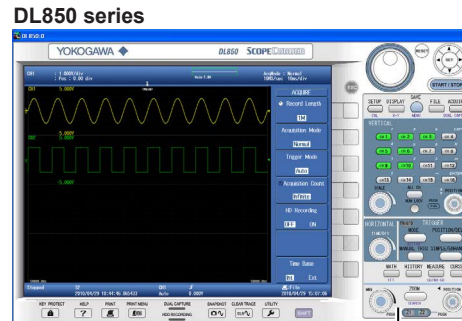

English panel sheet

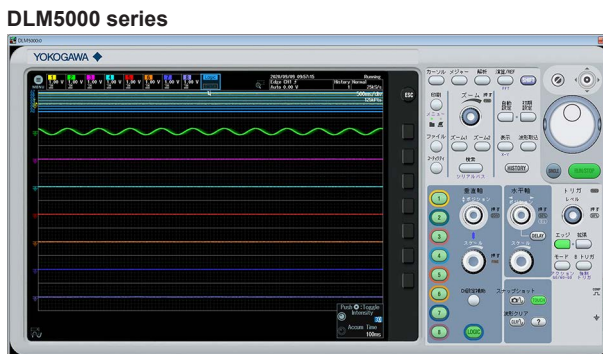
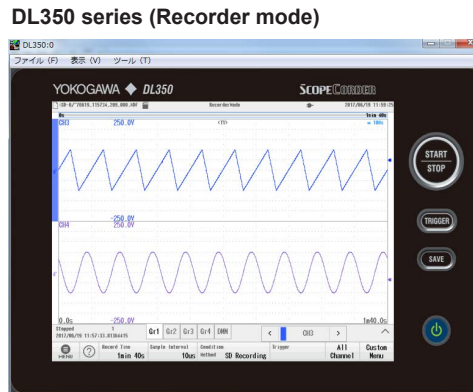
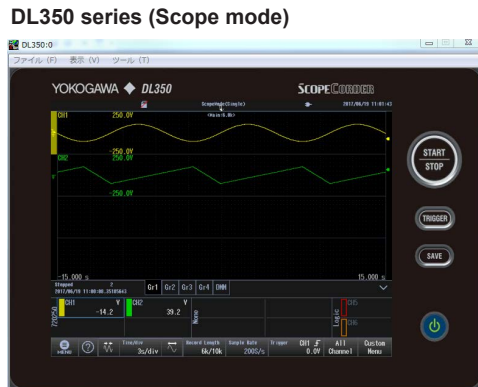

Note

- Do not connect from the PC while hard disk recording is occurring on the DL850 series.
- When controlling the DL850 series from the PC, do not start hard disk recording on the DL850 series. Doing so can overload the DL850 series internal processing, resulting in malfunction.
- Auto setup cannot be executed on the DLM5000 series serial bus using Control Inst on the Xviewer toolbar.

Screen Display Size

Choose **Menu > View > Zoom > Smaller, Standard, or Larger**. The control screen changes to the selected size.

Copying the Image to the Clipboard

Select **Tool > Copy Image to Clipboard** or **Copy Image to Clipboard (Reverse)**.

- Copy Image to Clipboard
The image of the display section of the control window is copied to the clipboard.
- Copy Image to Clipboard (Reverse)
The image of the display section of the control window is copied to the clipboard without the background color.

Saving an Image of the Screen

Choose **Menu > File > Save > Image** in the control screen to display the file save dialog box. Select the folder into which you want to save the file; specify the file name, save as type, and color; and then click **Save**.

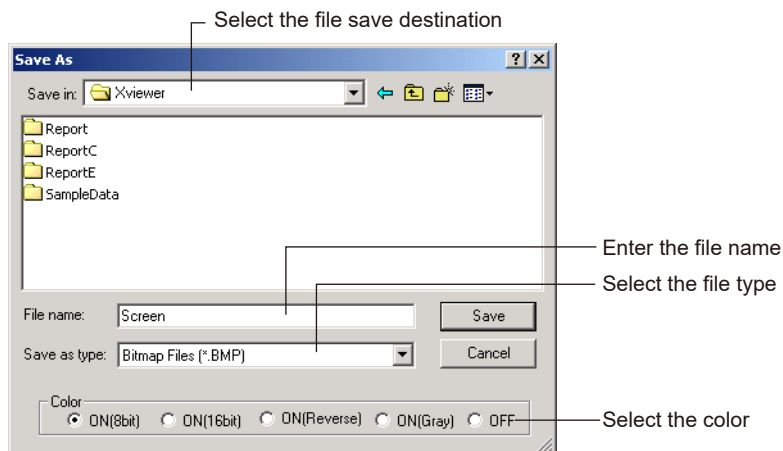

Explanation

Screen Display Size

You can select the zone from below.

Smaller, standard, larger

Display Update Interval

You can select the zone from below.

100 ms, 200 ms, 300 ms, 500 ms, 1 s, 2 s, 5 s, 10 s

Note

- Depending on the network transmission method or the communications load, the actual display update interval may be slower than the set value.
- With the DLM2000 series, the image on the PC may be disrupted immediately after transferring waveform screens or saving screen images. This does not affect the data. The image will recover automatically after the next screen update.

Display Update Operation Control

- Forced updating is used when setting a slow display update rate or when pausing display updating (by choosing Menu > View and selecting Pause).
- Pause is used to improve the response when turning many items ON/OFF at once, or when entering numerical and other values with the keyboard.

Screen Image Save Format

An image of the currently displayed screen is saved as a BMP-format file.





Selecting the Color Mode

You can select the color mode. The selectable color modes vary between BMP and PNG formats.







- **BMP:** 8 bit, 16 bit, reverse, grayscale, and color OFF (black and white)
- **PNG:** 16 bit, reverse, grayscale, and color OFF (black and white)

Using the Mouse

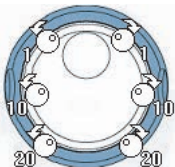
If you position the mouse cursor to a control key or knob on the control screen, the mouse pointer (icon) changes, indicating that key or knob on the screen can be operated. The displayed icon and the action of the mouse changes depending on where on the control screen it is positioned.

Mouse Pointer Position	Displayed Icon & Mouse Action	Setting Operation
Operation key	 Click	Same as pressing an operation key
Rotary-knob left- and right-hand areas	 Click Wheel	Same as turning the rotary knob to the left of the right Same as turning the rotary knob
Center of POSITION, SCALE knob	 Click Wheel	Same as pushing the POSITION knob or SCALE knob
POSITION, SCALE, T/DIV, and MAG knob left- and right-hand areas	 Click Wheel	Same as turning the POSITION, SCALE, T/DIV, and MAG knob to the left or the right Same as turning the POSITION, SCALE, T/DIV, and MAG knob

**DLM2000 Series, DLM3000 Series, DLM4000 Series, DLM5000 Series,
DL6000/DLM6000 Series, DL850 series**

Mouse Pointer Position	Displayed Icon & Mouse Action	Setting Operation
Operation Key	 Click	Same as when pressing a key.
Around the left or right side of the jog shuttle	 Click Wheel	Same as turning the jog shuttle to the left or right. The setting can be changed at a setting resolution of 1, 10, or 20 times depending on the location of the mouse pointer. Hold down the mouse button to change the setting repeatedly. Same as turning the jog shuttle.
Center of POSITION, SCALE, TRIGGER LEVEL, or ZOOM knob	 Click	Same as pushing the corresponding knob.
Around the left, right, or bottom of POSITION or TRIGGER LEVEL knob	 Click Wheel	Same as turning the corresponding knob to the left or right. The setting can be changed at a setting resolution of 1 or 10 times depending on the location of the mouse pointer. If you click in the bottom area where the number 123 appears, an input box is displayed for direct input of a setting value. Hold down the mouse button to change the setting repeatedly. Same as turning the corresponding knob.
Around the left or right of SCALE, TIME/DIV, or ZOOM knob	 Click Wheel	Same as turning the corresponding knob to the left or right. The setting can be changed at a setting resolution of 1 time. Same as turning the corresponding knob.
Center of the SET key	 Click	Same as pressing the SET key.
Around the left, right, top, or bottom of the SET key	 Click	Same as pushing the SET key in the direction of the arrow.

**Example of Using the Control Screen
Using the Operation Keys**

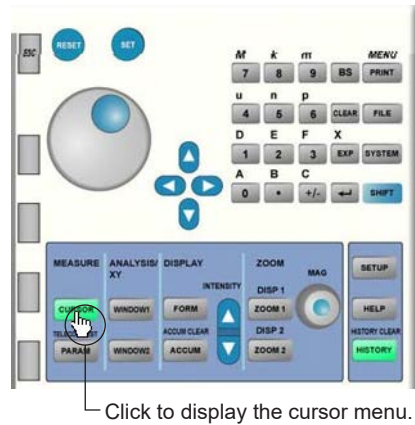

Rotary Knob Operation

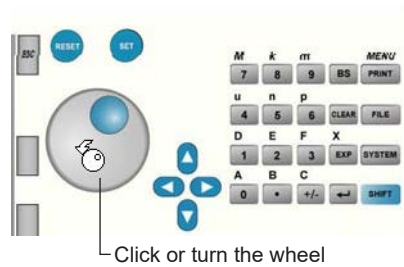

T/DIV Knob Operation

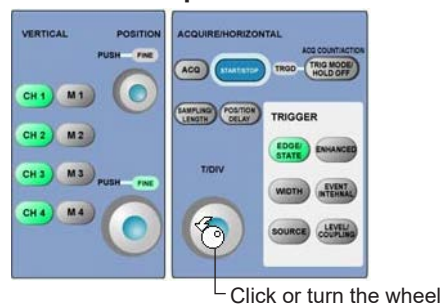

SCALE Knob Pushing Operation

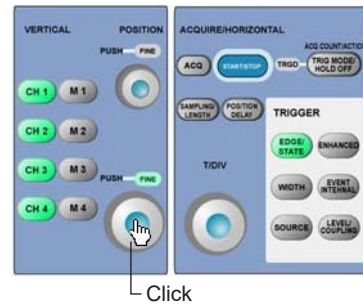

Note

- If you hold down the ctrl key and right click in the control screen, you can select from the following settings menu.
 - Save (Image, Waveform)
 - Zoom (Smaller, Standard, Larger)
 - Pause
 - Update
 - Options

8.5 Downloading the Instruments Waveform Data

DL750 Series, DL1600 Series, DL1700E Series, DL7400 Series, SL1400

Procedure

Click **ACQ save** on the Xviewer toolbar. A control screen and file save dialog box open. If the connection with the instrument is not established, the Communication Setting dialog box opens. Establish a connection with the instrument according to the operations given in section 8.1.

Saving the Waveform Data

Set the destination and file name and click **OK**. The extension is **.wvf**.

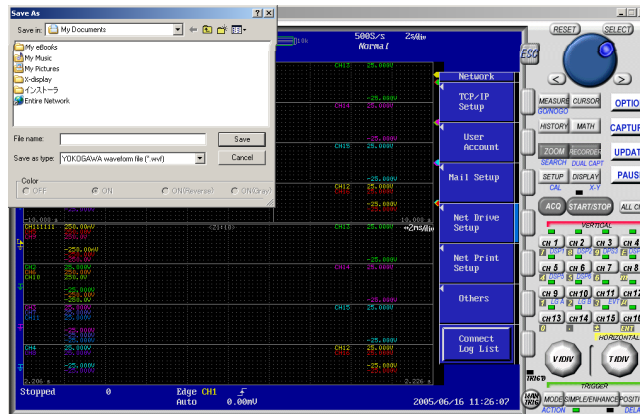

Explanation

Waveform data can be downloaded (saved) to the PC.

Click **CAPTURE** on the control screen to display the file save dialog box. Set Save as type to ***.wvf**, specify the file name, and select Save to download (save) the waveform data.

Waveforms That Are Saved

All waveforms including computed waveforms displayed on the control screen are saved. However, if multiple history waveforms are displayed with the history memory function, only the waveform selected with Select Record is saved.

Applicable Models

- DL750 series (firmware version 6.01 or later)
- DL1600 series (firmware version 1.30 or later)
- DL1700E series (software version 2.11 or later)
- DL7400 series (software version 2.11 or later)
- SL1400

Note

- If the data compression setting of the instrument (P-P Comp, Decim, etc.) is ON, turn data compression OFF before saving the waveform data.
 - On the DL1600 series, waveform data cannot be downloaded if the record length is greater than or equal to 8 MW.
 - When multiple history waveforms are displayed, the instrument settings are changed when downloading is executed as follows:
 - DL750 series, DL7400 series, and SL1400: HISTORY > DisplayMode > One
 - DL1600 series and DL1700E series: HISTORY > Display > One
 - Sub waveforms acquired using the dual capture function on the DL750 are not saved.
 - DL9000 series (firmware version 1.80 and later)
 - SB5000 series
 - DLM2000 series (firmware version 1.06 and later)
-

DL9000/SB5000/DLM2000/DLM3000/DLM4000/DLM5000/DL6000/DLM6000/DL850/DL350 series

Procedure

Click **ACQ save** on the Xviewer toolbar. A control screen and file save dialog box open. If the connection with the instrument is not established, the Communication Setting dialog box opens. Establish a connection with the instrument according to the operations given in section 8.1.

Saving the Waveform Data

Set the destination and file name and click **OK**. The extension is .wdf.

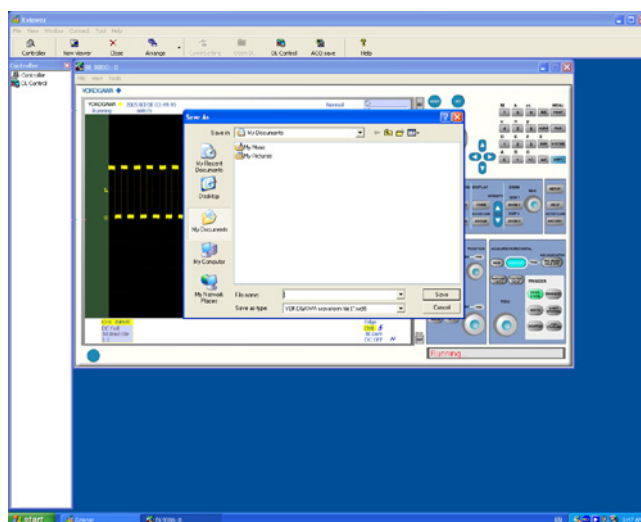

Explanation

Waveform data can be downloaded (saved) to the PC.

From the **File** menu on the control screen, point to **Save** and choose **Waveform** to display the file save dialog box. Set Save as type to *.wdf, specify the file name, and select Save to download (save) the waveform data.

Waveforms That Are Saved

All waveforms including computed waveforms displayed on the control screen are saved.

Applicable Models

- DL9000 series (firmware version 1.80 or later)
- SB5000 series
- DLM2000 series (firmware version 1.06 or later)
- DL6000/DLM6000 series
- DL850 series
- DLM3000 series
- DLM4000 series
- DLM5000 series
- DL350 series

Note

The image on the PC may be disrupted immediately after downloading waveform data. This does not affect the data. The image will recover automatically after the next screen update.

9.1 Troubleshooting

Problem	Probable Cause/Corrective Action
An error occurs when installing	Another version of Xviewer is already installed. Uninstall the other version of Xviewer, then reinstall.
Xviewer cannot communicate with the instruments	The GP-IB, USB or Ethernet interface cable is incorrectly connected Connect the cable correctly. The address specified for the GP-IB interface is incorrect. The ID of the USB interface might be set incorrectly. The serial number of the USB interface might be set incorrectly. A USB driver might not be installed. The IP address, subnet mask, and default gateway of the Ethernet interface might not be set correctly. The VXI11 check box might not be selected.
A file cannot be opened	A .hdr file having the same name as the file you are trying to open is not present in the same folder. Place the header file in the folder. The file is not of a type that the instrument Xviewer can handle.
A trace name is incorrectly displayed	If a trace name includes a space, it may not appear correctly.
A voice memo cannot be played back	Your PC does not support audio playback Use Xviewer on a PC with sound capabilities.
Comments in files saved on the DL750 series are not displayed	DL750.dll does not exist in the folder in which Xviewer is installed, or an old version of DL750.dll exists Install the latest version of DL750.dll(see page 2-3).
The Yokogawa web page is inaccessible	Your PC is connected with the Internet.
A message stating "Insufficient memory. Terminate any unnecessary applications." appears.	There is insufficient memory Reduce the number of waveforms to be loaded, or terminate another application.
I cannot load files that were recorded in real time on the SL1000, DL850 series or DL350 series.	You may be specifying a divided file from real-time recording other than the first file. Try loading the first file (****_0000.WDF).

Note

For up-to-date information on the Xviewer, check the YOKOGAWA Web page (see section 9.4).

9.2 Viewing Version Information

Procedure

Select **Help > About Xviewer** The version of Xviewer you are currently using is displayed.

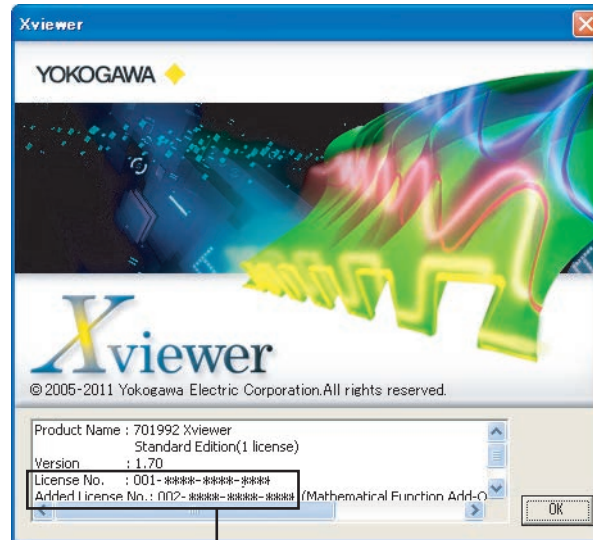

Displays the version information including the added license number

9.3 Starting Online Help

Procedure

Click  or choose **Help > Help > User's Manual** on the tool bar. If Acrobat Reader is installed in the PC, it launches, and a pdf file of this instrument's user's manual is displayed.

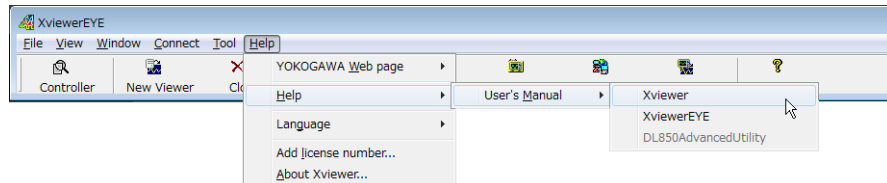

Explanation

Online Help

You can display a pdf file of this instrument's user's manual. If a notice of alteration has been made, you can display a pdf of the notice by choosing **Help > Help > Notice of Alteration** from the tool bar.

Note

Adobe Reader by Adobe Systems is required to open PDF files. You can download Adobe Reader from the following Web page.

<http://www.adobe.com/products/acrobat/readstep2.html>

9.4 Visiting the Yokogawa Web Page

Procedure

Select **Help > YOKOGAWA Web Page > Test & Measurement**, or **Help > YOKOGAWA Web Page > Xviewer** to access our web page.

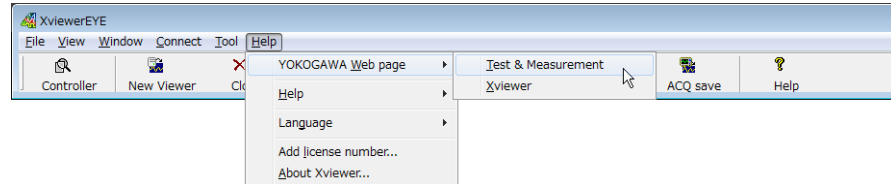

Explanation

When your PC is connected to the Internet, you can visit our web page.

Test & Measurement: Displays our Test & Measurement top page.

Xviewer: Displays the Xviewer page. Up-to-date information such as updates on the Xviewer is provided.

9.5 Adding a License Number

Procedure

You can update the standard version of Xviewer by adding the license for the Xviewer Math Edition.

701992 Xviewer (latest standard version after version 1.31) must be installed before installing the Computation Function Setup Upgrade Version.

If the version of Xviewer that you are using is old, uninstall it and then install the latest Xviewer.

Note

- For the installation and uninstallation Procedures, see page xii.
- To check the version, see section 9.2, "Viewing Version Information."

1. Start Xviewer (standard version) that is already installed.
2. Select **Help > Add licenseNo**. The dialog box for registering the license number opens.
3. Enter the number indicated on the license label, and click **Add**. If the upgrade completes successfully, a message appears prompting you to restart Xviewer.
4. Click **OK**.
5. Restart Xviewer.

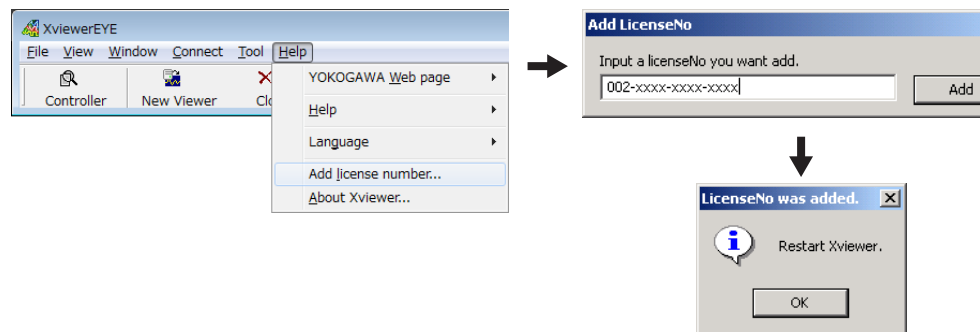

6. Select **Help > About Xviewer**. Check the version information. For details, see section 9.2.

10.1 Applicable Models and Features

Models from which Xviewer can load waveform data:

Model	File Types (filename extension)				
	CSV ¹ (.csv)	WVF ² (.wvf)	WDF ² (.wdf)	WDF ³ (.wdf)	MAT ⁴ (.mat)
WE7000		Yes	No	No	No
DL1700 series	Yes	Yes	No	No	No
DL1600 series	Yes	Yes	No	No	No
DL1700E series	Yes	Yes	No	No	No
DL7400 series	Yes	Yes	No	No	No
DL750 series	Yes	Yes	No	Yes	No
DL9040/DL9140/DL9240 series	Yes	No	Yes	No	No
DL9500/DL9700 series	Yes	No	Yes	No	No
DL6000/DLM6000 series	Yes	No	Yes	No	No
SB5000 series	Yes	No	Yes	No	No
SL1000	No	No	Yes	Yes	No
SL1400	Yes	Yes	No	Yes	No
DLM2000 series	Yes	No	Yes	No	No
DLM3000 series	Yes	No	Yes	No	No
DLM4000 series	Yes	No	Yes	No	No
DLM5000 series	Yes	No	Yes	No	No
DL850 series	Yes	No	Yes	Yes	Yes
DL350 series	Yes	No	Yes	No	Yes

1 Files created and saved in ASCII format

2 Files created and saved in binary format

3 Files created with real-time recording

4 Files saved as MATLAB format

- Files containing measured waveform data saved with this software in binary format (.wdf files)

Models and Available Communication Functions:

Model	Communication Function		
	Viewing and Transferring Files	Remote Control	Downloading Acquisition Data
WE7000	No	No	No
DL1700 series	No	No	No
DL1600 series	Yes	Yes	Yes
DL1700E series	Version 1.12 or later	Version 1.12 or later	Version 1.30 or later
DL7400 series	Yes	Yes	Yes
DL750 series	Version 1.23 or later	Version 1.23 or later	Version 2.11 or later
SL1400	Yes	Yes	Yes
DL9040/DL9140/DL9240 series	Yes	Yes	Yes
DL9500/DL9700 series	Version 1.80 or later	Version 1.64 or later	Version 1.80 or later
SB5000 series	Yes	Yes	Yes
SL1000	Yes	No	No
DLM2000 series	Yes	Yes	Yes
DL6000/DLM6000 series	Yes	Yes	Yes
DL850 series	Yes	Yes	Yes
DLM4000 series	Yes	Yes	Yes
DL350 series	Yes	Yes	Yes
DLM3000 series	Yes	Yes	Yes
DLM5000 series	Yes	Yes	Yes

10.1 Applicable Models and Features

Available Functions

- Main waveform view, zoom waveform view, history waveform view, X-Y waveform view, and measurement result view
- Measurements with vertical/horizontal/X-Y cursors
- Waveform parameter automatic measurement/computational measurement (optional)/ Insertion of annotations
- Multiple files conversion (wdf to wvf, wvf/wdf to csv)
- Saving and printing of the data
- Play back of voice memos saved with the DL750 series

10.2 System Environment Requirements

Operating System	
	Microsoft Windows 8, Windows 8.1, and Windows 10
PC Hardware	
CPU	Core 2 Duo, 2 GHz or better
Memory	1 GB or more (2GB recommended)
Space available on HDD	Free space equaling 2 GB + the size of files to be loaded
Peripherals	
Display	XGA or higher (Colors: 65536 or more)
Drive	CD-ROM drive, mouse, and printer
Communication interface	GP-IB ¹ /USB ² /Ethernet
GP-IB Board or PCMCIA Card	GP-IB board made by National Instruments Corporation or PCMCIA card ³
Sound capabilities	Required to play back voice memos.

- 1 Not supported by the SL1000.
- 2 To use the USB interface, a dedicated USB driver is required.
- 3 The operation of the PCMCIA-GPIB card is not guaranteed on Windows 8, Windows 8.1, and Windows 10.

Required memory size (bytes)

The maximum required memory size for loading and displaying waveform data is 60 MB + 500 MB.

- * 500 MB is the maximum value for $12.5 \text{ Mpoints} \times \text{number of math channels} \times 4$. If the PC memory size is insufficient, decrease the number of math channels or add extra memory.

DPI setting

To display the characters correctly on Xviewer, you must set the "Display Properties" of Windows. In the Display Properties dialog box, click the Settings tab and click Advanced. Under the General tab, set the "DPI setting" to Normal size (96 DPI). The Font size setting under the Appearance tab in the Display Properties dialog box is irrelevant.

10.3 Software Versions and the Added Functions

The table below shows the software versions and the corresponding added functions. If the software is not of the newest version, you will not be able to use all the functions covered in this manual. Check the software version on the version information screen that appears by selecting **Help > Version**. For details on the procedure, see section 9.2.

Software Versions and the Main Functions That Have Been Added

Version	Added Function	Applicable Models	Reference Page/Section/Chapter
1.10 or later	Support for DL9000 ¹	DL9000 Series	Section 10.1
	ACQ save function (Downloads the DL acquisition data to the PC)	DL750 Series/ DL1600 Series ²	Section 8.4
	Log scale (Set vertical and horizontal axes when displaying the FFT waveform)	–	Page 3-9 and section 3.4
	Display the range over which FFT is performed and set the start point	All models ³	Section 4.6
	Display the computation start position marker and set the start point	All models ³	Page 4-19
	Analyze waveform data using H&V cursors	All models ³	Section 4.2
	File associations (wvf and wdf) (Double-click the file to start Xviewer)	–	Page 1-1
	Drag and drop CSV files on the viewer window	–	Page 2-4
	Restore the waveform color and the number of divided displays when the file is loaded ⁴	DL750 Series/ DL9000 Series	–
	1.20 or later	Supports the DL9000 ⁵	DL9000
ACQ save function (Downloads the DL acquisition data to the PC)		DL1700E/DL7400 series ⁶	Section 8.4
Copying of cursor/waveform parameter measurement results to the clipboard		–	Sections 4.2 and 4.3
Automatic display of the measurement results window		–	Section 4.1
Restored when loading waveform color, number of display divisions, and vertical axis upper and lower limit values ⁷		DL1600/DL1700E/ DL7400 series	–
Arrange Controller window/Xviewer tool bar/Viewer window		–	Section 1.2
Displays T/Div and V/Div on the waveform display window		–	Section 3.4
1.21 or later	Open DL, and ACQ save function (Displays and transfers DL files and downloads the acquisition data to the PC)	DL9000 series ⁸	Section 8.1, 8.2, 8.3, 8.7 and 10.1
1.30 or later	Supports the SL1400	SL1400	Section 10.1
	Report function Displays 0 level on the waveform display window	–	Chapter 7 Page 3-11
1.31 or later	Support for DL9710L.	DL9710L	Chapter 8
	Additional display format of the measured result (hexadecimal, Bundle display)	–	Page 3-5
	Additional Measure item (integration of the X-Y waveform)	–	Pages 4-8 and 4-9
	Horizontal zoom operation (expand or reduce at the clicked position and drag the window)	–	Section 2.6

(Continues to the next page)

10.3 Software Versions and the Added Functions

Version	Added Function	Applicable Models	Reference Page/ Section/Chapter
1.31 or later	Bit Label display and multiple vertical axes display added to the waveform display window	–	Page 3-11
	Edit function added to the report function (undo, redo, and grid display)	–	Section 7.2
	Save format of the screen image added in the DL control	–	Section 8.5
	Overlaying of the X-Y waveforms	–	Section 2.5
1.32 or later	Support for the DL1735E, DL9505L, DL9510L, and DL9705L.	DL1735E, DL9505L, DL9510L, DL9705L	–
	Changed button names (Open DL -> Open Inst., and DL Control-> Control Inst.).	–	Sections 1.2, 8.1, 8.2, and 8.4
	Added function for selecting Absolute Time or Relative Time when saving ASCII files.	–	Sections 5.1 and 5.6
	Changed name of CSV conversion function menu (Convert to CSV -> CSV Multiple files conversion), and added function for selecting the save folder.	–	Section 5.6
	Added function for converting WDF files to multiple WVF files.	–	Section 5.7
	Added function for setting the background color to white for printing.	–	Section 6.2
	Added function to the report function for saving to rich text format (rtf).	–	Section 7.3
1.33 or later	Support for SL1000.	–	Section 10.1
1.34 or later	Support for SB5000 series.	SL1000 SB5310/ SB5710	Section 10.1
1.40 or later	Support for Windows Vista	–	Section 10.2
	Added function for manual placement of waveforms on the split screen	–	Section 3.2
	Added character size changing function for T/div display	–	Section 3.4
	Added initialization function for screen display conditions	–	Section 3.6
	Added types of annotations, and improved annotation functions	–	Section 4.7
1.41 or later	Support for DLM2000 series (excluding GP-IB communications and the acquisition data download function.)	DLM2022/DLM2024/ DLM2032/ download DLM2034/DLM2052/ DLM2054	Section 10.1
1.43 or later	Full support for the DLM2000 series	DLM2022/DLM2024/ DLM2032/ DLM2034/ DLM2052/DLM2054	Section 10.1
1.44 or later	Support for the SL1000 mark function	SL1000	Section 10.1
1.51 or later	Support for DL6000/DLM6000 series	DL6000/DLM6000 series	Section 10.1
1.60 or later	Added function for converting WDF/WVF files to multiple FLD files.	–	Section 5.8
	Support for DL850	DL850	Section 10.1
	Support for Windows 7 Support for Floating Point Decimal Files	–	–
1.61 or later	Support for DL850V DL850 Advanced Utility	DL850	Section 10.1 or IM701992-62E
1.62 or later	Support for the merging files to view the waveforms of multiple files at the same time	DL850/DL850V	IM701992-62E
1.63 or later	Support for the DL850V version-up	DL850/DL850V	–
	Support for the Xviewer EYE	–	IM701992-61E
1.64 or later	Support for the DL850/DL850V Real Time Math(/G3)	DL850/DL850V	–

(Continues to the next page)

10.3 Software Versions and the Added Functions

Version	Added Function	Applicable Models	Reference Page/ Section/Chapter
1.70 or later	Added automated measurement functions for history statistics and cycle statistics to the automated measurement of waveform parameters	–	Sections 4.4 and 4.5
	Added history statistics and cycle statistics to the annotation types	–	Section 4.7
	Added a feature for turning waveform interpolation on and off	–	Section 3.3
	Support for Math operations over a specified range	–	Section 4.6
	Added a feature for changing the waveform thickness and grid line thickness that are displayed on the screen	–	Section 3.4
1.72 or later	Support for the 16-CH temperature/voltage input module for DL850/DL850V (720221) and the CAN & LIN Bus monitor module for DL850V (720241)	DL850/DL850V	–
1.73 or later	Support for the DLM4000 series	DLM4000	Section 10.1
	Added a feature that measures cycle statistics over the entire range (mode in which automatic measurement is not performed).		Section 4.6
1.74 or later	Support for the DLM4000 series logic 16 bit input.	DLM4000	Section 10.1
	Added file division for each history waveform.		Section 5.6
1.75 or later	Support for the DL850E/DL850EV	DL850E/DL850EV	Section 10.1
1.76 or later	Support for Windows 7	–	–
	End of support for Windows Vista		
1.78 or later	Support for the frequency module (701281)	DL850 series, SL1000	
	Support for displaying waveforms with different sample rates on the same screen.	–	–
	Support for setting the distal line, mesial line, proximal line, and high and low values for each channel.	–	Section 3.2
	Support for Windows 8.1	–	–
	Support for transferring (uploading) files from a PC to the measuring instrument through Ethernet connection	DL850 series and DLM4000	Section 8.3
1.79 or later	Discontinuation of the support for Windows XP	–	–
	Support for the 100MS/s module (720211)	DL850 series and SL1000	–
	Support for the SENT module (720243), and 4CH module (720254)	DL850 series	–
	Addition of the waveform information display function	–	Section 2.11
	Addition of the label edit function	–	Section 3.2
	Addition of the YKMUSB and VISA selection function	–	Section 8.1
1.80 or later	Support for Windows 10	–	–
	Support for loading and saving MATLAB files	DL850 series	Section 5.1
	Added a feature that measures waveform parameters and history statistics over the entire range (mode in which automatic measurement is not performed).	–	Section 4.3 and 4.4
	Support for the compression rate of 2 for Decim compression	–	Chapter 5
	Alignment of the numbers and displayed order of history waveforms and dual capture waveforms with the measuring instrument	–	Section 2.4
1.82 or later	Support for the DL350	DL350	Section 10.1
	Support for the 10MS/s module (720250), frequency module (720281), Hi-voltage module (720268), and temperature module (720266)		–

(Continues to the next page)

10.3 Software Versions and the Added Functions

Version	Added Function	Applicable Models	Reference Page/ Section/Chapter
1.83 or later	Setting for specifying the order when multiple waveform data files are converted into CSV files	–	Section 5.6
	Setting for changing the size of the trace name display area	–	Section 2.2
	Support for 32 divisions in split view	–	Section 3.3
	Waveform expansion in split view	–	Section 3.3
	Support for RMS computation	–	Section 4.6
	Support for cycle statistics time display	–	Section 4.5
	Language setting	–	Section 1.3
	Saving in WDF file format	–	Section 5.1
1.84 or later	Support for the DLM3000 series	DL850 series and DL350	–
1.84 or later	Support for the DLM3000 series	DLM3000 series	Section 10.1
1.90 or later	Support for the DLM5000 series	DLM5000 series	Section 10.1

- 1 Waveform data (wdf file) can be loaded.
- 2 Supported on version 1.30 or later on the DL1600 Series and version 6.01 or later on the DL750 Series.
- 3 DL750 Series, DL9000 Series, DL7400 Series, DL1700 Series, DL1700E Series, DL1600 Series, and WE7000 are added to the waveform display window
- 4 With the DL750 series, even if you load files that were saved with P-P Com ON in the Save As dialog box, the Upper/Lower, colors, and number of screen divisions are not restored.
- 5 Only remote control possible
- 6 DL1700E series: Version 2.11 or later, DL7400 series: version 2.11 or later
- 7 With the DL1600 series, even if you load files that were saved with Invert ON in the channel settings, the Invert information is not restored.
- 8 DL9000 series: Version 1.80 or later

Index

A

About Xviewer	9-2
Adding an Element	7-6
Address	8-3
Aligning Element	7-6
ASCII format	5-2, 5-6

B

Basic Information	7-3
binary format	5-1, 5-5

C

Changing the Element Property	7-6
Clipboard	4-44
Closing Xviewer	1-1
Color	3-11
comment	2-2
Common Property	7-3
CommSetting	8-1
Communication Setting	8-1
Computational Expression	4-18, 4-20
Connecting to the Instrument	8-1
Controller window	1-2
Control Screen	8-10, 8-15
conversion	5-13, 5-15, 5-17
CSV	5-13
CSV format	5-6
Cursor	4-2
Cursor Data Order	3-7
cycle statistic results, saving	5-11
Cycle Statistics	4-14

D

Deleting an Element	7-6
Deleting a Report File	7-9
Display Setting	3-10, 5-12
Display Size	3-2, 3-8, 3-9
Download	8-7
Dual Capture	2-16

E

Editing Report	7-4
Element Property	7-3
Example of Using the Control Screen	8-12, 8-20

F

FFT	4-19
File List	8-5
Filter	4-19
FLD	5-17
FLD format	5-7
floating point decimal file	5-4

G

Graticule	3-10
Grouping Channels	2-17, 3-2

H

History statistic results, saving	5-11
History Statistics	4-11
History View	2-9
History waveform display window	1-3
History Window	2-9
Horizontal Axis	3-10
Horizontal Cursor	4-2
H&V Cursor	4-4

I

Image Element	7-2
Image file	5-10
Initialize Viewer	3-16
Installing	xii
Int1TY:	4-8
Int1XY	4-8
Int2TY	4-8
Int2XY	4-8

L

Label Edit	3-4
Layout View	7-2
License Number	9-5
Loading a Report File	7-9
Loading Display Settings	3-1
Loading Waveform Data	2-1

M

Main waveform display window	1-3
Main Window	2-6
Mark List	2-18
Math Setting	4-18
MATLAB format	5-5, 5-7
Measurement result display window	1-3
Measurement Result Element:	7-2
Measure Result	3-6, 4-1

N

Notational Format	3-6
-------------------------	-----

O

Operation of the Control Screen	8-10, 8-15
Operator	4-21

P

Precautions	xi
Printer Setup	6-1
Print Format	6-2
Printing Background	6-4
Printing Report	7-10
Print Mode	
DISPLAY	6-3
LONG	6-3
Printout Sample	6-3
Print Preview	6-3
Property by Type	7-3

Index

R

Report Function	7-1
Report List	7-2, 7-6

S

Saving a Report File	7-9
Saving the Display Setting	5-12
Saving Waveform Data	5-1
Scale	3-2
Setting info	5-12
Setting Up a Printer	6-1
Setting Up the Print Format	6-2
Show or Hide	3-2
Software Versions and the Added Functions	10-4
Split	2-15
Split Setting	3-9
Starting Xviewer	1-1
Switching between Groups	2-17
System Environment	10-3

T

Text Element	7-2
Thumbnails	8-6
toolbar	1-2
Tooltip	2-6
Transferring Waveform	5-8
Transfer to Excel	5-8

U

Uninstalling	xiv
Upload	8-7
User Name	8-3
Using the Mouse	8-12

V

Version	9-2
Viewer window	1-2
voice memo	2-2

W

Waveform Color	3-2
Waveform in the Computation View	4-18
waveform property	2-19
Waveform Vertical Zoom&Move	2-13
Wave Parameter	4-5
WDF	5-17
Web Page	9-4
Window Image	7-3
Window Image Element	7-2
WVF	5-17
WVF format	5-5

X

X-Axis	2-11
XLS format	5-3, 5-6
Xreport Window	7-2
X-Y Cursor	4-3
X-Y waveform display window	1-3
X-Y Window	2-11

Z

Zoom	2-7
Zoom Factor	2-7
Zoom Rate	2-8
Zoom waveform display window	1-3