



WAVE FACTORY

MULTIFUNCTION GENERATOR

**WF1967/WF1968**

---

Instruction Manual (Operations)

**NF Corporation**



DA00048287-003

MULTIFUNCTION GENERATOR

**WF1967/WF1968**  
Instruction Manual (Operations)





## Preface

Thank you very much for purchasing our "Multifunction Generator WF1967/WF1968".

To use the instrument in a safe and correct manner, please first read the next section titled "Safety Precautions".

- **Caution symbols used in this manual**

The following caution symbols are used in this manual. Be sure to observe these caution symbols and their contents to ensure the safety of the user and avoid damage to the equipment.

---

**⚠ WARNING**

This symbol indicates information for the avoidance of a hazard that may endanger human life or cause injury during handling of the equipment.

---

---

**⚠ CAUTION**

This symbol indicates information for the avoidance of personal injury or equipment damage during handling of the equipment.

---

- This manual has the following chapter organization.

The instructions for remote control (GPIB, USB, LAN(Optional)) are provided in a separate manual included in the attached CD-ROM.

If using this equipment for the first time, start with "1. Overview."

### Operations

1. Overview

This chapter describes the overview and brief operating principles of this product.

2. Preparations Before Use

This chapter describes important preparations before installation and operation.

3. Panels and I/O Terminals

This chapter describes the functions and operations of the switches and I/O terminals on the panels.

4. Basic Operation

This chapter describes basic operations.

5. Saving and Recalling Settings

This chapter describes how to save and recall the settings.

6. Parameter-Variable Waveforms

This chapter describes the meaning of each parameter and examples of Parameter-Variable waveforms.

## 7. Creating Arbitrary Waveforms

This chapter describes how to input and edit arbitrary waveforms from the panel control.

## 8. Convenient Use of 2-channel Equipment (WF1968 Only)

This chapter describes how to coordinate the settings of two channels.

## 9. Synchronizing Multiple Units

This chapter describes how to configure a multi-phase oscillator by connecting multiple units of this product.

## 10. Using External Frequency Reference

This chapter describes how to use external frequency reference.

## 11. Using Sequence Oscillation

This chapter describes how to set and operate sequence oscillation.

## 12. Using User-defined Units

This chapter describes the units which users can define by themselves.

## 13. Other Utility Settings

This chapter describes how to set display and operational details.

## 14. Troubleshooting

This chapter describes the error messages and handling when problems occur.

## 15. Maintenance

This chapter describes how to perform the operation inspection and performance test.

## 16. List of Initial Settings

This chapter describes the initial settings.

## 17. Specifications

This chapter describes the product's specifications (functions and performance).

## ————— Safety Precautions —————

To ensure safe use, be sure to observe the following warnings and cautions.

NF Corporation shall not be held liable for damages that arise from a failure to observe these warnings and cautions.

This product is a Class I instrument (with protective conductor terminal) that conforms to the JIS and IEC insulation standards.

- **Be sure to follow the contents of the instruction manual.**

This instruction manual contains instructions for safe operation and use of this product.

Please read this manual first before using the product.

All of the warning items contained in this instruction manual are intended for preventing risks that may lead to serious accidents. Be sure to observe these warnings.

- **Be sure to ground the product.**

This product uses a line filter, which may cause electric shock if the product is not grounded.

This product is grounded automatically by connecting a three-pin power supply plug to a power supply outlet with a protective earth contact.

- **Check the power supply voltage.**

This product operates on the power supply voltage indicated in section “2.3 Grounding and Power Supply Connection” in this instruction manual.

Prior to connecting the power supply, check that the outlet voltage matches the rated power voltage of the product.

- **If you suspect a problem**

If this product emits smoke, a strange odor, or an unusual sound, immediately pull the power cable and stop using it.

If such an abnormality occurs, do not let anyone use this product until it has been repaired, and immediately report the problem to NF Corporation or one of our representatives.

- 
- Do not use this product when gas is present.  
Operation of the instrument in a gaseous environment could cause an explosion.
  - Do not remove the cover.  
This product has high-voltage portions inside. Do not remove its cover.  
  
Inspections of the product's interior should only be performed by service technicians authorized by NF Corporation. Do not touch the inside of the instrument.
  - Do not modify the product.  
Do not modify the instrument under any circumstances. Modification of the instrument could cause unexpected accidents or failures. NF Corporation has the right to refuse to repair any instruments modified by unauthorized persons.
  - Safety-related symbols  
The general definitions of the safety-related symbols used on this product and in the instruction manual are provided below.



#### Instruction Manual Reference Symbol

This notifies the user of potential hazards and indicates that he/she must refer to the instruction manual.



#### Electric Shock Danger Symbol

This symbol indicates locations that present a risk of electric shock under specific conditions.



#### Warning Symbol

This symbol indicates information for the avoidance of hazards such as electric shock that may endanger human life or cause injury during handling of the equipment.



#### Caution Symbol

This symbol indicates information for the avoidance of damage to the equipment during handling.

- Other symbols



This mark indicates that the outer conductor of the connector is connected to the enclosure.



This mark indicates that the outer conductor of the connector is insulated from the enclosure.

However, for safety reasons it indicates that the potential difference from the grounding

---

potential is restricted to 42Vpk or less (since this product is grounded when being used, the potential of the enclosure equals the grounding potential).

- Requesting waste disposal

To protect the environment, ensure that this device is disposed of by an appropriate industrial waste processor. A battery is not used in this product.



---

# Table of Contents

---

	Page
—— Preface —— .....	i
1. Overview .....	1-1
1.1 Features .....	1-2
1.2 Operating Principles .....	1-4
2. Preparations Before Use .....	2-1
2.1 Checking Before Use .....	2-2
2.2 Installation .....	2-3
2.3 Grounding and Power Supply Connection .....	2-5
2.4 Firmware Update .....	2-6
2.5 Calibration .....	2-6
3. Panels and I/O Terminals.....	3-1
3.1 Panel Component Names and Functions.....	3-2
3.1.1 Front Panel of WF1967.....	3-2
3.1.2 Rear Panel of WF1967 .....	3-3
3.1.3 Front Panel of WF1968.....	3-4
3.1.4 Rear Panel of WF1968 .....	3-5
3.2 I/O Terminals .....	3-6
3.2.1 Waveform Output (FCTN OUT).....	3-7
3.2.2 Synchronization/Sub-output (SYNC/SUB OUT) .....	3-8
3.2.3 External Modulation/Addition Input (MOD/ADD IN).....	3-10
3.2.4 External Trigger Input (TRIG IN) .....	3-11
3.2.5 External 10MHz Frequency Reference Input (10MHz REF IN) .....	3-12
3.2.6 Frequency Reference Output (REF OUT).....	3-13
3.2.7 Multi-I/O (MULTI I/O) .....	3-15
3.3 Cautions on Floating Ground Connection .....	3-18
4. Basic Operations .....	4-1
4.1 Power On/Off and Restoration of Settings .....	4-2
4.1.1 How to Turn Power On/Off.....	4-2
4.1.2 Restoration of Settings at Power-on .....	4-3
4.2 Screen Configuration and Operation.....	4-6
4.2.1 Screen Configuration .....	4-6
4.2.2 Switching Display Format with Tabs (To Display Waveform Graph) .....	4-8
4.2.3 To use USB flash memory(Switching with tab).....	4-10
4.2.4 Top Menu.....	4-11
4.3 Basic Settings and Operations.....	4-12
4.3.1 To Change Frequency, Amplitude, and Other Values .....	4-12

4.3.2	To Change Waveforms .....	4-15
4.3.3	Shortcut Keys for Changing Basic Parameters .....	4-16
4.3.4	Functions of ENTER/CANCEL/UNDO Key .....	4-17
4.3.5	Change Display Unit .....	4-18
4.3.6	CH1/CH2 Switching Key and Active Channel (WF1968 Only) .....	4-20
4.3.7	Operations Available on Utility .....	4-21
4.3.8	To Restore Initial Settings .....	4-23
4.3.9	Output On/Off .....	4-23
4.4	Setting for Main Items .....	4-26
4.4.1	Text Display Screen in Continuous Oscillation Mode .....	4-26
4.4.2	To Set Oscillation Mode .....	4-27
4.4.3	To Set Waveforms .....	4-28
4.4.4	To Set Frequency .....	4-28
4.4.5	To Set Period .....	4-29
4.4.6	To Set Phase .....	4-30
4.4.7	To Set the Synclator Function .....	4-32
4.4.8	To Set Amplitude .....	4-33
4.4.9	To Set DC Offset .....	4-35
4.4.10	To Set Output Level with High/Low Level .....	4-36
4.4.11	To Set Waveform Polarity and Amplitude Range .....	4-38
4.4.12	How to Use Auto Range/Range Hold for Output Voltage .....	4-40
4.4.13	To Set Load Impedance .....	4-41
4.4.14	To Add External Signal .....	4-42
4.4.15	To Set Duty of Square Wave .....	4-44
4.4.16	To Set Pulse Width and Rising/Falling Time of Pulse Wave .....	4-46
4.4.17	To Set Ramp Wave Symmetry .....	4-49
4.4.18	To Set the Equivalent Noise Bandwidth .....	4-49
4.4.19	To Select Sub Output .....	4-49
4.4.20	To Use Sub Waveforms .....	4-50
4.5	Using Variable Parameter Waveforms .....	4-52
4.6	Using Arbitrary Waveforms .....	4-53
4.7	Setting and Operation of Modulation .....	4-54
4.7.1	Modulation Types .....	4-54
4.7.2	Screen for Setting and Operation of Modulation .....	4-55
4.7.3	Common Settings and Operation of Modulation .....	4-58
4.7.4	Setting FM .....	4-61
4.7.5	Setting FSK .....	4-62
4.7.6	Setting PM .....	4-63
4.7.7	Setting PSK .....	4-64
4.7.8	Setting AM .....	4-66
4.7.9	Setting AM (DSB-SC) .....	4-68
4.7.10	Setting DC Offset Modulation .....	4-69



4.7.11	Setting PWM.....	4-70
4.8	Setting and Operation of Sweep .....	4-71
4.8.1	Sweep type (Sweep type) .....	4-71
4.8.2	Screen for Setting and Operation of Sweep .....	4-71
4.8.3	Common Setting and Operation of Sweep .....	4-74
4.8.4	Setting Frequency Sweep .....	4-82
4.8.5	Setting Phase Sweep .....	4-83
4.8.6	Setting Amplitude Sweep .....	4-84
4.8.7	Setting DC Offset Sweep .....	4-85
4.8.8	Setting Duty Sweep .....	4-86
4.9	Setting and Operation of Burst.....	4-88
4.9.1	Burst Oscillation Types(Burst mode) .....	4-88
4.9.2	Screen for Setting and Operation of Bursts.....	4-88
4.9.3	Auto burst .....	4-90
4.9.4	Trigger burst .....	4-93
4.9.5	Gate Oscillation .....	4-98
4.9.6	Triggered Gate Oscillation .....	4-102
5.	Saving and Recalling Settings .....	5-1
5.1	Procedure to Save Settings .....	5-2
5.1.1	To save to build on memory .....	5-2
5.1.2	To save to USB flash memory .....	5-3
5.2	Procedure to Recall Settings .....	5-4
5.2.1	To recall from build on memory .....	5-4
5.2.2	To recall from USB flash memory .....	5-5
5.3	Restoring Saved Contents to Initial Settings .....	5-6
5.4	Changing Setting Memory Name .....	5-6
5.5	USB Flash Memory Operations .....	5-7
5.5.1	File List .....	5-7
5.5.2	To Change the Current Folder .....	5-7
5.5.3	Creating Folders .....	5-7
5.5.4	Deleting Folders .....	5-7
5.5.5	Time stamp of files.....	5-7
6.	Variable Parameter Waveforms .....	6-1
6.1	Categories .....	6-2
6.2	Meaning of Each Parameter and Waveform Examples .....	6-3
6.2.1	Outline .....	6-3
6.2.2	Steady Sine Group .....	6-4
6.2.3	Transient Sine Group.....	6-10
6.2.4	Pulse Group.....	6-14
6.2.5	Transient Response Group .....	6-20
6.2.6	Surge Group .....	6-24
6.2.7	Other Waveforms Group (Others Group) .....	6-26

7.	Creating Arbitrary Waveforms .....	7-1
7.1	Basics .....	7-2
7.2	Display Procedure and Overview of Screen for Creating/Editing Arbitrary Waveforms .....	7-3
7.3	Creating New Arbitrary Waveform .....	7-5
7.4	Simple Arbitrary Waveform Creating Example .....	7-6
7.5	Outputting Created Arbitrary Waveform .....	7-7
7.6	Saving Created Arbitrary Waveform .....	7-7
7.6.1	Saving to Internal Memory .....	7-8
7.6.2	Saves to USB Flash Memory .....	7-8
7.7	To Use the Saved Arbitrary Waveform .....	7-9
7.7.1	To Retrieve From Internal Memory .....	7-10
7.7.2	To Retrieve From USB Flash Memory .....	7-11
7.8	To Delete the Saved Arbitrary Waveform .....	7-12
7.8.1	To Delete From Internal Memory .....	7-12
7.8.2	To Delete From USB Flash Memory .....	7-12
7.9	Identifying Memory Space Required for Saving Arbitrary Waveforms .....	7-13
8.	Convenient Use of 2-channel Equipment .....	8-1
8.1	Outline .....	8-2
8.2	Copying Setting between Channels .....	8-3
8.3	Unifying Settings of 2 Channels .....	8-5
8.4	Phase Synchronization between Channels .....	8-6
8.5	Maintaining to Same Frequency (2-Channel Coordination, 2-Phase) .....	8-7
8.6	Keeping Frequency Difference Constant (2-Channel Coordination, 2-Tone) .....	8-9
8.7	Keeping Frequency Ratio Constant (2-Channel Coordination, Ratio) .....	8-11
8.8	Obtaining Differential Output (2-Channel Coordination, Differential) .....	8-13
8.9	Obtaining Double Output Voltage(2-Channel Coordination, Differential 2) .....	8-14
9.	Synchronizing Multiple Units .....	9-1
9.1	Connection Procedure .....	9-2
9.2	Performing Synchronization .....	9-4
10.	Using External Frequency Reference .....	10-1
10.1	Purpose of Using External Frequency Reference .....	10-2
10.2	Connection and Usage Procedure of External Frequency Reference .....	10-2
11.	Using the Sequence Oscillation .....	11-1
11.1	Sequence Oscillation Example .....	11-2
11.2	Basics .....	11-4
11.3	In-Step Processing Flow .....	11-12
11.4	Setting and Operation Procedure .....	11-13
11.5	Saving Created Sequence .....	11-17
11.5.1	Saving to the Built-In Memory of Main Body .....	11-17
11.5.2	Saving to the USB Flash Memory .....	11-18
11.6	Using the Saved Sequence .....	11-19
11.6.1	Recalling from the Built-In Memory .....	11-19

11.6.2	Recalling from the USB Flash Memory .....	11-19
11.7	Deleting the Saved Sequence.....	11-20
11.7.1	Deleting from the Built-In Memory .....	11-20
11.7.2	Deleting from the USB Flash Memory.....	11-20
11.8	Outline of Screen .....	11-21
11.9	Individual Description of Step Control Parameters.....	11-23
11.10	Tips for Sequence Creation .....	11-24
12.	Using User-defined Units.....	12-1
12.1	About User-defined Unit .....	12-2
12.2	Display and Setting in User-defined Unit .....	12-2
12.3	Defining User-defined Units .....	12-3
13.	Other Utility Settings.....	13-1
13.1	Selecting Remote Interface [Remote] .....	13-2
13.2	Display Setting [Display] .....	13-2
13.3	Modify Knob and Modify Direction Setting [Modify Direction] .....	13-2
13.4	Operation Sound Setting [Sound] .....	13-3
13.5	Self-Diagnosis [Self Check] .....	13-3
13.6	Product Information Display [Information] .....	13-3
14.	Troubleshooting.....	14-1
14.1	Error Messages at Power-on .....	14-2
14.2	Error Messages during Operation .....	14-3
14.3	Conflict Messages for Modulation .....	14-7
14.4	Conflict Message for Sweep .....	14-8
14.5	Conflict Message for Burst.....	14-9
14.6	Sequence Compiler Message .....	14-10
14.7	Suspected Failure.....	14-11
15.	Maintenance.....	15-1
15.1	Outline .....	15-2
15.2	Operation Inspection.....	15-4
15.3	Performance Test.....	15-5
15.3.1	Frequency Accuracy Test.....	15-5
15.3.2	Sine Wave Amplitude Accuracy Test .....	15-6
15.3.3	DC Offset Accuracy Test .....	15-6
15.3.4	Sine Wave Amplitude/Frequency Characteristics Test .....	15-7
15.3.5	Sine Wave Total Harmonic Distortion Test .....	15-9
15.3.6	Sine Wave Harmonic Spurious Test .....	15-9
15.3.7	Sine Wave Non-harmonic Spurious Test .....	15-10
15.3.8	Square Wave Duty Accuracy Test .....	15-10
15.3.9	Square Wave Leading/Trailing Time Test.....	15-11
15.3.10	Time Difference Between Channels for 2-Phase (WF1968 Only).....	15-11
16.	List of Initial Settings .....	16-1
17.	Specifications .....	17-1

17.1	Oscillation Mode .....	17-2
17.2	Waveform .....	17-2
17.2.1	Standard Waveform .....	17-2
17.2.2	Arbitrary Waveform .....	17-2
17.3	Frequency, Phase .....	17-3
17.3.1	Frequency.....	17-3
17.3.2	Phase .....	17-4
17.4	Output Characteristics .....	17-4
17.4.1	Amplitude .....	17-4
17.4.2	DC Offset.....	17-5
17.4.3	Load Impedance Setting.....	17-5
17.4.4	Waveform Output.....	17-6
17.4.5	Synchronization/Sub-Output .....	17-6
17.5	Signal Characteristics .....	17-7
17.5.1	Sine Wave .....	17-7
17.5.2	Square Wave .....	17-8
17.5.3	Pulse Wave .....	17-9
17.5.4	Ramp Wave .....	17-9
17.5.5	Noise .....	17-9
17.5.6	Parameter-Variable Waveform .....	17-10
17.6	Modulated Oscillation Mode.....	17-11
17.6.1	General.....	17-11
17.6.2	FM.....	17-12
17.6.3	FSK .....	17-13
17.6.4	PM.....	17-13
17.6.5	PSK .....	17-13
17.6.6	AM.....	17-13
17.6.7	DC Offset Modulation .....	17-14
17.6.8	PWM.....	17-14
17.7	Sweep Oscillation Mode .....	17-14
17.7.1	General.....	17-14
17.7.2	Frequency Sweep.....	17-17
17.7.3	Phase Sweep .....	17-17
17.7.4	Amplitude Sweep.....	17-17
17.7.5	DC Offset Sweep .....	17-17
17.7.6	Duty Sweep .....	17-18
17.8	Burst Oscillation Mode .....	17-18
17.9	Synclator Function .....	17-19
17.10	Trigger .....	17-20
17.11	Sequences.....	17-21
17.12	Other I/Os .....	17-22
17.13	2-Channel Coordination (WF1968 only) .....	17-23

17.14 Synchronization of Multiple Units .....	17-25
17.15 User-defined Unit.....	17-26
17.16 Other Functions .....	17-26
17.17 Options .....	17-27
17.18 General Characteristics .....	17-27

---

# Figures and Tables

---

	Page
Figure 1-1 WF1967 Block Diagram .....	1-4
Figure 1-2 WF1968 Block Diagram .....	1-5
Figure 3-1 Front Panel of WF1967 .....	3-2
Figure 3-2 Rear Panel of WF1967 .....	3-3
Figure 3-3 Front Panel of WF1968 .....	3-4
Figure 3-4 Rear Panel of WF1968 .....	3-5
Figure 3-5 Multi-I/O connector pin configuration diagram.....	3-16
Figure 3-6 Cautions on floating ground connection for WF1967 .....	3-19
Figure 3-7 Cautions on floating ground connection for WF1968 .....	3-19
Table 3-1 Signals Selectable for Synchronization/Sub-output .....	3-8
Table 3-2 Multi-I/O connector pin assign .....	3-16

# 1. Overview

- 1.1 Features ..... 1-2
- 1.2 Operating Principles ..... 1-4

## 1.1 Features

The WAVE FACTORY "WF1967 Multifunction Generator" and "WF1968 Multifunction Generator" are multifunctional oscillators based on DDS (Direct Digital Synthesizer).

The WF1967 features one channel and the WF1968 features two channels.

- Maximum Frequency: 200MHz (Sine wave), 70MHz (Square wave, Pulse)
- Frequency Accuracy:  $\pm(3\text{ppm}+6\text{pHz})$ , Maximum high resolution of 0.01 $\mu\text{Hz}$  Supports a 10MHz External Frequency Reference
- Maximum Output Voltage: 20Vp-p/open (10Vp-p/50 $\Omega$ , 110MHz or less), 4Vp-p/open (2Vp-p/50 $\Omega$ , 110MHz to 200MHz), Minimum Output Voltage: 0V (Can reach 0 using Amplitude control)
- Standard Waveforms with Multivariable Parameters: Sine wave, Square wave (variable duty), Pulse (variable pulse width/duty, rising time, falling time), Ramp wave (variable symmetry), CF control Sine wave (variable crest factor), Staircase Sine wave (variable step number), Gaussian pulse (variable  $\sigma$ ), Sin(x)/x (variable number of zero crossings), exponential rise/fall (variable time constant), Damped oscillation (variable oscillation frequency, damping time constant), Pulse surge (variable rise, duration time), Trapezoid wave (variable rise, fall, upper width), etc.
- Synclator function to output an external input signal at the same frequency.
- Maintains the flatness of frequency characteristics (Sine wave amplitude) during frequency sweeps and frequency modulation.
- Output waveform resolution: Approximately 16 bit (retains high resolution across a wide range of output voltages)
- High capacity arbitrary waveform memory: Maximum 1Mi words, storage capacity of 128 waveforms/4Mi words (Mi expresses  $2^{20}=1048576$  as per IEC 60027-2/ IEEE 1541-2002)
- Continuous phase and uninterrupted waveform during frequency change and frequency sweep
- Square wave and Pulse with high resolution, variable duty of 0.0001%
- Pulse with variable rising time, falling time
- Various oscillation modes
  - Continuous oscillation mode
  - Modulation: FM, FSK, PM, PSK, AM, DC Offset Modulation, PWM
  - Sweep: Frequency, phase, amplitude, DC offset, and duty
  - Burst oscillation : Auto burst, Trigger burst, Gate oscillation, Triggered gate oscillation
  - Synclator function: Any waveform can oscillate at the same frequency as that supplied to the external trigger input terminal.
  - Sequence Oscillation: Waveform/Frequency/Phase/Amplitude/DC Offset and Square wave duty, Constant value /Linear interpolation, Jump/Repeat/Hold/Branch.
- Sequence function for easy test waveform creation and editing  
Flexible waveform creation by combining with standard waveforms with variable parameters  
Supports rapid change and sweep of frequency, phase, amplitude, etc.
- Intuitive user interface with a WQVGA high resolution TFT color LCD



- Two-channel ganged function with 2 phases, constant frequency difference, constant frequency ratio, etc. (only WF1968).
- Each channel uses a floating ground with the enclosure to reduce the effects of ground loops.
- Supports the synchronization of multiple units to configure a multiphase oscillator.
- Built-in USB, GPIB interface
- Storage of settings and arbitrary waveforms in USB flash memory
- Compact and lightweight with approximate height of 13cm, width of 22cm, and weight of 3.0kg
- Supports output of different frequencies and waveforms from sub and main outputs

## 1.2 Operating Principles

### ■ WF1967 Block Diagram

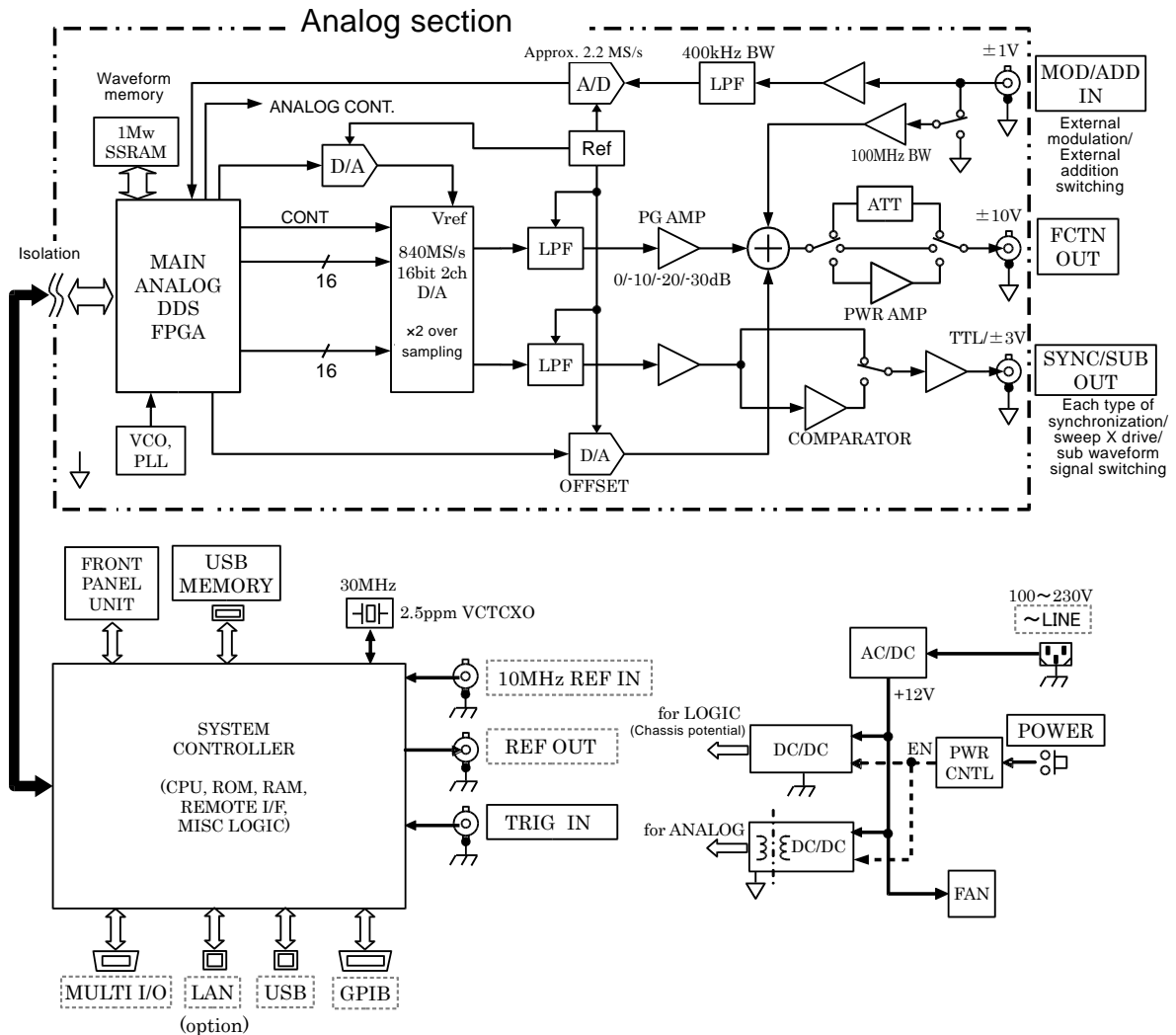

Figure 1-1 WF1967 Block Diagram

### ■ Analog Section

- DDS (Direct Digital Synthesizer) operates on a clock of 840MHz or 420MHz and generates various types of oscillations and waveforms. The DDS also generates of modulation, sweeps and bursts.
- Digital waveform signals generated by DDS are controlled by the specified polarity (normal or inversed) and amplitude range (-FS/0, ±FS, 0/+FS). After the amplitude is digitally adjusted, the waveform is input to the D/A converter.
- Also, the D/A converter, analog amplitude control is performed.  
waveform is converted into analog signal is smoothed by the LPF (low pass filter).
- The amplitude is controlled in 10dB steps by the PG AMP (variable gain amp).
- An external addition signal and DC offset are added to the PG AMP output. If an output voltage of  $\pm 400\text{mV}/\text{open}$  or less, attenuator of 1/5x is applied. If an output voltage greater than  $\pm 2\text{V}/\text{open}$ , 5x amplifier is applied.

- The maximum output voltage of this product is 20Vp-p, 4Vp-p or 800mVp-p depending on whether or not the 1/5x ATT or the 5x amp is used. Correspondingly, the external addition gain changes to 10x, 2x or 0.4x.

■ Diagram: WF1968Block Diagram

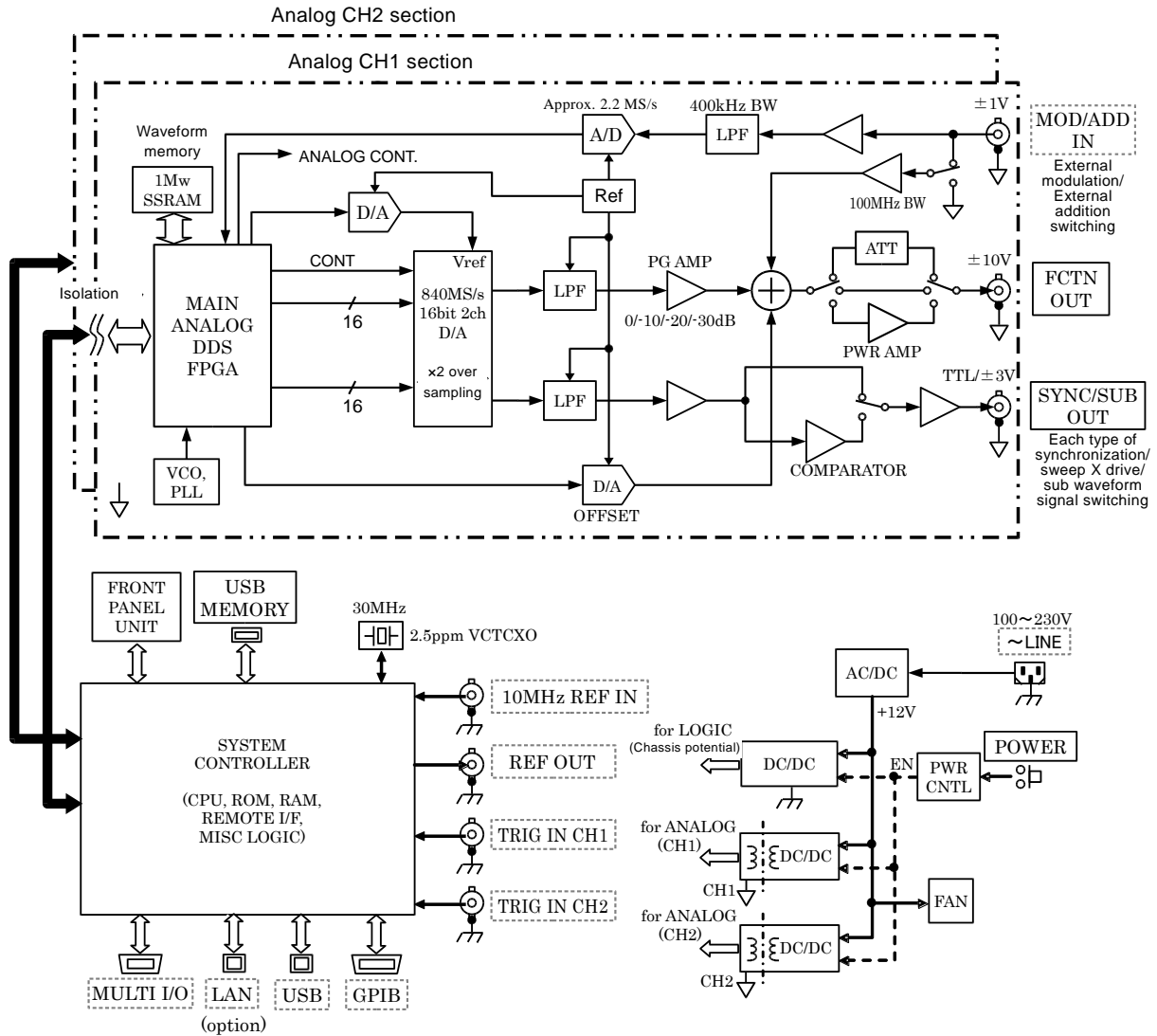

Figure 1-2 WF1968 Block Diagram

- The external modulation signal passes through the LPF, is converted from analog to digital by the A/D and then input into the DDS.
- The Analog section is insulated from the System Controller section which is grounded in the potential of the enclosure.
- The WF1968 has two channels with independent Analog sections that are insulated from the potential of the enclosure.

■ System Controller

- This section controls the display, panel key, remote control (GPIB, USB, LAN(Optional)), trigger input, frequency reference, DDS, amplitude, and DC offset.
- A 30MHz crystal oscillator is used for DDS clock.

- In order to synchronize multiple units by a signal to REF OUT (frequency reference output), it sends a channel synchronization (WF1968 only) signal to the Analog section of each channel.

### ■ Power Supply

- Continuously supplies power from the AC/DC source directly connected to the power input.
- Performs a start-up or shutdown of power supply circuit in response to operation of the power switch.

## 2. Preparations Before Use

2.1	Checking Before Use .....	2-2
2.2	Installation .....	2-3
2.3	Grounding and Power Supply Connection .....	2-5
2.4	Firmware Update .....	2-6
2.5	Calibration .....	2-6

## 2.1 Checking Before Use

### a) Safety check

For your own safety, please be sure to first read the following section of this manual.

- "Safety Precautions" (See page iii.)
- "2.3 Grounding and Power Supply Connection"

### b) Checking the Exterior and Accessories

If the exterior of the cardboard container appears to be damaged (scrapes or dents, etc.), please be sure to check the product for any signs of damage after take out from the container.

Please confirm the contents after take out them from the container.

If there are any signs of damage to the exterior of the product or if any of the accessories are missing, please contact NF Corporation or dealer.

- **Checking the Exterior**

Please check that equipment has any damages on the panel, knobs and connectors.

- **Checking the Configuration and Accessories**

This product is configured as follows: Please confirm that no items are missing are damaged.

Main unit .....	1
Instruction Manual (Operations) .....	1
CD (PDF Instruction Manual, Application software) .....	1
PDF Instruction Manual:	
Operations, Remote control,	
Arbitrary waveform editing software, Sequence editing software,	
Application software:	
Arbitrary waveform editing software, Sequence editing software,	
IVI (Interchangeable Virtual Instruments) Driver	
Power code set (2m with 3-pin plugs) .....	1

### WARNING

This product has high-voltage portions inside. Absolutely never remove its cover.

Do not touch the inside by yourself in any case.

### c) Repackaging

When you re-pack the instrument for transportation, etc., use a box with appropriate strength and size margin and some padding which can support the weight, to protect the instrument sufficiently.

### d) Rack Mounting Kit (optional)

Adapters for mounting the equipment in a 19-inch IEC, EIA standard rack, or JIS standard rack. There are four types of adapter in total, an adapter for one unit and an adapter for two units (for side-by-side mounting) for each product model.

They must be purchased separately.

---

## 2.2 Installation

### a) Installation location

Do not place the instrument with the rear side down. It may damage the connectors and hinder ventilation. Place the equipment on the flat surface such as a desk so that the four rubber feet and stands rest on that surface.

### b) Installation conditions

- **This product uses a forced air cooling system with a fan, and for this purpose it has air intake and outlet ports on the bottom and rear sides. Be sure to install the equipment with its bottom and rear surfaces at least 10 cm away from the wall to allow for air circulation.**
- **Install the instrument in a location where the temperature and humidity meet the following conditions.**

Operational requirements: 0 to 40°C, 5 to 85%RH

Storage requirements: –10to 50°C, 5 to 95%RH

Use the instrument without condensation. For limitations related to absolute humidity, refer to the specifications in this manual.

- **Install the instrument at an altitude of 2000m or less.**
- **Do not install the device in the following locations:**
  - Place exposed to inflammable gas  
This may pose a risk of explosion. Never install, use or operate the instrument in such an environment.
  - Outdoors, exposed to direct sunlight, or located near fire or a heat source  
If the instrument is installed in such environment, it may not meet the performance specifications or instrument failures may be induced.
  - Environment with corrosive gas, moisture or dust, or with high humidity  
The instrument could be corroded or damages could be induced due to such environment.
  - Place near an electromagnetic field source, high-voltage equipment, or power line  
This may cause malfunction.  
Powerful electromagnetic radio frequencies may mix with the output.
  - Location with frequent vibrations  
Operating the instrument in such environment could cause malfunctions and/or failures.

### c) Maintenance of the panel and housing

When the panel/housing surface needs cleaning, wipe it with a soft cloth. To remove persistent contamination, wipe it with a soft cloth soaked with neutral detergent and wrung out.

Never use such volatile solvent as thinner or benzine, or chemically treated towels, to wipe

---

the instrument surface. Otherwise, the surface treatment might be altered and/or its paint might be damaged.

**d) Rack mounting method**

This product can be mounted in a 19-inch IEC, EIA standard rack, or a JIS standard rack using a rack mounting kit (optional). In a rack, you can mount just one unit, or two units side by side.

First, attach the rack mounting kit to the main unit, and then mount the unit in the rack. To use the rack mounting kit, please refer to the manual included with the kit. Following attention should be drawn when you mount the equipment in the rack:

- Be sure to install rails in the rack to support the equipment.
- Do not mount this product in an enclosed rack; otherwise, internal temperatures may rise high enough to induce operational failures.  
Prepare ventilation openings on the rack, or install an air flow system in the rack by using a fan.

For the dimensional drawings for rack mounting, refer to:

Rack mount dimensional drawing (EIA, for 1 unit)	☞ P.17-31
Rack mount dimensional drawing (EIA, for 2 units)	☞ P.17-32
Rack mount dimensional drawing (JIS, for 1 unit)	☞ P.17-33
Rack mount dimensional drawing (JIS, for 2 units)	☞ P.17-34



## 2.3 Grounding and Power Supply Connection

Be sure to ground the product.

---

### **WARNING**

This product uses a line filter, which may cause electric shock if the product is not grounded.

To prevent electric shock accidents, connect the product to ground.

---

This product is automatically grounded when its three-pole power supply plug is connected to a three-pole power outlet with a protective conductor terminal.

#### **a) Power supply conditions**

Voltage range: 100VAC to 230VAC  $\pm$ 10% (250V or lower)

Frequency range: 50Hz/60Hz

Power consumption: WF1967: 65VA or lower, WF1968: 85VA or lower

#### **b) Connection procedure of the power source**

- 1) Confirm that the commercial power source voltage is within the allowable voltage range of this product.
- 2) Connect the power cord into power supply inlet on the rear side of this product.
- 3) Connect the power cord into the three-pole power source outlet.

---

### **CAUTION**

The accessory power supply cable set is designed to be used for this product only. Do not use it for any other product or purposes.

---

**The power code set can be used for disconnecting the product from AC power line in case of emergency.**

---

### **WARNING**

Maintain enough space around the inlet, to be able to remove the connector of a power cord from the inlet. Use a power socket located at convenient place with adequate space around so that the plug can be removed from socket.

---

## 2.4 Firmware Update

How to check the version of the product of the firmware, refer to Section 13.6. ☞ P. 13-3

Specific steps of the latest version and update the firmware, will be provided at the support page of our Web page (<http://www.nfcorp.co.jp/index.html>). On the update contents of your confirmation, please perform the update as necessary.

## 2.5 Calibration

This equipment should undergo performance testing about once a year as a guideline, although this depends on the usage environment and usage frequency. Moreover, when using this equipment to perform important measurements and tests, the execution of a performance test immediately before is recommended.

Performance testing of this equipment should be performed by a person with general knowledge of test instruments and experienced in their operation.

For details of the performance test, please refer to ☞P.15-5

## 3. Panels and I/O Terminals

3.1	Panel Component Names and Functions .....	3-2
3.2	I/O Terminals .....	3-6
3.3	Cautions on Floating Ground Connection .....	3-18

### 3.1 Panel Component Names and Functions

This section describes the names and functions of the components on the front panel and rear panel.

#### 3.1.1 Front Panel of WF1967

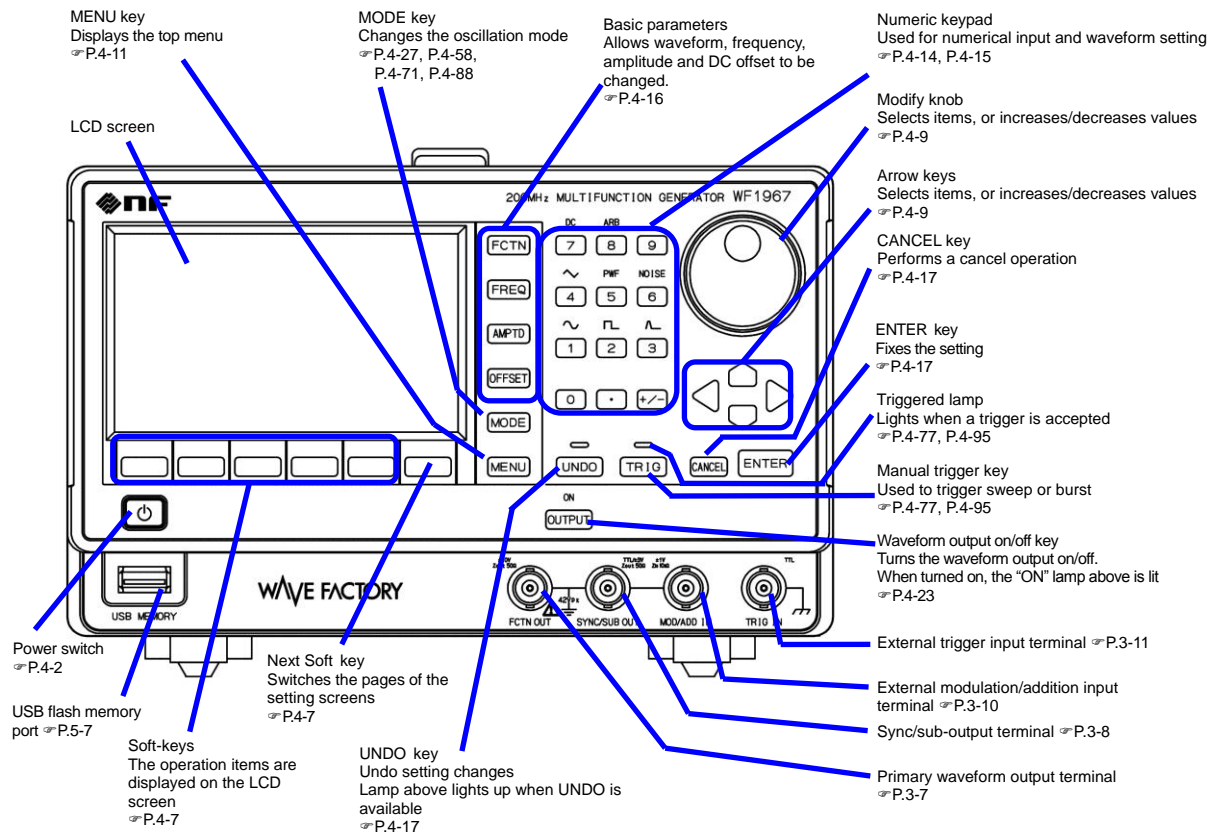

Figure 3-1 Front Panel of WF1967

3.1.2 Rear Panel of WF1967

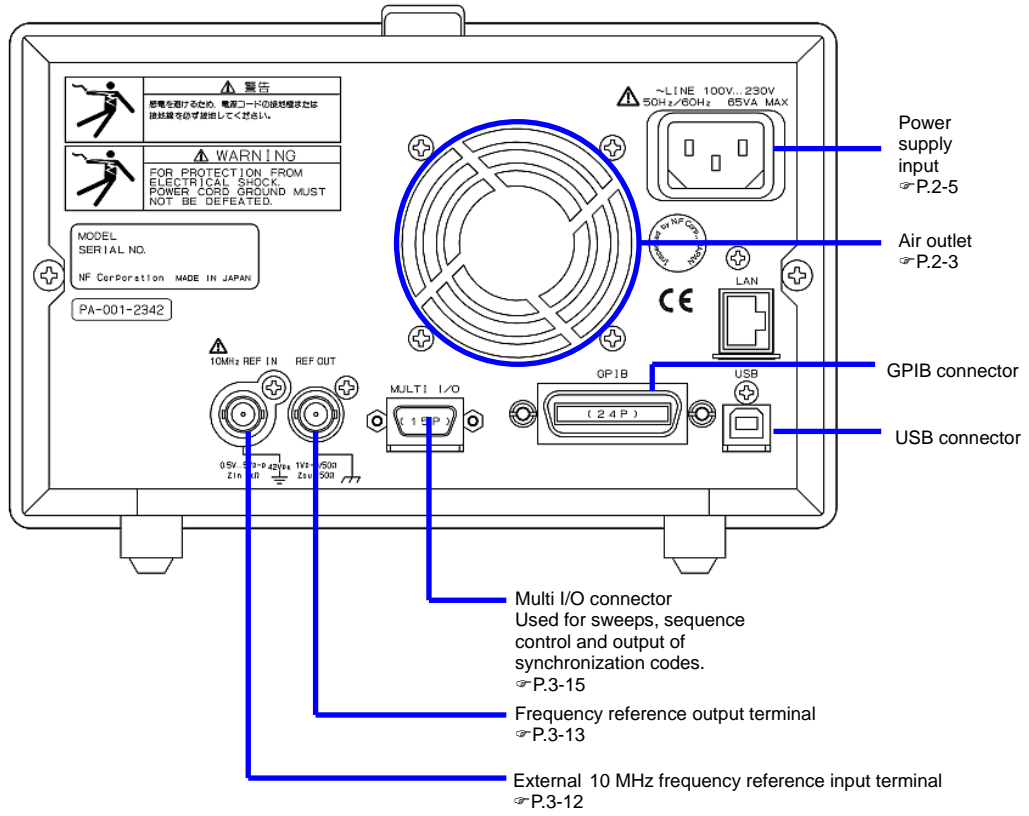

Figure 3-2 Rear Panel of WF1967

3.1.3 Front Panel of WF1968

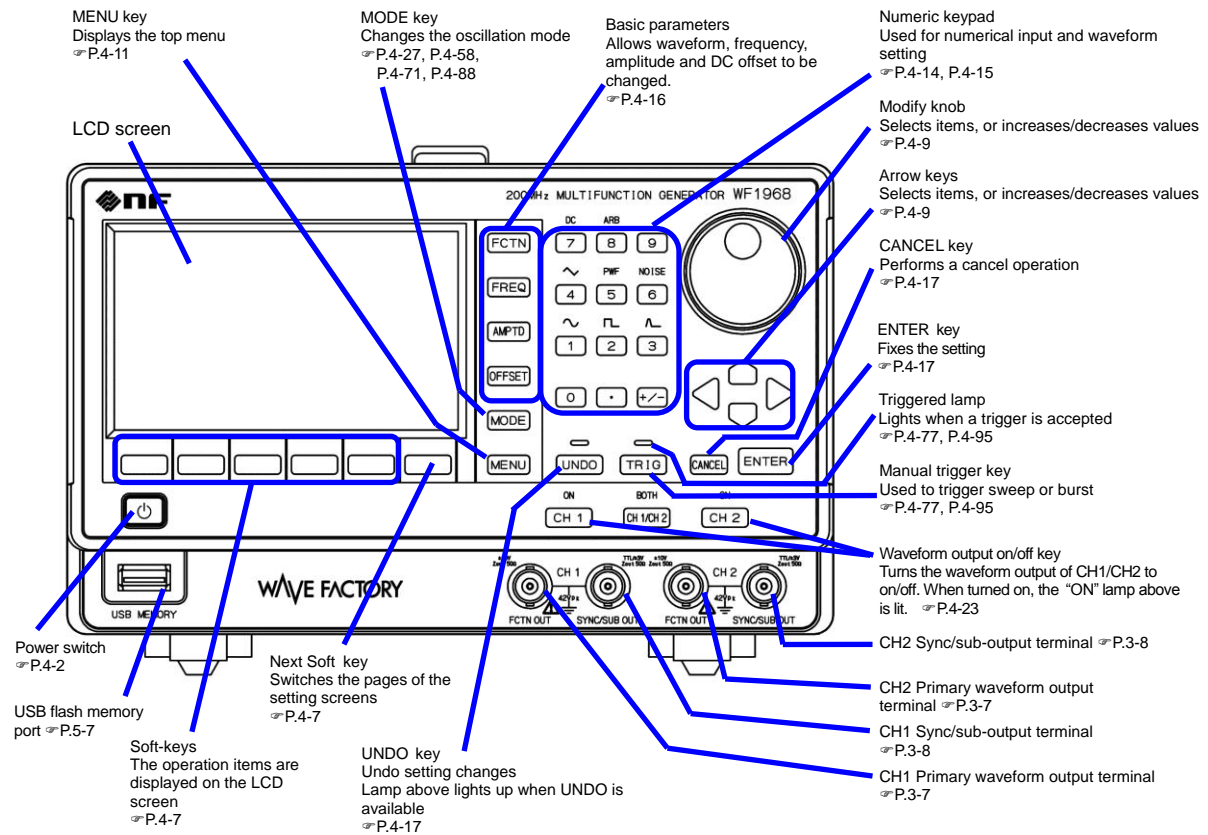

Figure 3-3 Front Panel of WF1968

3.1.4 Rear Panel of WF1968

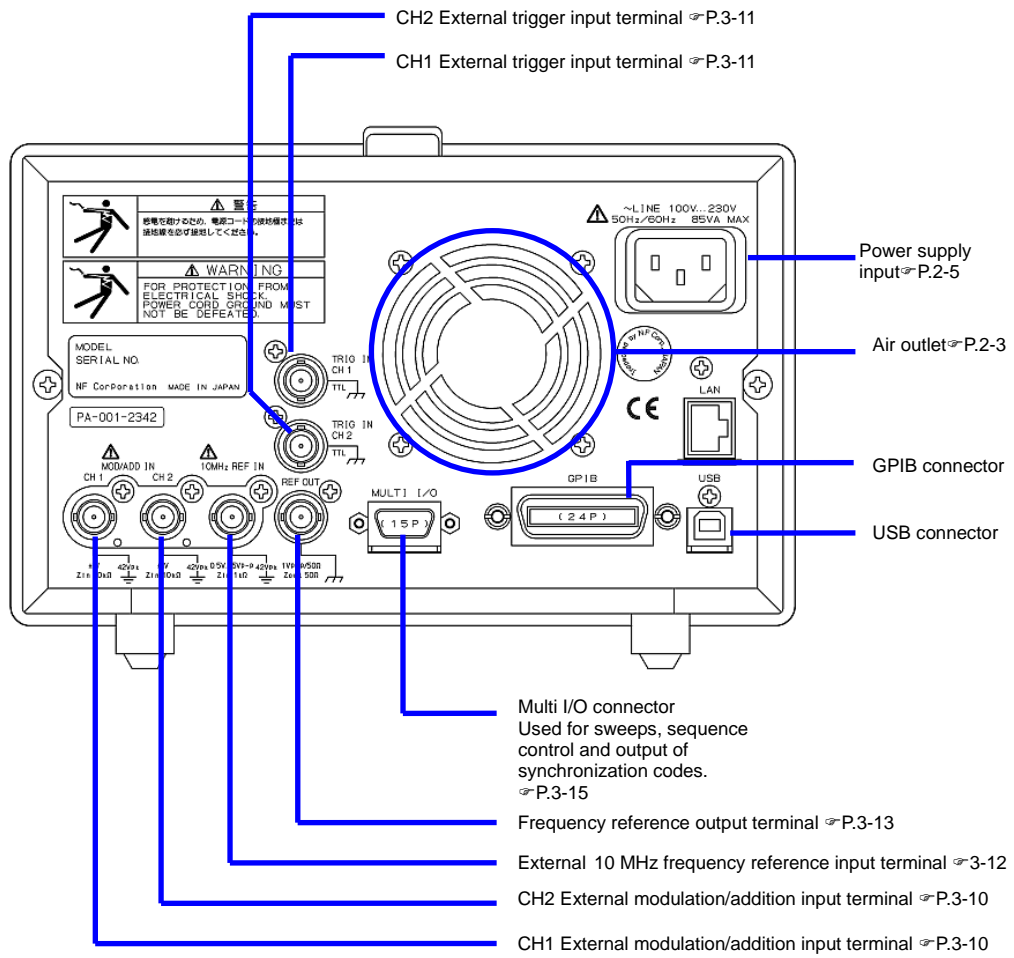

Figure 3-4 Rear Panel of WF1968

---

## 3.2 I/O Terminals

---

### **WARNING**

To prevent electric shocks, do not apply a voltage exceeding 42Vpk (DC + AC peak) between the ground of the BNC connectors insulated from the enclosure and the enclosure.

Also, do not apply a voltage exceeding 42Vpk (DC + AC peak) between the grounds of the BNC connector groups insulated from the enclosure. "BNC connector groups" used here, indicates multiple BNC connectors that are connected to a common ground.

If such a high voltage is applied, the internal voltage limiting elements will try to reduce the voltage, but a too high voltage may cause the product to be burned.

☞ P.3-18

---

---

### **CAUTION**

Do not apply a voltage from external to the output terminals.  
This may damage the product.

---

---

### **CAUTION**

Do not apply a voltage exceeding the maximum allowable voltage to the input terminal. This may damage the product.

---

---

### **CAUTION**

If a difference in potential exists between the ground of a BNC connector insulated from the enclosure and the enclosure, do not short-circuit the hot side of that BNC connector and the enclosure.  
This may damage the product.

---

---

### **CAUTION**

If a difference in potential exists between the grounds of BNC connectors, do not short circuit these BNC connector grounds. This may damage the product.

---



### 3.2.1 Waveform Output (FCTN OUT)

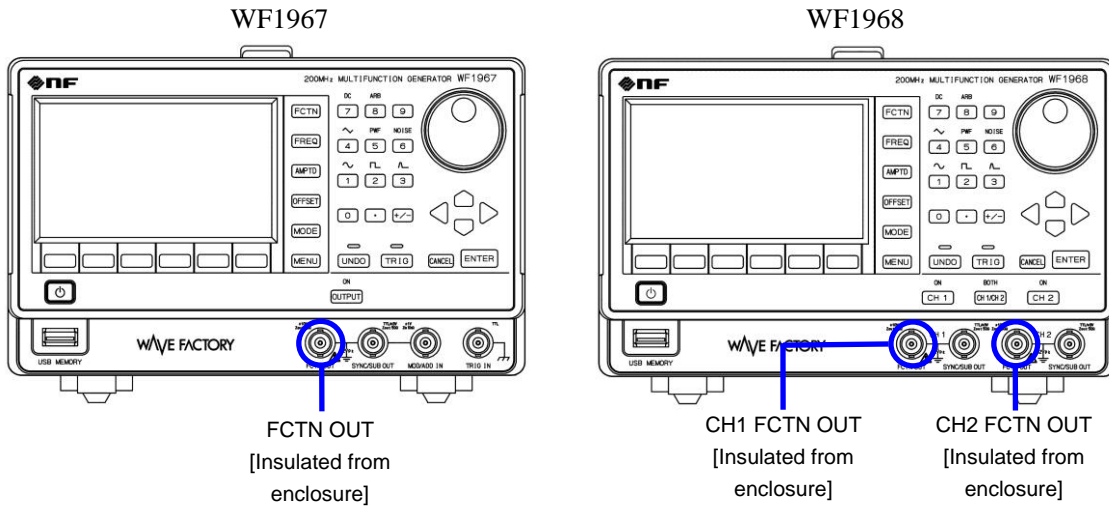

This is the main output.

As a mechanical switch is used to turn the waveform output on or off, chattering may occur when turning the output on/off, and this may cause unintended waveforms to be output. If you do not desire it, always keep the waveform output on, and use the trigger burst oscillation and gate oscillation to start/stop the oscillation. P.4-93

#### ■ Output Characteristics

Output voltage	Maximum $\pm 10V$ /open
Output impedance	50 $\Omega$
Load impedance	0 $\Omega$ or higher (short-circuit protection provided)
Signal GND	Insulated from the enclosure (maximum 42Vpk). In WF1968, also insulated between channels (maximum 42Vpk)

### 3.2.2 Synchronization/Sub-output (SYNC/SUB OUT)

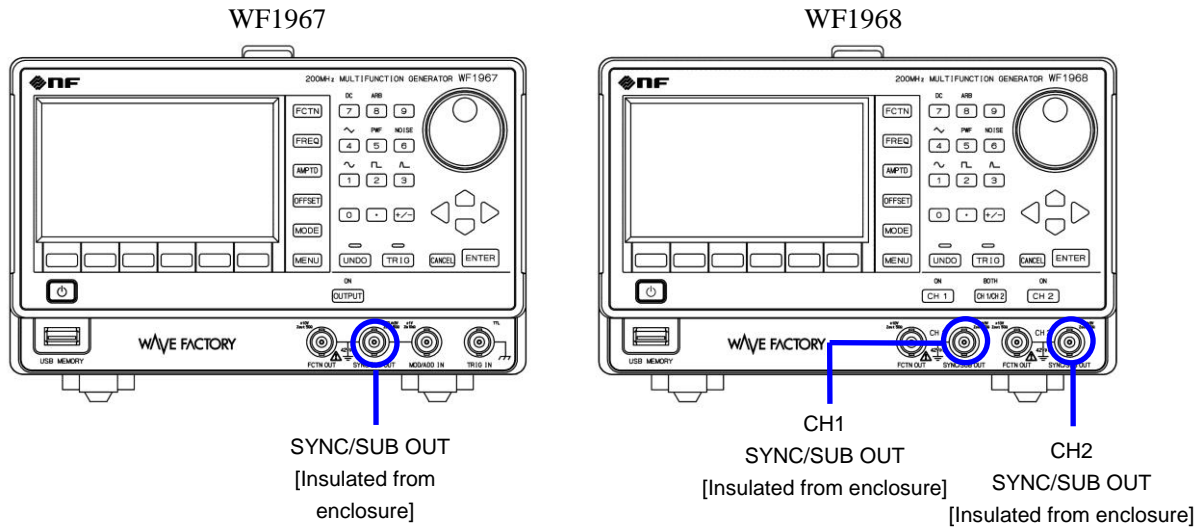

A synchronization signal is output according to the secondary waveform/internal modulation signal, waveform or oscillation status. This signal can be used as the synchronization signal for oscilloscope. As shown in the following table, the output signal can be selected according to the oscillation mode.

Table 3-1 Signals Selectable for Synchronization/Sub-output

Oscillation Mode	Selectable output signal
It is not Modulation mode or modulation source is external	<ul style="list-style-type: none"> <li>Reference phase synchronization signal</li> <li>Secondary waveform signal (maximum -3V to +3V/open) Amplitude and offset may be set as desired within the range specified above. ☞ P. 4-50</li> </ul>
Modulation mode and modulation source is internal ☞ P.4-59	<ul style="list-style-type: none"> <li>Reference phase synchronization signal</li> <li>TTL level signal synchronized with internal modulation signal</li> <li>Internal modulation signal (maximum -3V to +3V/open) Amplitude and offset may be set as desired within the range specified above.</li> </ul>
Sweep Oscillation Mode ☞ P.4-79	<ul style="list-style-type: none"> <li>Reference phase synchronization signal</li> <li>Sweep X drive signal (-3V to +3V/open) Amplitude and offset may be set as desired within the range specified above.</li> <li>TTL level signal synchronized with sweep, marker signal mixing possible</li> </ul>
Burst Oscillation Mode ☞ P.4-91, P.4-96 P.4-100, P.4-104	<ul style="list-style-type: none"> <li>Reference phase synchronization signal</li> <li>TTL level signal synchronized with burst oscillation</li> </ul>

■ About reference phase

The reference phase is the phase of the internal signal as a reference on the oscillator operates. The value set in the reference phase to phase [Phase] will be output are added. Channel 1 and channel 2,

WF1968 are separate.

Reference phase for the modulation source is an internal modulation, there is in addition to the main output, signal that the value set in the modulation phase [ModPhs] has been added will be used in actual modulation.

#### ■ About reference phase synchronization signal

The reference phase synchronization output, it is the duty of 50% of TTL level logic signal that rises at zero degrees of reference phase. By changing the phase setting, can change the phase between the reference signal and the phase synchronization waveform output.  P.4-30

At high frequencies, actually comes out phase difference at 0 ° set by the difference in propagation delay time of the output circuit of the main waveform output and synchronous / sub output. Especially when the 20V range, main waveform output signal in addition to the following cases of 4V range will be delayed about 5ns. These phase differences can be adjusted by the phase setting of.

#### ■ Output Characteristics

Output voltage	TTL level (low: 0.4V or lower, high: 2.7V or higher), -3V to +3V/open
Output impedance	50Ω
Load impedance	50Ω or higher recommended
Signal GND	Same potential as the same channel waveform output, insulated from the enclosure (maximum 42Vpk). In WF1968, also insulated between channels (maximum 42Vpk)

### 3.2.3 External Modulation/Addition Input (MOD/ADD IN)

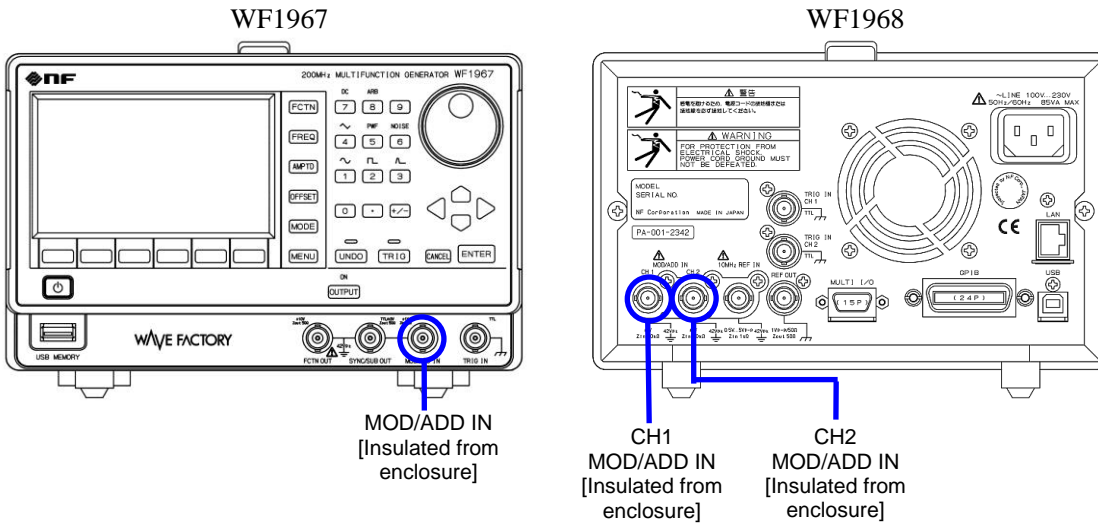

When the modulation source is external in the modulation mode except FSK and PSK, an external modulation signal is input. In the FSK or PSK modulation mode, the external trigger input is used as external modulation signal input.

When not used as external modulation signal input, this terminal can be used as the external addition signal input to the waveform output. The gain of external addition is x0.4, x2, or x10.

External modulation input ☞ P.4-59

External addition input ☞ P.4-42

#### ■ Input Characteristics

Input voltage	±1V Full scale
Maximum allowable input	±2V
Input impedance	10kΩ
Input frequency	During Modulation DC to 400kHz (-3dB) During Addition DC to 100MHz (-3dB)
Signal GND	Same potential as the same channel waveform output, insulated from the enclosure (maximum 42Vpk). In WF1968, also insulated between channels (maximum 42Vpk)

## 3.2.4 External Trigger Input (TRIG IN)

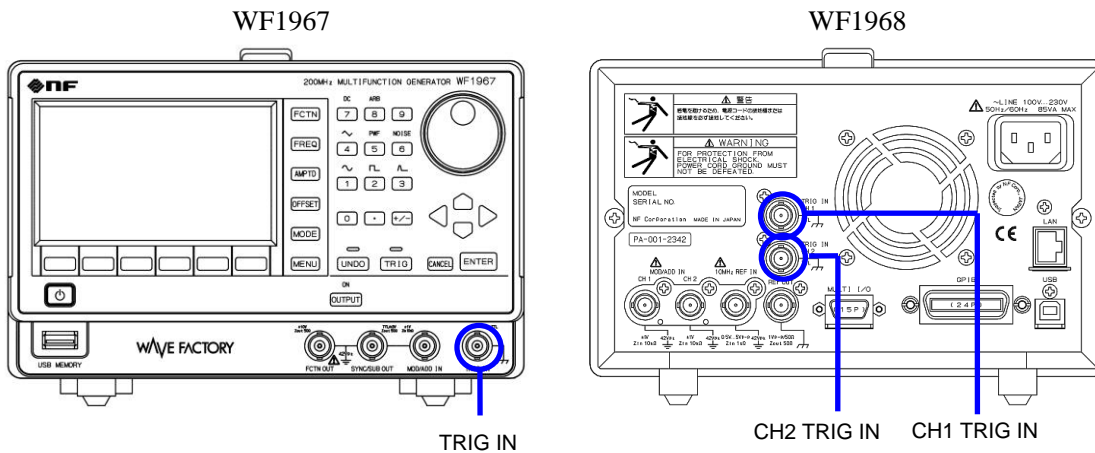

This terminal can be used as external trigger input in the following cases. The polarity setting can be changed.

- Start trigger of single sweep ☞ P.4-77
- Start trigger of gated single sweep ☞ P.4-77
- Start trigger of trigger burst oscillation ☞ P.4-95
- Gate of gate oscillation ☞ P.4-99
- Trigger of triggered gate oscillation ☞ P.4-103

It can also be used as the external modulation input for FSK and PSK. ☞ P.4-59

#### ■ Input Characteristics

Input voltage	TTL level (low: 0.8V or lower, high: 2.6V or higher)
Maximum allowable input	-0.5V to +5.5V
Input impedance	10k $\Omega$ , pull up to +3.3V
Signal GND	Same potential as the enclosure

### 3.2.5 External 10MHz Frequency Reference Input (10MHz REF IN)

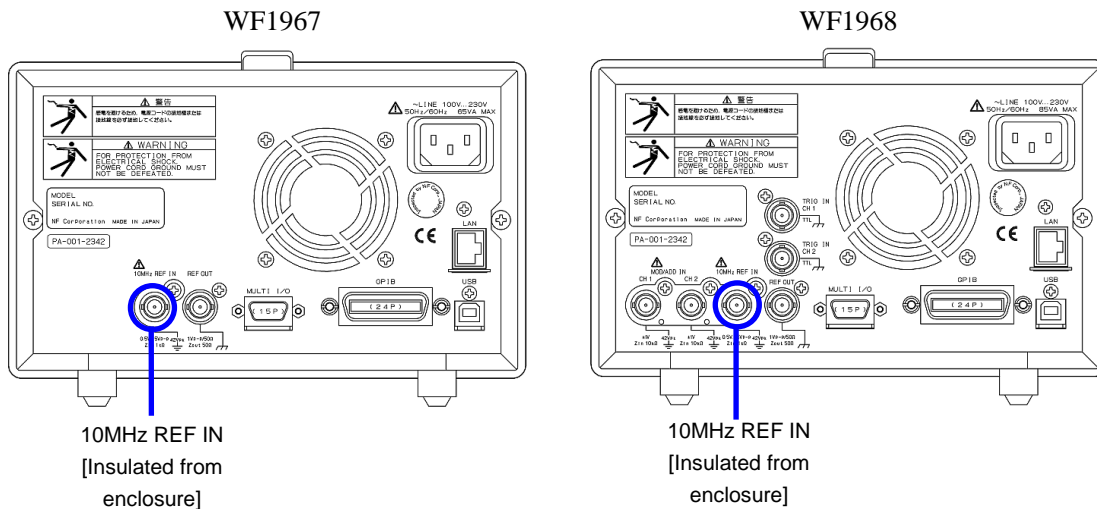

This terminal can be used for the following purposes.

- When frequency accuracy higher than the frequency accuracy specification of this product is required, or when you want to use the same frequency reference as a different signal generator  
Input the 10MHz reference signal from an external frequency standard.

Turn on the external frequency reference setting to enable. [P.10-4](#)

- To unify the frequency and phase of multiple WF1967/WF1968 units

Connect the frequency reference output of the master unit to the external 10MHz frequency reference input of the slave WF1967/WF1968.

Set the frequency of each unit to the same value.

Also, enable the external frequency reference of the slave equipment, and perform the phase synchronization on the master unit. [P.9-4](#)

The frequency accuracy of the connected WF1967/WF1968 units is all the same as that of the master unit.

An external frequency standard can be used as the master unit.

■ Input Characteristics

Input voltage	0.5Vp-p to 5V p-p
Maximum allowable input	10Vp-p
Input impedance	1kΩ, AC coupling
Input frequency	10MHz (±5ppm(±50Hz))
Input waveform	Sine or square wave (50±5% duty)
Signal GND	Insulated from the enclosure and each channel waveform output (maximum 42Vpk)

✓ Check

Do not input any signal to External 10MHz Frequency Reference Input to prevent malfunction.

3.2.6 Frequency Reference Output (REF OUT)

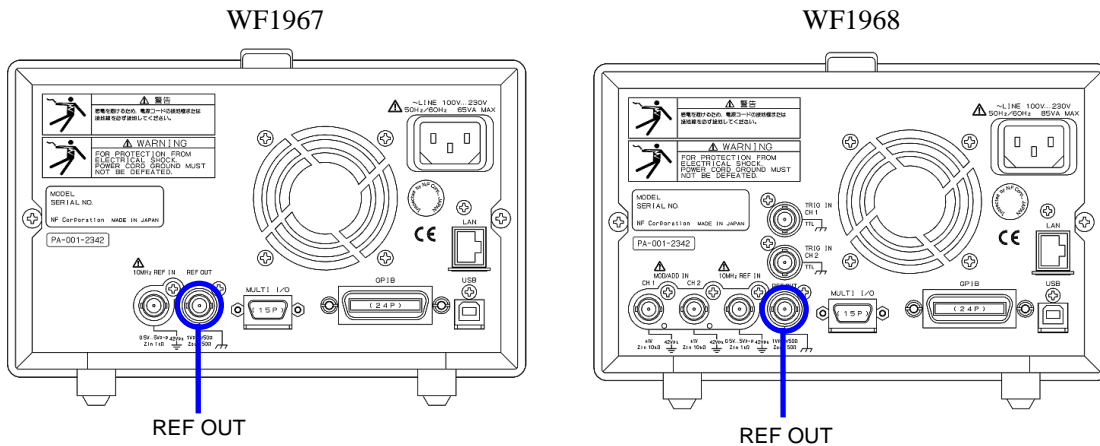

This terminal is used to unify the frequency and phase of multiple WF1967/WF1968 units.

Connect the frequency reference output of the master unit to the external 10MHz frequency reference input of the slave WF1967/WF1968. P.9-2

■ Output Characteristics

Output voltage	1Vp-p / 50Ω
Output impedance	50Ω, AC coupling
Output frequency	10MHz
Output waveform	Square wave
Signal GND	Same potential as the enclosure

✓ Check

Do not connect any equipment other than WF1967, WF1968, and the equipment specified by NF Corporation to the frequency reference output.

The special signal that is output from this terminal during synchronization may make the operation of such connected equipment unstable.



3.2.7 Multi-I/O (MULTI I/O)

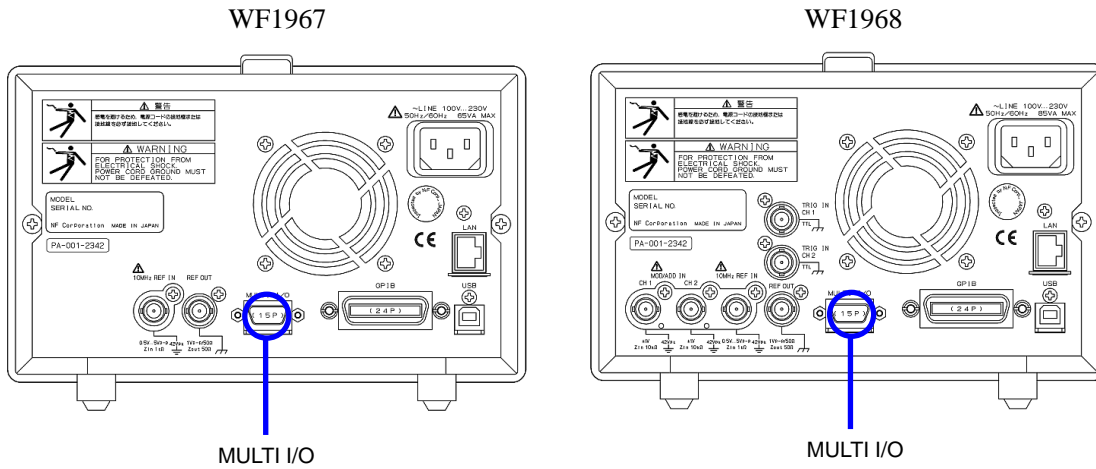

This feature can be used for sweep and sequence control. It outputs the step synchronization code for the sequence.

■ Control Input for sweep oscillation mode

Sweep oscillation can be controlled as follows using 3 bit logic input. [P.4-81](#)

Start	Starts sweep from beginning with falling input. ORed with external trigger input.
Stop	Stops sweep by falling input.
Hold/Resume	Pauses sweep by falling input during a running sweep. Resumes sweep from the paused point by falling input during a stop.

■ Control Input for sequence oscillation mode

Sequence oscillation can be controlled as follows using 4 bit logic input. [P.11-11](#)

Start or State Branch	You may choose Start control or State branch control. It starts the sweep from the beginning by falling input by Start selected. OR operation with external trigger input. It will branch to the designated step by low level input at the end of the step by State branch selected.
Stop	Stops the sequence by falling input.
Hold/Resume	The sequence pauses by falling input during a running sequence. Resumes sequence from the paused point by rising input during a stop.
Event Branch	Branches to the designated step by falling input.

This outputs the 4 bit step synchronization code specified for each step in Sequence Oscillation Mode.

✓ Check

To prevent malfunction due to exogenous noise when not using the multi-I/O connector, it is recommended that the control input be set to prohibited. ☞ P.4-81

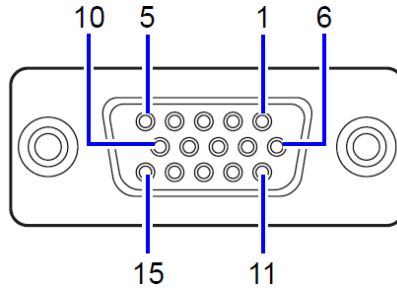

Figure 3-5 Multi-I/O connector pin configuration diagram

Table 3-2 Multi-I/O connector pin assign

Pin No.	I/O	Sweep Oscillation Mode	Sequence Oscillation Mode	Optional cable color and marking(s)
1	Output	Not in use	Step synchronization code D0(LSB)	Light brown and Black
2	Output	Not in use	Step synchronization code D1	Light brown and Red
3	Output	Not in use	Step synchronization code D2	Yellow and Black
4	Output	Not in use	Step synchronization code D3(MSB)	Yellow and Red
5	Output	Not in use	Not in use	Bright green and Black
6	GND	-	-	Bright green and Red
7	GND	-	-	Gray and Black
8	GND	-	-	Gray and Red
9	(Reserved)	Do not connect anything.	Do not connect anything.	White and Black
10	GND	-	-	White and Red
11	Input	Not in use	Event Branch	Light-brown and Black Black
12	Input	Hold/Resume	Hold/Resume	Light-brown and Red Red
13	Input	Stop	Stop	Yellow and Black Black
14	Input	Start	Start or State branch	Yellow and Red Red
15	Input	Not in use	Not in use	Bright green and Black Black
Shell	-	-	-	Bright green and Red Red

Caution: Pin no. 9 is set to +5V for manufacturing tests. It is not intended for use by end users. Do not connect it to anything as it may cause the product to become unstable.

## ■ I/O Characteristics

Input voltage	TTL level (low: 0.8V or lower, high: 2.6V or higher)
Maximum allowable input	-0.5V to +5.5V
Input impedance	10k $\Omega$ , pull up to +5V
Output voltage	TTL level (low: 0.4V or lower, high: 2.7V or higher)
Signal GND	Same potential as the enclosure
Connector	Mini-Dsub 15pin

The connection cable is optional. Please contact NF Corporation or dealer for details.

---

### 3.3 Cautions on Floating Ground Connection

The signal ground of the BNC terminals for FCTN OUT, SYNC/SUB OUT, and MOD/ADD IN is shared, but since it is insulated from the enclosure (ground potential), it can be connected to the equipment that has a different potential. Moreover, when the equipment is mounted in a rack, the signal ground is not affected by the potential of the rack.

In WF1968, the above-mentioned BNC terminals are also insulated between channels.

Further, the signal ground of the 10MHz REN IN is also insulated from the enclosure. Therefore, noise caused by ground-loop does not affect the connection with a frequency standard.

Nor does noise caused by ground-loop affect the connection even when synchronously connecting multiple units of WF1967 and WF1968.

Note that, in all cases, the floating voltage should be limited to 42Vpk (DC + AC peak) or lower to prevent electric shocks.

The other signal grounds are all connected to the enclosure. The enclosure itself is connected to a protective conductor terminal of the power supply input.

---

#### **⚠ WARNING**

To prevent electric shocks, do not apply a voltage exceeding 42Vpk (DC + AC peak) between the ground of the BNC connectors insulated from the enclosure and the enclosure.

Also, do not apply a voltage exceeding 42Vpk (DC + AC peak) between the grounds of the BNC connector groups insulated from the enclosure. "BNC connector groups" indicate multiple BNC connectors that are connected to a common ground.

If such a high voltage is applied, the internal voltage limiting elements will try to reduce the voltage, but a too high voltage may cause the product to be burned.

---

---

#### **⚠ CAUTION**

If a difference in potential exists between the ground of a BNC connector insulated from the enclosure and the enclosure, do not short-circuit the hot side of that BNC connector and the enclosure. This may damage the product.

---

---

#### **⚠ CAUTION**

If a difference in potential exists between the grounds of BNC connectors, do not short circuit these BNC connector grounds. This may damage the product.

---

■ Cautions on floating ground connection for WF1967

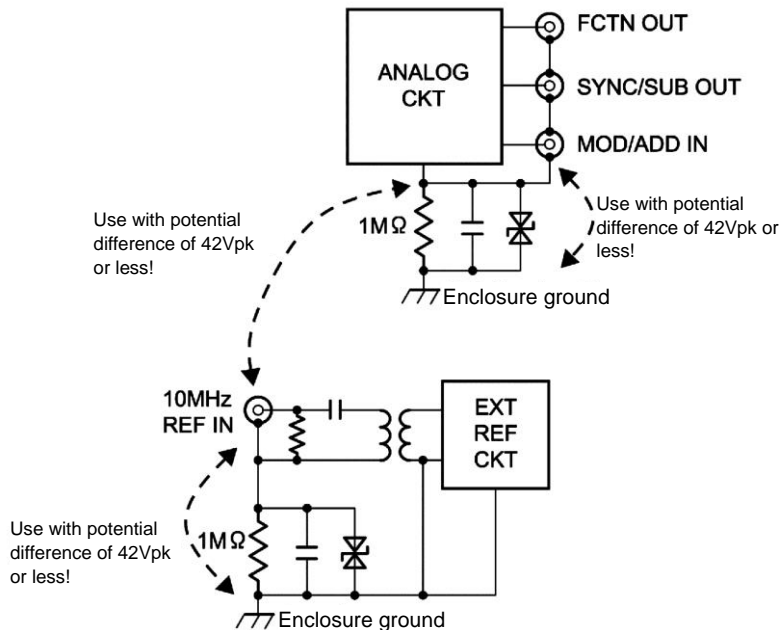

Figure 3-6 Cautions on floating ground connection for WF1967

■ Cautions on floating ground connection for WF1968

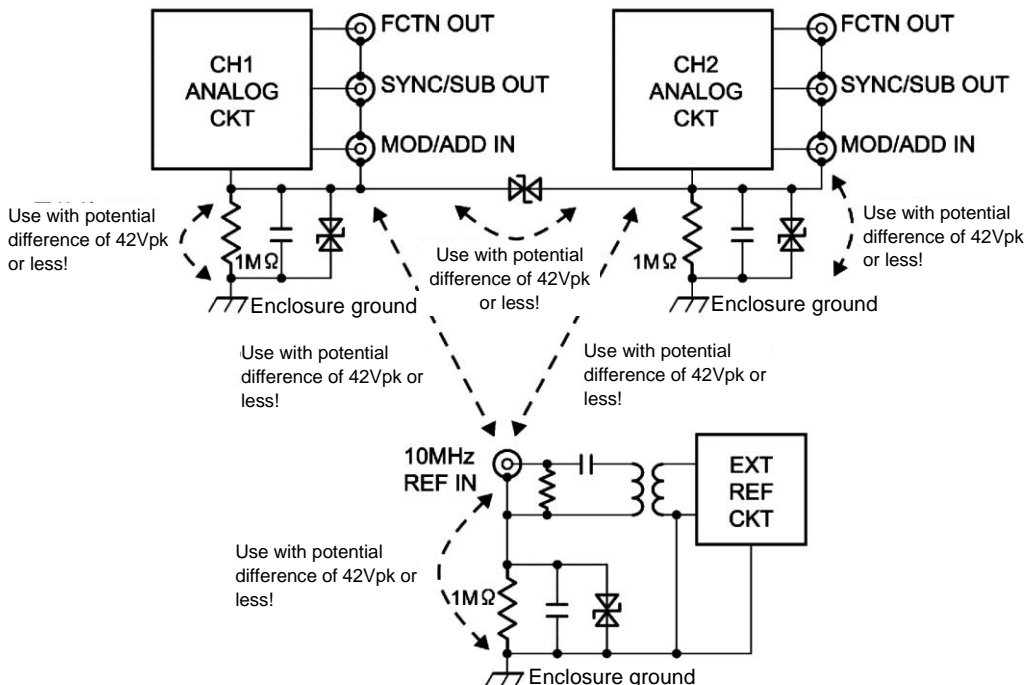

Figure 3-7 Cautions on floating ground connection for WF1968

MEMO

## 4. Basic Operations

4.1	Power On/Off and Restoration of Settings .....	4-2
4.2	Screen Configuration and Operation .....	4-6
4.3	Basic Settings and Operations.....	4-12
4.4	Setting for Main Items .....	4-26
4.5	Using Variable Parameter Waveforms .....	4-52
4.6	Using Arbitrary Waveforms .....	4-53
4.7	Setting and Operation of Modulation.....	4-54
4.8	Setting and Operation of Sweep .....	4-71
4.9	Setting and Operation of Burst.....	4-88

## 4.1 Power On/Off and Restoration of Settings

### 4.1.1 How to Turn Power On/Off

#### ■ Power-on operation

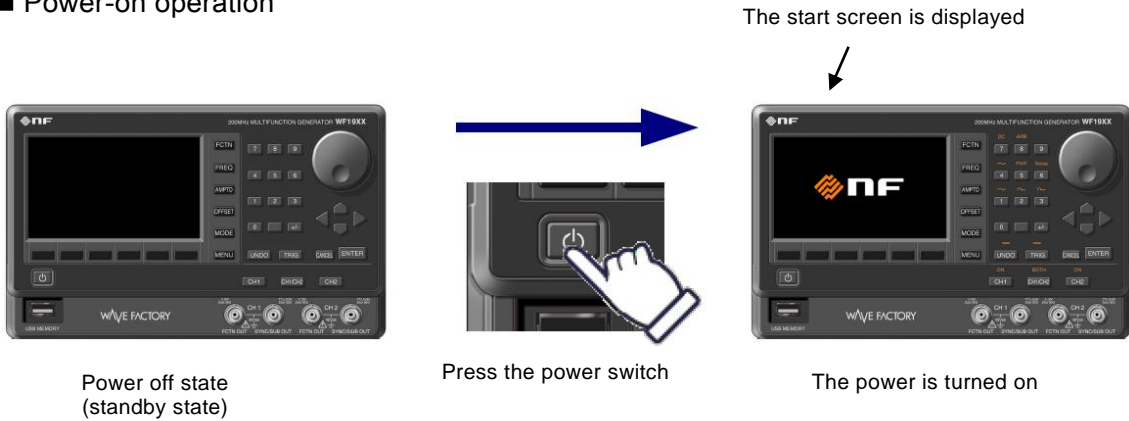

Once the power is turned on, a self test is executed, and then the equipment becomes operable.

#### ■ Power-off operation

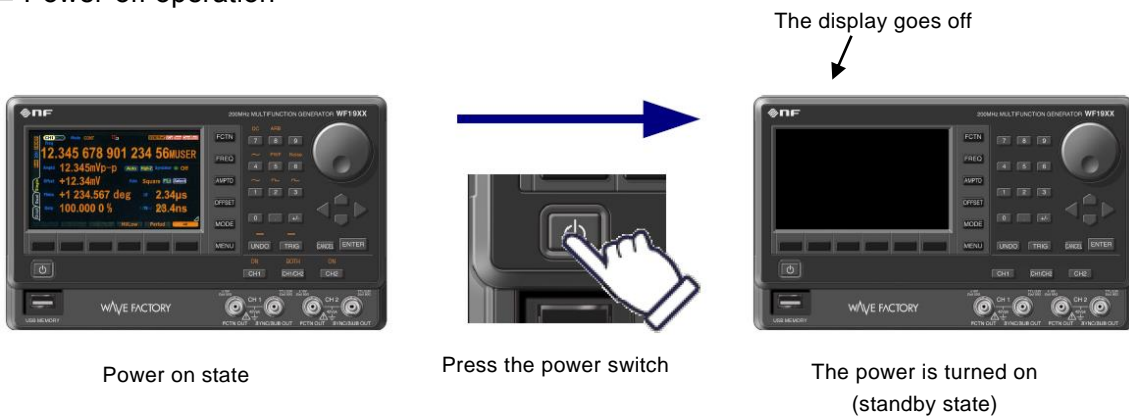



### 4.1.2 Restoration of Settings at Power-on

When the power is on with the power switch, the settings before the previous time the power was switched off are restored. The output on/off at power on can be set on the Utility. P.4-24

However, if the power is directly cut off while the power is on, the settings are set to the contents of the setting memory number 1 when the power supply is resumed.

#### a) Restoration of settings when the power switch is turned on/off while the power supply is on

The most general case is illustrated below.

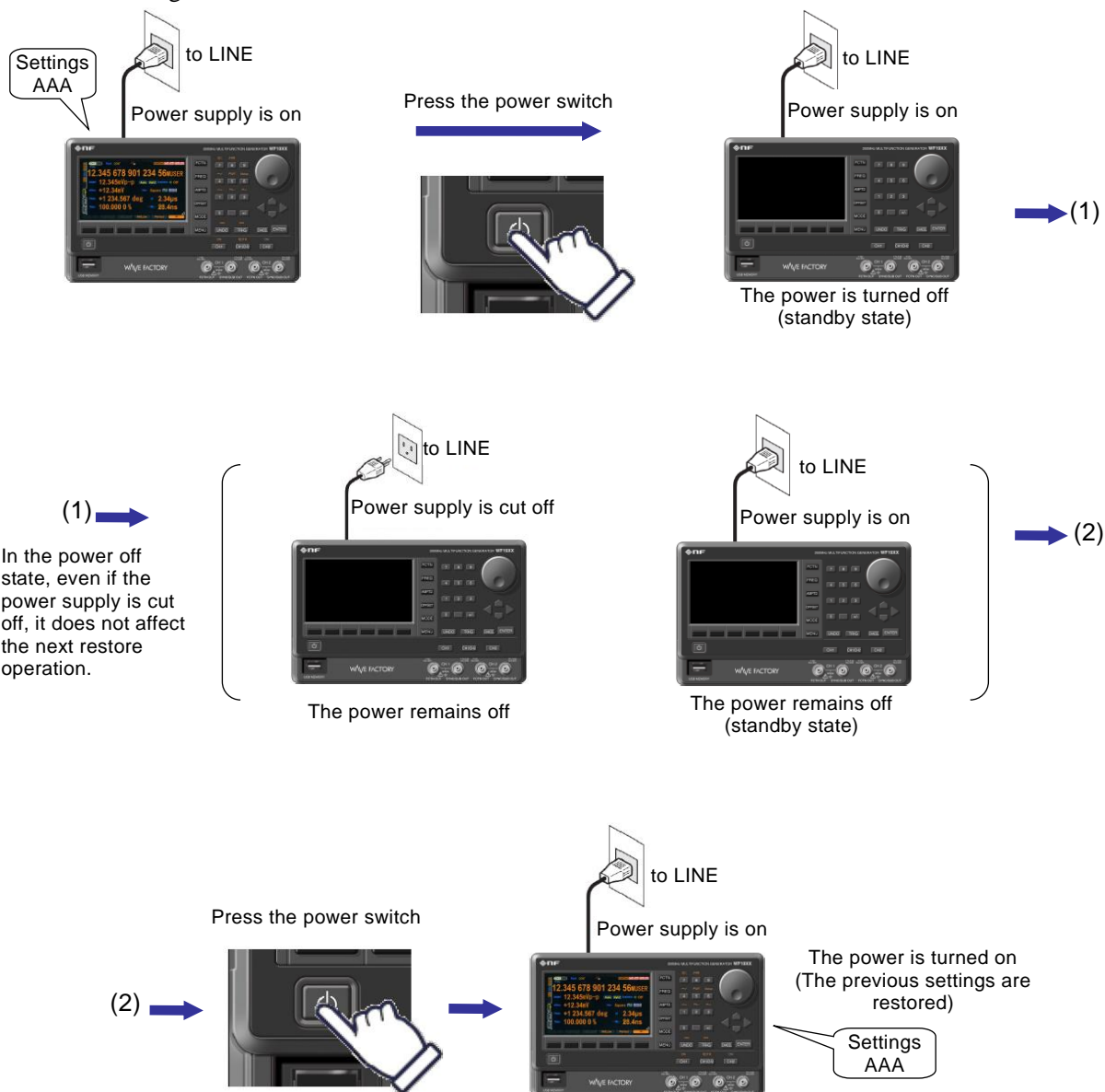

While the power is off, if the power supply is cut off due to the disconnection of the power cord or the shutoff of the connected breaker, this does not affect the restore operation the next time

the power is turned on again.

- The settings before the previous power-off are restored.
- The output on/off setting at power on can be changed on the Utility. ☞ P.4-21
- The Sequence Oscillation mode and Sequence state (restarts from beginning in Run/Hold) are also restored.

✓ Check

The settings immediately before the power-off can only be restored if the power is turned off using the power switch.

A sequence must already be saved in order for it to be restored.

**b) Restoration of settings at power supply on/off**

This is the case when you collectively turn on/off the power supply for this product and other devices which are mounted in a rack.

When the power supply is cut off while the power is on, the power is automatically turned on the next time the power supply is resumed.

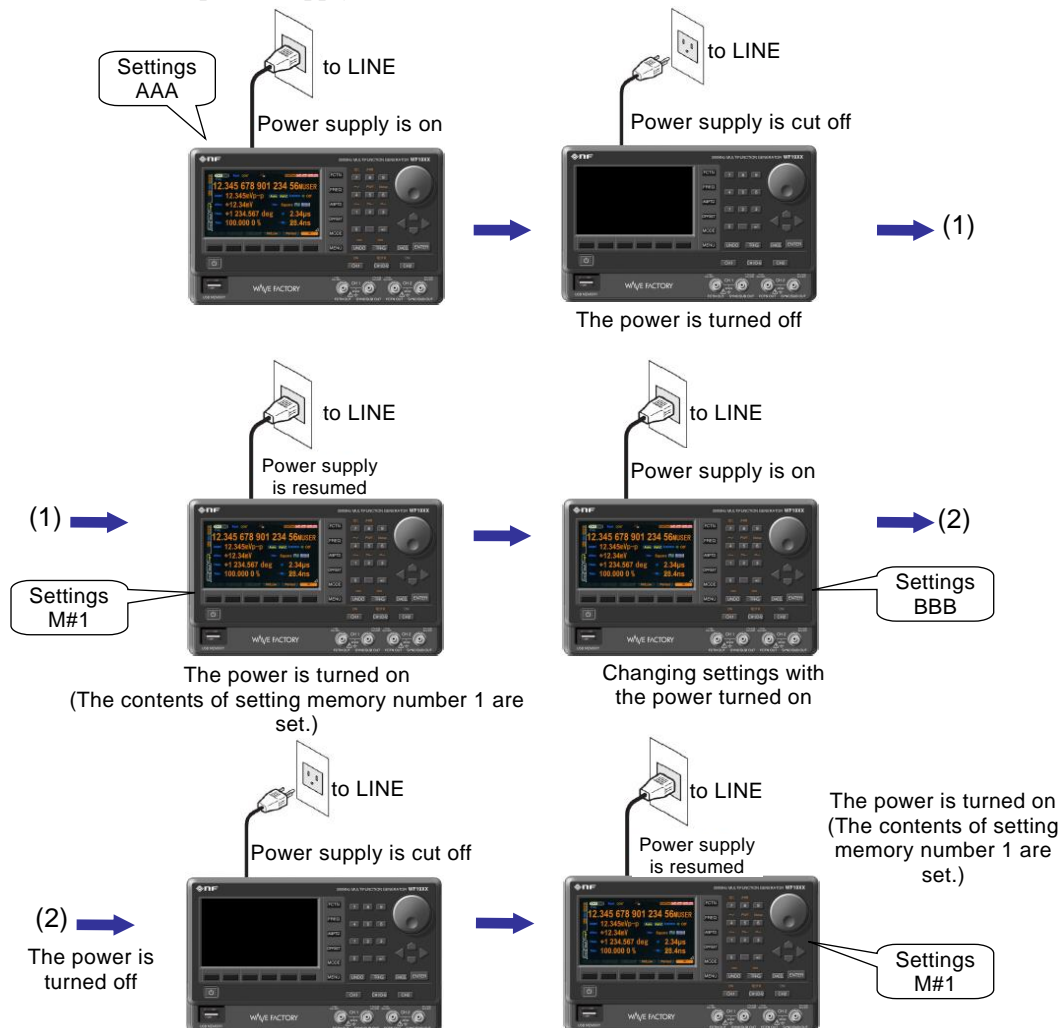

- The settings before the power-off are not restored.
- The contents of setting memory number 1 are set. ↗ P.5-2
- The output on/off setting at power on can be changed on the Utility. ↗ P.4-21
- The unit can be set to start in Sequence Oscillation mode on the Utility. ↗ P.4-21
- In this case, the sequence stored in sequence memory 1 will automatically start.

✓ Check

As the settings before the power supply is cut off are not restored, specify the contents of setting memory number 1 in advance if needed. ↗ P.5-2  
A sequence must already be saved in order for it to be restored.

## 4.2 Screen Configuration and Operation

### 4.2.1 Screen Configuration

The LCD screen consists of three areas, as shown in the following figure.

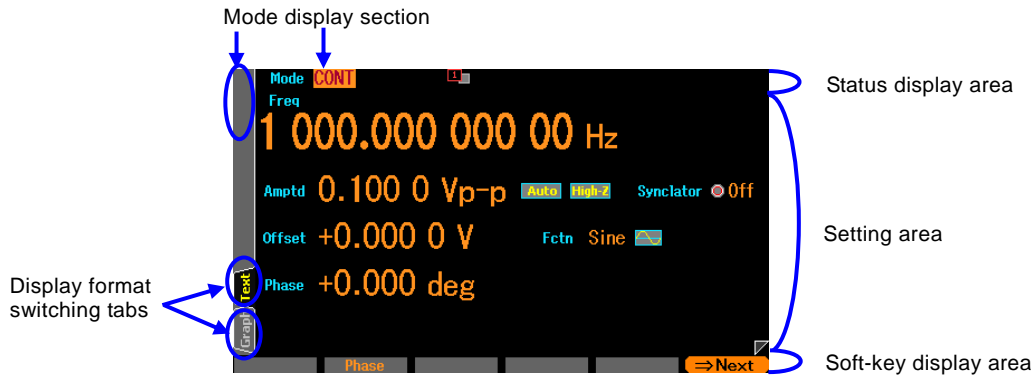

#### ■ Status display area

Displays the status of the product. The following items are displayed.

- Uncalibrated status **UCal**  
Displayed when the calibration information of the product is lost due to a problem, and the prescribed performance cannot be maintained. As this indicates a failure, please contact NF Corporation or Dealer.
- Overheating status **Temp**  
Displayed when the internal temperature of the product is abnormally high. If this status is displayed when the product is used at an ambient temperature of 40°C or less, it indicates a failure, so please contact NF Corporation or Dealer.
- Remote state **USB**, **GPIB**, **LAN**  
Displayed when the product is controlled via USB, GPIB or LAN(Optional).
- External frequency reference status **Ref**  
Displays whether a valid signal is input or not, when the external frequency reference is enabled.

External frequency reference status      **USB Ref**      **UCal**      **Temp**  
 Remote state      **USB**      **GPIB**      **LAN**



■ **Mode display section**

Displays the oscillation mode and the channel mode (WF1968 only) of this product.

- Oscillation mode

The current oscillation mode is displayed.  
 CONT (continuous oscillation)/MODU (modulated oscillation)/  
 SWEEP (sweep oscillation)/BURST (burst oscillation)

For details on the oscillation mode setting see P.4-27

- Channel mode (WF1968 only)

The current channel mode is displayed.  
 INDEP (independent)/2PHASE (2-phase)/  
 2TONE (constant frequency difference)/RATIO (constant frequency ratio)/  
 DIFF(differential output)/DIFF2(voltage doubler output)

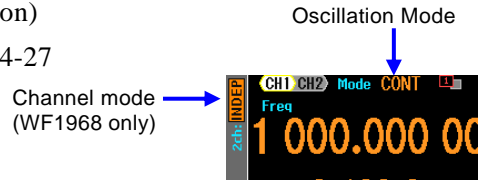

For details on the channel mode setting see P.8-2

■ **Setting area**

This area is used to display and set the various parameters.

When multiple display formats can be selected, the display format switching tabs are displayed on the left side of the screen. P.4-8

If the setting screen has multiple pages, use the Next soft-key to change pages.

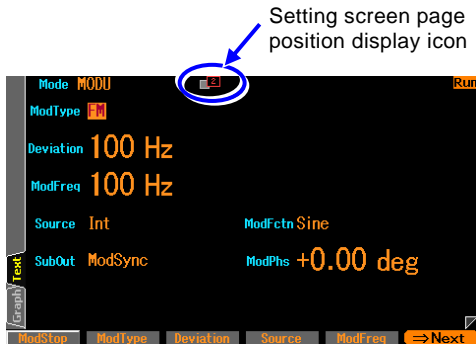
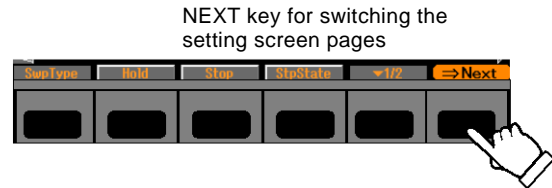

If there are multiple setting screens, an icon at the top center of the screen will indicate the currently displayed page.

In the example on the left, there are two setting screens and the second page is currently displayed.

■ **Soft-key display area**

This area displays the functions of the soft-keys which are allocated according to the situation.

If six or more soft-keys are allocated, “▼ n/m” is displayed on the right-most soft-key. This indicates that the set of soft-keys belonging to the current setting screen consists of m stages in total, and that the set for the nth stage is currently displayed. When you press this right-most key, the soft-key set for the next stage is displayed.

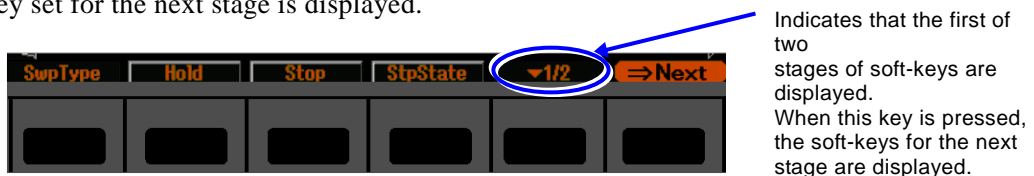

### 4.2.2 Switching Display Format with Tabs (To Display Waveform Graph)

When multiple display formats can be selected, the display format switching tabs are displayed on the left side of the screen. For example, if the [Graph] tab screen is displayed, you can set the parameters while checking the image of the output waveform.

#### a) Display format types

The following three types of display formats are provided on the Oscillator screen.

##### ■ Text display [Text] (WF1967) or [Single] (WF1968)

Displays the settings for one channel in text format



##### ■ Graph display [Graph]

Displays the settings for one channel in both text and graph formats. You can grasp the image of the output waveform.

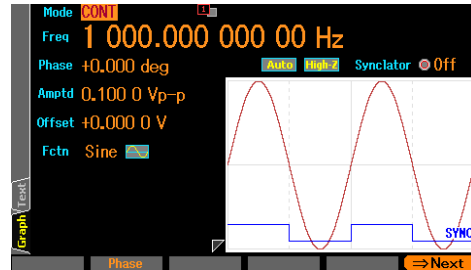

##### ■ 2-channel simultaneous display [Dual] (WF1968 only)

The settings of channel 1 and channel 2 in text format are displayed up and down.



The channel to be set can be switched by using the CH1/CH2 key.

**b) To switch the display format**

The Single tab screen is displayed



1. In the left example, the Single tab screen is displayed. On this screen, the settings are displayed in text format.

The Graph tab is selected



2. Use the arrow keys or the modify knob to select the Graph tab.

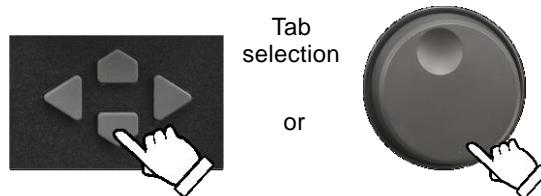

The Graph tab screen is displayed

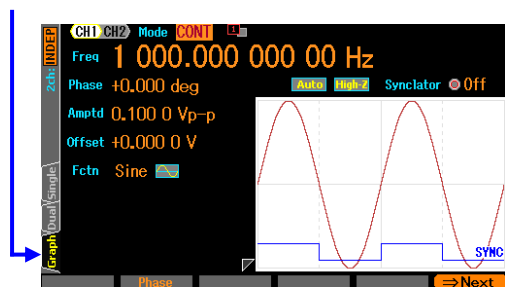

3. Press the ENTER key to switch to the Graph tab screen. On this screen, you can set the parameters while checking the image of the output waveform.



✓ Check

In WF1968, the display can be switched between 2-channel simultaneous display and 1-channel display by using the tab.

### 4.2.3 To use USB flash memory(Switching with tab)

In the store / recall screen of setting, arbitrary waveform, and sequence settings, switch the operation target by tab selection to internal memory or USB flash memory.

#### a) To switch the storage and reading destination

When USB interface is not used, it will appear as "DISK" when USB flash memory plugged to the front panel on the screen. Select the USB tab and press the ENTER key, target will change to USB memory.

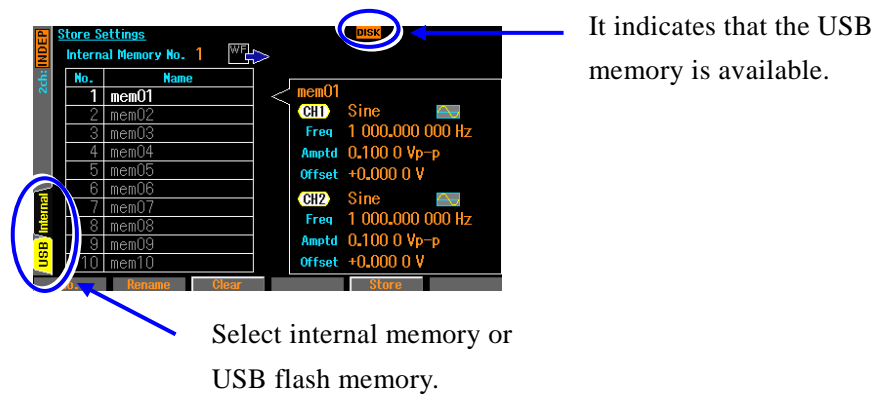

It indicates that the USB memory is available.

Select internal memory or USB flash memory.



### 4.2.4 Top Menu

Arbitrary waveform editing, various system settings, saving and recalling settings and others can be done by selecting the desired item from the top menu.

#### a) To display the top menu

Pressing the MENU key displays the following top menu window.

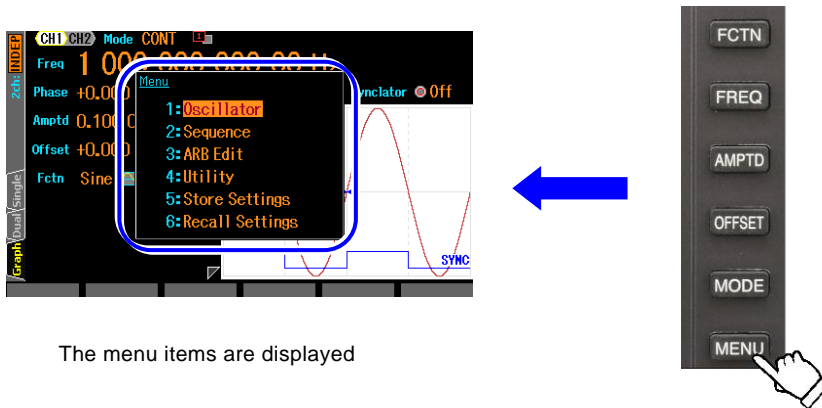

The menu items are displayed

Select the desired item with the arrow keys or the modify knob and then press ENTER key. With the top menu window open, specify the menu item using the numeric keypad [1] to [6].

#### b) Operations available using top menu items

For each item, the following settings and operations can be performed.

##### ■ Oscillator

Opens the Oscillator setting screen where you can perform almost all settings and operations other than arbitrary waveform editing.

##### ■ Sequence

Performs a Sequence Oscillation. [P.11-2](#)

##### ■ ARB Edit

Arbitrary waveform editing can be done. [P.7-3](#)

##### ■ Utility

Various settings and operations can be done. [P.4-21](#)

##### ■ Store Settings

Saves the settings to memory. [P.5-2](#)

##### ■ Recall Settings

Recalls the settings from memory. [P.5-4](#)

## 4.3 Basic Settings and Operations

### 4.3.1 To Change Frequency, Amplitude, and Other Values

a) To change a value with the up/down arrow keys (or the modify knob)

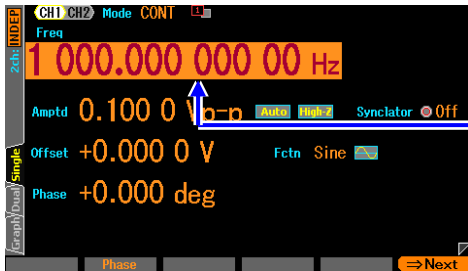

The frequency is selected  
The current frequency value is displayed

1. Select the desired item with the arrow keys or the modify knob. In the left example, the [Frequency] field is selected.

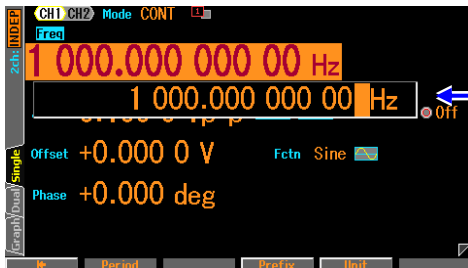
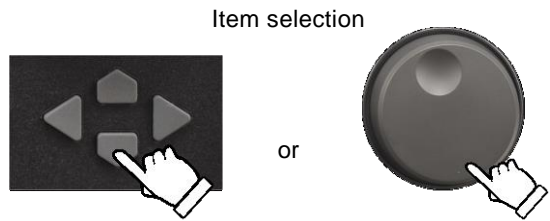

The input field is opened

2. Press the ENTER key to open an entry field to change the current value. In this state, you can enter a value using the numeric keypad.



The 1 kHz digit is to be changed.

3. Press the left/right arrow keys to move the cursor to the digit to change the value. In the left example, the cursor is moved to the 1kHz digit.

Moving the cursor



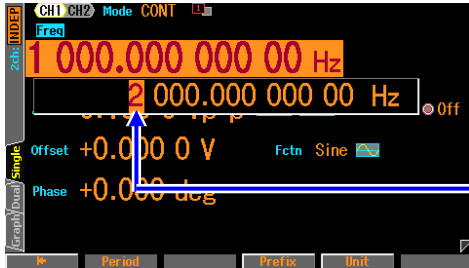

The value of the digit is now 2.

- Increment or decrement the value of the digit using the up/down arrow keys or the modify knob. In the left example, the value is changed to 2 kHz. The change is immediately reflected to the output.

Incrementing/decrementing the value



or

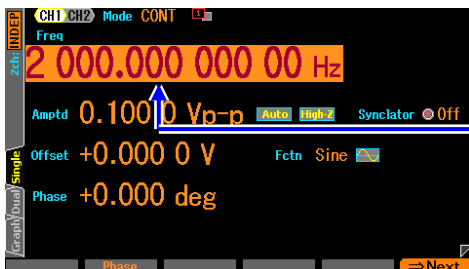

The input field is closed

- Press the ENTER key to close the input field.



If you press the CANCEL key instead of ENTER key, the changed value is discarded and the setting before the change is restored.

b) To change a value with the numeric keypad [0]...[9]



The frequency is selected. The current frequency value is displayed.

1. Select the desired item with the arrow keys or the modify knob. In the left example, the [Frequency] field is selected.



Item selection



or

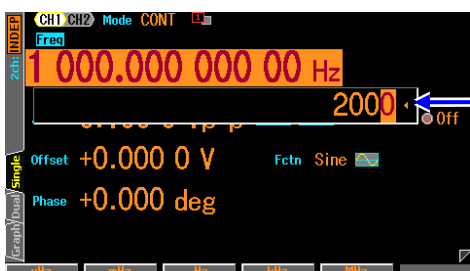

The input field is opened and a value is input

2. Press the numeric keypad to open an entry field and enter the numeric value. While inputting numeric values, the left arrow key serves as the delete key, and the right arrow key as the zero insert key.

Inputting values

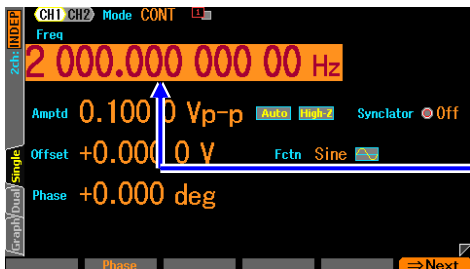

The setting is changed, and the input field is closed.

3. Press the ENTER key or the unit key (soft-key) to set the input value and reflect it to the output. If you press the ENTER key, the value is set without prefixes such as "k" or "m."



or



✓ Check

While inputting numeric values, the left arrow key serves as the delete key, and the right arrow key as the zero insert key.

✓ Check

If a setting item is displayed on a soft-key, you can open the input field for that item by pressing that soft-key.

## 4.3.2 To Change Waveforms



1. When the FCTN key is pressed, waveforms which can be selected will lit on the numeric keypad. Current waveform is flashing. At the same time, a selection list of waveforms will open.



2. Pressing the key directly below the lighting waveform will select that waveform and reflect it in the output. For example, in the image shown to the left, pressing the [2] key will select the Square wave. Another method is to choose the selection list with the arrow keys or modify knob and then press ENTER to apply the settings.

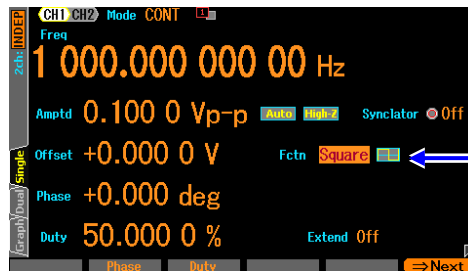

The waveform is set to square wave

### 4.3.3 Shortcut Keys for Changing Basic Parameters

The selection list or input field for waveform, frequency, amplitude, DC offset, and oscillation mode can be immediately opened by using the corresponding basic parameter shortcut key.

#### Frequency

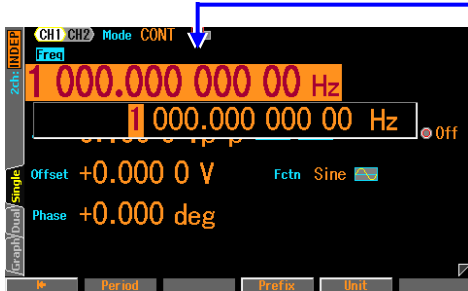

The frequency input field is opened

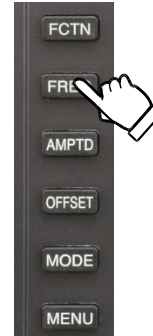

#### Amplitude

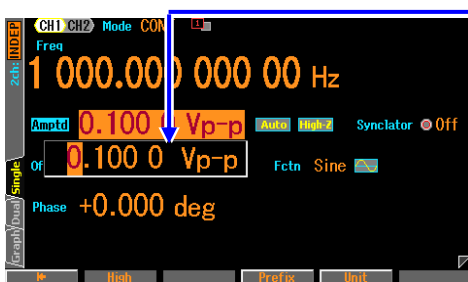

The amplitude input field is opened



#### DC Offset

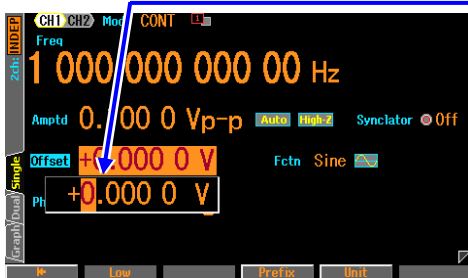

The DC offset input field is opened



#### Oscillation mode

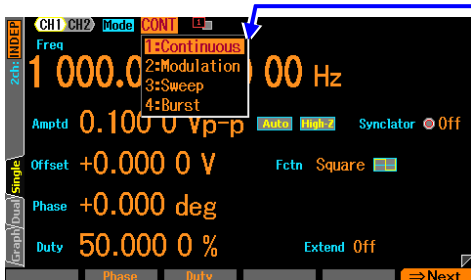

The Oscillation mode entry field is opened



#### 4.3.4 Functions of ENTER/CANCEL/UNDO Key



##### ■ Functions of ENTER key

The ENTER key can be used to perform the following actions.

- Open the input field or selection list for the selected item.
- Set the value input from the numeric keypad.
- Perform the function of the button displayed on the screen.

##### ■ Functions of CANCEL key

The CANCEL key can be used to perform the following cancellations.

- Close an input field or selection list.
- Discard the value input from the numeric keypad.
- Restore the value changed by using the modify knob.
- Close a setting window or dialog box.

##### ■ Functions of UNDO key

The UNDO key can be used to restore the settings changed by using the ENTER key or the modify knob. This key also can restore the setting change that has been automatically executed as the result of the user's operation.

When you press the UNDO key again immediately after the undo operation, the setting before the undo operation is restored.

Note that undo may not work for some operations.

### 4.3.5 Change Display Unit

**a) To change the unit prefix (k, m, M, etc.)**

Frequency is used as an example here. For amplitude and pulse width, you can use a similar way.

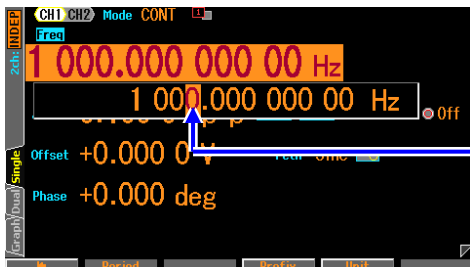

The input field is opened

1. Select frequency and then press the ENTER key to open the input field.

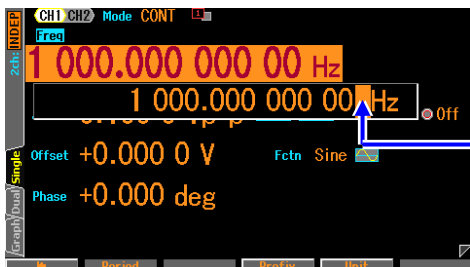

Pressing [Prefix] moves the cursor to before "Hz"

2. Press the [Prefix] soft-key to move the cursor to before "Hz". You can also press the right arrow key to move the cursor to before "Hz".

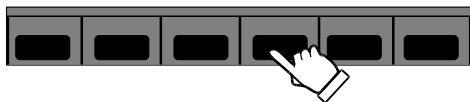

3. You can use the up/down arrow keys or the modify knob to change the unit to MHz, kHz, Hz, mHz, or uHz. This just changes the display unit and decimal point position, and the setting value itself does not change.

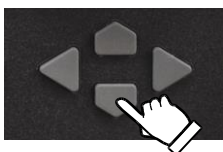

Changing prefix  
or

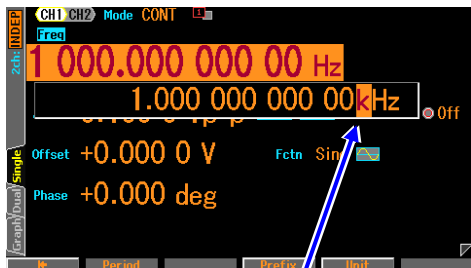

kHz



MHz



**b) Change Vp-p, Vrms, user-defined unit, etc.**

Amplitude is used as an example here. For frequency and pulse width, you can use a similar way.

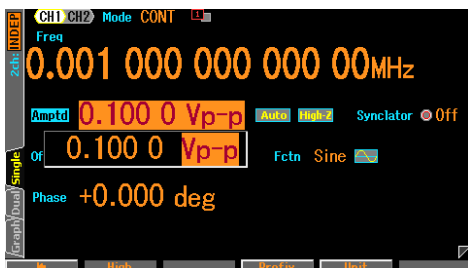

1. Select amplitude and then press the ENTER key to open the input field.

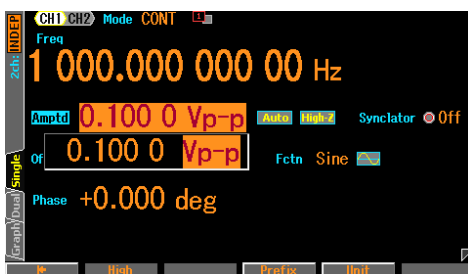

2. Press the [Unit] soft-key to move the cursor to "Vp-p". You can also press the right arrow key to move the cursor to "Vp-p".



3. You can use the up/down keys or the modify knob to change the units to Vrms, dBV, or a user-defined unit (in the case of sine wave and load impedance Hi-Z). This just changes the display unit and numeric value, but the output value itself does not change.

Changing unit



or



Vrms display



dBV display

Also refer to the followings:

- Changing the frequency, cycle time ☞ P.4-28, P.4-29.
- Changing the amplitude unit (Vp-p, Vpk, Vrms, dBm, dBV) ☞ P.4-33.
- Changing the pulse width and duty ☞ P.4-46.
- Setting user-defined units ☞ P.12-2.

### 4.3.6 CH1/CH2 Switching Key and Active Channel (WF1968 Only)

Each time the CH1/CH2 switching key is pressed, the channel to be set is switched alternately.

This key is disabled on the setting screens that are not dependent on the channel.

The channel that is to be set is called the "active channel" in this product. In the burst oscillation and other modes, the TRIG key works for the channel whose display is active. Active settings are saved even when moving to setting screens that are not dependent on the channel.



CH1 active  
(CH1 is the Setting target)



CH2 active  
(CH2 is the Setting target)

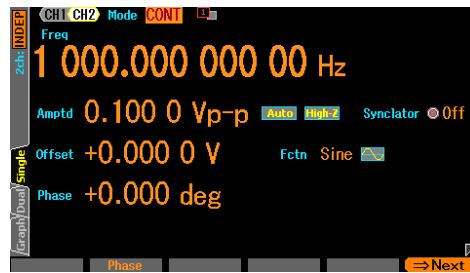
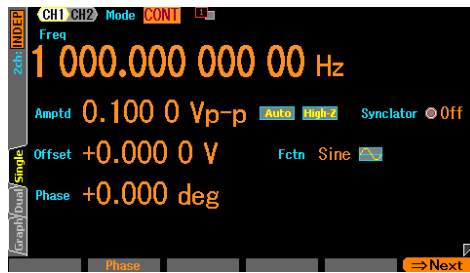
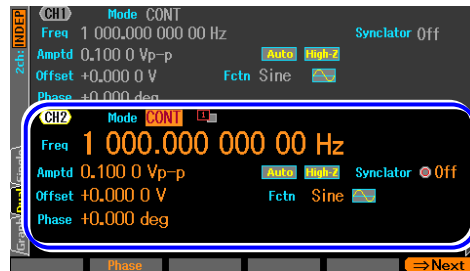

The current active channel is displayed at the top left corner of the Oscillator screen

### 4.3.7 Operations Available on Utility

#### a) Displaying the Utility menu



When the MENU key is pressed, the top menu opens. Then, select Utility. This opens the Utility menu.

#### b) Utility menu

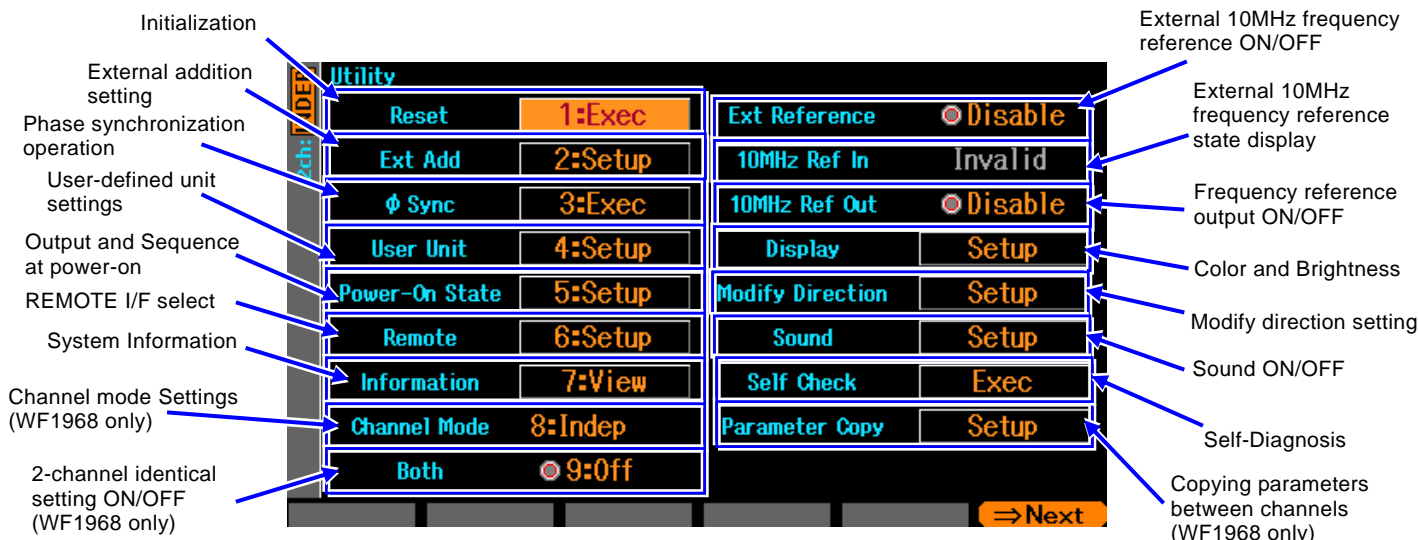

- Initialization [Reset]
 

Performs a reset of the settings. Restoring the settings to the initial state will turn off the output for continuous oscillation, sine wave, 1kHz, and 0.1Vp-p/open. [P.4-23](#)
- External Addition Settings [ExtAdd]
 

Sets the external addition gain. Available settings are off, 0.4x, 2x, and 10x. [P.4-42](#)
- Phase Synchronization Operation [φ Sync]
 

Handles the synchronization between multiple units when they are connected together and synchronization between channels on the WF1968. [P.8-6](#), [P.9-4](#)
- User Defined Unit Settings [User Unit]
 

Sets the user defined units. [P.12-3](#)
- Output and Sequence at power-on [Power-On State]
 

Determines the output on/off settings when the power is turned on and the automatic

- sequence start on/off settings for when the power is restored after being cut off. ☞ P.4-24
- REMOTE I/F select [Remote]  
Selects GPIB and USB and set the GPIB address. Also displays the USB ID. ☞ P.13-2
  - System Information [Information]  
Displays the firmware version and last modified date. ☞ P. 13-3
  - Channel Mode Settings [Channel Mode](WF1968 only)  
Sets the type of operating mode when 2 channels are linked. Options include Independent ☞ P.8-7, 2 phase ☞ P.8-7, Constant frequency difference ☞ P.8-9, Constant frequency ratio ☞ P.8-11, Differential output 1 ☞ P.8-13, Differential output 2 ☞ P.8-14
  - 2 Channels identical setting ON/OFF [Both](WF1968 only)  
Sets whether the same settings are applied to both channels. ☞ P.8-5  
Use the arrow keys or modify knob to select the item and press ENTER to set or change each item.
  - External 10MHz Frequency Reference ON/OFF [Ext Reference]  
Sets permitted or forbidden for the external 10MHz frequency reference. ☞ P.10-4
  - External 10MHz Frequency Reference state display [10MHz Ref In]  
Displays whether the external 10MHz frequency reference signal is valid or not.  
☞ P.10-4
  - Frequency Reference Output ON/OFF[10MHz Ref Out]  
Switches the 10MHz reference output terminal on or off ☞ P. 9-4
  - Color and brightness [Display]  
Sets the display backlighting. ☞ P.13-2
  - Modify Direction Settings [Modify Direction]  
Sets the direction of movement when the modify knob is turned. ☞ P. 13-2
  - Sound ON/OFF [Sound]  
Sets the operation sound. ☞ P.13-3
  - Self Diagnostic [Self Check]  
Performs an internal status check. ☞ P. 13-3
  - Copy Parameters Between Channels [Parameter Copy](WF1968 only)  
Copies the settings between channels. ☞ P.8-3

Each item can also be set or changed by pressing the corresponding number [0]...[9] on the numeric keypad. Use the Next soft-key to switch between the item numbers on the left and right hand side.

### 4.3.8 To Restore Initial Settings

Restore the initial settings from the Utility.

Restoring the settings to the initial state will turn off the output for continuous oscillation, sine wave, 1kHz, and 0.1Vp-p/open.

For a list of the initial settings refer to P.16-2.



1. When you press the MENU key, the top menu is displayed. Select [UTILITY] and press ENTER key. Utility screen opens.

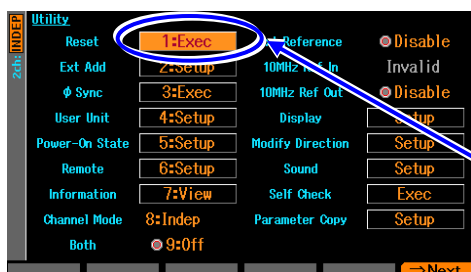

2. Select [Reset] and then press the ENTER key. This initializes the settings.

Select [Reset] and press ENTER.

### 4.3.9 Output On/Off

#### a) Key Operation

Switches the waveform output on/off when pressed (WF1967 has an OUTPUT key, WF1968 has CH1 and CH2 keys). The "ON" lamp above the key will lit when the output is turned on.



Output on/off key

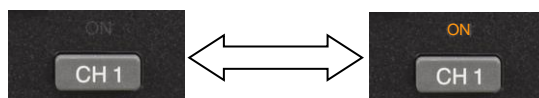

The output terminal is released when the output is turned off. Output impedance is 50Ω when turned on. The synchronization/sub output is always on regardless of the waveform output on/off settings. The on/off setting for the waveform output uses a mechanical switch. This causes chattering to occur when the waveform output is switched on or off. Please use the trigger burst or gate oscillation function when connecting to equipment which might malfunction due to chattering. P.4-93

**b) Power-on settings**

Specifies the waveform output on/off state and/or sequence state when the power is turned on.

The following are the 3 available.

- Off[Off]  
Output is always off.  
Oscillator mode(not sequence mode).

- On[On]  
Output is always on.  
Sequence mode.

- Return to previous settings[Last State]  
This operation depends on how the power was previously shut off.  
If the power was turned off using the power switch on the front panel  
→ The settings before the previous power-off are restored.  
If the power was turned off by disconnecting the power supply  
→ The output will remain off.

Oscillator mode (not sequence mode).

This is the case when you collectively turn on/off the power supply for this product and other devices which are mounted in a rack.

Select the setting on the Utility.

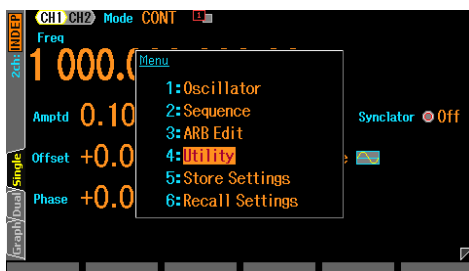

1. When you press the MENU key, the top menu is displayed. Then, press the [UTILITY] soft-key. Utility menu opens.

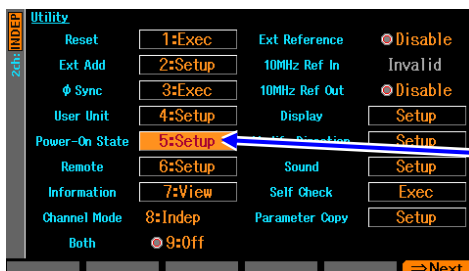

2. Select [Power-On State] and then press the ENTER key.

In the Utility screen, Select [Power-On State] and then press the ENTER key

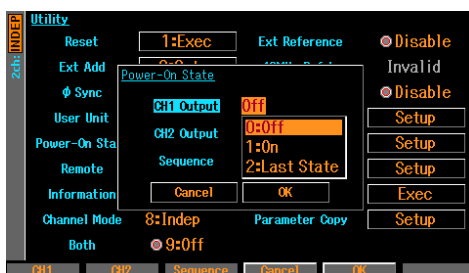

3. When the Power-On State window opens, select the desired output setting and press the ENTER key.  
The selection list of the output settings conditions is opened, so select the desired condition and then press the ENTER key.



4. When the power-on output setting is completed, select [OK], and then press the ENTER key. The change of the power on output setting is applied, and the window is closed. When you do not want to apply the change of the power-on output setting, select [Cancel] and press the ENTER key, or press the CANCEL key.

## 4.4 Setting for Main Items

This section describes how to set the main items that are set in the Oscillator.

When you press the MENU key while another screen is displayed, the Top menu is displayed. Select [Oscillator].

We explain by using the text display screen (1-channel display) in the continuous oscillation mode as an example. There are two settings pages and the main settings can be found on the first page.

### 4.4.1 Text Display Screen in Continuous Oscillation Mode

The screen to set the basic output waveforms.

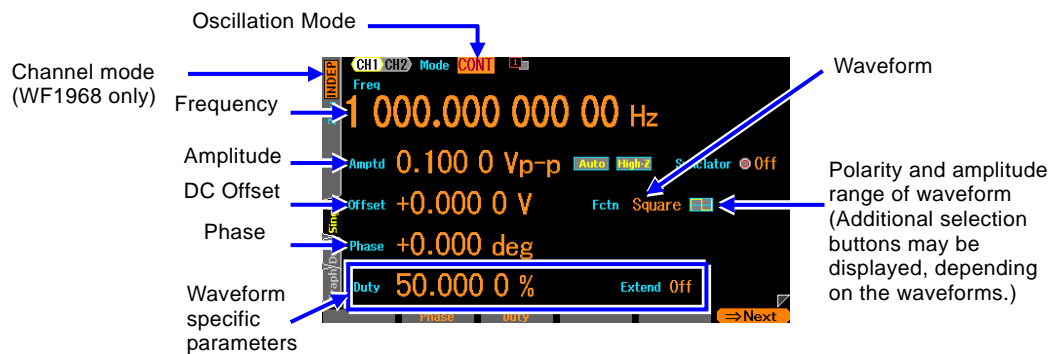



## 4.4.2 To Set Oscillation Mode

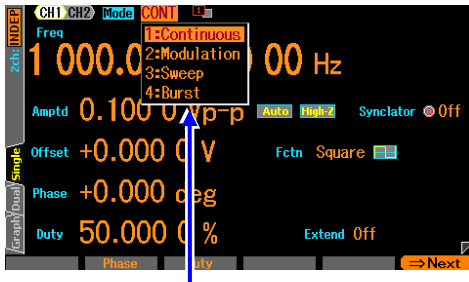
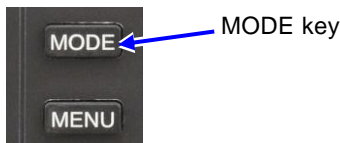

Oscillation mode list

1. Press the MODE key or use the arrow keys and modify knob to select the MODE item. Pressing the ENTER key will open the oscillation mode selection list.

Current  
Oscillation  
Mode

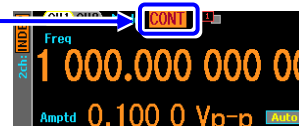

2. Press the MODE key or use the arrow keys and modify knob to select the MODE item. Pressing the ENTER key will open the oscillation mode selection list. Select the desired oscillation mode from the selection list and press the ENTER key to reflect it in the output. You can also enter the number. The mode can also be entered via the number with just the [Mode] field selected (selection list not opened).

### 4.4.3 To Set Waveforms



1. Pressing the FCTN key or using the arrow keys and modify knob to select [Fctn] will cause the selectable waveforms above the numeric keypad to light. At the same time, a selection list of waveforms will open. [Fctn] is displayed at first page.

2. Press the number key corresponding to the desired waveform or use the arrow keys and modify knob to select the waveform and press the ENTER key.

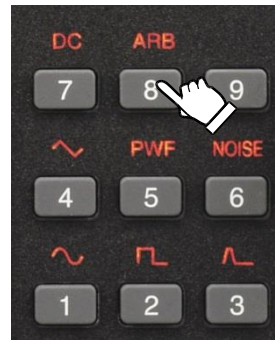

When you set the waveform as arbitrary wave, the arbitrary waveform stored in the main unit is selected. [P.4-53](#)

### 4.4.4 To Set Frequency

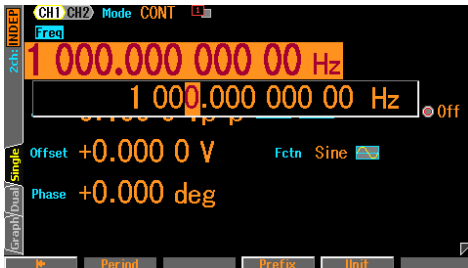

1. Press the FREQ key to open the input field of Frequency. Or, select the [Frequency] field and then press the ENTER key. [Frequency] is displayed at first page. If [Period] is displayed, press the FREQ key again or press the soft-key [Freq]. The display switches to the frequency display.
2. Select the digit to be changed by using the right or left arrow key, and then use the up or down arrow key or the modify knob to increment the value. The change is immediately reflected to the output. Or use the numeric keypad to enter the value. Press the ENTER key or the unit key (soft-key) ([uHz], [mHz], [Hz], [kHz], or [MHz]) to set the input value and reflect it to the output. When the ENTER key is used, Hz is set as the unit.

### 4.4.5 To Set Period

Period can be set instead of Frequency.

The following two methods are available to change from the frequency display to the period display:

○ Use the soft-key [Freq] / [Period]

The input field of Frequency opens. When the current Frequency is displayed, the soft-key [Period] is displayed. Press the soft-key [Period] to open the period input field and changes display from [Frequency] to [Period]. The soft-key [Period] changes to [Freq].

○ Press the FREQ key again

When the shortcut-key FREQ is pressed twice without opening the input field of Frequency, the input field is opened.

While the input field of Frequency or Period is opened, the display switches between Frequency and Period when the FREQ key is pressed.



When the input field of Period appears, set in the same way as the one for Frequency. When a number is entered by using the numeric keypad, the unit key for period setting is displayed on the soft-key. When changed to the period display, the displayed is changed as follows.

Item Name: Frequency → Period

Unit display: Hz → s

Soft-keys: Period → Freq

### 4.4.6 To Set Phase

#### a) Setting procedure

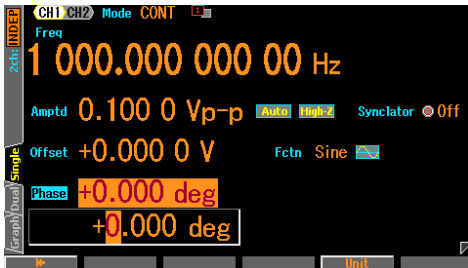

1. Select the [Phase] field and then press the ENTER key to open the phase input field. [Phase] is displayed at first page.
2. Select the digit to be changed by using the right or left arrow key, and then use the up or down arrow key or the modify knob to increment the value. The

change is immediately reflected to the output.

Or use the numeric keypad to enter the value. Press the ENTER key or the unit key (soft-key) ([deg]) to set the input value. When the ENTER key is used, deg is set as the unit.

#### b) Items that can be changed in the phase setting

The following items can be changed in the phase setting.

- The phase difference between the reference phase synchronous output in the Synchronization/Sub-output and waveform output can be changed.

The following figure shows an example of a phase setting of +90 degree. At this time, the zero relative position of waveform output precedes 90 degrees from the rising position of the reference phase synchronous output.

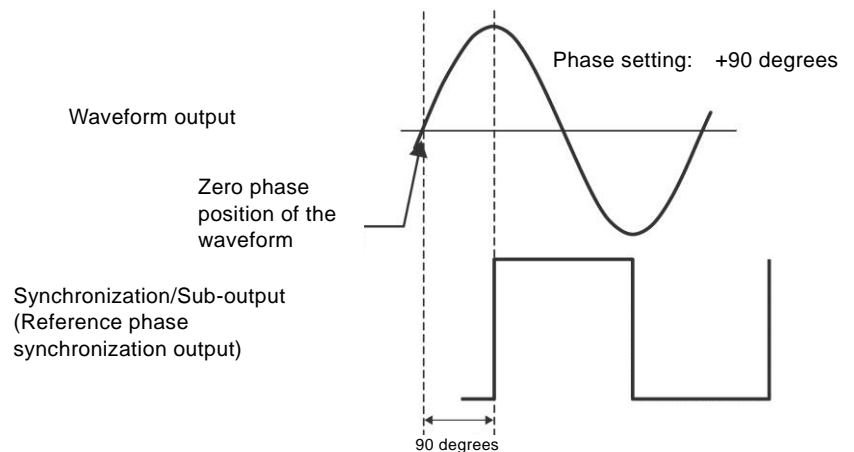

- The oscillation start/stop phase is changed in burst Oscillation or gated sweep.

The following figure shows an example of the burst oscillation at the oscillation start/stop position of +30 degrees. At this time, the oscillation starts at a +30 degree position, and also stops at a +30 degree position.

Burst Oscillation [☞](#) P.4-88, Gated Sweep [☞](#) P.4-76.

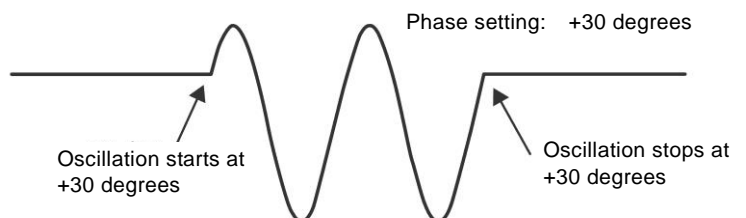

- The phase difference between channels can be changed in synchronous oscillation and 2 phase oscillation (WF1968 only)

The difference between the phase settings of each channel is the phase difference between the channels.

When [Phase setting of CH1 minus Phase setting of CH2] is negative, the waveform of CH2 precedes the waveform of CH1 as shown in the following figure.

For Synchronous Oscillation and 2 Phase Oscillation see

☞ P.8-6, P.8-7

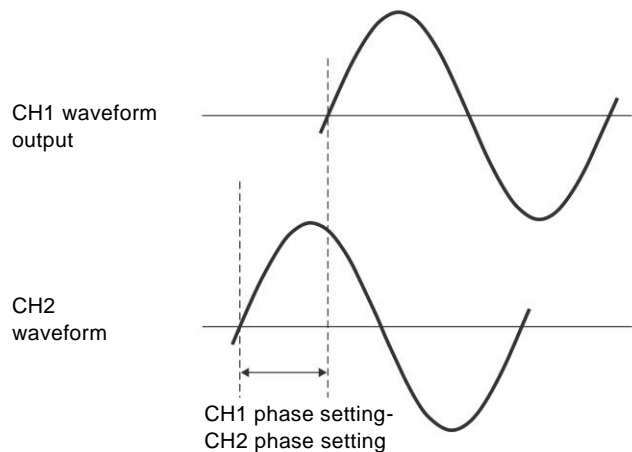

- Phase Difference Between Main and Sub Output Can be Changed (Modulation is off or when using External Modulation)

The difference in phase settings between the main and sub waveforms becomes the phase difference between the outputs. The mutual relationship is the same as explained in the previous section. For Sub Waveform Phase Settings see ☞ P.4-51

#### 4.4.7 To Set the Synclator Function

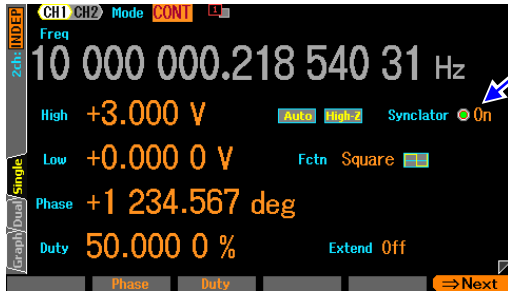

Select [Synclator] and press the ENTER key to turn the Synclator function on or off. Frequency of waveform output and external signal added to TRIG IN will synchronize when the Synclator function is on. In this case, the phase difference between the added external signal and the output signal can be freely adjusted in the [Phase] settings.

#### ✓ Check

It is not the case that if the phase setting is  $0^\circ$  that the phase difference between the added external signal and the output signal will be  $0^\circ$ .

The [Freq] item cannot be changed when the Synclator function is turned on and the current oscillator frequency will be displayed. Synchronization is possible across a range from 20Hz to 10MHz. Loss of synchronization can be checked by the [UnLock] status area in the upper right hand corner of the screen.

This function cannot be used in sweep mode, the FM/FSK/PSK modulation mode, or burst oscillation modes other than auto burst mode.

In the WF1968, the external trigger input of channel 1 may be used to act as the synchronization source for channel 2. Set the Synclator synchronization source [SyncSrc] on page 2 (page 3 when using auto burst) to the [Ch1] instead of [Ext].

### 4.4.8 To Set Amplitude

#### a) Setting procedure

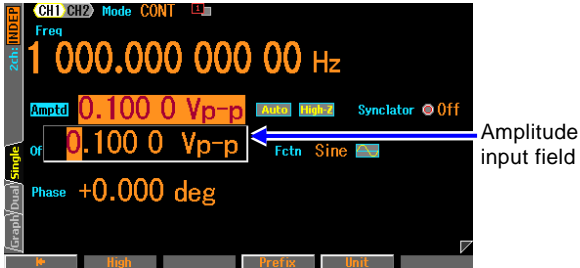

1. Press the shortcut-key AMPTD to open the amplitude input field. Or select the [Amplitude] field and then press the ENTER key.  
[Amplitude] is displayed at the first page. If [High] is displayed in the [Amplitude] field, press the AMPTD key again.

2. Select the digit to be changed by using the right or left arrow key, and then use the up or down arrow key or the modify knob to increment the value. The change is immediately reflected to the output.  
Or use the numeric keypad to enter the value.  
Press the ENTER key or the unit key (soft-key) to set the input value and reflect it to the output.

#### b) To change units (Vp-p, Vpk, Vrms, dBV, dBm, User-defined unit)

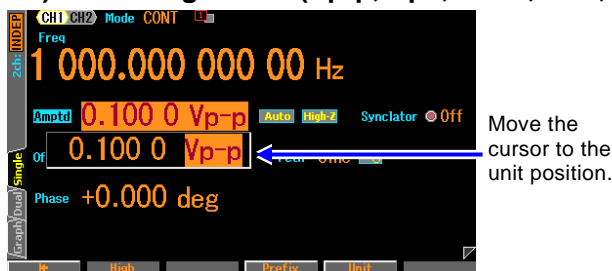

1. When the input field of Amplitude opens, press the soft-key [Unit] to move the cursor to the unit position at the right end.
2. The unit can be changed by using the up or down arrow key/modify knob. Only the display unit is changed without changing the actual output value.

#### c) Available units differ depending on the waveform.

Vp-p, Vpk, Vrms, dBV, dBm, and user-defined units can be used as the units for amplitude. However, the waveforms to which the units can be applied are restricted as follows (DC is excluded from amplitude settings).

Unit	Applied waveform
Vp-p	Standard waveforms with amplitude range of $\pm FS$ and arbitrary waveforms
Vpk	Standard waveforms with amplitude range of $0/+FS$ , $-FS/0$ and arbitrary waveforms
Vrms	Sine wave and noise
dBV	Noise of sine wave. 1 Vrms shall be 0dBV.
dBm	Sine wave and noise. The voltage that is 1mW at the specified load impedance shall be 0dBm. For example, when the load impedance is set as 50 $\Omega$ , 0dBm=223.6mVrms/50 $\Omega$ . It is not available when the load impedance is set as Hi-Z.
User-defined Unit	All waveforms. For user-defined units, <a href="#">P.12-2</a>

**d) Restriction on AC + DC**

The maximum total value of AC amplitude and DC offset is restricted to  $\pm 10V$ /open (110MHz or less) or  $\pm 2V$  /open.

For example, when the AC amplitude is  $5V_{p-p}$ /open, DC offset is restricted to the range from  $-7.5V$ /open to  $+7.5V$ /open. (When the frequency is 110MHz or less)

The maximum value also differs depending on the range setting of output voltage or Ext Add setting.

☞ P.4-40, P.4-43



### 4.4.9 To Set DC Offset

#### a) Setting procedure

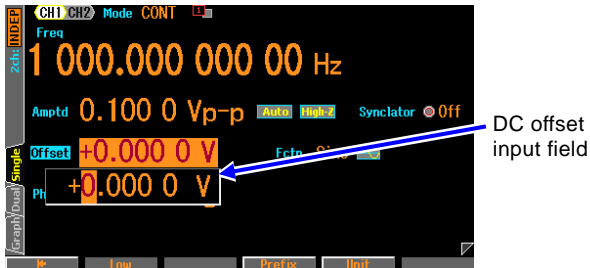

1. Press the shortcut-key OFFSET to open the DC offset input field. Or select the [Offset] field and then press the ENTER key to open the DC offset input field. [Offset] is displayed at the top left on the first page. [Low] is displayed in the [Offset] field. If the low level instead of DC offset is displayed, press the OFFSET key again.

2. Select the digit to be changed by using the right or left arrow key, and then use the up or down arrow key or the modify knob to increment the value. The change is immediately reflected to the output.  
Or use the numeric keypad to enter the value. Press the ENTER key or the unit key (soft-key) to set the input value and reflect it to the output.

#### b) Restriction on AC + DC

The maximum total value of AC amplitude and DC offset is restricted to  $\pm 10\text{V}/\text{open}$  (110MHz or less) or  $\pm 2\text{V}/\text{open}$ .

For example, when the AC amplitude is  $5\text{Vp-p}/\text{open}$ , DC offset is restricted to the range from  $-7.5\text{V}/\text{open}$  to  $+7.5\text{V}/\text{open}$ . (When the frequency is 110MHz or less)

The maximum value also differs depending on the range setting of output voltage or Ext Add setting.

☞ P.4-40, P.4-43

#### 4.4.10 To Set Output Level with High/Low Level

The output level can be set with the top end value (high level) and the bottom end value (low level) of a waveform instead of amplitude and DC offset.

##### a) To change Amplitude/DC offset display to High/Low display

There are the following three methods to change the amplitude/DC offset display to high/low display:

- To change to the high/low display by using the soft-key [High] / [Low]
  - When the input field of Amplitude or DC offset opens, the soft-key [High] or [Low] is displayed. When this soft-key is pressed, the input field of high level or low level opens, and the display is changed from [Amplitude], [Offset] to [High], [Low] respectively.
  - The soft-key [High], [Low] changes to [Ampl], [Offset] respectively. When the soft-key [Ampl], [Offset] is pressed, then the input field of Amplitude or DC offset is opened.
- Press the AMPTD key twice to change to the High/Low display
  - When the shortcut-key AMPTD is pressed twice without opening the input field of Amplitude, the input field of High level is opened. While the input field of high level is open, the display is switched between the amplitude/DC offset as the AMPTD key is pressed.
- Press the OFFSET key twice to change to the High/Low display
  - When the shortcut-key OFFSET is pressed twice without opening the input field of DC offset, the input field of Low level is opened. While the input field of low level is open, the display is switched between the amplitude/DC offset as the OFFSET key is pressed.



High level input field



Low level input field

When the input field of high level or low level is open, the settings are made in the same way as for DC offset. When a numeric value is entered by using the numeric keypad, the unit key for high level/low level setting is displayed on the soft-key.

When changing to the high level/low level display, the display is changed as follows.

Item Name: Amplitude → High, Offset → Low

Unit display: Vp-p, Vpk, Vrms, dBV, dBm, V → V

Soft-keys: High → Ampl, Low → Offset

**b) Restriction on AC + DC**

Depending on the oscillation frequency, high level and low level are restricted to a range of -10V to +10V/open (110MHz or less) or -2V to +2V/open.

The maximum range also differs depending on the range setting of output voltage or Ext Add setting.

☞ P.4-40, P.4-43

### 4.4.11 To Set Waveform Polarity and Amplitude Range

#### a) Setting procedure

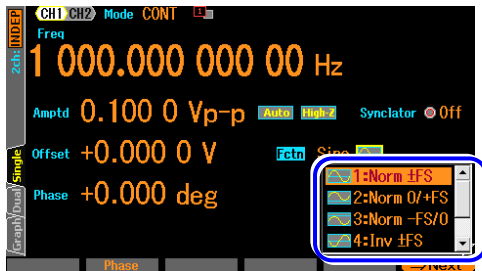

Selection list (soft-key)

1. Selecting the Polarity/Amplitude Range icon to the right of the waveform name display will show the current polarity and amplitude range settings. Press the ENTER key to open the selection list for the polarity/amplitude range.
2. Select the desired polarity and amplitude range from the selection list and press the ENTER key to reflect it in the output. You can also enter the number of the desired polarity and amplitude range displayed in the list on the numeric keypad to reflect it in the output.

#### b) What are polarity and amplitude range

You can reverse the polarity or change the amplitude range to single-polarity for each waveform. The following figure shows the cases with sine waves:

Polarity	Amplitude		
	-FS/0	$\pm$ FS	0/+FS
Normal [Norm]			
Inverted [Inv]			

"Reverse" only reverses a waveform without changing the sign of output DC offset.

✓ Check

The polarity and amplitude range setting are separate settings for each waveform.

### c) How to determine amplitude range

Waveform is changed as follows when Amplitude is changed.

Pay attention how the waveform changes as the Amplitude is changed, and decide the amplitude range.

By default, waveforms which oscillate to both polarities are set to  $\pm FS$  while unipolar waveforms are set to  $0/+FS$ .

#### ■ Example with sine wave and an amplitude range of $\pm FS$

When the amplitude is changed, the amplitude of the waveform changes to positive and negative symmetry based on the DC offset position.

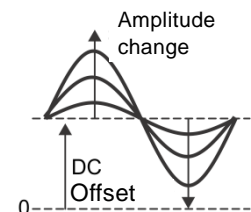

#### ■ Example with a Gaussian pulse and an amplitude range of $0/+FS$

When the amplitude is changed, only the positive peak of waveform will change in reference to the DC offset position. The amplitude will change in reference to the waveform's base.

The amplitude will change in reference to the top of the waveform when the amplitude range is set to  $-FS/0$ .

(including the Gaussian pulse and variable parameter waveforms)

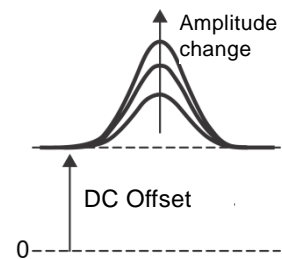

### d) Restriction by amplitude range

- When the amplitude range is  $-FS/0$  or  $0/+FS$ , the maximum amplitude is half of  $\pm FS$ .
- When the amplitude range is  $-FS/0$  or  $0/+FS$ , it is equivalent to use only the upper or lower half of the waveform memory. Therefore, the amplitude resolution power decreases by 1 bit compared with  $\pm FS$ .
- The amplitude range for  $\pm FS$  is set as  $V_{p-p}$ , or set as  $V_{pk}$  for  $-FS/0$  or  $0/+FS$ . Both are the nominal size of peak to-peak of waveform.

### 4.4.12 How to Use Auto Range/Range Hold for Output Voltage

Auto-range is selected by default. The optimum range is automatically selected according to the amplitude and DC offset (including high/low level settings) settings. When the range is changed, a transitional voltage is generated. Therefore, it is controlled so as not to be an excessive voltage. If the transitional voltage generated on range switching is undesirable, you can fix the range. However, amplitude precision and waveform fineness decrease as the amplitude is reduced with the range fixed.

#### a) Setting procedure

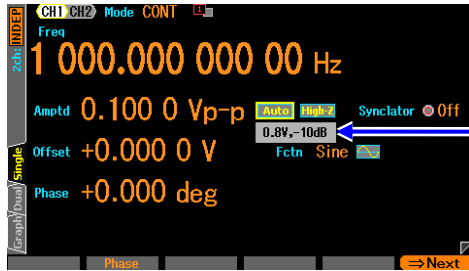

When selecting the range field, the current range is displayed.

1. When the range field is selected, the current range is displayed. It is expressed as a combination of the maximum output voltage [Vp-p] and the amplitude attenuator. When the ENTER key is pressed, the selection list for range processing is opened.

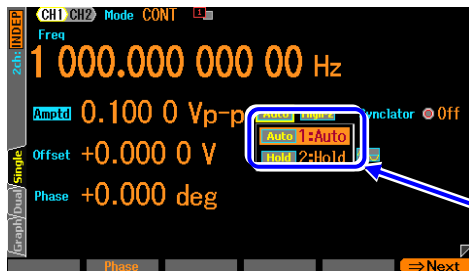

Selection list

2. When [AUTO] is selected, it is set to Auto range. Selecting [HOLD] fixes the range at that time. Select the desired range processing, and then press the ENTER key.

#### b) Maximum values of Amplitude/DC offset for fixed range

When a range is fixed, the maximum values of amplitude and DC offset, and Ext Add gain is fixed as shown in the following table.

Range (Maximum output voltage Vp-p, Amplitude attenuator)	Maximum Amplitude (at no load)	DC offset Max (at no load)	AC+DC Maximum Value (at no load)	External Add gain (Rated $\pm 1V$ )
20V, 0dB	20Vp-p	$\pm 10V$	$\pm 10V$	x10 or Off
20V, -10dB	6.325Vp-p	$\pm 10V$	$\pm 10V$	x10 or Off
20V, -20dB	2Vp-p	$\pm 10V$	$\pm 10V$	x10 or Off
20V, -30dB	0.6325Vp-p	$\pm 10V$	$\pm 10V$	x10 or Off
4V, 0dB	4Vp-p	$\pm 2V$	$\pm 2V$	x2 or Off
4V, -10dB	1.265Vp-p	$\pm 2V$	$\pm 2V$	x2 or Off
4V, -20dB	0.4Vp-p	$\pm 2V$	$\pm 2V$	x2 or Off
4V, -30dB	0.1265Vp-p	$\pm 2V$	$\pm 2V$	x2 or Off
0.8V, 0dB	0.8Vp-p	$\pm 0.4V$	$\pm 0.4V$	x0.4 or Off
0.8V, -10dB	0.253Vp-p	$\pm 0.4V$	$\pm 0.4V$	x0.4 or Off
0.8V, -20dB	0.08Vp-p	$\pm 0.4V$	$\pm 0.4V$	x0.4 or Off
0.8V, -30dB	0.0253Vp-p	$\pm 0.4V$	$\pm 0.4V$	x0.4 or Off

### 4.4.13 To Set Load Impedance

By matching the setting value of the load impedance to an actual loading condition, the amplitude and the DC offset (including the setting according to high level and low level) can be set with the voltage that appears to the load end.

The value of the load impedance can be set to a range of 1Ω-10kΩ, 50Ω or Hi-Z. However, if the setting value of load impedance is changed, only the amplitude setting value and DC offset displayed value are changed. The output voltage when the load is opened does not change.

#### a) Setting procedure

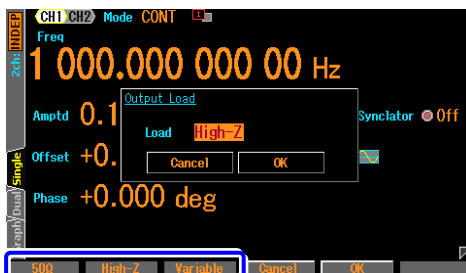

Selection list (soft-key)

1. When the load impedance field at the right of the range field is selected and the ENTER key is pressed, the selection list is displayed.

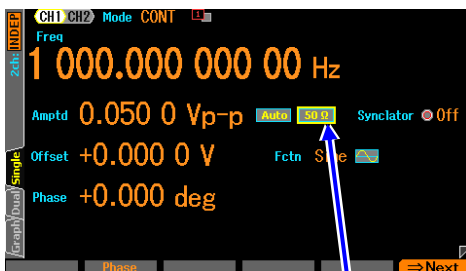

Input field of load impedance is displayed

2. Select the desired load impedance condition, and then press the corresponding soft-key. When [Vari] is selected, the load impedance can be set. In this case, the input field of load impedance value is displayed to the right of the load impedance field. If nothing is changed, press the CANCEL key.

#### b) Conversion formula

Converted by the following formula:

Load Impedance Setting Value:  $R_{load}$  ( $\Omega$ )

Output voltage when load is opened:  $V_{open}$

Output voltage setting value (load end voltage):  $V_{load}$

$$V_{load} = \frac{R_{load}}{50 + R_{load}} \times V_{open}$$

- ✓ Check
  - Output impedance is a constant 50Ω.
  - Neither the output impedance error nor the output voltage error is corrected. The precision specification of the output voltage is the value when no load.

### 4.4.14 To Add External Signal

It is possible to output by adding an external signal to a waveform output.

#### a) To Connect addition signal

Connect an addition signal to the external modulation/addition input (MOD/ADD IN) BNC terminal on the front panel of the WF1967 or on the rear panel of the WF1968.

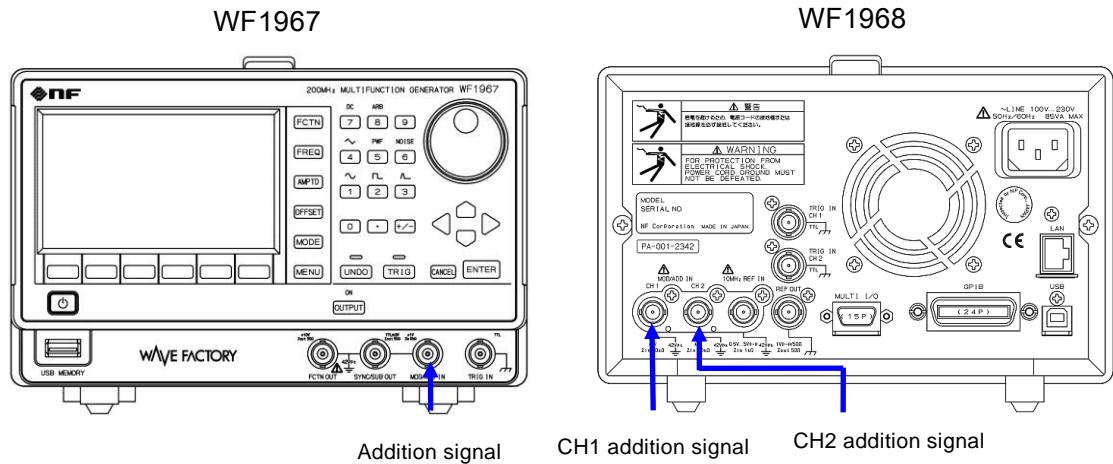

For the input characteristic, see P.3-10.

This BNC terminal is insulated from the chassis, and the same ground electrical potential as the waveform output of the identical channel. For the floating ground connection, see P.3-18

#### b) To activate an addition signal

Ext Add is set in the Utility.

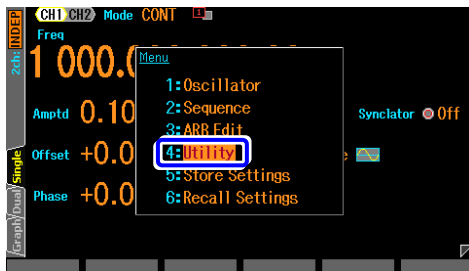

1. When the MENU key is pressed, the top menu opens. Then, press the soft-key corresponding to [UTILITY]. This opens the Utility.



2. On the Utility screen, select the [Ext Add] field and then press the Enter key.

On the Utility screen, select [Ext Add] and then press the ENTER key



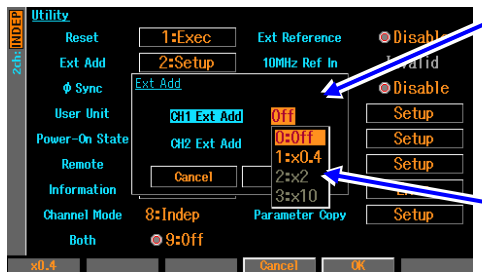

External addition setting window is opened

3. When the external addition settings window opens, select the desired output setting and press the ENTER key. When the selection list opens, select the desired setting and then press the ENTER key. [x0.4][x2][x10] represents the addition gain.

Set the external addition setting.



4. When the external addition setting is completed, select [OK], and then press the ENTER key. The change in the external addition setting is applied. When you do not want to apply the change, select [Cancel] and press the ENTER key, or press the CANCEL key.

Select [OK] and then press the ENTER key.

**c) If the desired external addition condition cannot be selected**

- External addition cannot be ON (set as x0.4, x2, x10)

An external modulation is used.

To use the external addition, change the modulation source to Internal.

The external addition input terminal is sharing with the external modulation input terminal.

Therefore, when External is specified as a modulation source for modulated oscillation except FSK and PSK, the external addition cannot be used. The external addition setting at this time is always becomes [Off].

Similarly, when an external addition is used, the external modulation cannot be used (excluding FSK and PSK).

- External addition gain cannot be set as the desired value

The gain of the external addition is decided by the output voltage range.

To set the external addition gain by a factor of 0.4, set the amplitude and the DC offset setting so that the output voltage range is 0.8V.

To set the external addition gain by a factor of 2, set the amplitude and the DC offset setting so that the output voltage range is 4V.

To set the external addition gain by a factor of 10, set the amplitude and the DC offset setting so that the output voltage range is 20V.

Because the external addition adds to the final stage of a waveform output (P.1-4), the addition gain is related to the output voltage range. It is fixed to x10 when the maximum output voltage of the range is 20V, fixed to x2 for 4V, fixed to x0.4 for 0.8V, and other addition gains cannot be selected.

Oppositely, when the external addition is used, the maximum output voltage of the range is fixed by the addition gain. Especially, note that the fineness of the amplitude precision and the waveform might decrease when the amplitude is reduced because it is fixed to 20V range when the addition gain is x10.

### 4.4.15 To Set Duty of Square Wave

The waveform is assumed to be set as square wave [Square]. For how to set the waveform, see P.4-15. The setting unit for duty is % only, and it is not possible to set or display with time.

#### a) How to set the duty

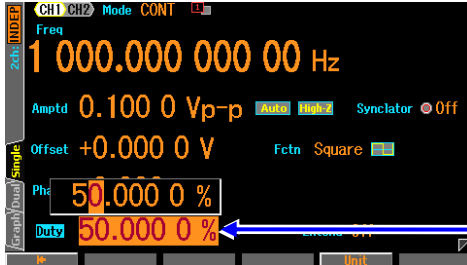

Duty  
Input  
Field

1. When the [Duty] field is selected and the ENTER key is pressed, the duty input field opens. [Duty] is displayed on the first page.

2. Select the digit to be changed by using the right or left arrow key, and then use the up or down arrow key or the modify knob to increment the value. The change is immediately reflected to the output. Or use the numeric keypad to enter the value. Press the ENTER key or the unit key (soft-key) [%] to set the input value and reflect it to the output. Even if the ENTER key is used, the output is set with %.

#### b) How to switch duty variable range

Normally, it should be used with Off (standard range).



Selection list (soft-key)

1. When the [Extend] field is selected and the ENTER key is pressed, the selection list for duty variable range enhancement On/Off opens. [Extend] is displayed on the first page.

2. Set and reflected in the output, when the desired condition is selected, and the corresponding soft-key is pressed.

## c) Difference between standard and enhanced duty variable range

Variable range	Features
Standard	Setting range: 0.0100% to 99.9900% <ul style="list-style-type: none"> <li>• Duty can be changed within the range where jitter is low and the pulse does not disappear.</li> <li>• The setting range of the duty narrows as the frequency rises.</li> <li>• The duty is fixed at 50% at 70MHz.</li> </ul>
Enhanced	Setting range: 0.0000% to 100.0000% (independent of frequency) <ul style="list-style-type: none"> <li>• There is jitter of 700ps rms or lower typ., and the duty can be always changed from 0% to 100%.</li> <li>• The pulse might sometimes disappear when the pulse width of the high level or the low level is narrower than that of 2.4ns. However, it becomes equal to the specified duty on average.</li> <li>• When 0% is set, the waveform is fixed to the low level, and when 100% is set, the waveform is fixed to the high level. The pulse is not output in either case.</li> <li>• When the oscillation frequency is an integer ratio compared to 420MHz, the edge time will become indeterminate by approximately 2.3ns. Under other conditions, it will be the specified duty "on average".</li> </ul>

## d) Restriction of duty and frequency when duty variable range is standard

The setting range of the duty is limited by the frequency within the following ranges:

$$\text{Frequency (Hz)/1 400 000} \leq \text{Duty (\%)} \leq 100 - \text{Frequency (Hz)/1 400 000}$$

For example, the variable range at 14MHz is limited to the range from 10% to 90%.

If the above-mentioned restriction is not filled by setting the frequency, the duty is adjusted.

✔ Check

When the duty variable range is enhanced, the frequency might become lower than the setting, because the pulse may disappear depending on the setting. Do not use it for the usage in which the frequency should be kept constant.

#### 4.4.16 To Set Pulse Width and Rising/Falling Time of Pulse Wave

The waveform is assumed to be set as pulse wave [Pulse]. For how to set the waveform, see P.4-15.

The pulse width can be set with either time or duty.

The rising time and the falling time can be set with time only.

##### a) How To Set Pulse Width time

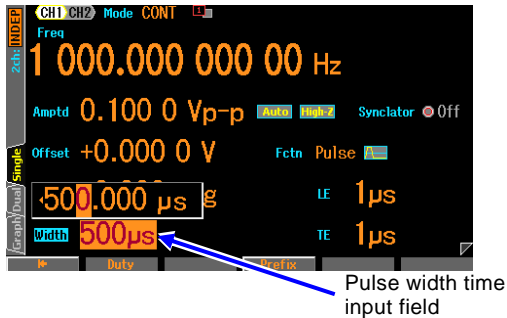

1. When the [Width] field is selected and the ENTER key is pressed, the input field for pulse width opens. [Width] is displayed on the first page. If [Duty] is displayed in the [Width] field, press the soft-key [Width] while the input field of the duty is open. It is switched to the pulse width time display.

2. Select the digit to be changed by using the right or left arrow key, and then use the up or down arrow key or the modify knob to increment the value. The change is immediately reflected to the output. Or use the numeric keypad to enter the value. Press the ENTER key or the unit key (soft-key) to set the input value and reflect it to the output. When the ENTER key is pressed, "s" is set as the unit.

##### b) How to set pulse width duty

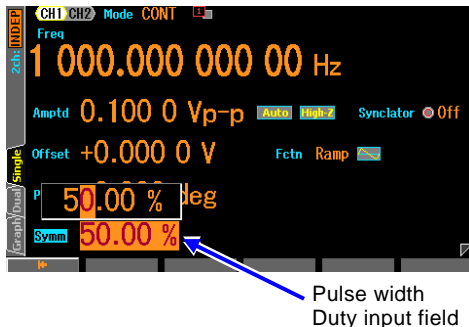

1. When the [Duty] field is selected and the ENTER key is pressed, the input field of pulse width duty opens. [Duty] is displayed on the first page. If [Width] is displayed in the [Duty] field, press the soft-key [Duty] while the duty input field is open. It is switched to the pulse width duty display.

2. Select the digit to be changed by using the right or left arrow key, and then use the up or down arrow key or the modify knob to increment the value. The change is immediately reflected to the output. Or use the numeric keypad to enter the value. Press the ENTER key or the unit key (soft-key) to set the input value and reflect it to the output. When the ENTER key is pressed, % is set as the unit.

### c) To toggle pulse width time and pulse width duty

- Pulse width time → Pulse width duty

The input field of pulse width time opens. When the current pulse width time is displayed, the soft-key [Duty] is displayed. Press the key opens the input field of Pulse width duty, and the display changes from [Width] to [Duty]. The soft-key [Duty] changes to [Width].

- Pulse width duty → Pulse width time

The input field of pulse width duty opens. When the current pulse width duty is displayed, the soft-key [Width] is displayed. Press the key opens the input field of Pulse width time, and the display changes from [Duty] to [Width]. The soft-key [Width] changes to [Duty].

### d) Difference between pulse width time setting and duty setting

The following different actions occur, depending on whether to set the pulse width with time or duty.

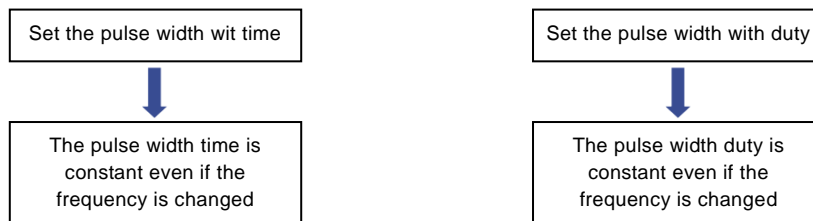

### e) How to set leading/falling time

The leading time [LE] and the trailing time [TE] can be set with time only.

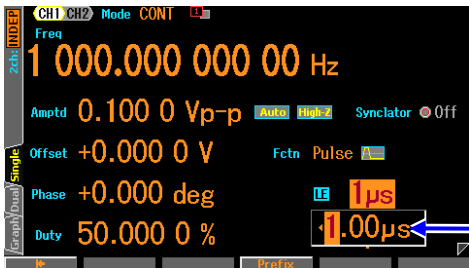

1. To set the leading time, select the [LE] field, and then press the ENTER key. The input field of leading time opens. To set the trailing time, select the [TE] field, and then press the ENTER key. The input field of trailing time opens. [LE][TE] is displayed on the first page.

2. Select the digit to be changed by using the right or left arrow key, and then use the up or down arrow key or the modify knob to increment the value. The change is immediately reflected to the output. Or use the numeric keypad to enter the value. Press the ENTER key or the unit key (soft-key) to set the input value and reflect it to the output. When the ENTER key is pressed, s is set as the unit.

### f) Definition and restriction of pulse width, leading time and trailing time

The definitions of pulse width, leading time and trailing time are shown in the following figure.

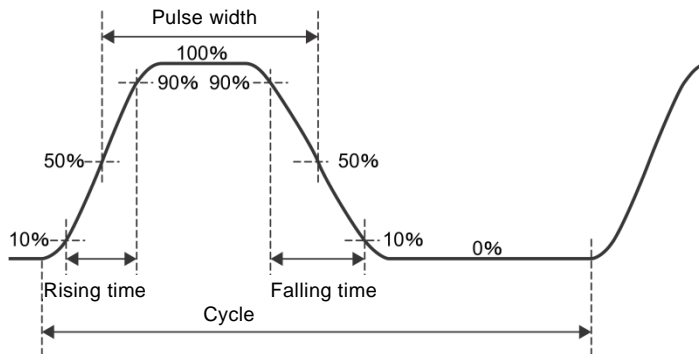

However, the setting range is restricted mutually as for pulse width, leading time, trailing time, and frequency as shown below.

If the following restriction is not filled by setting the frequency or the pulse width, the leading and trailing times are first adjusted, and then the pulse width is adjusted.

#### ■ Limitations on leading /trailing time

The leading time, trailing time and the frequency or the period are limited within the following ranges.

The larger of 1ppm of period or 4.21ns  $\leq$  Leading time

The larger of 1ppm of period or 4.21ns  $\leq$  Trailing time

For example, the leading time and the trailing time are limited to 10ns or longer at 100Hz.

Furthermore, the actual leading /trailing times which are output in the 20Vp-p range will be a maximum of 0.4ns later compared to other ranges even if the settings are the same.

#### ■ Restriction of pulse width, leading time and trailing time

The pulse width time, leading time, trailing time and the frequency or the period are limited as follow. When the pulse width is set with duty, the value converted into time shall be the pulse width time.

$$\left[ \begin{array}{l} \text{Leading time} + \\ \text{Trailing time} \end{array} \right] \times k \leq \text{Pulse width time} \leq \text{Period} - \left[ \begin{array}{l} \text{Leading time} + \\ \text{Trailing time} \end{array} \right] \times k$$

However,  $k = \frac{\pi}{4 \arcsin(0.8)} \doteq 0.847$

For example, if the leading time and trailing time are set to every 100ns at 1kHz, the pulse width time can vary between a range of 169.3ns to 999.83 $\mu$ s.

### 4.4.17 To Set Ramp Wave Symmetry

The waveform is assumed to be set to ramp wave [Ramp]. For how to set the waveform, see P.4-15. The setting unit for symmetry is % only, and it is not possible to set or display in units of time.

#### a) How to Set Symmetry

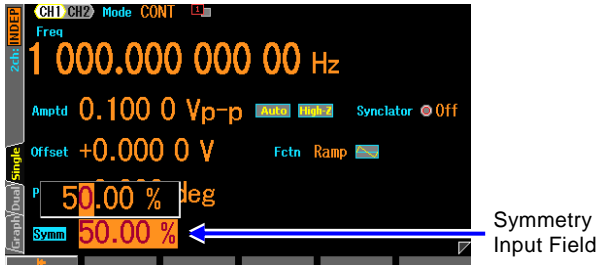

1. When the [Symm] field is selected and the ENTER key is pressed, the input field for pulse width time opens. [Symm] is displayed on the first page.

2. Select the digit to be changed by using the right or left arrow key, and then use the up or down arrow key or the modify knob to increment the value. The change is immediately reflected to the output. Or use the numeric keypad to enter the value. Press the ENTER key or the unit key (soft-key) to set the input value and reflect it to the output. When the ENTER key is pressed, % is set as the unit.

#### b) Relationship Between Symmetry and Waveform

Depending on the symmetry setting, a waveform changes as follows. The symmetry is the total ratio of the rising portion from start to finish. The point at which the phase is zero degrees has been fixed to zero of the amplitude except in the case where the symmetry is 0%.

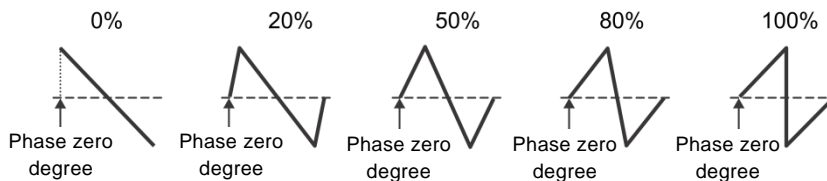

### 4.4.18 To Set the Equivalent Noise Bandwidth

When the noise waveform is selected, the [BW] item will appear to set the equivalent noise bandwidth. The equivalent noise bandwidth can be set to seven different levels.

The noise density will go down when the equivalent bandwidth is wide, even at the same output amplitude settings. Therefore, when wideband noise passes through a narrowband system the amplitude will keep getting smaller. Please choose the appropriate bandwidth setting.

### 4.4.19 To Select Sub Output

Choose the signal output from the synchronization/sub output BNC terminal with the [SubOut] setting on the second page of the Oscillator setting screen.

Although the selection list will change for the oscillation and other modes, the following selections are available for the continuous oscillation mode.

- Waveform Reference Phase Synchronization [Sync]

Outputs the main signal's waveform reference phase synchronization signal (50% duty square wave which rises at the main signal's 0° point).

■ **Sub Waveform [SubFctn]**

Outputs the sub waveforms common to the only frequency of main signal.

■ **Output Disabled [Off]**

Output is fixed at a low level. This helps to reduce interference from the synchronization signal.

**4.4.20 To Use Sub Waveforms**

If you use the sub waveform, it is available as a two-phase oscillator in WF1967, or a maximum four phase oscillator in WF1968.

**a) When Sub Waveforms is available**

Sub waveforms can be used when following Condition 1. Sub waveforms are output from the synchronization/sub output BNC terminal. It also shows the settings to use the modulation waveform as a sub-waveform in condition 2. This setting is characterized by can be set to a frequency different from the main waveform. However, only when this is not necessary to output a modulated wave to the main waveform for use.

■ **Condition 1 : Conditions that can be selected [SubFctn]**

Settings			limitations
Oscillation mode	Modulation	Source	
CONT	-	-	Sub frequency is same as main-output.
MODU	Off	-	Sub frequency is same as main-output.
	On	Ext	
BURST	Off	-	Sub-output is also burst. Sub frequency is same as main-output.
	On	Ext	

■ **Condition 2 : Conditions for use [ModFctn]**

Settings				description
Oscillation mode	Modulation	Source	Deviation	
MODU	-	Int	0	It is possible to different frequency from the main-output.
BURST	On	Int	0	Sub-output is continuous oscillation mode. It is possible to different frequency from the main-output.

**b) To Set Sub Waveforms**

Select the sub waveform [SubFctn] on the second page or modulation function [ModFctn] on the third page of the Oscillator setting screen.

Select from the following seven options:

- Sine wave [Sine]
- Square wave (duty 50%) [Square]
- Triangle wave (symmetry 50%) [Triangle]
- Down ramp wave[DnRamp]
- Noise[Noise]
- Arbitrary wave[ARB]



- Up ramp wave [UpRamp]

A selection button will appear when choosing an arbitrary waveform. This button will open a screen to select a arbitrary waveform.

A selection item for the bandwidth will also appear when selecting noise.

**c) To Set the Sub Waveform Frequency**

When the condition 1 of the above it will be forced to the same frequency as the main waveform.

When the condition 2, Select the modulation frequency [ModFreq] on the second page or third page of the Oscillator setting screen. ☞ P.4-58

**d) To Set the Sub Waveform Phase**

Select the sub waveform phase [SubPhs] on the second page or third page of the Oscillator setting screen.

**e) To Set the Sub Waveform Amplitude**

Select the sub waveform amplitude [SubAmp] on the second page or third page of the Oscillator setting screen.

The maximum total value of AC amplitude and DC offset is restricted to  $\pm 3V/\text{open}$ .

For example, when the AC amplitude is  $1V_{p-p}/\text{open}$ , DC offset is restricted to the range from  $-2.5V/\text{open}$  to  $+2.5V/\text{open}$ .

**f) To Set the Sub Waveform DC Offset**

Select the sub waveform offset [SubOfs] on the second page or third page of the Oscillator setting screen.

The setting range will be restricted along with the amplitude. Please see the previous section.

✓ Check

The following constraints will apply to the sub waveform settings when the main signal waveform is set to noise or DC, because the frequency is not defined.

1. The phase of the sub waveform cannot be set.
2. The amplitude of the sub waveform will be set to zero and cannot be changed, except when the sub waveform is set to noise.

## 4.5 Using Variable Parameter Waveforms

### a) Outputting Variable Parameter Waveforms(PWF)



Press the FCTN key to display the waveforms above the numeric keypad and select the key ([5] key) corresponding to the PWF. The waveform which is currently set as the PWF is output. Similar to other waveforms, the waveform's polarity and amplitude range may also be changed.

### b) To Change the Waveform of Variable Parameter Waveforms

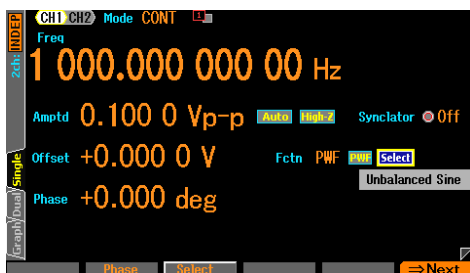

1. A [Select] button is displayed to the right of the polarity/amplitude range icon when the waveform is set to variable parameter waveform [PWF]. Pressing this button displays the name of the currently selected PWF. Press the ENTER key to display the PWF's selection screen.

2. Enter the variable parameter waveform and individual parameter settings on the variable parameter waveform selection screen.

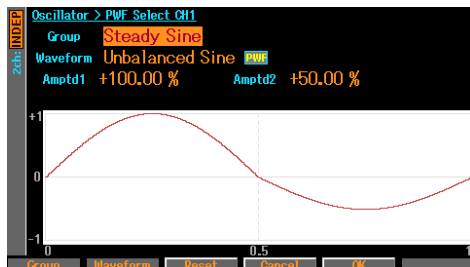

The PWF are categorized into groups due to their large number.

Set the group in the [Group] field.

Next, set the desired waveform from the group's waveforms in the [Waveform] field.

Set the polarity and amplitude range with the polarity/amplitude range icon. The settings are independent for each waveform. These settings

can be changed even if you leave the selection screen.

Each waveform has a maximum of 5 specific variable parameters to be set.

Press the [Reset] soft-key to initialize the variable parameters.

The change is immediately reflected to the output waveform. The shape of the set waveform is displayed on the graph.

For details on the variable parameters, [P. 6-2](#)

3. Press [OK] to enter the change and leave the selection screen.  
Press [Cancel] to discard the change and leave the selection screen.  
Press the basic parameter shortcut key to enter the change and leave the selection screen.

#### ✓ Check

The AC portion of the waveform may disappear depending on the settings.

Press the [Reset] soft-key if it is unclear how to restore the settings. This returns each parameter to the default factory settings. Polarity and amplitude range are not changed.

## 4.6 Using Arbitrary Waveforms

### a) Outputting Arbitrary Waveforms(ARB)



Press the [8] key on the numeric keypad to output an arbitrary waveform (ARB).

Press the FCTN key to display the waveforms above the numeric keypad and select the key ([8] key) corresponding to the ARB.

The waveform which is currently set as the arbitrary waveform is output. Similar to other waveforms, the waveform's polarity and amplitude range may also be changed.

### b) To Change the Waveform of Arbitrary Waveforms

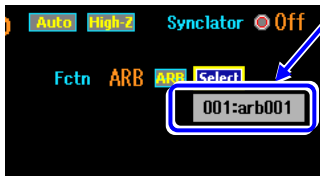

When [>] is selected, the selected arbitrary waveform is displayed directly beneath the field

1. [Select] will appear to the immediate right of [ARB] when setting the waveform to arbitrary waveform [ARB]. Use the arrow keys or modify knob to select this and display the currently selected arbitrary waveform as shown in the figure to the left. Press the [ENTER] key to move to the ARB selection screen.

2. Arbitrary waveform selection and name change can be done on the arbitrary waveform selection screen. Set the number of the waveform in the [ARB No.] field. The outline of the selected waveform can be checked with the graph display. For reading method of arbitrary waveform. P.7-9.

No.	Name	Type	Size[KiB]
0	<Edit Memory>	Point	2
1	arb001	Point	2
2	<Empty>	---	0
3	<Empty>	---	0
4	<Empty>	---	0
5	<Empty>	---	0
6	<Empty>	---	0
7	<Empty>	---	0
8	<Empty>	---	0
9	<Empty>	---	0

Total Size[KiB] 2/8192

The changes will not be reflected in the output until the [OK] soft-key is pressed. Arbitrary waveforms cannot be created on this screen. For creation of arbitrary waveforms, data format and memory capacity, P. 7-2. The method for changing the name is the same as for the settings memory. A maximum of 20 characters may be entered.

3. Press [OK] to enter the change and leave the selection screen. Press [Cancel] to discard the change and leave the selection screen. Press the basic parameter shortcut key to discard the change and leave the selection screen.

## 4.7 Setting and Operation of Modulation

### 4.7.1 Modulation Types

The following 8 types of modulations are available.

- FM: Frequency Modulation ☞ P.4-61
  
- FSK: Frequency Shift Keying  
Binary Frequency Shift Keying. ☞ P.4-62
  
- PM: Phase Modulation ☞ P.4-63
  
- PSK: Phase Shift Keying  
Binary Phase Shift Keying. ☞ P.4-64
  
- AM: Amplitude Modulation ☞ P.4-66
  
- AM (DSB-SC): Amplitude Modulation (Double Side Band - Suppressed Carrier)  
AM without the carrier frequency element. ☞ P.4-68
  
- DC offset modulation Offset Modulation ☞ P.4-69
  
- PWM: Pulse Width Modulation ☞ P.4-70

### 4.7.2 Screen for Setting and Operation of Modulation

The following explains the common screen configuration of the modulated oscillation mode and modulation function (in other modes).

Settings and operations are performed in the Oscillator setting screen. When you press the MENU key while another screen is displayed, the Top menu is displayed. Select [Oscillator] and then press the ENTER key.

#### a) To set the oscillation mode to modulation



Set the oscillation mode to [Modulation]

Press the MODE key to open the oscillation mode selection list. Please select the modulated oscillation mode [Modulation]. (P. 4-27)

This switches to modulated oscillation mode. There are total 2 pages of the setting screens in the modulated oscillation mode. You can switch the page by using the NEXT key.

Some of the modulation features may also be used with the sweep oscillation mode and the burst oscillation mode.

#### b) First page of the setting screen: screen for setting the carrier signal

Common items which are independent of the oscillation mode. This is the screen for setting the modulation carrier signal.

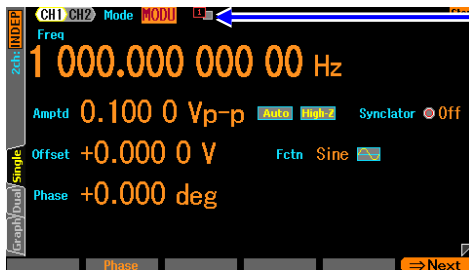

Indicates that the first page is displayed

Pressing the NEXT key switches the display to the second page

#### c) Second page of the setting screen: screen for setting the modulation function and synchronization/sub output terminal

This appears on page three in the burst oscillation mode and the sweep oscillation mode.

The following figure is an example of selecting FM as a modulation type.

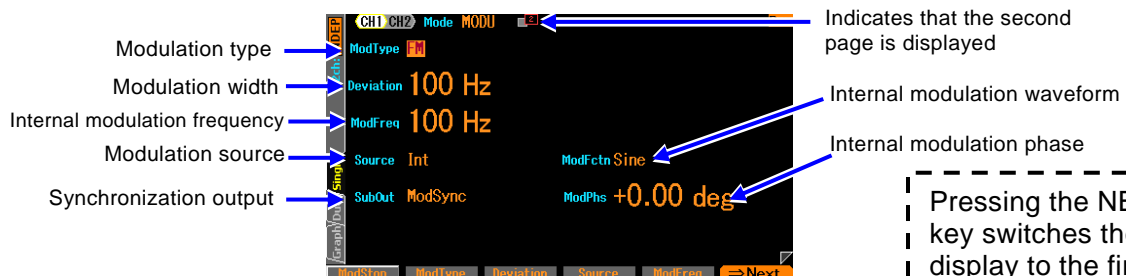

Indicates that the second page is displayed

Internal modulation waveform

Internal modulation phase

Pressing the NEXT key switches the display to the first page

○ Modulation type [ModType]

Select from FM, FSK, PM, PSK, AM, AM (DSB-SC), DC offset modulation, and PWM. ☞ P.4-58

Off (modulation function not used) is also available as a selection in sweep oscillation mode and burst oscillation mode. FSK and PSK cannot be selected in sweep oscillation mode and burst oscillation mode except when using auto burst.

○ Synclator synchronization source [SyncSrc]

This only appears when the Synclator function is turned on. This oscillation frequency synchronizes with the synchronization source specified here. The selection list is as follows:

☞ P.4-32

Channel 1	Channel 2 (WF1968 only)
CH1 trigger input terminal [Ext]	CH2 trigger input terminal [Ext]
-	CH1 trigger input terminal [Ch1]

The polarity can also be selected.

○ Modulation width [Deviation, Depth, HopFreq]

The item name changes with the modulation type. ☞ P.4-58

The modulation signal will have no effect on the main signal when the modulation width is set to 0. Selecting internal for the modulation source and internal modulation waveform [ModFctn] in the sub output selection [SubOut] will output an internal modulation signal from the synchronization/sub output BNC terminal. At this time, the internal modulation signal can be used as an independent signal source by setting the waveform, frequency, phase, and amplitude/DC offset.

○ Modulation source [Source]

Select internal [Int] or external [Ext] for the modulation source. ☞ P.4-58

Additionally, [Ch1] may be selected on channel 2 as same signal of channel 1. (WF1968 only) [Ch1] can only be selected when the modulation mode is FSK or PSK and the channel 1 modulation source is set to [Int].

Internal cannot be selected in sweep oscillation mode.

○ Internal modulation frequency [ModFreq]

This is the frequency of the internal modulation source. ☞ P.4-58

This item is not available when the modulation function is off or set to external modulation.

○ Internal modulation waveform [ModFctn]/Sub waveform [SubFctn]

Sets the waveform for the internal modulation source when the modulation function is turned on and set to internal modulation. Select from the sine wave, square wave, triangle wave, rising ramp wave, falling ramp wave, noise, and arbitrary wave. ☞ P.4-58

Selects the sub waveform sent to the sub output when the modulation function is turned off or not set to internal modulation.

○ Internal modulation phase [ModPhs] /Sub waveform phase [SubPhs]

This is the phase of the internal modulation source when the modulation function is turned on and set to internal modulation. Changes the phase difference between the reference phase of the internal modulation source and the waveform output.

Sets the sub waveform phase sent to the sub output when the modulation function is turned off or set to external modulation.

☞ P.4-58

○ Sub output selection [SubOut]

Selects the output signal from the synchronization/sub output terminal. Choose from the selection list. ☞ P.4-59

○ Sub output amplitude [SubAmp]

Sets the output amplitude when the internal modulation waveform and sub waveform are selected as the output signal from the synchronization/sub output terminal. ☞ P.4-51

○ Sub output offset [SubOfs]

Sets the output offset when the internal modulation waveform and sub waveform are selected as the output signal from the synchronization/sub output terminal. ☞ P.4-51

### 4.7.3 Common Settings and Operation of Modulation

The following explains the common settings and operation independent of the modulation type.

#### a) To set the oscillation mode modulation

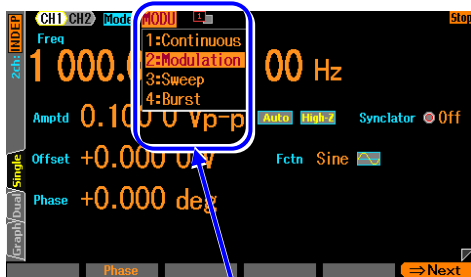

Changes the oscillation mode to [Modulation]

Press the MODE key to open the oscillation mode selection list. Please select the modulated oscillation mode [Modulation]. (P. 4-27)

This switches to modulated oscillation mode. There are 2 pages of the setting screens in the modulated oscillation mode. You can switch the page by using the NEXT key.

#### b) To select the type of modulation

Select from the following eight types in the modulation types [ModType] on the second page of the setting screen.



Modulation type

- FM[FM] P. 4-61
- FSK[FSK] P. 4-62
- PM[PM] P. 4-63
- PSK[PSK] P. 4-64
- AM[AM] P. 4-66
- AM(DSB-SC)[AM(SC)] P. 4-68
- DC offset modulation [OFSM] P. 4-69
- PWM[PWM] P. 4-70

#### c) To set the carrier condition

Set each parameter of the carrier signals on the first page of the setting screen.

#### d) To set the modulation width

Set in the modulation width on the second page of the setting screen. The name of displayed item differs among [Deviation], [Depth], and [HopFreq] depending on the modulation type. For details, see the description of each modulation type.

#### e) To modulate with internal signal source

Set the modulation source [Source] as internal [Int] on the second page of the setting screen. It is necessary to set the internal modulation waveform [ModFctn], the internal modulation frequency [ModFreq], and the internal modulation phase [ModPhs].

Select the internal modulation waveform [ModFctn] from the following seven types:

- Sine wave [Sine]
- Square wave (duty 50%) [Square]
- Triangle wave (symmetry 50%) [Triangle]
- Up ramp wave [UpRamp]
- Down ramp wave [DnRamp]
- Noise [Noise]
- Arbitrary wave [ARB]

If the internal modulation waveform is noise, the internal modulation frequency cannot be set. When the modulation type is FSK or PSK, the internal modulation waveform is fixed to the square wave with duty 50%.

Arbitrary waveforms in an array format use converted data comprising a total of 8192 points when an arbitrary waveform is selected as the internal modulation waveform. The arbitrary



waveforms where [RAW] is displayed in the [Type] field of the selection screen of arbitrary waveforms are in array format. On the other hand, arbitrary waveform where [Point] is displayed in the [Type] field are in control point format. In arbitrary waveforms in this format, the entire waveform is developed with 8192 points so that the features of the waveform may remain as much as possible. For the details of the arbitrary waveform, [☞ P.7-2](#).

Internal modulation phase [ModPhs] means that in a 2 channel unit the modulation source of channel 1 is set to internal and channel 2 is set to [Ch1]. Phase may be set independently for channels 1 and 2. Also, it changes to sub waveform phase [SubPhs] when the modulation function is off or set to external modulation. This allows the phase of the sub waveform to be set independently of the main output.

#### **f) To modulate with external signal source**

Set the modulation source [Source] as external [Ext] on the second page of the setting screen. The input terminal of the external modulation signal is different according to the modulation type as follows:

- Modulation type is FM, PM, AM, AM(SC), OSFM, PWM

Enter a modulation signal to the external modulation/addition input terminal. The setting of the modulation width is the value for a signal level of  $\pm 1V$ . Note that if the input level is lower than  $\pm 1V$ , the modulation width is lower than the specified value.

When the external modulation/addition input terminal is used for the external addition input, the external modulation function cannot be used.

- Modulation type is FSK or PSK

Enter a modulating signal (TTL level) to the external triggering input terminal.

The polarity can be set on the screen.

#### **g) To start modulation**

The modulated oscillation starts automatically when entering into the modulated oscillation mode.

However, the modulated oscillation will not start if the modulation setting is incorrect ([Conflict] will be displayed in the channel status area). When pressing the soft-key [?] displayed on the left end, the message concerning an improper setting appears. When that is changed to a proper setting, modulated oscillation starts. [☞ P.14-7](#)

When the modulation is temporarily stopped, press the soft-key [ModStart] to restart the modulation.

#### **h) To stop modulation**

When the soft-key [ModStop] is pressed under modulation, carrier signals are not modulated. The oscillation mode remains in modulated oscillation mode.

#### **i) To select the signal output from the synchronization/sub-output BNC terminal**

Set the sub output selection [SubOut] on the second page of the setting screen. Selection options change in the oscillation and other modes. Select from the following options.

Modulation function on and internal modulation	Modulation function off or external modulation
Waveform reference phase synchronization[Sync]	Waveform reference phase synchronization[Sync]
Internal modulation synchronization [ModSync]	-
Internal modulation waveform [ModFctn] *1	Sub waveform [SubFctn]
Output disabled [Off]	Output disabled [Off]

\*1: Cannot be selected in FSK or PSK.

■ When [Sync] is selected,

Signals with TTL level that are rising at the reference phase of waveform are output from the synchronization/sub-output terminal.

■ When [ModSync] is selected,

Signals with TTL level that synchronize with the internal modulation waveform are output from the synchronization/sub-output terminal. A square wave with duty 50% rising at the zero phase of the internal modulation waveform. When the internal modulation waveform is a noise, it is fixed to the low level.

When a signal under modulation is observed with the oscilloscope etc., it can be used as a trigger signal of the oscilloscope.

■ When [ModFctn] is selected,(only when modulation function is on and using internal modulation)

The internal modulation waveform is output from the synchronization/sub-output BNC terminal. The amplitude can be set in the sub output amplitude [SubAmp] and the DC offset in sub output offset [SubOfs] with a maximum signal level of  $\pm 3V$ /open.

When the modulation width is 0 the modulation waveform has no effect on the main output. This allows the sub output to be used as an independent signal source with its own frequency setting. This means that the WF1967 can be used as an output oscillator with 2 independent channels and the WF1968 as a 4 channel independent output oscillator.

■ When [SubFctn] is selected,(only when using external modulation)

Outputs a sub waveform from the synchronization/sub output BNC terminal. The frequency is same as main output. The waveform, amplitude, offset and phase are settable independent from main output. See P.4-50.

■ When [Off] is selected.

The output will be low level. This helps to reduce interference from the synchronization output signal.

■ When [BrstSync] [SwpSync] [SwpSync+Mkr] [X-Drive] are selected

Refer to the explanations of burst oscillation mode (P.4-88) and sweep oscillation mode (P.4-71).

#### 4.7.4 Setting FM

The output frequency changes according to the instantaneous value of modulation signal.

For the modulation setting screen and the common operation method, please refer to P.4-55, P.4-58

##### a) Example of FM

When the modulating signal swings to a positive side, the frequency shift of the output signal increases. (Frequency will increase)

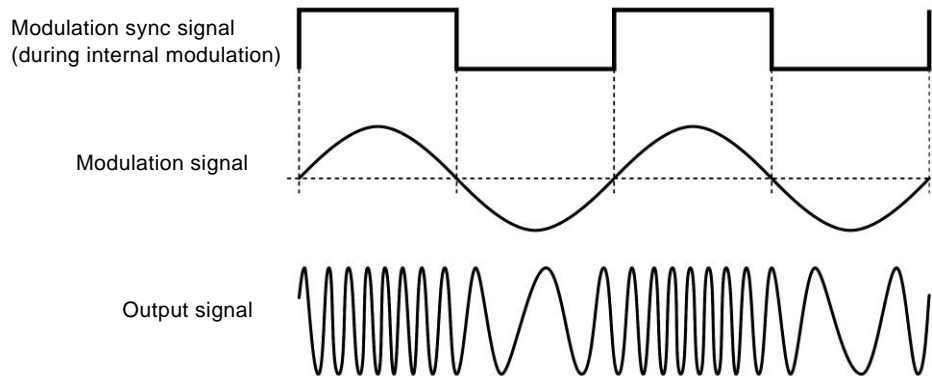

##### b) To select FM

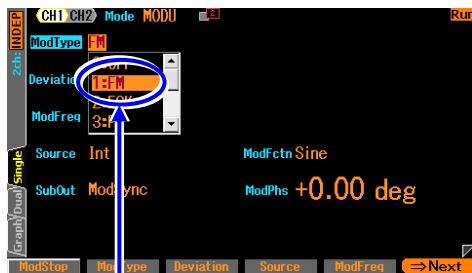

Select [FM] in the modulation type setting menu

Set the modulation type [ModType] to FM [FM] on the second page of the setting screen when the oscillation mode [Mode] is set to modulation [Modulation] and on the third page of the setting screen when the mode is burst [BURST] or sweep [SWEEP].

##### c) Waveform or mode where FM is unavailable

Noise, pulse, and DC cannot perform FM. FM cannot be used with frequency sweep.

Setting FM will force quit the Synclator function.

##### d) Setting items necessary for FM

Set the carrier frequency [Freq] on the first page of the setting screen.

Set the peak frequency deviation [Deviation] on the second page of the setting screen.

The output frequency changes within the range of carrier frequency  $\pm$  peak frequency deviation.

When the modulation source [Source] is internal [Int], set the modulation waveform [ModFctn], modulation frequency [ModFreq], and modulation phase [ModPhs]. Internal [Int] cannot be selected during sweep oscillation mode.

When the modulation source [Source] is external [Ext], enter the modulating signal to the external modulation/addition input terminal. It reaches the specified peak frequency deviation at  $\pm 1V$  input.

### 4.7.5 Setting FSK

A binary frequency deviation modulation that output frequency is switched between the carrier frequency and the hop frequency according to the modulating signal.

For the modulation setting screen and the common operation method, please refer to P.4-55, P.4-58

#### a) Example of FSK

The phase continuity of output signals is maintained though the frequency changes abruptly.

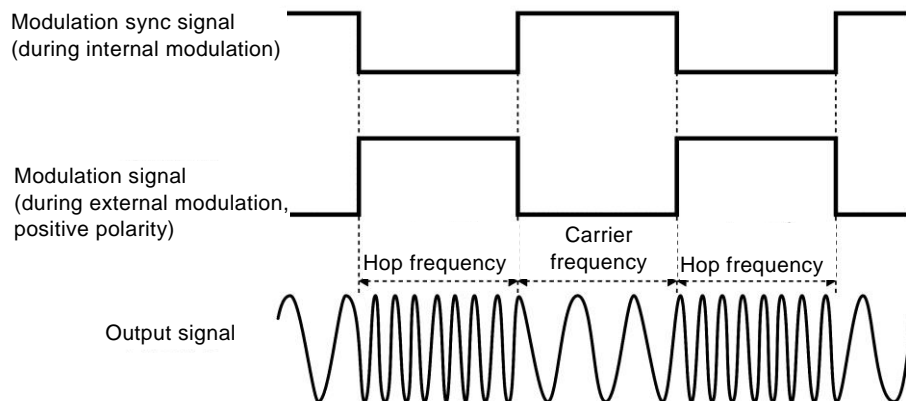

#### b) To select FSK



Select [FSK] in the modulation type setting menu

Set the modulation type [ModType] to FSK [FSK] on the second page of the setting screen when the oscillation mode [Mode] is set to modulation [MODU] and on the third page of the setting screen when the mode is sweep [SWEEP].

#### c) Waveform or mode where FSK is unavailable

Noise, pulse, and DC cannot perform FSK.

FSK cannot be used in sweep oscillation mode and burst oscillation mode except auto burst.

Setting FSK will force quit the Synclator function.

#### d) Setting items necessary for FSK

Set the carrier frequency [Freq] on the first page of the setting screen.

Set the hop frequency [HopFreq] on the second page of the setting screen.

The carrier frequency and the hop frequency appear alternately in the output frequency.

When the modulation source [Source] is internal [Int], set the modulation waveform [ModFctn] and modulation phase [ModPhs]. Internal [Int] cannot be selected during sweep oscillation mode.

Set the polarity of the trigger when the modulation source [Source] is external [Ext], and then enter the modulation signal (TTL level) to the external trigger input terminal. When the polarity is set as positive [High], the carrier frequency is output for low-level input, and the hop

frequency is output for high-level input. When the polarity is set as negative [Low], that is reversed.

#### 4.7.6 Setting PM

The output phase changes according to the instantaneous value of modulation signal.

For the modulation setting screen and the common operation method, please refer to P.4-55, P.4-58

##### a) Example of PM

When the modulating signal swings to a positive side, the phase shift of the output signal increases.

The instantaneous frequency also changes at the same time because the phase changes with time.

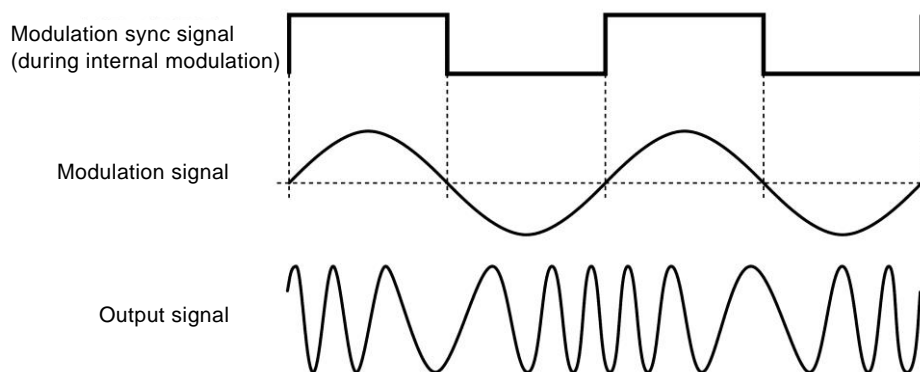

##### b) To select PM



Select [PM] in the modulation type setting menu

Set the modulation type [ModType] to PM [PM] on the second page of the setting screen when the oscillation mode [Mode] is set to modulation [MODU] and on the third page of the setting screen when the mode is burst [BURST] or sweep [SWEEP].

##### c) Waveform or mode where PM is unavailable

Noise and DC cannot perform PM.

PM cannot be performed with phase sweep.

##### d) Setting items necessary for PM

Set the peak phase deviation [Deviation] on the second page of the setting screen.

The output phase changes within the range of  $\pm$  peak phase deviation.

When the modulation source [Source] is internal [Int], set the modulation waveform [ModFctn], modulation frequency [ModFreq], and modulation phase [ModPhs]. Internal [Int] cannot be selected during sweep oscillation mode.

When the modulation source [Source] is external [Ext], enter the modulating signal to the

external modulation/addition input terminal. It reaches the specified peak phase deviation at  $\pm 1V$  input.

### 4.7.7 Setting PSK

A binary frequency deviation modulation that the output phase offsets according to the modulation signal.

For the modulation setting screen and the common operation method, please refer to P.4-55, P.4-58

#### a) Example of PSK

Because the phase changes abruptly, the output signal waveform is discontinuous.

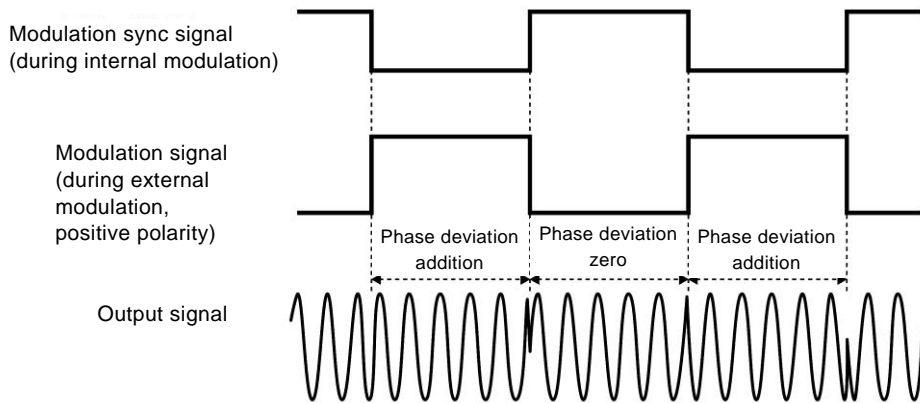

#### b) To select PSK



Select [PSK] in the modulation type setting menu

Set the modulation type [ModType] to PSK [PSK] on the second page of the setting screen when the oscillation mode [Mode] is set to modulation [MODU] and on the third page of the setting screen when the mode is sweep [SWEEP].

#### c) Waveform or mode where PSK is unavailable

Noise and DC cannot perform PSK.

PSK cannot be used in sweep oscillation mode and burst oscillation mode except auto burst.

Setting PSK will force quit the Synclator function.

#### d) Setting items necessary for PSK

Set the phase deviation [Deviation] on the second page of the setting screen.

The state of phase deviation zero and the state of a specified phase deviation appear alternately in the output.

Note that the phase does not change within the range of  $\pm$  phase deviation.

When the modulation source [Source] is internal [Int], set the modulation frequency [ModFreq]

and modulation phase [ModPhs]. Internal [Int] cannot be selected during sweep oscillation mode.

Set the polarity of the trigger when the modulation source [Source] is external [Ext], and then enter the modulation signal (TTL level) to the external trigger input terminal. When the polarity is set as positive [High], the phase deviation of zero is output for low-level input, and the specified phase deviation is output for high-level input. When the polarity is set as negative [Low], that is reversed.

### 4.7.8 Setting AM

The output amplitude changes according to the instantaneous value of modulation signal.

For the modulation setting screen and the common operation method, please refer to P.4-55, P.4-58

#### a) Example of AM

When the modulating signal swings to a positive side, the amplitude of the output signal increases.

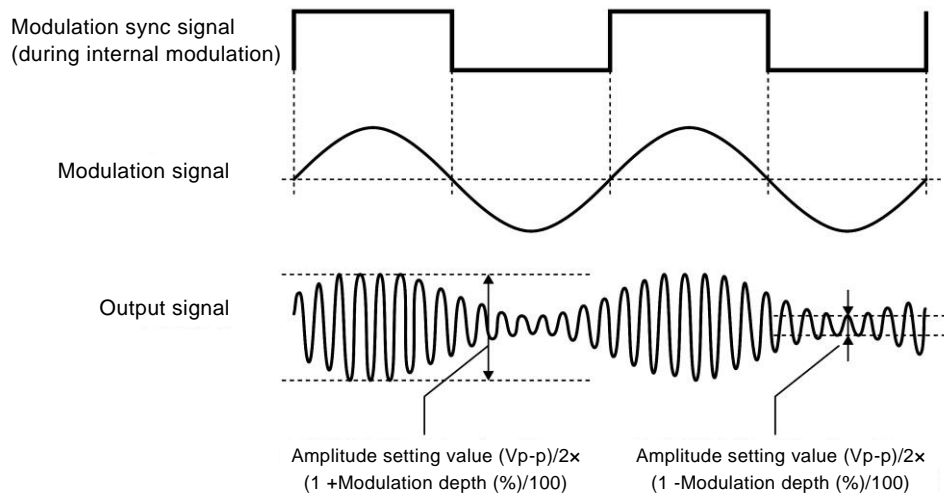

#### b) To select AM

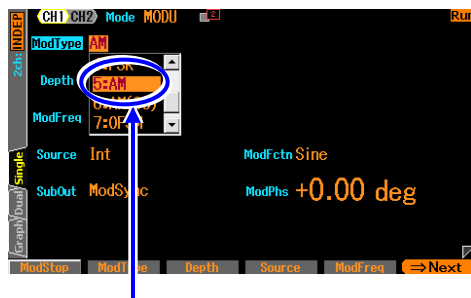

Select [AM] in the modulation type setting menu

Set the modulation type [ModType] to AM [AM] on the second page of the setting screen when the oscillation mode [Mode] is set to modulation [Modulation] and on the third page of the setting screen when the mode is burst [BURST] or sweep [SWEEP].

#### c) Waveform where AM is unavailable

AM cannot be performed with DC.

Amplitude sweep cannot be performed with AM.

#### d) Setting items necessary for AM

Set the carrier amplitude [Amplitude] on the first page of the setting screen.

Set the modulation depth [Depth] on the second page of the setting screen.

The output amplitude changes within the range of the carrier amplitude setting value  $(V_{p-p}) / 2 \times (1 \pm \text{modulation depth } (\%) / 100)$ .

When the modulation depth is 0% or the modulation is stopped, the output amplitude is half of that in the continuous oscillation mode.

When the modulation depth is 100%, the maximum value of the output amplitude envelope is equal to the carrier amplitude setting value.



When the modulation source [Source] is internal [Int], set the modulation waveform [ModFctn], modulation frequency [ModFreq], and modulation phase [ModPhs]. Internal [Int] cannot be selected during sweep oscillation mode.

When the modulation source [Source] is external [Ext], enter the modulating signal to the external modulation/addition input terminal.

It is at the specified modulation depth when  $\pm 1\text{V}$  is entered.

### 4.7.9 Setting AM (DSB-SC)

The output amplitude changes according to the instantaneous value of modulation signal. AM without carrier frequency element.

DSB-SC is abbreviation of Double Side Band - Suppressed Carrier.

For the modulation setting screen and the common operation method, please refer to P.4-55, P.4-58

#### a) AM (DSB-SC) example

The amplitude of output signal increases when the absolute value of the amplitude of modulation signal is large. The polarity of the output signal reverses when the modulation signal is negative.

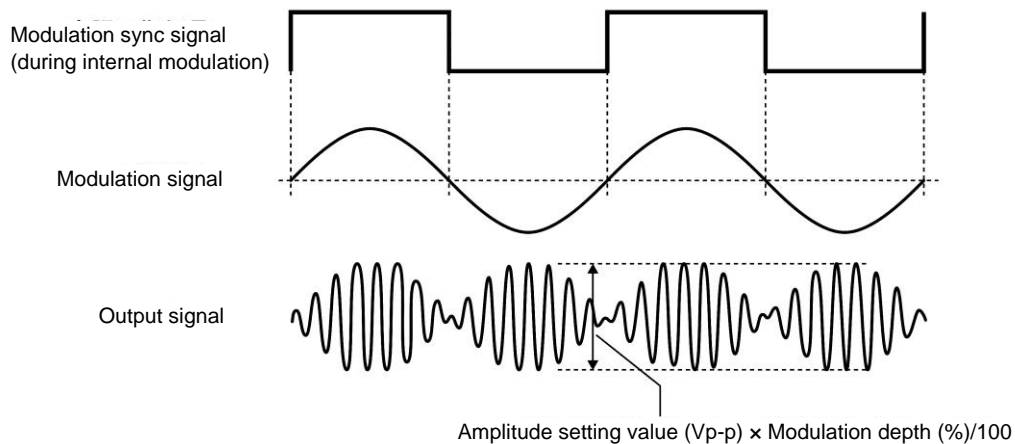

#### b) To select AM (DSB-SC)

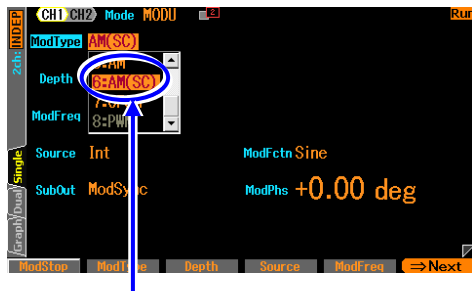

Select [AM(SC)] in the modulation type setting menu

Set the modulation type [ModType] to AM(DSB-SC) [AM(SC)] on the second page of the setting screen when the oscillation mode [Mode] is set to modulation [MODU] and on the third page of the setting screen when the mode is burst [BURST] or sweep [SWEEP].

#### c) Waveform where AM (DSB-SC) is unavailable

AM (DSB-SC) cannot be performed with DC.

Amplitude sweep cannot be performed with AM (DSB-SC).

#### d) Setting items necessary for AM (DSB-SC)

Set the carrier amplitude [Amplitude] on the first page of the setting screen.

Set the modulation depth [Depth] on the second page of the setting screen.

The output amplitude changes within the range of the carrier amplitude setting value (Vp-p) x modulation depth (%) / 100.

When the modulation depth is 100%, the maximum value of the output amplitude envelope is equal to the carrier amplitude setting value.

When the modulation source [Source] is internal [Int], set the modulation waveform [ModFctn], modulation frequency [ModFreq], and modulation phase [ModPhs]. Internal [Int] cannot be selected during sweep oscillation mode.

When the modulation source [Source] is external [Ext], enter the modulating signal to the external modulation/addition input terminal. It is at the specified modulation depth when  $\pm 1V$  is entered.

### 4.7.10 Setting DC Offset Modulation

The DC offset changes according to the instantaneous value of modulation signal.

For the modulation setting screen and the common operation method, please refer to P.4-55, P.4-58

#### a) DC offset modulation example

When the modulating signal swings to the positive side, the DC offset of the output signal increases in the positive direction.

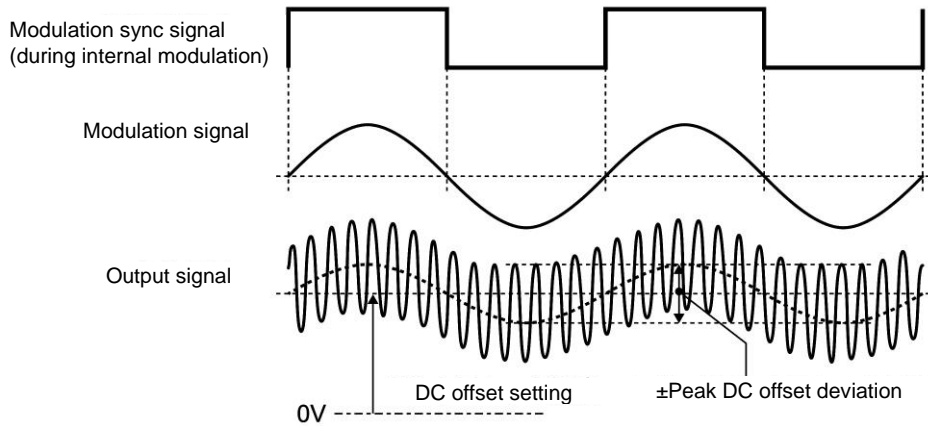

#### b) To select DC offset modulation

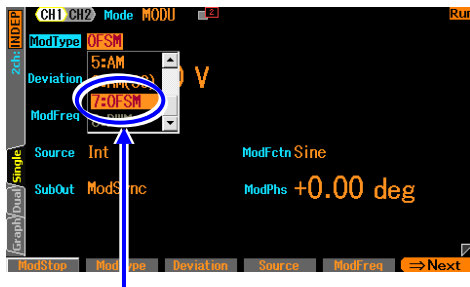

Select [OFSM] in the modulation type setting menu

Set the modulation type [ModType] to DC offset modulation [OFSM] on the second page of the setting screen when the oscillation mode [Mode] is set to modulation [MODU] and on the third page of the setting screen when the mode is burst [BURST] or sweep [SWEEP].

#### c) Waveform or mode where DC offset modulation is unavailable

There are no waveforms where DC offset modulation is unavailable. All waveforms are included. DC offset modulation cannot be performed with DC offset sweep.

#### d) Setting items necessary for dc offset modulation

Set the DC offset [Offset] on the first page of the setting page.

Set the peak DC offset deviation [Deviation] on the second page of the setting page.

The output DC offset changes within the range of DC offset setting  $\pm$  peak DC offset deviation. When the modulation source [Source] is internal [Int], set the modulation waveform [ModFctn], modulation frequency [ModFreq], and modulation phase [ModPhs]. Internal [Int] cannot be selected during sweep oscillation mode.

When the modulation source [Source] is external [Ext], enter the modulating signal to the external modulation/addition input terminal. It reaches the specified peak DC offset deviation at  $\pm 1V$  input.

### 4.7.11 Setting PWM

The duty of the square wave and the pulse wave is changed depending on instantaneous value of the modulation signal.

For the modulation setting screen and the common operation method, please refer to P.4-55, P.4-58

#### a) Example of PWM

When the modulating signal swings to a positive side, the duty of the output signal increases.

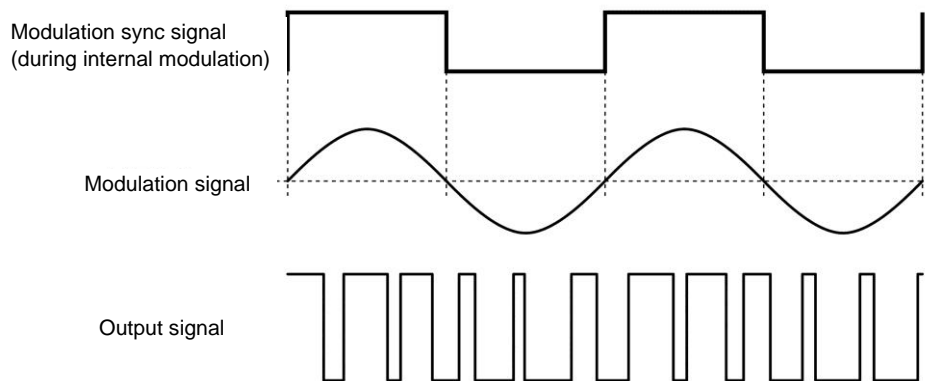

#### b) To select PWM

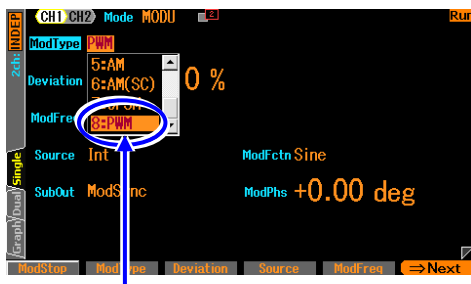

Select [PWM] in the modulation type setting menu

Set the modulation type [ModType] to PWM [PWM] on the second page of the setting screen when the oscillation mode [Mode] is set to modulation [MODU] and on the third page of the setting screen when the mode is burst [BURST] or sweep [SWEEP].

#### c) Waveform or mode where PWM is unavailable

PWM can be processed only to the square wave and the pulse wave.

PWM is not available for other waveforms.

Duty sweep cannot be performed with PWM.

#### d) Setting items necessary for PWM

Set the carrier duty [Duty] on the first page of the setting screen.

Set the peak duty deviation [Deviation] on the second page of the setting page.

The output duty is changed within the range of carrier duty  $\pm$  peak duty deviation.

When the pulse-wave is used, the pulse width of the carrier is fixed to the duty setting and cannot be set with time.

When the modulation source [Source] is internal [Int], set the modulation waveform [ModFctn], modulation frequency [ModFreq], and modulation phase [ModPhs]. Internal [Int] cannot be selected during sweep oscillation mode.

When the modulation source [Source] is external [Ext], enter the modulating signal to the external modulation/addition input terminal. It reaches the specified peak duty deviation at  $\pm 1V$  input.

## 4.8 Setting and Operation of Sweep

### 4.8.1 Sweep type (Sweep type)

Sweep can be done for the following five types:

- Frequency sweep ☞ P.4-82
- Phase sweep ☞ P.4-83
- Amplitude sweep ☞ P.4-84
- DC offset sweep ☞ P.4-85
- Duty sweep ☞ P.4-86

### 4.8.2 Screen for Setting and Operation of Sweep

This section describes the common screen structure in the sweep oscillation mode.

Settings and operations are performed in the Oscillator setting screen. When you press the MENU key while another screen is displayed, the Top menu is displayed. Select [Oscillator] and then press the ENTER key.

#### a) To set the oscillation mode to sweep



Press the MODE key to open the oscillation mode selection list. Select the sweep oscillation mode [Sweep]. (☞ P.4-27)

This switches to the sweep oscillation mode.

There are 3 pages of setting screens in total in the modulated oscillation mode. You can switch the page by using the NEXT key.

Changes the oscillation mode to [Sweep]

Selecting sweep oscillation mode force quits the Synclator function.

#### b) First page of the setting screen: Basic parameter setting screen

These are common items which are independent of the oscillation mode. Some settings are invalid depending on the sweep type.

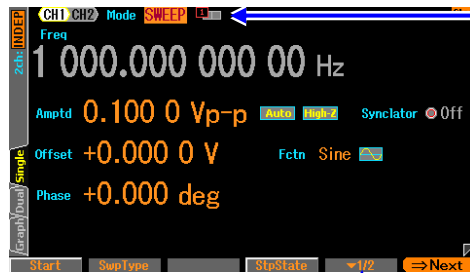

Indicates the first page is displayed

Pressing the NEXT key switches the display to the second page

There are two stages of soft-keys

### c) Second page of the setting screen: Screen for Setting the Sweep

The following figure is an example of selecting the frequency as a sweep type.

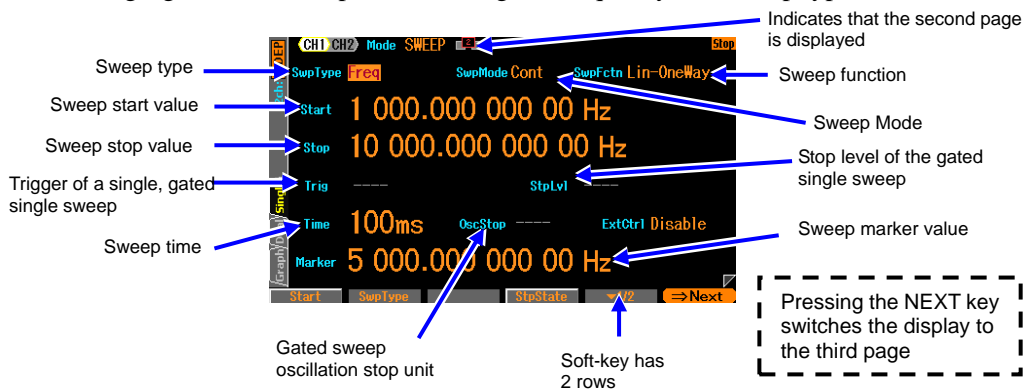

- Sweep type [SwpType]  
Subject to be swept. Select one from among frequency, phase, amplitude, DC offset, and duty. ☞ P.4-74
- Sweep Mode [SwpMode]  
The oscillation style of sweep. Select from continuous sweep, single sweep, and gate single sweep. ☞ P.4-75
- Sweep function [SwpFctn]  
Sweep form. Select from one-way, shuttle. Linear and log are available only when the sweep type is frequency. ☞ P.4-75
- Sweep start value [Start]  
The starting value of sweep. ☞ P.4-74
- Sweep stop value [Stop]  
The stop value of sweep. ☞ P.4-74
- Trigger [Trig]  
The trigger condition of single sweep and gated single sweep. Select as a trigger source from the inside or outside. ☞ P.4-77
- Stop level [StpLvl]  
The signal level when gated single sweep is stopped. Set the level by specifying Off or On. ☞ P.4-76
- Sweep time [Time]  
Transition time to sweep from the starting value to the stop value.
- The oscillation stop unit [OscStop] in the gated single sweep  
The oscillation stop unit in the gated single sweep. Select from 1 cycle unit and half cycle unit. ☞ P.4-76
- External control [ExtCtrl] via the Multi I/O connector  
External control by the Multi I/O connector is enabled, disabled. ☞ P.4-81
- Sweep marker value [Marker]  
The marker value of sweep. ☞ P.4-79

d) **Third page of the setting screen: screen for setting the modulation function and synchronization/sub output terminal**



○ Modulation type [ModType]

These are the types of modulation. Select from FM, PM, AM, AM (DSB-SC), DC offset modulation, PWM and Off. ☞ P.4-58

FSK, PSK and sweep target parameters cannot be selected in sweep oscillation mode.

○ Modulation width [Deviation, Depth, HopFreq]

This is the modulation width. The item name changes with the modulation type. ☞ P.4-58

○ Modulation source [Source]

The modulation source is fixed to external [Ext] in sweep oscillation mode. Internal [Int] cannot be selected.

○ Sub output selection [SubOut]

Selects the output signal from the synchronization/sub output terminal. Choose from the selection list. ☞ P.4-79

### 4.8.3 Common Setting and Operation of Sweep

This section describes the common settings and operations regardless of the items to sweep all together.

#### a) To sweep oscillation mode



Changes the oscillation mode to [Sweep]

Press the MODE key to open the oscillation mode selection list. Select the sweep oscillation mode [Sweep]. This switches to the sweep oscillation mode. There are 3 pages of setting screens in total in the modulated oscillation mode. You can switch the page by using the NEXT key.

#### b) To select sweep object

Select the object to sweep in the sweep types [SwpType] on the second page of the setting screen from the following five items.



- Frequency Sweep [Freq] ⌘ P.4-82
- Phase sweep [Phase] ⌘ P.4-83
- Amplitude sweep [Amptd] ⌘ P.4-84
- DC offset sweep [Offset] ⌘ P.4-85
- Duty sweep [Duty] ⌘ P.4-86

#### c) To set range and time to sweep

Set the following items on the second page of the setting screen.

- Starting value [Start]
  - Stop value [Stop]
  - Sweep time [Time]: Time to change from the starting value to the stop value.
- For details, see the description of each sweep type.

#### d) To set sweep range with center and span

When the input field of the start/stop value is opened and the current value is displayed on the second page of the setting screen, the soft-key [Center] or [Span] is displayed. When this key is pressed, the input field of the center/span value is opened, and the displayed items are changed from [Start], [Stop] to [Center], [Span] respectively.

The soft-key [Center], [Span] is also changed to [Start], [Stop]. When the soft-key [Start], [Stop] is pressed here, then the input field of the start/stop value is opened.

The center value is the average of the starting value and stop value. The span value is the absolute value of difference of the starting value and stop value. If the log sweep of the frequency is selected, the center value is an arithmetic average of the starting and the stop value.

If it is changed to the center value or span value, the magnitude relation of the starting value and the stop value is maintained.



**e) To sweep as sawtooth wave**

Set the sweep function [SwpFctn] on the second page of the setting screen as One-way [OneWay].

For frequency sweep, linear [Lin-OneWay] or log [Log-OneWay] is available for the slope.

One-way sweep

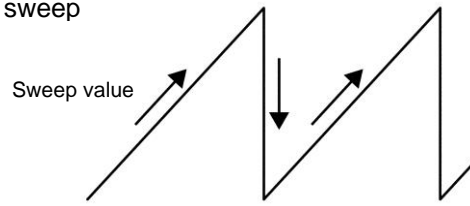

**f) To sweep as triangular waveform**

Set the sweep function [SwpFctn] on the second page of the setting screen as Shuttle [Shuttle].

For frequency sweep, linear [Lin-Shuttle] or log [Log-Shuttle] is available for the slope.

Shuttle sweep

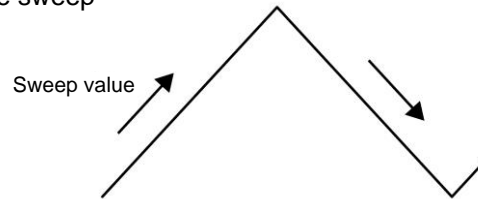

**g) To change upward/downward direction of sweep**

Sweep from the starting value toward the stop value for sweep with sawtooth waveform (one-way sweep). The value increases during sweep, when the starting value < stop value during sweep. Oppositely, the value decreases during sweep, when the starting value > stop value during sweep. When the soft-key [Stt⇌Stp] of the soft-key set (displayed as [▼ 2/2] on the right end soft-key) on the second row of the second page of the setting screen is pressed, the starting value and the stop value can be swapped.

**h) To repeat sweep continuously**

Set the sweep mode [SwpMode] on the second page of the setting screen as continuous [Cont].

A trigger signal is not necessary.

Set the change time from the starting value to the stop value with sweep time [Time] on the same 2nd page.

Because the sweep time is the change time from the starting value to the stop value, the repeating period is twice the sweep time setting as shown in following figure, when the sweep function is shuttle.

Continuous one-way sweep

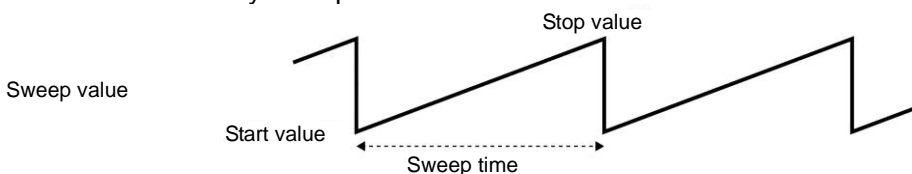

Frequency sweep example

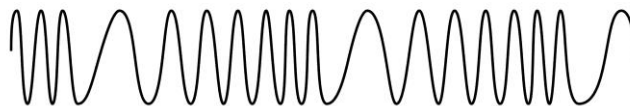

Continuous shuttle sweep

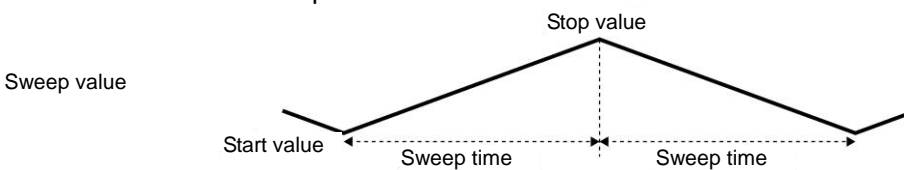

Frequency sweep example

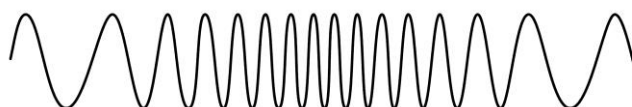

**i) To start sweep with trigger**

Set the sweep mode [SwpMode] on the second page of the setting screen as single [Single].

Because a trigger signal is necessary, set a trigger source in trigger [Trig] on the same 2nd page. For trigger setting, [P.4-77](#).

Set the change time from the starting value to the stop value with sweep time [Time] on the same 2nd page.

Sweep once in single sweep every time a trigger is accepted. If a trigger is received during a sweep, the sweep will restart from the start value.

The appearance of the change is different as shown in the following figure depending on whether it is one-way or shuttle sweep function.

In case of one-way sweep, it returns to the start value immediately after the sweep ends.

In case of shuttle sweep, it stands by in sweep terminated state after the sweep ends.

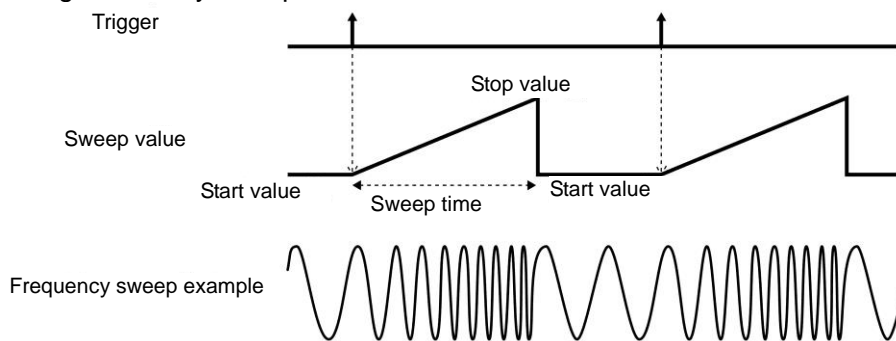
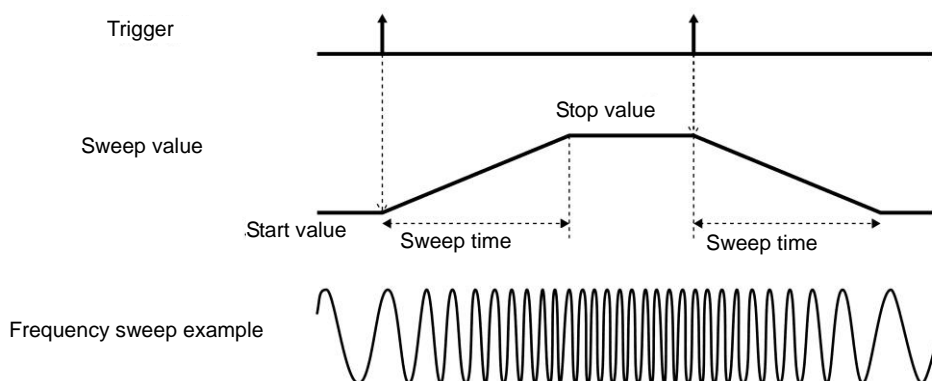
**Single one-way sweep****Single shuttle sweep****j) To output waveform only when sweep running**

Set the sweep mode [SwpMode] on the second page of the setting screen as gated single [Gated].

This is an operation that combines gate oscillation with sweep. Sweeps start with a trigger. Because a trigger signal is necessary, set a trigger source in trigger [Trig] on the same second page. For trigger setting, [P.4-77](#).

- **Start oscillation/stop phase**

Set start oscillation/stop phase in the phase [Phase] on the first page of the setting screen.

However, in phase sweep, the start phase setting is the oscillation starting phase, and the stop phase setting is the oscillation stop phase.

- **Stop level**

When you want to decide the level while oscillation is stopped apart from the phase, set the stop level [StpLvl] on the second page of the setting screen as On [On], and then set the level with % value based on the amplitude full scale. When [Off] is selected, the signal level while oscillation is stopped is decided by the phase set in [Phase] on the first page of the setting screen. For stop level, [P.4-97](#).

■ Oscillation stop unit (usually set as 1 cycle [Cycle])

When you want to stop the oscillation every half cycle, set the oscillation stop unit [OscStop] to half cycle [HalfCycle] on the second page of the setting screen. When it is set as 1 cycle [Cycle], it is oscillation with integer cycle.

Because it ends without fail by every one cycle or half cycle, the oscillation time is almost longer than the time set in the sweep time setting.

Gated single one-way sweep

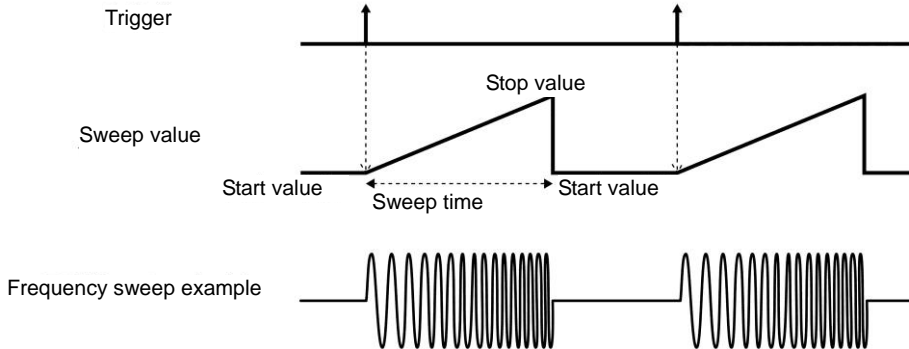

Gated single shuttle sweep

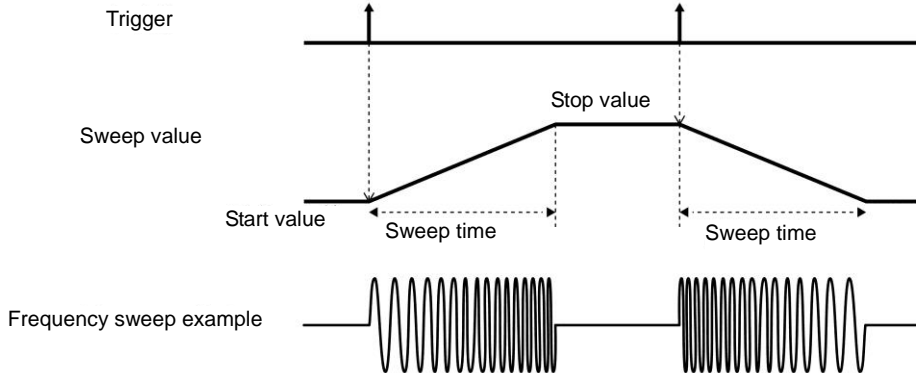

✓ Check

In phase sweep, the start phase setting is the oscillation starting phase, and the stop phase setting is the oscillation stop phase.

**k) To set trigger condition of single sweep and gated single sweep**

Internal trigger oscillator, external signal, manual trigger operation, and remote trigger can be used as a trigger.

When a trigger is received, the TRIG'D lamp up side of the TRIG key lights up.

A trigger condition is set in the trigger [Trig] on the second page of the setting screen.

■ Trigger source setting

A trigger source can be selected from internal [Int] or external [Ext].

When a trigger source is internal [Int], a trigger cycle can be set.

When a trigger source is external [Ext], the polarity of a trigger can be set.

When a trigger source is external [Ext], enter a trigger signal with a TTL level to the external trigger input terminal (TRIG IN).

Operations to start and stop a sweep can be performed independently of the trigger source setting with a logic signal input to the Multi I/O connector. ☞ P.4-81

■ How to use manual and remote triggers

Manual trigger operation and remote trigger operation is effective, regardless of the trigger source setting.

The soft-key [Start] and TRIG key can be used for manual trigger operation.

However, in the case of WF1968, the TRIG key only works on the channel side where the display is active. For the channel where the display is active, [☞ P.4-20](#)

When only manual trigger operation and remote trigger operation are used for a trigger, set the trigger source as external [Ext]. Moreover, we recommend that the polarity is set to [Off] to avoid malfunctions caused by exogenous noise.

#### **l) To start a sweep**

In continuous sweep, sweep oscillation mode starts automatically the sweep process. However, if the sweep setting is not appropriate, the sweep oscillation will not start ([CNFLC] (Conflict) is displayed in the channel status area). When pressing the soft-key [?] displayed on the left end, the message concerning an improper setting appears. When that is changed to a proper setting, sweep oscillation starts. [☞ P.14-8](#)

If sweep is stopped, press the soft-key [Start] to start the sweep. If the soft-key [Start] is not displayed, press the right end soft-key [▼2/2] to toggle the soft-key set.

In case of single sweep or gated single sweep, when a trigger is accepted, the sweep is started. However, if the sweep setting is not appropriate, trigger cannot be received ([CNFLC] (conflict) is displayed in the channel status area). When pressing the soft-key [?] displayed on the left end, the message concerning an improper setting appears. When it is changed to the correct setting, a trigger can be accepted. [☞ P. 14-8](#)

The soft-key [Start] and the manual trigger key on the panel operate as manual trigger operation, regardless of the trigger source setting.

#### **m) To pause sweep**

When the soft-key [Stop] is pressed while sweep is running, the sweep stops and enter the state to output a sweep starting value (not stop value). If the soft-key [Stop] is not displayed, press the right end soft-key [▼2/2] to toggle the soft-key set. However, in case of single sweep or gated single sweep, when a new trigger is accepted, the sweep is started again.

#### **n) To pause sweep temporarily**

When pushing [Hold] soft-key while a sweep is executed, the sweep is paused. Afterwards, when the soft-key [Resume] is pushed, the sweep is restarted at the point where it is paused. If the soft-key [Hold] or [Resume] is not displayed, press the right end soft-key [▼2/2] to toggle the soft-key set.

However, in case of single sweep or gated single sweep, when a new trigger is accepted during being held, the sweep is started from the beginning.

The soft-key [Hold] and [Resume] are displayed as [Hold] during sweep, and as [Resume] during pause, at the same position.

#### **o) To output sweep starting value**

When the soft-key [SttState] is pressed, it enters into the status to output the sweep starting value. You can check the status of tested equipment with sweep starting value.

The soft-key [SttState] is displayed in the status to output the sweep stop value. If the soft-key [SttState] is not displayed, press the right end soft-key [▼2/2] to toggle the soft-key set.

In case of gated single sweep, it is in oscillation status with starting value. To stop the oscillation, press the soft-key [Stop].

**p) To output sweep stop value**

When the soft-key [StpState] is pressed, it enters into the status to output the sweep stop value.

You can check the status of tested equipment with sweep stop value.

The soft-key [StpState] is displayed when the output is not at the sweep stop value. If the soft-key [StpState] is not displayed, press the right end soft-key [▼ 2/2] to toggle the soft-key set.

In case of gated single sweep, it is in oscillation status with stop value. To stop the oscillation, press the soft-key [Stop].

**q) To output a sweep synchronization signal, sweep marker signal, sweep x drive signal**

Set in the synchronization/sub output [SubOut] on the third page of the setting screen. Select from the following four options:

- Signal that synchronizes with reference phase of waveform [Sync]
- Signal that synchronizes with sweep [SwpSync]
- Signal that combining a marker signal and a signal that synchronizes with the sweep [SwpSync+Mkr]
- X drive signal of sweep [X-Drive]
- Output disabled [Off]

■ When [Sync] is selected

Signals with TTL level that are rising at the reference phase of waveform are output from the synchronization/sub-output terminal.

■ When [SwpSync] is selected

A TTL level signal that synchronizes with the sweep is output from the synchronization/sub-output terminal. It changes from high to low at the time of starting sweep.

■ When [SwpSync+Mkr] is selected

The rising of sweep synchronous output is a marker signal. The sweep synchronous output is low until it reaches the marker value from the sweep starting value. The sweep synchronization output does not change on the return path of a shuttle sweep.

Timing for the signal under sweep to pass the marker value can be known.

However, there are the following restrictions for time zone when a synchronous sweep output is low level.

- Time zone is limited from about 0.05% to 99.95% of the sweep time. Therefore, the time zone does not change even if the marker value is changed when the marker value is close to the starting value or the stop value.
- Resolution of time zone is limited to the larger value of either 1/32768 of the sweep time or 2.38ns. Therefore, the time zone does not necessarily change even if the marker value is changed finely.

■ When [X-Drive] is selected

A signal with the value of -3V to +3V/open corresponding to the sweep is output from the synchronization/sub-output terminal. The voltage changes linearly in proportion to sweep elapsed time. The voltage also changes linearly in proportion to sweep elapsed time, even if logarithmic sweep [Log-OneWay] and [Log-Shuttle] is selected as the sweep function in frequency sweep. When a signal during sweep is observed with oscilloscope with X-Y display or X-Y recorder, it can be used as a signal of the X axis.

The following figure shows the relation between a sweep value and each signal. When the stop value < the starting value, the slope of the sweep X drive output is contrary to the figure.

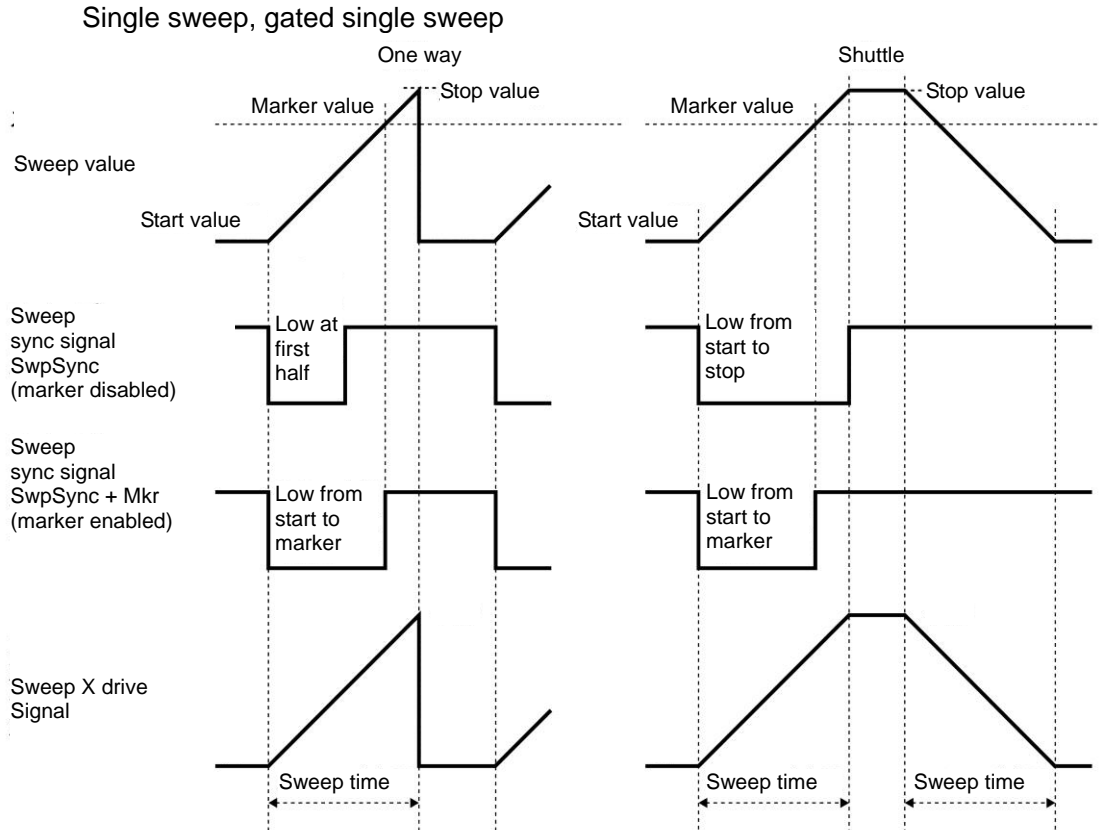

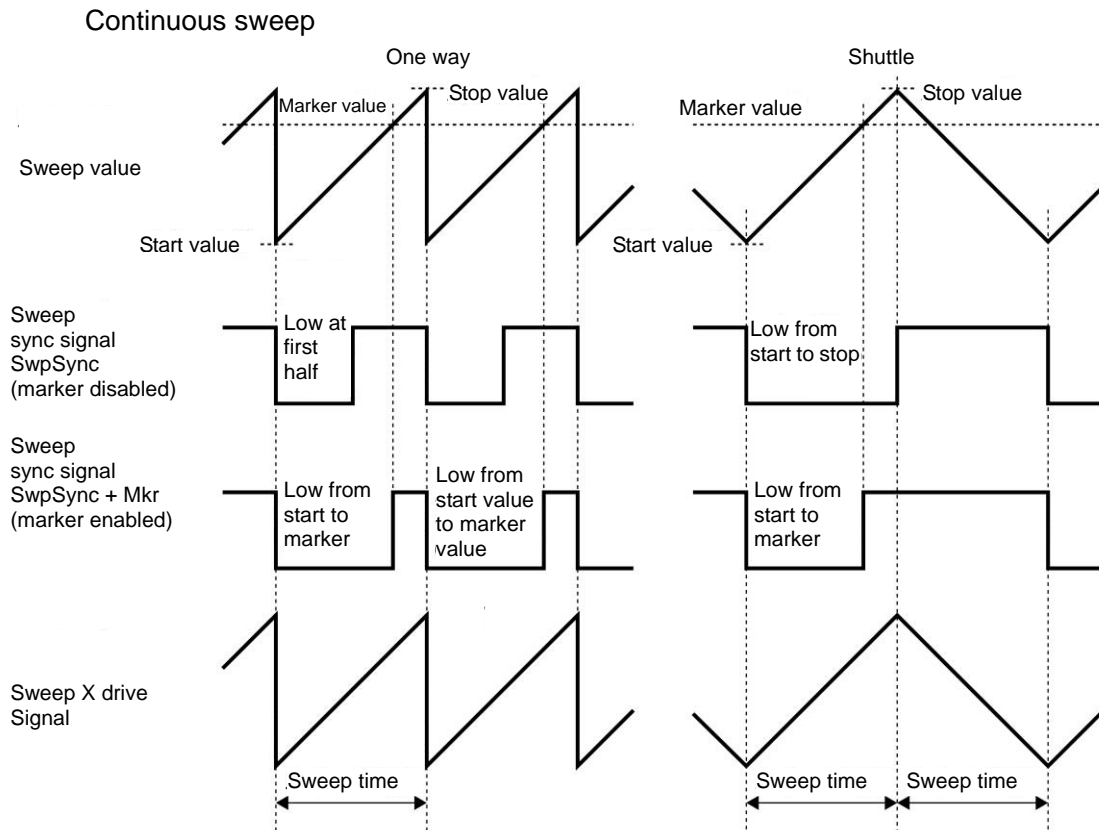

■ When [Off] is selected

The output will be low level. This helps to reduce interference from synchronization output signal.

r) **To assign a marker value for a center value, or to assign a center value for a marker value**

When the soft-key [Ctr⇒Mkr] is pressed on the second page, a center value is assigned for a marker value. When the soft-key [Mkr⇒Ctr] is pressed, the marker value is oppositely assigned for the center value. If these soft-keys on the second page of the setting screen are not displayed, press the right end soft-key [▼ 1/2] to toggle the soft-key set.

s) **To control the sweep start, stop and pause with an external logic signal**

Set the external control [ExtCtrl] to enable [Enable] on page two of the setting screen to conduct sweep operations with a TTL level logic input to the Multi I/O connector on the rear panel. This is shared by CH1 and CH2.

It is recommended that this be set to disable [Disable] when not using an external control signal in order to avoid malfunctions caused by exogenous noise. For pin number assignment, see P.3-16. The following operations can be performed.

■ Sweep start (pin 14)

Falling input to pin 14 starts the sweep. The sweep will restart from the beginning even if it is already running.

In the case of a single sweep or a gated single sweep, the sweep will start from the beginning when a trigger is received. The operation is a logical sum with the trigger source that is set.

■ Sweep stop (pin 13)

Falling input to pin 13 stops the sweep, and the output returns to the sweep start value.

However, in the case of a single sweep or a gated single sweep, the sweep will start from the beginning when a new trigger is received.

■ Sweep hold/resume (pin 12)

Falling input to pin 12 holds the sweep if it is running. If the sweep is temporarily stopped, it will restart from the hold position.

However, if a new trigger is received while a single sweep or gated single sweep is temporarily

stopped, the sweep (out-going or return for shuttle) will start from the beginning.

#### 4.8.4 Setting Frequency Sweep

For the sweep setting screen and the common operation method, please refer to P.4-71, P.4-74

##### a) Frequency sweep example

Examples of a continuous sweep and linear shuttle.

Shuttle sweep

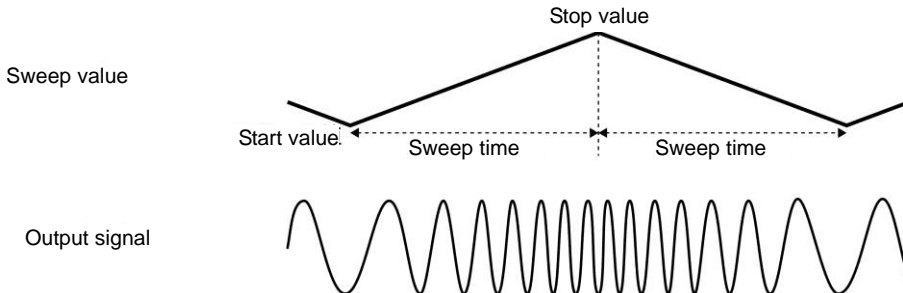

##### b) To select frequency sweep

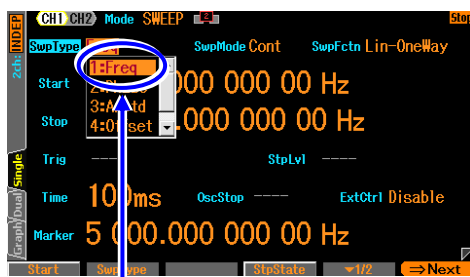

When the oscillation mode [Mode] is set to sweep oscillation mode [SWEEP], select the sweep type [SwpType] on the second page of the setting screen to display the selection list. Selecting frequency [Freq] sets the frequency sweep.

In the sweep type setting menu, Select [Freq].

##### c) Waveform or mode where frequency sweep is unavailable

Noise, pulse, and DC cannot perform frequency sweep.

FSK, FM and PSK modulation are canceled (modulation function turned off) when frequency sweep is selected.

##### d) Items necessary for frequency sweep

Set the following items on the second page of the setting screen. The frequency setting on page one of the setting screen becomes invalid and the current oscillation frequency is displayed.

- Starting frequency [Start]  
The frequency range depends on a waveform.
- Stop frequency [Stop]  
The frequency range depends on a waveform.
- Sweep time [Time]  
Time to change from the starting frequency to the stop frequency. ☞ P.4-74
- Sweep Mode [SwpMode]  
Select from continuous, single, or gated single. ☞ P.4-75
- Sweep function [SwpFctn]  
Select from one-way/shuttle or linear/log. ☞ P.4-75

It is possible to set with center frequency [Center], and span frequency [Span], instead of start frequency, and stop frequency. ☞ P.4-74

When sweep mode is single or gated single, it is necessary to set the trigger condition [Trig]. ☞ P.4-77

Set the following items as needed:



- Marker frequency [Marker] (second page of the setting screen) P.4-79
- Stop level [StpLvl] (second page of the setting screen) P.4-76  
The setting used for gated single sweep only.
- Oscillation stop unit of the gated single sweep [OscStop] (second page of the setting screen) P.4-76  
The setting used for gated single sweep only.
- Synchronization/sub output selection [SubOut] (third page of the setting screen) P.4-79

### 4.8.5 Setting Phase Sweep

For the sweep setting screen and the common operation method, please refer to P.4-71, P.4-74

#### a) Phase sweep example

Examples of a continuous sweep and linear shuttle.

Shuttle sweep

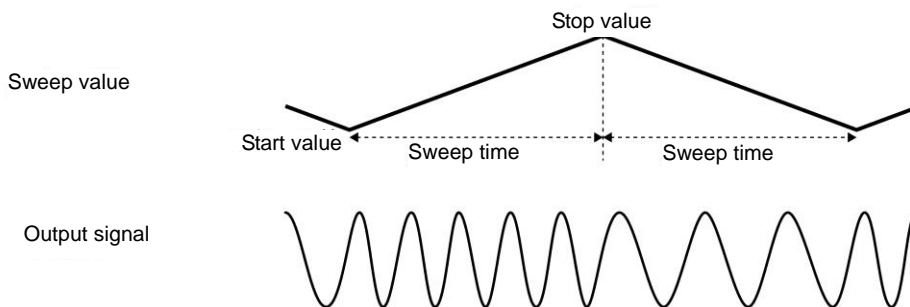

When the phase increases, the frequency rises as by the following value. When the phase decreases, the frequency falls by following value.

$$\frac{|\text{Stop phase (deg)} - \text{Start phase (deg)}|}{360} \times \frac{1}{\text{Sweep time(sec)}}$$

#### b) To select phase sweep



When the oscillation mode [Mode] is set to sweep oscillation mode [SWEEP], select the sweep type [SwpType] on the second page of the setting screen to display the selection list. Selecting phase [Phase] sets the phase sweep.

Select [Phase] in the sweep type setting menu

#### c) Waveform or mode where phase sweep is unavailable

Noise and DC cannot perform phase sweep.

FSK, PSK and PM modulation are canceled (modulation function turned off) when phase sweep is selected.

#### d) Items necessary for phase sweep

Set the following items on the second page of the setting screen. The phase setting on first page of the setting screen becomes invalid, and the current phase is displayed.

- Starting phase [Start]
- Stop phase [Stop]
- Sweep time [Time]  
Time to change from the starting phase to the stop phase. P.4-74
- Sweep Mode [SwpMode]

- Select from continuous, single, or gated single. [☞ P.4-75](#)
- Sweep function [SwpFctn]

Select from one-way, shuttle. [☞ P.4-75](#)

It is possible to set with center phase [Center], and span phase [Span], instead of start phase, and stop phase. [☞ P.4-74](#)

When sweep mode is single or gated single, it is necessary to set the trigger condition [Trig]. [☞ P.4-77](#)

Set the following items as needed:

- Marker phase [Marker] (second page of the setting screen) [☞ P.4-79](#)
- Stop level [StpLvl] (second page of the setting screen) [☞ P.4-76](#)  
The setting used for gated single sweep only.
- Oscillation stop unit of the gated single sweep [OscStop] (second page of the setting screen) [☞ P.4-76](#)  
The setting used for gated single sweep only.
- Synchronization/sub output selection [SubOut] (third page of the setting screen) [☞ P.4-79](#)

### 4.8.6 Setting Amplitude Sweep

For the sweep setting screen and the common operation method, please refer to P.4-71, P.4-74

#### a) Amplitude sweep example

Examples of a continuous sweep and linear shuttle.

Shuttle sweep

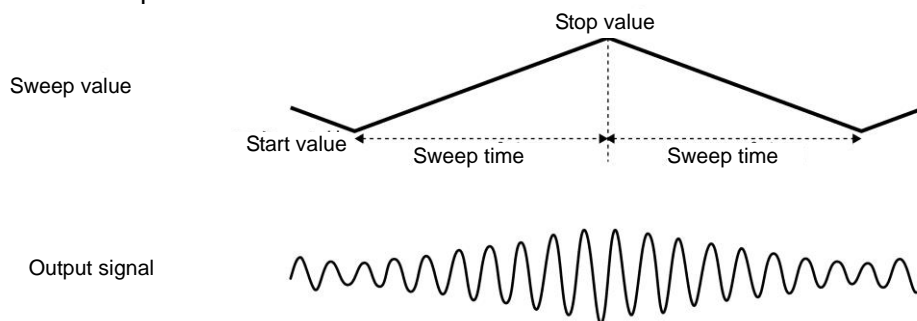

#### b) To select amplitude sweep

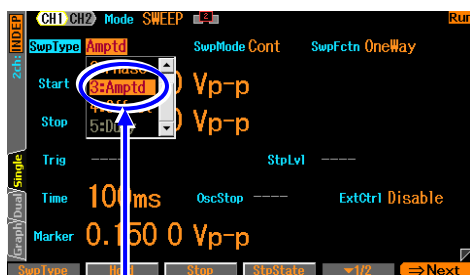

Select [Amptd] in the sweep type setting menu

When the oscillation mode [Mode] is set to sweep oscillation mode [SWEEP], select the sweep type [SwpType] on the second page of the setting screen to display the selection list. When amplitude [Amptd] is selected, amplitude sweep is set.

#### c) Waveform or mode where amplitude sweep is unavailable

Amplitude sweep cannot be performed with DC.

AM and AM (DSB-SC) modulation are canceled (modulation function turned off) when amplitude sweep is specified.

#### d) Items necessary for amplitude sweep

Set the following items on the second page of the setting screen. The amplitude setting on first page of the setting screen becomes invalid, and the current amplitude is displayed.

- Starting amplitude [Start]

- Stop amplitude [Stop]
- Sweep time [Time]  
Time to change from the starting amplitude to the stop amplitude. [☞ P.4-74](#)
- Sweep Mode [SwpMode]  
Select from continuous, single, or gated single. [☞ P.4-75](#)
- Sweep function [SwpFctn]  
Select from one-way, shuttle. [☞ P.4-75](#)

It is possible to set with center amplitude [Center], and span amplitude [Span], instead of start amplitude, and stop amplitude. [☞ P.4-74](#)

When sweep mode is single or gated single, it is necessary to set the trigger condition [Trig]. [☞ P.4-77](#)

Set the following items as needed:

- Marker amplitude [Marker] (second page of the setting screen) [☞ P.4-79](#)
- Stop level [StpLvl] (second page of the setting screen) [☞ P.4-76](#)  
The setting used for gated single sweep only.
- Oscillation stop unit of the gated single sweep [OscStop] (second page of the setting screen) [☞ P.4-76](#)  
The setting used for gated single sweep only.
- Synchronization/sub output selection [SubOut] (third page of the setting screen) [☞ P.4-79](#)

### 4.8.7 Setting DC Offset Sweep

For the sweep setting screen and the common operation method, please refer to P.4-71, P.4-74

#### a) DC offset sweep example

Examples of a continuous sweep and linear shuttle.

Shuttle sweep

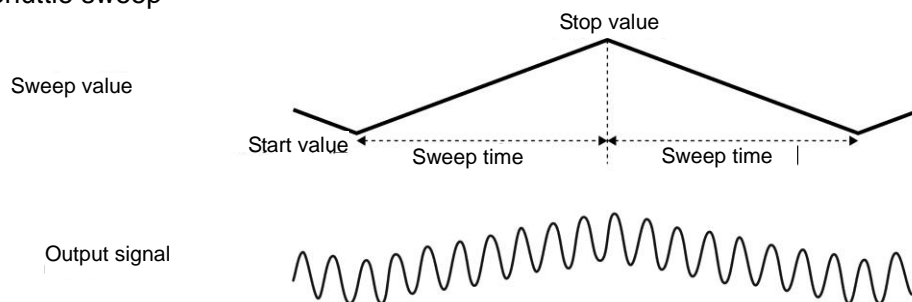

#### b) To select DC offset sweep

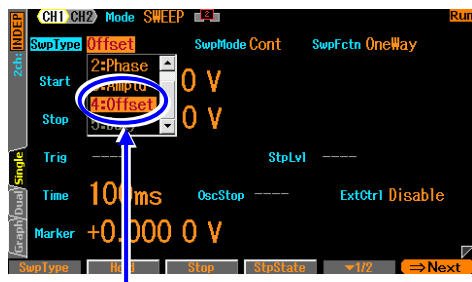

Select [Offset] in the sweep type setting menu

When the oscillation mode [Mode] is set to sweep oscillation mode [SWEEP], select the sweep type [SwpType] on the second page of the setting screen to display the selection list. When the DC offset [Offset] is pressed, DC offset sweep is set.

#### c) Waveform or mode where DC offset sweep is unavailable

None. However, when DC is selected as a waveform, the DC level itself is swept. In addition, when DC is selected as a waveform, gated single sweep cannot be performed.

DC offset modulation is canceled (modulation function turned off) when DC offset sweep is specified.

#### d) Items necessary for DC offset sweep

Set the following items on the second page of the setting screen. The DC offset setting on first page of the setting screen becomes invalid, and the current DC offset is displayed.

- Start DC offset [Start]
- Stop DC offset [Stop]
- Sweep time [Time]

Time to change from the starting DC offset to the stop DC offset.

☞ P.4-74

- Sweep Mode [SwpMode]

Select from continuous, single, or gated single. ☞ P.4-75

- Sweep function [SwpFctn]

Select from one-way, shuttle. ☞ P.4-75

It is possible to set with center DC offset [Center] / span DC offset [Span], instead of start DC offset / stop DC offset. ☞ P.4-74

When sweep mode is single or gated single, it is necessary to set the trigger condition [Trig]. ☞ P.4-77

Set the following items as needed:

- Marker DC offset [Marker] (second page of the setting screen) ☞ P.4-79
- Stop level [StpLvl] (second page of the setting screen) ☞ P.4-76  
The setting used for gated single sweep only.
- Oscillation stop unit of the gated single sweep [OscStop] (second page of the setting screen) ☞ P.4-76  
The setting used for gated single sweep only.
- Synchronization/sub output selection [SubOut] (third page of the setting screen) ☞ P.4-79

### 4.8.8 Setting Duty Sweep

For the sweep setting screen and the common operation method, please refer to P.4-71, P.4-74

#### a) Duty sweep example

Examples of a continuous sweep and linear shuttle.

Shuttle sweep

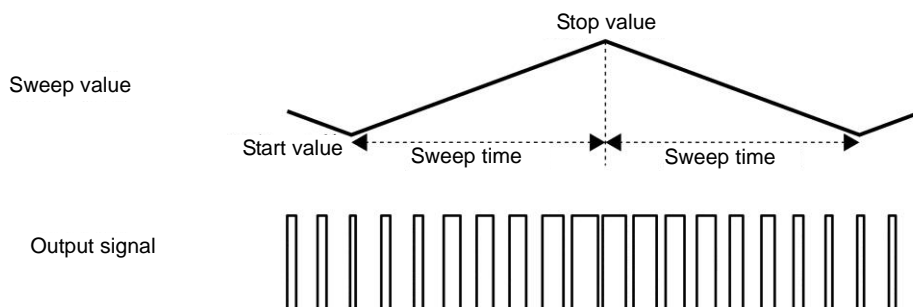

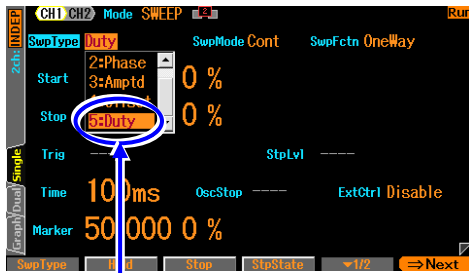
**b) To select duty sweep**

Select [Duty] in the sweep type setting menu

When the oscillation mode [Mode] is set to sweep oscillation mode [SWEEP], select the sweep type [SwpType] on the second page of the setting screen to display the selection list. When [Duty] is pressed, duty sweep is set.

**c) Waveform that duty sweep is available**

Square wave and pulse wave are available.

PWM modulation is canceled (modulation function turned off) when duty sweep is specified.

**d) Setting items necessary for duty sweep**

Set the following items on the second page of the setting screen. The duty setting on page one of the setting screen becomes invalid and the current duty is displayed.

- Start duty [Start]
 

The range of duty depends on the frequency. Pulse wave further depends on the rising and falling times. ☞ P.4-44, P.4-46
- Stop duty [Stop]
 

The range of duty depends on the frequency. Pulse wave further depends on the rising and falling times. ☞ P.4-44, P.4-46
- Sweep time [Time]
 

Time to change from the starting duty to the stop duty. ☞ P.4-74
- Sweep Mode [SwpMode]
 

Select from continuous, single, or gated single. ☞ P.4-75
- Sweep function [SwpFctn]
 

Select from one-way, shuttle. ☞ P.4-75

It is possible to set with center duty [Center] and span duty [Span], instead of start duty and stop duty. ☞ P.4-74

When sweep mode is single or gated single, it is necessary to set the trigger condition [Trig]. ☞ P.4-77

Set the following items as needed:

- Marker duty [Marker] (second page of the setting screen) ☞ P.4-79
- Stop level [StpLvl] (second page of the setting screen) ☞ P.4-76
 

The setting used for gated single sweep only.
- Oscillation stop unit of the gated single sweep [OscStop] (second page of the setting screen) ☞ P.4-76
 

The setting used for gated single sweep only.
- Synchronization/sub output selection [SubOut] (third page of the setting screen) ☞ P.4-79

## 4.9 Setting and Operation of Burst

### 4.9.1 Burst Oscillation Types(Burst mode)

The following 4 types of burst oscillations are available.

- Auto burst  
Repeat oscillation and stop automatically at the specified by waveform respectively. A trigger signal is not necessary. (P.4-90)
- Trigger burst  
Every time a trigger is accepted, perform oscillation with the specified frequency. (P.4-93)
- Gate Oscillation  
While the gate is On, performs an oscillation with an integer cycle or half-cycle unit. (P.4-98)
- Triggered Gate Oscillation  
Gate oscillation that turns the gate On/Off every time a trigger is accepted. (P.4-102)

### 4.9.2 Screen for Setting and Operation of Bursts

This section describes the common screen structure in the burst oscillation mode.

Settings and operations are performed in the Oscillator setting screen. When you press the MENU key while another screen is displayed, the Top menu is displayed. Select [Oscillator] and then press the ENTER key.

#### a) To set oscillation mode as burst

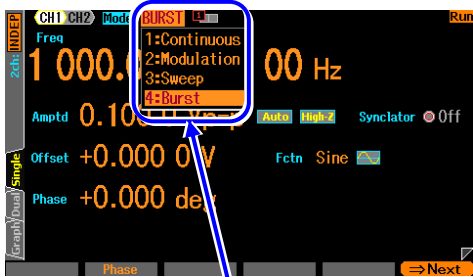

Press the MODE key to open the oscillation mode selection list. Select the burst oscillation mode [Burst]. (P.4-27) This switches to burst oscillation mode.

There are 3 pages of setting screens in total in the burst oscillation mode. You can switch pages by using the NEXT soft-key.

To set the oscillation mode to [Burst] (P.4-27)

#### b) First page of the setting screen: Basic parameter setting screen

These are common items which are independent of the oscillation mode.

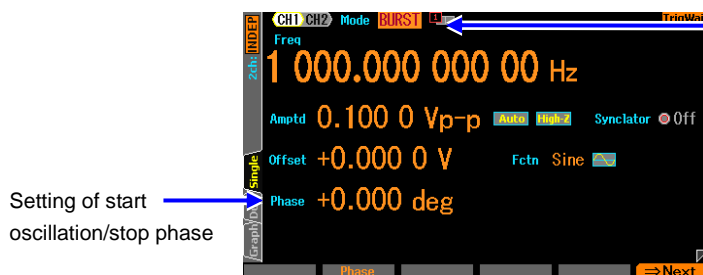

Indicates that the first page is displayed

Pressing the NEXT key switches the display to the second page

#### c) Second page of the setting screen: Screen for Setting Bursts

Settings differ depending on the burst mode. This is explained for each burst mode.

**d) Third page of the setting screen: screen for setting the modulation function and synchronization/sub output terminal**

The following figure is an example of selecting FM as a modulation type.

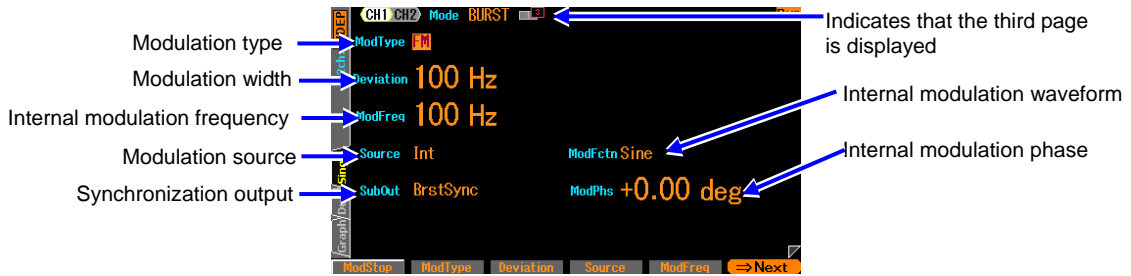

○ Modulation type [ModType]

These are the types of modulation. Select from FM, FSK, PM, PSK, AM, AM (DSB-SC), DC offset modulation, and Off. ☞ P.4-58

FSK and PSK cannot be selected in burst oscillation mode except when using auto burst [AutoBurst].

Even during the oscillation also stopped always modulation acts. When the level in the PM of stopping at a constant level, please use by the stop level on.

○ Synclator synchronization source [SyncSrc]

This only appears when the Synclator function is turned on in auto burst [AutoBurst]. This oscillation frequency synchronizes with the synchronization source specified here. The selection list is as follows: ☞ P.4-32

Channel 1	Channel 2 (WF1968 only)
CH1 trigger input terminal [Ext]	CH2 trigger input terminal [Ext]
-	CH1 trigger input terminal [Ch1]

The polarity can also be selected.

○ Modulation width [Deviation, Depth, HopFreq]

This is the modulation width. The item name changes with the modulation type. ☞ P.4-58

The modulation signal will have no effect on the main signal when the modulation width is set to 0. Selecting internal for the modulation source and internal modulation waveform in [SubFctn] the sub output selection [SubOut] will output an internal modulation signal from the synchronization/sub output BNC terminal. At this time, the internal modulation signal can be used as an independent signal source by freely setting the waveform, frequency, phase, amplitude, and DC offset.

○ Modulation source [Source]

Select internal [Int] or external [Ext] for the modulation source. ☞ P.4-58

Additionally, [Ch1] may be selected on channel 2 as on channel 1. (WF1968 only)

[Ch1] can only be selected when the modulation mode is FSK or PSK and the channel 1 modulation source is set to [Int].

○ Internal modulation frequency [ModFreq]

This is the frequency of the internal modulation source. ☞ P.4-58

This item is not available when the modulation function is off or set to external modulation.

○ Internal modulation waveform [ModFctn]/Sub waveform [SubFctn]

Sets the waveform for the internal modulation source when the modulation function is turned on and set to internal modulation. Select from the sine wave, square wave, triangle wave, rising ramp wave, falling ramp wave, noise, and arbitrary wave. ☞ P.4-58

Selects the sub waveform sent to the sub output when the modulation function is turned off or not set to internal modulation.

○ Internal modulation phase [ModPhs] /Sub waveform phase [SubPhs]

This is the phase of the internal modulation source when the modulation function is turned on and set to internal modulation. Changes the phase difference between the reference phase of the internal modulation source and the waveform output.

Sets the sub waveform phase sent to the sub output when the modulation function is turned off or set to external modulation.

○ Sub output selection [SubOut]

Selects the output signal from the synchronization/sub output terminal. Choose from the selection list. P.4-59

- Sub output amplitude [SubAmp]  
Sets the output amplitude when the internal modulation waveform and sub waveform are selected as the output signal from the synchronization/sub output terminal.
- Sub output offset [SubOfs]  
Sets the output offset when the internal modulation waveform and sub waveform are selected as the output signal from the synchronization/sub output terminal.

### 4.9.3 Auto burst

Repeat oscillation and pause automatically at the specified by waveform respectively. A trigger signal is not necessary.

#### a) Auto burst example

Mark wave number (oscillation wave number): 3 waves, space wave number (stop oscillation wave number): 2 waves, start oscillation/stop phase: 30 degree, stop level: In case of Off.

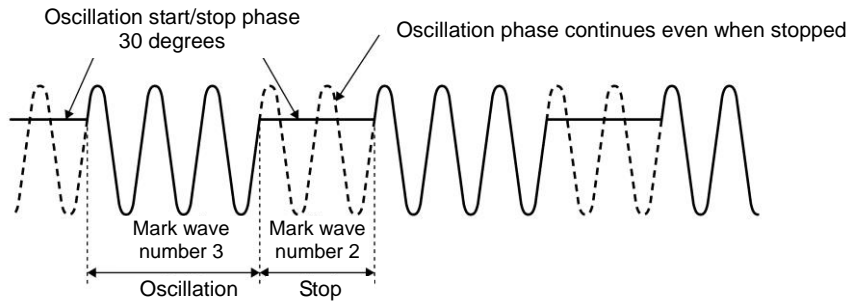

#### b) To set burst mode as auto burst

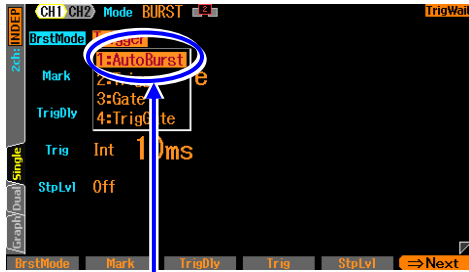

Select [AutoBurst] on the burst mode setting menu

Select burst oscillation mode [BrstMode] on the second page of the setting screen, and press the ENTER key to display the burst mode selection list. Selecting auto burst [AutoBurst] sets the auto burst mode.

#### c) Screen for auto burst setting(second page)

Set the burst mode to [AutoBurst]

Mark wave number → Mark 1.0 cycle

Space wave number → Space 1.0 cycle

Stop level → StpLvl Off

Indicates that the second page is displayed

Pressing the NEXT key switches the display to the first page

- Burst mode [BrstMode]  
Set the burst mode. Set the mode here to auto burst [Auto].
- Mark wave number [Mark]  
The wave number of oscillation. 0.5 This can be set in cycle unit. Usually, set to 1 cycle unit.
- Space wave number [Space]



The wave number to stop oscillation. 0.5 This can be set in cycle unit. Usually, set to 1 cycle unit.

○ Stop level [StpLvl]

The signal level while oscillation is stopped. Set the level by specifying Off or On. ☞ P.4-92

**d) Waveform that auto is unavailable**

Noise and DC cannot perform auto burst.

**e) Setting items necessary for auto burst**

Set the oscillation start/stop phase [Phase] on the first page of the setting screen.

Set mark wave number [Mark] and space wave number [Space] on the second page of the setting screen.

Each wave number is usually set as integer value.

The stop level [StpLvl] on the second page of the setting screen is usually set as Off [Off].

☞ P. 4-97

**f) To start auto burst → Started automatically**

In auto burst mode, burst starts automatically when entering in burst-oscillation mode. However, if the sweep setting is not appropriate, the burst oscillation will not start ([Conflict] is displayed in the channel status area). When pressing the soft-key [?] displayed on the left end, the message concerning an improper setting appears. When that is changed to a proper setting, burst oscillation starts. ☞ P.14-9

**g) To stop auto burst → Cannot**

Oscillation cannot be stopped while in auto burst mode.

To stop oscillation, set the burst mode [BrstMode] to a setting other than auto burst [Auto] on the second page of the setting screen to prevent a trigger or gate signal from arriving.

To set as continues oscillation, change the oscillation mode to [CONT].

**h) To output a burst synchronization signal → In the synchronization/sub output settings**

Set synchronization output [SyncOut] on the third page of the setting screen. Select from following table.

Modulation function on and internal modulation	Modulation function off or external modulation
Waveform reference phase synchronization[Sync]	Waveform reference phase synchronization[Sync]
Burst synchronization [BrstSync]	Burst synchronization[BrstSync]
Internal modulation synchronization [ModSync]	-
Internal modulation waveform [ModFctn]	Sub waveform [SubFctn]
Output disabled [Off]	Output disabled [Off]

■ When [Sync] is selected

Signals with TTL level that are rising at the reference phase of waveform are output from the synchronization/sub-output terminal.

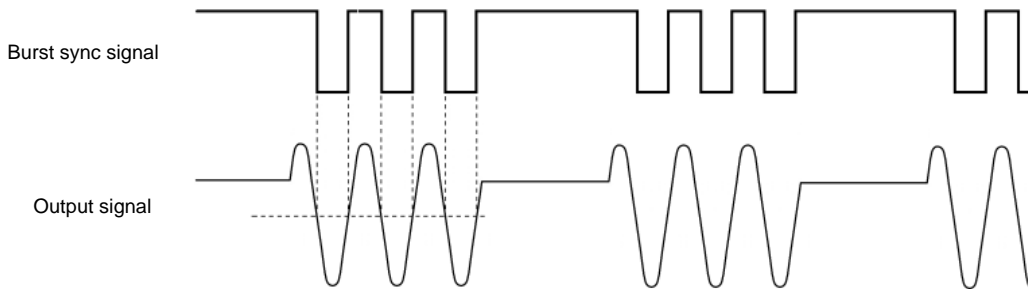

■ When [BrstSync] is selected

Signals with TTL level that synchronize with the burst oscillation are output from the synchronization/sub-output terminal. It is low during oscillation and high while oscillation is stopped, as show in the following figure.

When a signal under burst is observed with the oscilloscope etc., it can be used as a trigger signal of the oscilloscope.

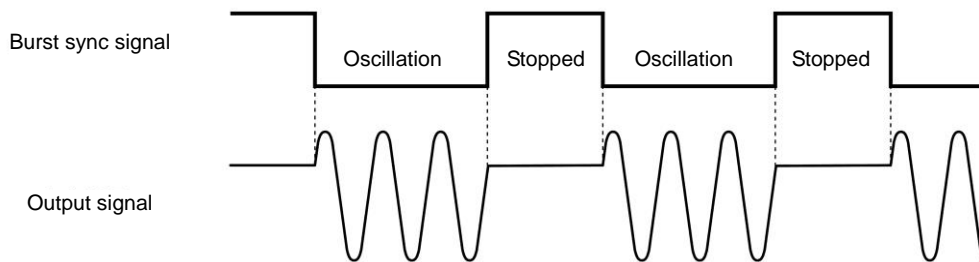

■ When [Off] is selected

The output will be low level. This helps to reduce interference from the common GND of externally connected devices or the synchronization output signal.

i) **How to use stop level**

The level while oscillation is stopped is usually set by oscillation start/stop phase. It is also possible to set by the ratio to the full scale of the amplitude independently.

Set the stop level [StpLvl] as On [On] on the second page of the setting screen, and set the level with % value. ☞ P.4-97

### 4.9.4 Trigger burst

Every time a trigger is accepted, perform oscillation with the specified cycle(s).

#### a) Trigger burst example

Mark wave number (oscillation wave number): 4 waves, start oscillation/stop phase: 30 degrees, stop level: In case of Off.

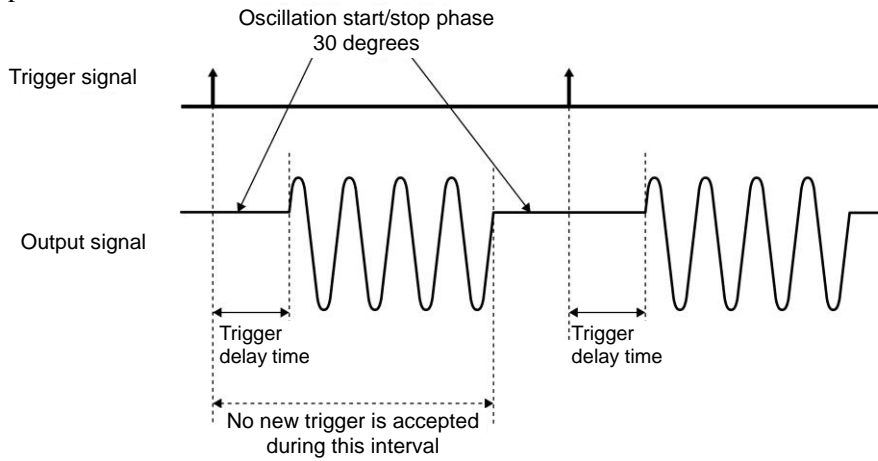

#### b) To set burst mode to trigger burst



Select [Trigger] on the burst mode setting menu

Select burst oscillation mode [BrstMode] on the second page of the setting screen, and press the ENTER key to display the burst mode selection list. Selecting trigger burst [Trigger] sets the trigger burst mode.

Setting trigger burst will force quit the Synclator function.

## c) Screen for trigger burst setting(second page)

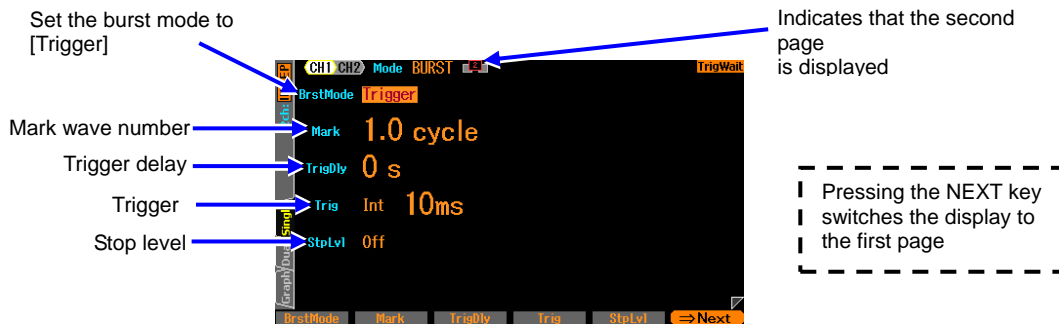

## ○ Burst mode [BrstMode]

Set the burst mode. This sets the trigger burst [Trigger].

## ○ Mark wave number [Mark]

The wave number oscillating every time a trigger is accepted. 0.5 This can be set in cycle unit.

## ○ Trigger delay [TrigDly]

Trigger delay time. Start oscillation when the specified time elapses after accepting a trigger.

☞ P.4-95

## ○ Trigger [Trig]

The trigger condition. Select as a trigger source from the inside or outside. ☞ P.4-95

## ○ Stop level [StpLvl]

The signal level while oscillation is stopped. Set the level by specifying Off or On. ☞ P.4-97

## d) Waveform that trigger is unavailable

Noise and DC cannot perform trigger burst.

## e) Setting items necessary for trigger burst

Set the oscillation start/stop phase [Phase] on the first page of the setting screen.

Set mark wave number [Mark] on the second page of the setting screen.

The stop level [StpLvl] on the second page of the setting screen is usually set as Off [Off].

☞ P.4-97

A trigger is necessary for trigger burst. See the next section.

**f) Trigger setting for trigger burst**

Internal trigger oscillator, external signal, manual trigger key operation, and remote trigger can be used as a trigger.

When a trigger is received, the TRIG'D lamp on the TRIG key lights up.

Set the trigger source in the trigger [Trig] on the second page of the setting screen

**■ Trigger source setting**

A trigger source can be selected from internal [Int] or external [Ext].

When a trigger source is internal [Int], a trigger cycle can be set.

When a trigger source is external [Ext], the polarity of a trigger can be set.

When a trigger source is external [Ext], enter a trigger signal with a TTL level to the external trigger input terminal (TRIG IN).

In addition to the settings above, channel 2 can select the channel 1 trigger source [Ch1]. (WF1968 only) In this case, the trigger source selected in channel 1 is shared.

**■ How to use manual and remote triggers**

Manual trigger operation and remote trigger operation is effective, regardless of the trigger source setting.

The TRIG key can be used for manual trigger operation.

However, in the case of WF1968, the TRIG key only works on the channel side where the display is active. For the channel where the display is active, [☞ P.4-20](#)

When only manual trigger operation and remote trigger operation are used for a trigger, set the trigger source as external [Ext]. Moreover, we will recommend that the polarity is set as [Off] to avoid malfunctions caused by exogenous noise.

**■ Trigger delay setting**

Set the trigger delay time in the trigger delay [TrigDly] on the second page of the setting screen

Start oscillation when the specified time elapses after accepting a trigger. The setting of trigger delay time is effective for all trigger sources.

The delay inside the equipment is minimized when the trigger delay time is set as zero, however, there is a delay in the waveform actually output. [☞ P. 17-19](#)

A new trigger is not accepted until oscillation of the specified number of mark waves completes.

**g) To start trigger burst → trigger**

When a trigger is accepted, perform oscillation with the specified cycle(s).

Internal trigger oscillator, external signal, manual trigger operation, and remote trigger can be used as a trigger.

### h) To output a burst synchronous signal → In the synchronous output setting

Set synchronization output [SyncOut] on the third page of the setting screen. Select from following table.

Modulation function on and internal modulation	Modulation function off or external modulation
Waveform reference phase synchronization[Sync]	Waveform reference phase synchronization[Sync]
Burst synchronization [BrstSync]	Burst synchronization[BrstSync]
Internal modulation synchronization [ModSync]	-
Internal modulation waveform [ModFctn]	Sub waveform [SubFctn]
Output disabled [Off]	Output disabled [Off]

#### ■ When [Sync] is selected

Signals with TTL level that are rising at the reference phase of waveform are output from the synchronization/sub-output terminal.

#### ■ When [BrstSync] is selected

Signals with TTL level that synchronize with the burst oscillation are output from the synchronization/sub-output terminal. It is low during oscillation and high while oscillation is stopped, as show in the following figure.

When a signal under burst is observed with the oscilloscope etc., it can be used as a trigger signal of the oscilloscope.

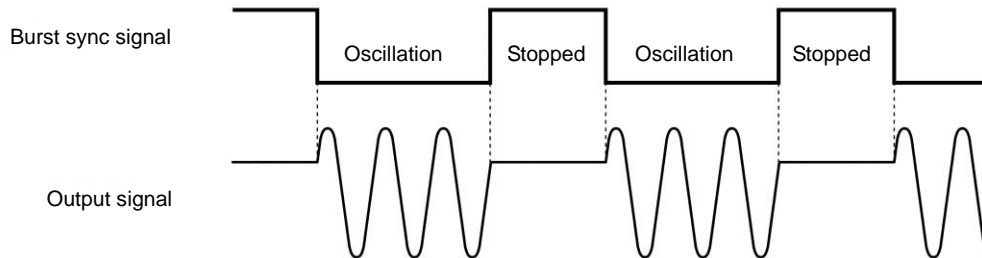

#### ■ When [Off] is selected

The output will be low level. This helps to reduce interference from the synchronization output signal.

**i) How to use stop level**

The level while oscillation is stopped is usually set by oscillation start/stop phase. It is also possible to set by the ratio to the full scale of the amplitude independently.

Set the stop level [StpLvl] as On [On] on the second page of the setting screen, and set the level with % value.

The example in the following figures, mark wave number 3 waves, oscillation start/stop phase 30 degrees, stop level is OFF or ON and -50%. Note that start oscillation/stop phase is still effective.

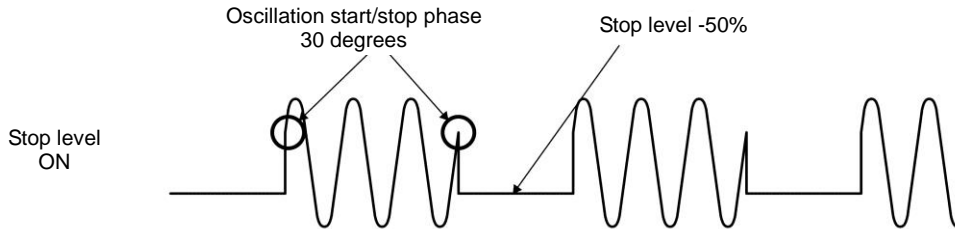
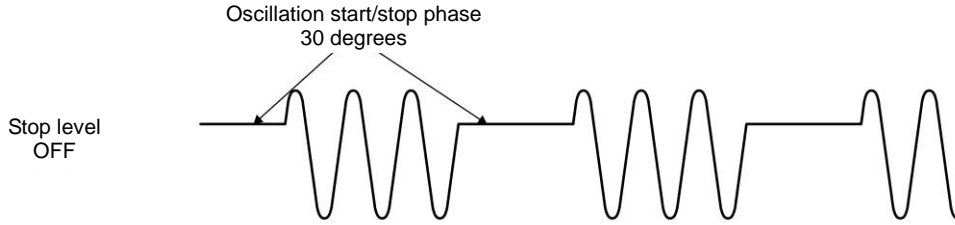

When you the stop level is applied to the square wave, a square wave with three values can be output as shown in the following figure.

In the figure example, the stop level is set as 0%, start oscillation/stop phase are set as 0° (both the standard and enhanced duty variable ranges are available). If the stop level is not applied, the level of square wave while oscillation is stopped is always either of low level or high level.

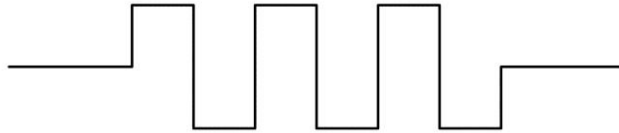

### 4.9.5 Gate Oscillation

While the gate is On, performs an oscillation with an integer cycle or half-cycle unit.

#### a) Gate oscillation example

Start oscillation/stop phase: 30 degrees, Oscillation stop unit: 1 cycle, Stop level: In case of Off. The oscillation is stopped when reaching the start oscillation/stop phase after the gate signal is Off.

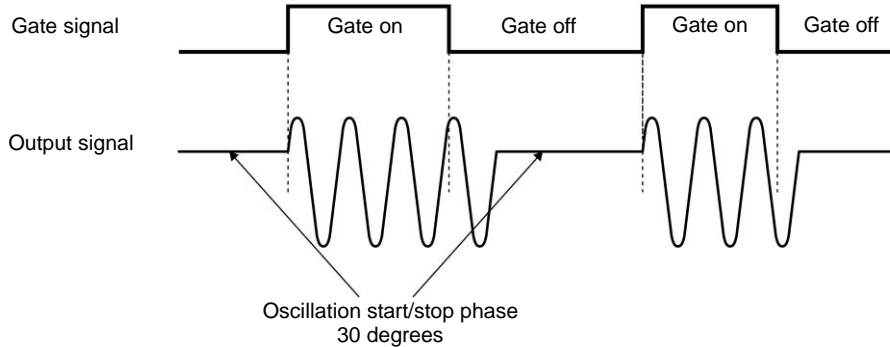

#### b) To set burst mode as gate oscillation

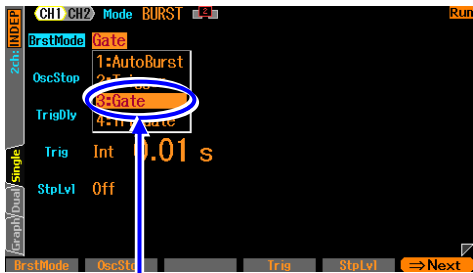

Select [Gate] on the burst mode setting menu

Select burst oscillation mode [BrstMode] on the second page of the setting screen, and press the ENTER key to display the burst mode selection list. Selecting gate oscillation [Gate] sets the gate oscillation mode.

Setting gate oscillation force quits the Synclator function.

#### c) Screen for gate oscillation setting (second page)



- Burst mode [BrstMode]  
Set the burst mode. Set the mode here to gate oscillation [Gate].
- Oscillation Stop Unit [OscStop]  
The oscillation stop unit. Select from 1 cycle and half cycle. ☞ P.4-100
- Trigger [Trig]  
The trigger condition (gate condition). Select as a trigger source from the inside or outside.  
☞ P.4-99
- Stop level [StpLvl]  
The signal level while oscillation is stopped. Set the level by specifying Off or On. ☞ P.4-101



**d) Waveform that gate oscillation is unavailable**

DC cannot perform gate oscillation. Noise can perform gate oscillation, however, the action differs from other waveforms. ☞ P.4-101

**e) Setting items necessary for gate oscillation**

Set the oscillation start/stop phase [Phase] on the first page of the setting screen.

The stop level [StpLvl] on the second page of the setting screen is usually set as Off [Off].

☞ P.4-101

The oscillation stop unit [OscStop] on the second page of the setting screen is usually set as 1 cycle [Cycle]. ☞ P.4-100

A trigger (gate) is necessary for gate oscillation. See the next section.

**f) Trigger (gate) setting for gate oscillation**

Internal trigger oscillator, external signal, manual trigger operation, and remote trigger can be used as a trigger (gate).

While a gate signal is On, the TRIG'D lamp above the TRIG key lights up.

Set the trigger source in the trigger [Trig] on the second page of the setting screen. The trigger delay is fixed to the minimum value.

**■ Trigger source setting**

A trigger source can be selected from internal [Int] or external [Ext].

When a trigger source is internal [Int], a trigger cycle can be set. At this time, the gate signal is square waves with duty 50%.

When a trigger source is external [Ext], the polarity of a trigger can be set.

In addition, channel 2 can select the channel 1 trigger source [Ch1]. (WF1968 only) In this case, the trigger source selected in channel 1 is shared.

**■ How to use manual and remote triggers**

Manual trigger operation and remote trigger operation is effective, regardless of the trigger source setting.

The TRIG key can be used for manual trigger operation.

While the TRIG key is pressed, the gate signal is On. However, in case of the WF1968, the TRIG key works for the channel whose display is active.

For the channel where the display is active, ☞ P.4-20

When only manual trigger operation and remote trigger operation are used for a trigger, set the trigger source as external [Ext]. Moreover, we will recommend that the polarity is set as [Off] to avoid malfunctions caused by exogenous noise.

**g) To start gate oscillation → Trigger (gate signal)**

When gate signal On is accepted, oscillation starts.

Internal trigger oscillator, external signal, manual trigger operation, and remote trigger can be used as a trigger.

**h) To output a burst synchronous signal → Synchronous output setting**

Set synchronization/sub output [SubOut] on the third page of the setting screen. Select from following table.

Modulation function on and internal modulation	Modulation function off or external modulation
Waveform reference phase synchronization[Sync]	Waveform reference phase synchronization[Sync]
Burst synchronization [BrstSync]	Burst synchronization[BrstSync]
Internal modulation synchronization [ModSync]	-
Internal modulation waveform [ModFctn]	Sub waveform [SubFctn]
Output disabled [Off]	Output disabled [Off]

- When [Sync] is selected

Signals with TTL level that are rising at the reference phase of waveform are output from the synchronization/sub-output terminal.

- When [BrstSync] is selected

Signals with TTL level that synchronized with the gate oscillation are output from the synchronization/sub-output terminal. It is low during oscillation and high while oscillation is stopped, as show in the following figure. Note that it is different from a gate signal.

When a signal under burst is observed with the oscilloscope etc., it can be used as a trigger signal of the oscilloscope.

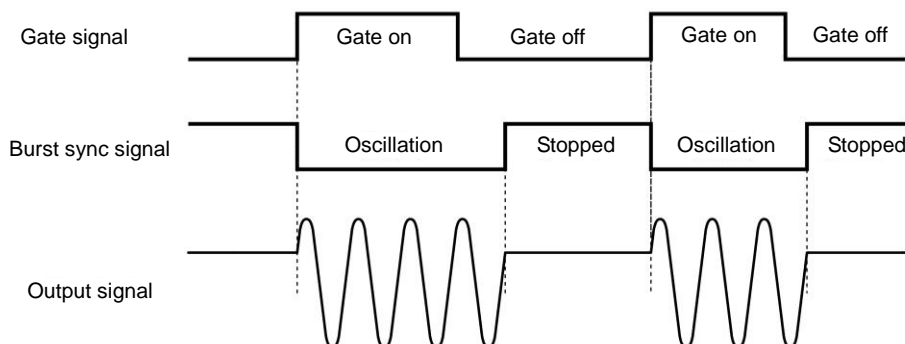

- When [SubFctn] is selected (only when modulation function is off or using external modulation)

Outputs a sub waveform from the synchronization/sub output BNC terminal. The frequency is same as main output. The waveform, amplitude, offset and phase are settable independently from main output.

- When [Off] is selected

The output will be low level. This helps to reduce interference from the synchronization output signal.

**i) To oscillate in half cycle → Oscillation stop unit as half cycle**

When you want to stop oscillation every half cycle, set the oscillation stop unit [OscStop] as half cycle [HalfCycle] on the second page of the setting screen. Usually, set to 1 cycle [Cycle]. When it is set to 1 cycle [Cycle], the oscillation has an integer cycle.

The following figure shows the comparison for the cases of one cycle and half cycle. Start oscillation/stop phase: 30 degrees, stop level: In case of Off.

In the case of 1 cycle unit, the oscillation is stopped when reaching the start oscillation/stop phase after gate is Off.

In the case of a half cycle unit, the oscillation is stopped when reaching the start oscillation/stop phase or the start oscillation/stop phase + 180 degrees (or -180 degrees) after gate is Off, and then it transits to the start oscillation/stop phase.

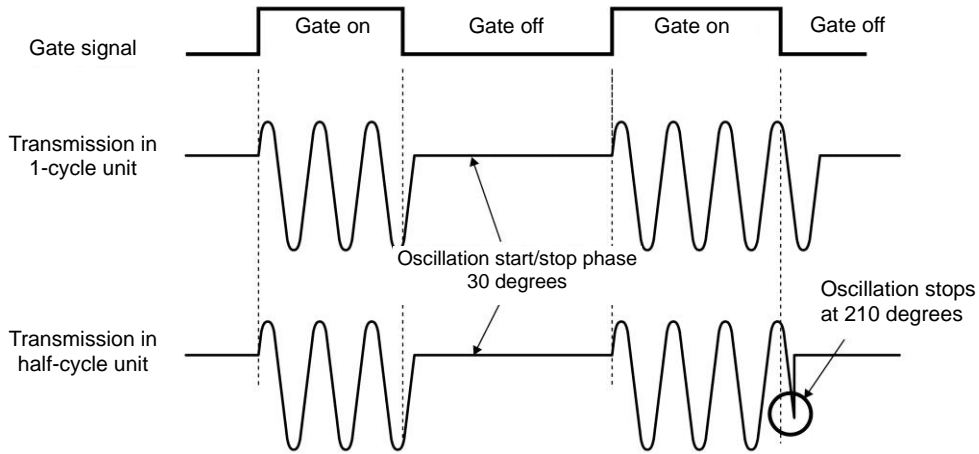

**j) How to use stop level**

The level while oscillation is stopped is usually set by oscillation start/stop phase. It is also possible to set by the ratio to the full scale of the amplitude independently.

Set the stop level [StpLvl] as On [On] on the second page of the setting screen, and set the level with % value. P.4-97

**k) Noise gate oscillation**

Because noise has no cycle, the gate On zone is the oscillation zone directly, and the gate Off zone is the oscillation zone directly. In addition, because noise has no phase, a stop level setting is very effective.

The following figure shows the example of noise gate oscillation. That is the case with stop level of 0%.

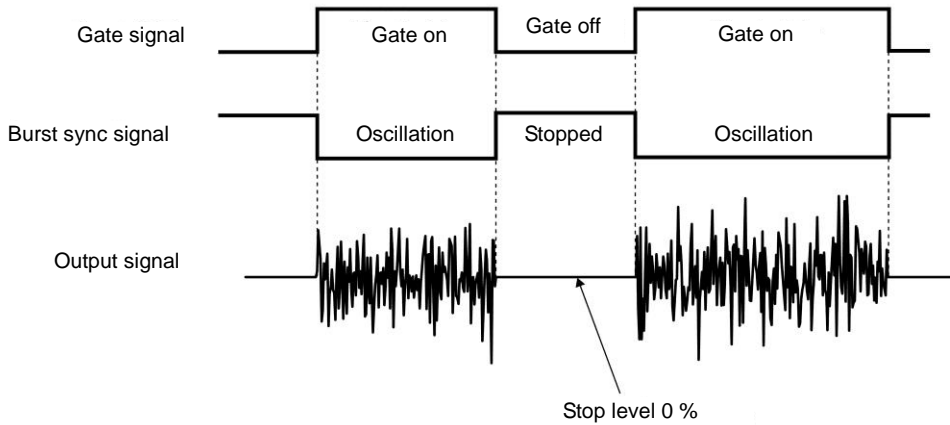

### 4.9.6 Triggered Gate Oscillation

Gate oscillation that turns the gate On/Off every time a trigger is accepted.

**a) Triggered gate oscillation example**

Start oscillation/stop phase: 30 degrees, Oscillation stop unit: 1 cycle, Stop level: In case of Off.

The oscillation is stopped when reaching the start oscillation/stop phase after the gate signal is Off.

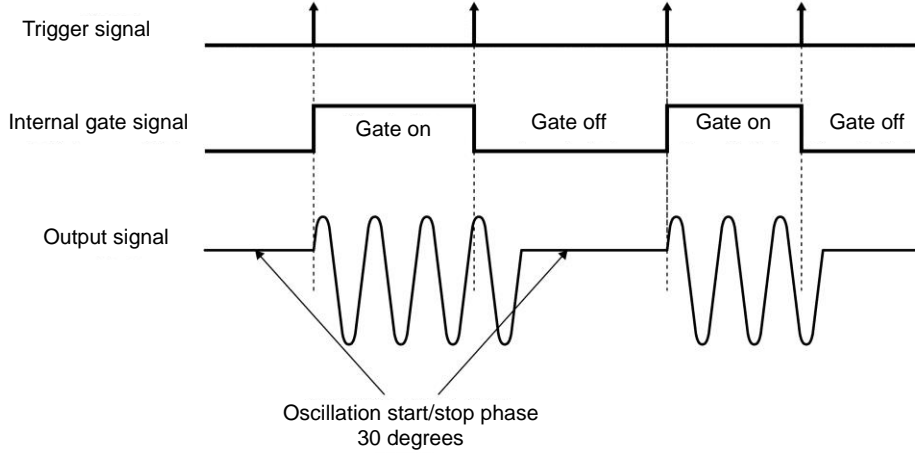

**b) To set burst mode as triggered gate oscillation**

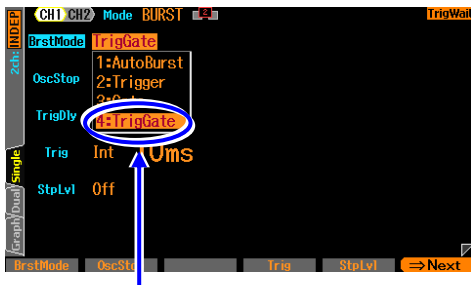

Select burst oscillation mode [BrstMode] on the second page of the setting screen, and press the ENTER key to display the burst mode selection list. Selecting triggered gate oscillation [TrigGate] will set the triggered gate oscillation mode.

Select [TrigGate] on the burst mode setting menu

Setting triggered gate oscillation force quits the Synclator function.

## c) Screen for triggered gate oscillation setting (second page)

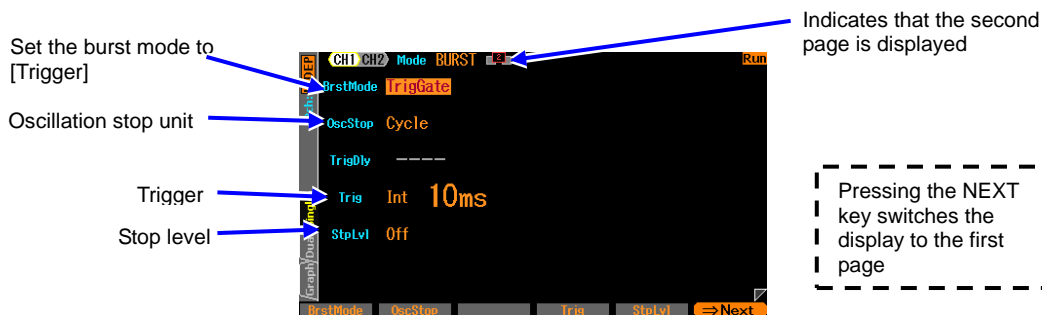

## ○ Burst mode [BrstMode]

Set the burst mode. This sets the triggered gate oscillation [TrigGate].

## ○ Oscillation Stop Unit [OscStop]

The oscillation stop unit. Select from 1 cycle unit and half period unit. ☞ P.4-104

## ○ Trigger [Trig]

The trigger condition.

Select as a trigger source from the inside or outside. ☞ P.4-103

## ○ Stop level [StpLvl]

The signal level while oscillation is stopped. Set the level by specifying Off or On. ☞ P.4-105

## d) Waveform that trigger gate oscillation is unavailable

DC cannot perform triggered gate oscillation.

Noise can perform triggered gate oscillation, however, the action differs from other waveforms.

☞ P.4-105

## e) Setting items necessary for triggered gate oscillation

Set the oscillation start/stop phase [Phase] on the first page of the setting screen.

The stop level [StpLvl] on the second page of the setting screen is usually set as Off [Off].

☞ P.4-105

The oscillation stop unit [OscStop] on the second page of the setting screen is usually set as 1 cycle [Cycle]. ☞ P.4-104

A trigger is necessary for triggered gate oscillation. See the next section.

## f) Trigger setting of triggered gate oscillation

Internal trigger oscillator, external signal, manual trigger key operation, and remote trigger can be used as a trigger.

When a trigger is received, the TRIG'D lamp on the TRIG key lights up.

Set the trigger source in the trigger [Trig] on the second page of the setting screen. The trigger delay is fixed to the minimum value.

## ■ Trigger source setting

A trigger source can be selected from internal [Int] or external [Ext].

When a trigger source is internal [Int], a trigger cycle can be set.

When a trigger source is external [Ext], the polarity of a trigger can be set.

When a trigger source is external [Ext], enter a trigger signal with a TTL level to the external trigger input terminal (TRIG IN).

In addition, channel 2 can select the channel 1 trigger source [Ch1]. (WF1968 only) In this case, the trigger source selected in channel 1 is shared.

## ■ How to use manual and remote triggers

Manual trigger operation and remote trigger operation is effective, regardless of the trigger source setting.

The TRIG key can be used for manual trigger operation.

However, in the case of WF1968, the TRIG key only works on the channel side where the display is active. For the channel where the display is active, [☞ P.4-20](#)

When only manual trigger operation and remote trigger operation are used for a trigger, set the trigger source as external [Ext]. Moreover, we will recommend that the polarity is set as [Off] to avoid malfunctions caused by exogenous noise.

**g) To start triggered gate oscillation → Trigger**

When the trigger is accepted and the internal gate signal is On, oscillation starts.

Internal trigger oscillator, external signal, manual trigger operation, and remote trigger can be used as a trigger.

**h) To output a burst synchronization signal → Synchronous output setting**

set synchronization output [SubOut] on the third page of the setting screen. Select from following table.

Modulation function on and internal modulation	Modulation function off or external modulation
Waveform reference phase synchronization[Sync]	Waveform reference phase synchronization[Sync]
Burst synchronization [BrstSync]	Burst synchronization[BrstSync]
Internal modulation synchronization [ModSync]	-
Internal modulation waveform [ModFctn]	Sub waveform [SubFctn]
Output disabled [Off]	Output disabled [Off]

■ When [Sync] is selected

Signals with TTL level that are rising at the reference phase of waveform are output from the synchronization/sub-output terminal.

■ When [BrstSync] is selected

Signals with TTL level that synchronized with the gate oscillation are output from the synchronization/sub-output terminal. It is low during oscillation, and high while oscillation is stopped, as show in the following figure. Note that it is different from a gate signal.

When a signal under burst is observed with the oscilloscope etc., it can be used as a trigger signal of the oscilloscope.

■ When [Off] is selected

The output will be low level. This helps to reduce interference from the synchronization output signal.

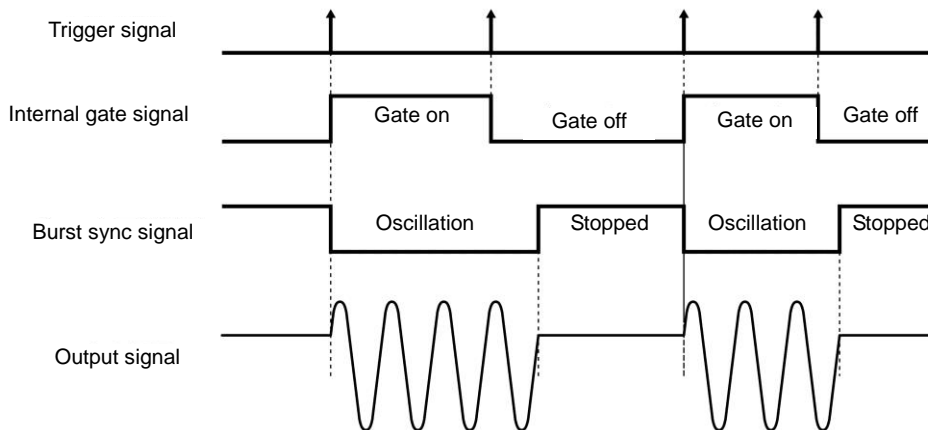

**i) To oscillate in half cycle → Oscillation stop unit as half cycle**

When you want to stop oscillation every half cycle, set the oscillation stop unit [OscStop] as half cycle [HalfCycle] on the second page of the setting screen. Usually, set to 1 cycle [Cycle]. When it is set to 1 cycle [Cycle], the oscillation has an integer cycle.

**j) How to use stop level**

The level while oscillation is stopped is usually set by oscillation start/stop phase. It is also possible to set by the ratio to the full scale of the amplitude independently.

Set the stop level [StpLvl] as On [On] on the second page of the setting screen, and set the level with % value. ☞ P.4-97

**k) Triggered gate oscillation of noise**

Because noise has no cycle, the gate On zone is the oscillation zone, and the gate Off zone is the oscillation zone. In addition, because noise has no phase, a stop level setting is very effective. ☞

P.4-101

MEMO



## 5. Saving and Recalling Settings

5.1	Procedure to Save Settings .....	5-2
5.2	Procedure to Recall Settings .....	5-4
5.3	Restoring Saved Contents to Initial Settings .....	5-6
5.4	Changing Setting Memory Name .....	5-6
5.5	USB Flash Memory Operations .....	5-7

You can save the current setting condition in the setting memory, and call it to use later. Settings are saved on the Store Settings screen and recalled on the Recall Settings screen. When the power is resumed after a power failure, WF1967 or WF1968 will load the contents of the configuration memory 1. *See* P.4-5  
 Factory defaults are saved in all the setting memories at factory shipment.

## 5.1 Procedure to Save Settings

### 5.1.1 To save to build on memory



In the top menu, Select [Store Settings].

1. When the MENU key is pressed, the top menu opens. Then, select [Store Settings]. This opens the Store Settings screen.

Select [Internal Memory No.] on the top right of the screen, and then press the ENTER key to open the input field of the setting memory number to be saved.

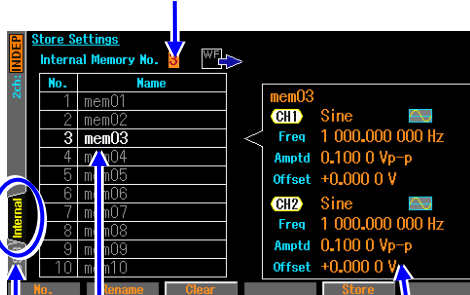

The specified setting memory number and the setting name are highlighted

The overview of the setting in the specified setting memory number is displayed

Select Internal and press the ENTER key.

2. To save on the unit's internal memory, select Internal and press the ENTER key. In the Store Settings screen, select the [Internal Memory No.] field on the top right of the screen, and then press the ENTER key to open the input field of the setting memory number to be saved. Use the up/down arrow keys or the modify knob to increment or decrement the setting memory number. In the left side of the screen, the specified setting memory number and its setting name are highlighted. The overview of the setting saved in the specified setting memory number is displayed on the right side of the screen. Select a setting memory number to save, and then press the ENTER key to close the input field of the setting memory number.

Press the [Store] soft-key to open the dialog box to confirm the save operation.

Select [OK] and then press the ENTER key to save.

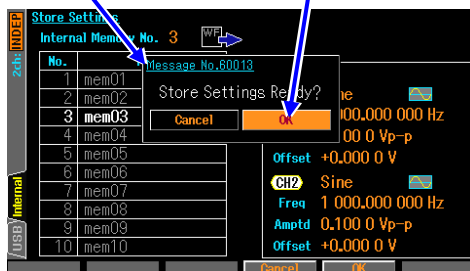

3. Press the [Store] soft-key to open the dialog box to confirm the save operation. If you wish to save, select [OK], and then press the ENTER key. The save is made and the setting previously saved in the setting memory number is overwritten by the new setting.

## 5.1.2 To save to USB flash memory

When USB interface is used, USB memory is not available.

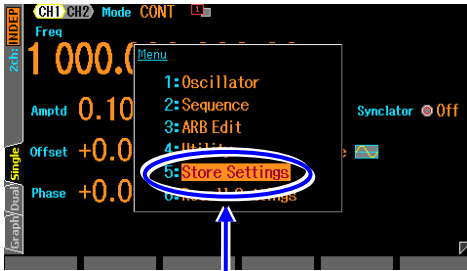

In the top menu,  
Select [Store Settings].

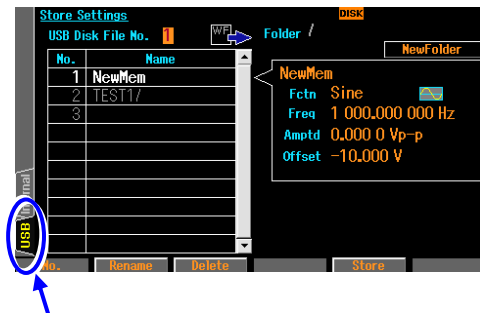

Select USB tab and press  
the ENTER key.

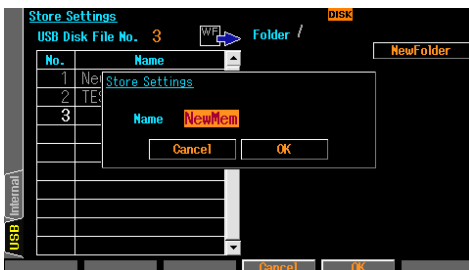

1. When the MENU key is pressed, the top menu opens. Then, select [Store Settings]. This opens the Store Settings screen.
2. When saving to USB, first connect the USB flash memory to the unit, then select the USB tab on the far left of the screen and press the ENTER key. In the Store Settings screen, select the [USB Disk File No.] field on the top left of the screen, and then press the ENTER key to open the input field of the setting memory number to be saved. Use the up/down arrow keys or the modify knob to increment or decrement the setting memory number. In the left side of the screen, the specified setting memory number and its setting name are highlighted. The overview of the setting saved in the specified setting memory number is displayed on the right side of the screen. When folder (in the last of the name a thing with "/") is selected and pushed Enter soft key, move to the folder.
3. If you are newly saved, select the last number in the [USB Disk File No.]. Press the [Store] soft key. Then enter the file name and press the [OK] soft key to save. When you chose an existing number, or when you specify a file name that already exists, it opens a dialog box to confirm overwrite. If you wish to save, select [OK], and then press the ENTER key.

## 5.2 Procedure to Recall Settings

### 5.2.1 To recall from build on memory

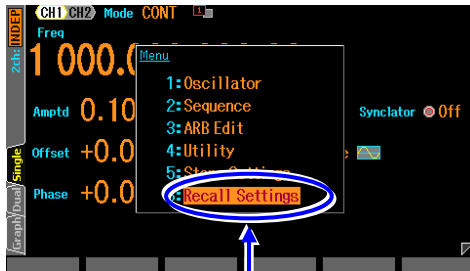

In the top menu, Select [Recall Settings].

Select [Internal Memory No.] on the top right of the screen, and then press the ENTER key to open the input field of the setting memory number to be saved.

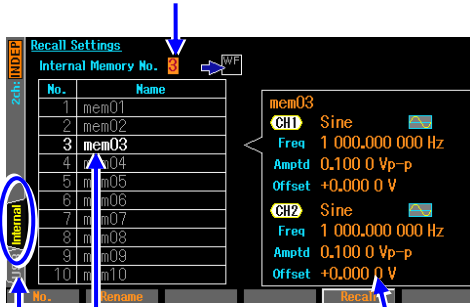

The specified setting memory number and the setting name are highlighted

The overview of the setting in the specified setting memory number is displayed

Select Internal tab.

1. When the MENU key is pressed, the top menu opens. Then, select [Recall Settings]. This opens the Recall Settings screen.

2. To recall settings saved to the unit's internal memory, select Internal and press the ENTER key.

On the Recall Settings screen, select [Internal Memory No.] field on the top right of the screen, and then press the ENTER key to open the input field of the setting memory number to recall.

Use the up/down arrow keys or the modify knob to increment or decrement the setting memory number.

The specified setting memory number and its setting name are highlighted on the far left of the screen.

The overview of the setting saved in the specified setting memory number is displayed on the right side of the screen.

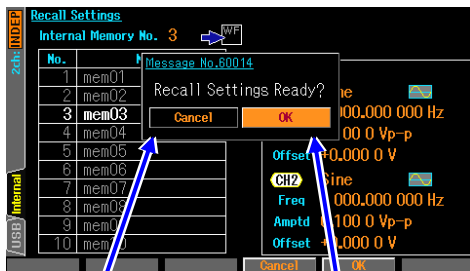

Press the [Recall] soft-key to open the dialog box to confirm the call operation

Select [OK] and then Press the ENTER key to recall the setting.

3. Press the [Recall] soft-key to open the dialog box to confirm the recall operation. If you want to make a call, select [OK], and then press the ENTER key. The setting is recalled, and the current setting is changed.

### 5.2.2 To recall from USB flash memory

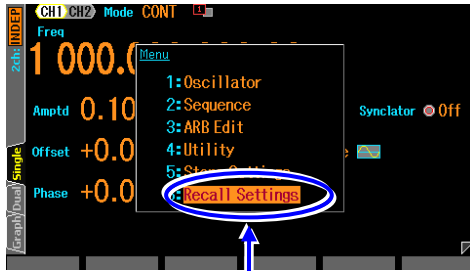

In the top menu, Select [Recall Settings].

Select [Internal Memory No.] on the top right of the screen, and then press the ENTER key to open the input field of the setting memory number to be saved.



The specified setting memory number and the setting name are highlighted

Select USB tab.

1. When the MENU key is pressed, the top menu opens. Then, select [Recall Settings]. This opens the Recall Settings screen.

2. To recall settings saved to USB, first connect the USB flash memory to the unit, then select the USB tab on the far left of the screen and press the ENTER key. On the Recall Settings screen, select [USB Disk File No.] field on the top left of the screen, and then press the ENTER key to open the input field of the setting memory number to recall. Use the up/down arrow keys or the modify knob to increment or decrement the setting memory number. The specified setting memory number and its setting name are highlighted on the far left of the screen. When folder (in the last of the name a thing with "/") is selected and pushed Enter soft key, move to the folder.

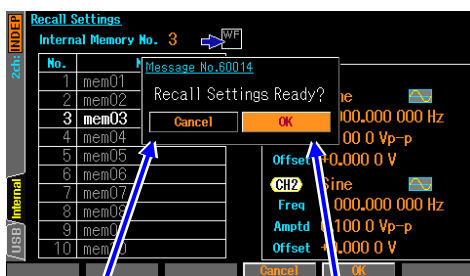

Press the [Recall] soft-key to open the dialog box to confirm the call operation

Select [OK] and then Press the ENTER key to recall the setting.

3. Press the [Recall] soft-key to open the dialog box to confirm the recall operation. If you want to make a call, select [OK], and then press the ENTER key. The setting is recalled, and the current setting is changed.

## 5.3 Restoring Saved Contents to Initial Settings

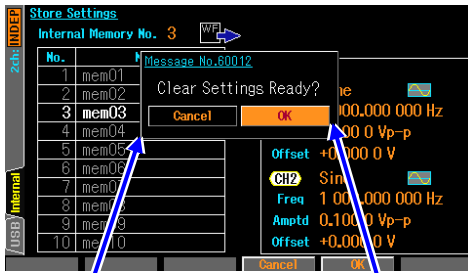

Press the [Clear] soft-key to open the dialog box to confirm the initialization operation.

Select [OK] and then press the ENTER key to return the setting to the initial state

As with the save operation, press the [Clear] soft-key after setting the setting memory number. The dialog box to confirm the initialization operation is opened.

If you wish to initialize the setting, select [OK], and then press the ENTER key. The setting saved previously in the setting memory number is overwritten by the initial setting.

Settings files cannot be run from USB flash memory.

## 5.4 Changing Setting Memory Name



Press the [Rename] soft-key to open the input field of the setting memory name

1. As with the save operation, press the [Rename] soft-key after setting the setting memory number. The input field of the setting memory name is opened.

2. Select the digit to be changed by using the right or left arrow keys, and then use the up or down arrow keys or the modify knob to change the

characters. You can enter uppercase and lowercase alphabetic characters, numbers, and symbols. You can directly enter numbers using the numeric keypad. The maximum number of characters of a name can be 20.

Pressing the [Delete] soft-key deletes the character at the cursor position and shifts the string to the right of the cursor to the left by one character.

Press the [Insert] soft-key to insert a space at the cursor position.

Press the [CLR =>] soft-key to delete the string to the right (excluding the cursor position) of the cursor.

Press the [Clear] soft-key to clear all characters.

3. Press the [Apply] soft-key or the ENTER key to fix the changed name and close the input field of the setting memory name.

Press the CANCEL key to leave the name as it is and close the input field of the setting memory name.

You can also change the setting memory name in the Recall Memory screen.

✓ Check

You can use the following characters for a setting memory name:

A B C D E F G H I J K L M N O P Q R S T U V W X Y Z

a b c d e f g h i j k l m n o p q r s t u v w x y z

0 1 2 3 4 5 6 7 8 9

! # \$ % & ' ( ) \* + , - . / : ; < = > ? @ [ ] ¥ ^ \_ ` { | } ~

Space

The following characters cannot be used when saving to USB flash memory : \* / : < > ?

¥ |

## 5.5 USB Flash Memory Operations

This section explains the unique operations when working with USB flash memory.

### 5.5.1 File List

When working with USB flash memory, the file list for the current folder will appear on the operation screen for saving or recalling settings. Folders directly above the current location are indicated by "../". Folders below the current location are displayed with the list. Unrelated files (not settings files for WF1967 or WF1968) are not displayed.

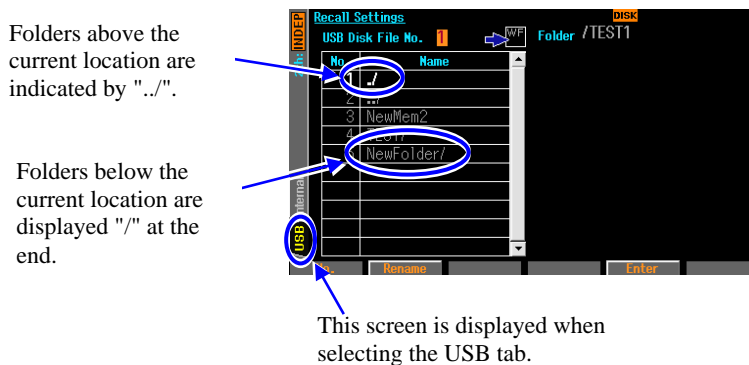

#### ✓ Check

The unit will be unable to display or select files or folders when there are too many items contained in one folder.

Only ASCII characters may be used for file and folder names. Other characters are converted and displayed as a '?' character.

### 5.5.2 To Change the Current Folder

When working with USB flash memory, the saving or recall of settings applies to the files in the current folder.

#### a) Folder directly above

Select the "../" from the file list and press the [Enter] soft-key.

#### b) Folder directly below

Select the name of the folder you wish to move to from the file list and press the [Enter] soft-key.

### 5.5.3 Creating Folders

A [NewFolder] button will appear on the Store Settings screen for USB flash memory. Select this button and press the ENTER key to display a dialog for entering the folder name. Enter the name and press [OK] to create the new folder below the current folder and display it in the file list.

### 5.5.4 Deleting Folders

Similar to the method for general files, select the folder that you wish to delete and press the [Delete] soft-key to display the confirmation dialog. Press the [OK] key to delete the folder. However, an error will occur if the contents of the folder are not empty.

### 5.5.5 Time stamp of files

WF1967/WF1968 does not have a built-in battery, will shift the time of the only time stamp minute of non-energized time. Time stamp of the file that you created in this instrument, is what the date and time

that made the adjustment of the instrument is obtained by adding energizing time. It is not possible to change the date and time for the time stamp.



## 6. Variable Parameter Waveforms

6.1	Categories .....	6-2
6.2	Meaning of Each Parameter and Waveform Examples .....	6-3

## 6.1 Categories

The variable parameter waveforms are categorized into six groups due to their large number.

Selecting a waveform group on the variable parameter waveform selection screen (4-52) allows you to select a waveform to output from the waveforms contained in the group.

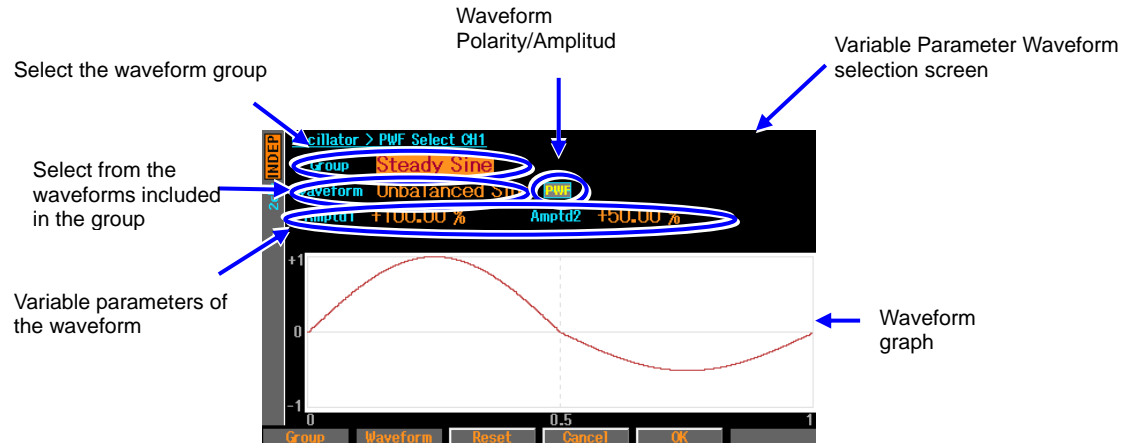

The six groups are as follows:

These names are uniquely created for the sake of convenience when using this product. Also, with the exception of some waveform and parameter names, the names are unique to this product. No matter the name used or the explanations in this chapter, it does not limit how the waveforms can be used.

### ■ Steady Sine Group

Waveform created based on a sine wave. Intended for repeated output.

### ■ Transient Sine Group

Waveform created based on a sine wave. Intended for use as one cycle of the start or end of a continuous sine wave in a sequence oscillation.

### ■ Pulse Group

Pulse shaped waveforms.

### ■ Transient Response Group

Waveform which simulates a system's transient response.

### ■ Surge Group

Waveform which simulates a surge signal.

### ■ Others Group

Waveforms which do not belong to the groups above.

## 6.2 Meaning of Each Parameter and Waveform Examples

### 6.2.1 Outline

The following provides an overview, explains the meaning of each parameter and gives examples for each waveform.

The waveform examples display one cycle of the waveform drawn in the waveform memory. The polarity of the waveform is normal. Because the amplitude range differs for each waveform, the examples use the amplitude range thought to be typical for that waveform.

The vertical axis  $\pm 1$  corresponds to the waveform memory's full scale amplitude  $\pm FS$ .

The horizontal axis is the time axis and represents the time for one cycle with a 1. The horizontal axis also represents the phase axis from 0 to 360°. The time for one period is called the "basic cycle" and the inverse is the "fundamental frequency". Each of these is also the respective oscillation cycle and the oscillation frequency of the entire waveform.

#### ✓ Check

The AC portion of the waveform may disappear depending on the parameter settings. Press the [Reset] soft-key in the center if it is unclear how to restore the settings. This returns each parameter to the default factory settings. Polarity and amplitude range are not changed.

### 6.2.2 Steady Sine Group

#### a) Unbalanced Sine

##### ■ Overview

Sine wave in which the amplitudes of the first half and the latter half of the cycle are independent and can be changed.

Application examples

- Simulation of an output waveform where the gain of the plus side differs from the minus side
- Simulation of full-wave rectification and half-wave rectification waveforms

##### ■ Meaning of each parameter

The example shows the case where the amplitude range is  $\pm FS$ .

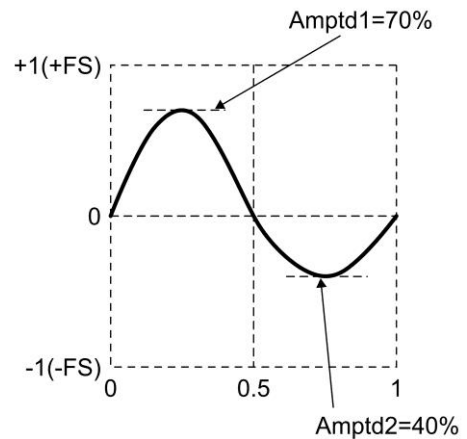

##### • First half amplitude (Amptd1)

The amplitude of the first half cycle.

When it is 100%, the amplitude is the same as the original sine wave.

Variable range: -100.00% to 100.00%

##### • Second half amplitude (Amptd2)

The amplitude of the second half cycle.

When it is 100%, the amplitude is the same as the original sine wave.

Variable range: -100.00% to 100.00%

Please note that when changing each of the amplitudes, the upper and lower peak values for the waveform will change.

Also, when the amplitudes of the first and second halves differ the average value for one cycle will not be zero. Please note that this will generate a DC portion.

##### ■ Waveform examples

The polarity and amplitude range are all Normal,  $\pm FS$ .

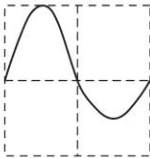
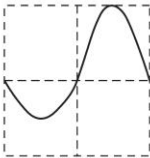
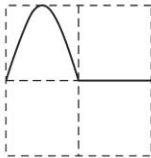
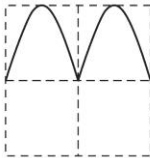
			
Amptd1=100 Amptd2=50	Amptd1=-50 Amptd2=-100	Amptd1=100 Amptd2=0	Amptd1=100 Amptd2=-100

**b) Clipped Sine**

■ Overview

This waveform is a sine wave with the top and bottom clipped.

Application examples

- Simulates a waveform clipped by an input clamp circuit
- Simulates an amp output waveform saturated by the power supply voltage

■ Meaning of each parameter

The example shows the case where the amplitude range is  $\pm FS$ .

• Clip ratio (Clip)

The ratio by which the top and bottom of the original sine wave is clipped.

The peak value of the original sine wave is 100%.

The original sine wave corresponds to the 0% value.

Variable range: 0.00% to 99.99%

Peak value is fixed at  $\pm FS$ .

■ Waveform examples

The polarity and amplitude range are all Normal,  $\pm FS$ .

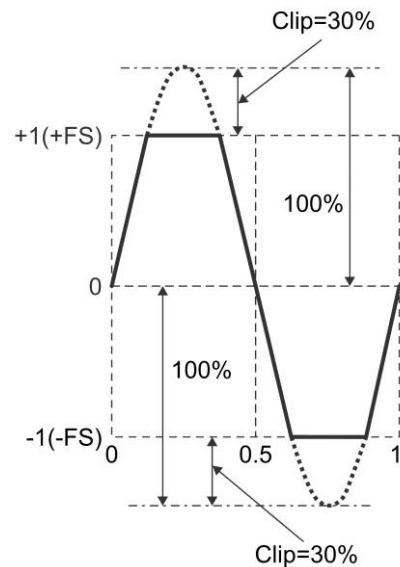

Clip=10	Clip=20	Clip=40	Clip=80

**c) CF Ctrl Sine**

■ Overview

This is a waveform which removes and extends the area around  $90^\circ$  and  $270^\circ$  in a sine wave.

Application examples

- Simulates the current waveform of a condenser input rectifier circuit

■ Meaning of each parameter

The example shows the case where the amplitude range is  $\pm FS$ .

• Crest factor (CF)

The crest factor expresses the ratio of the peak value to the effective value. At a value of 1.41 it is almost equal to the original sine wave.

Variable range: 1.41 to 10.00

Peak value is fixed at  $\pm FS$ .

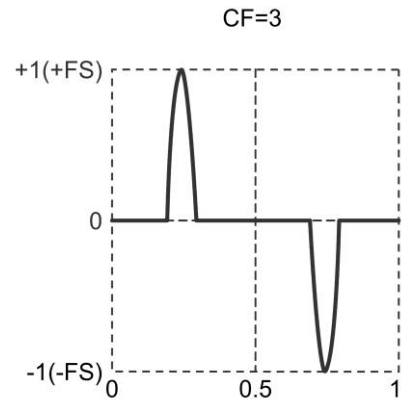

■ Waveform examples

The polarity and amplitude range are all Normal,  $\pm FS$ .

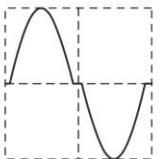
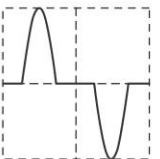
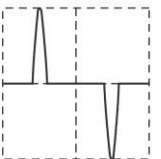
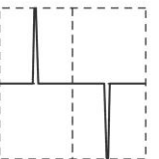
			
CF=1.5	CF=2	CF=3	CF=5

**d) Angle Ctrl Sine**

■ Overview

This is a sine waveform with either the front or back portion of each half cycle removed.

Application examples

- Simulates a thyristor controlled waveform

■ Meaning of each parameter

The example shows the case where the amplitude range is  $\pm FS$ .

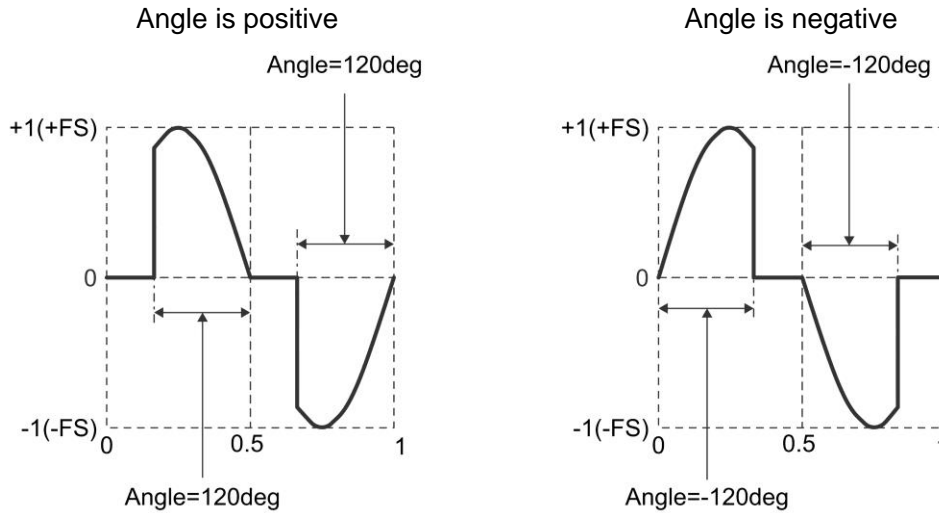

• Conduction angle (Angle)

When the conduction angle is positive, the waveform is a sine wave with the conduction angle portion removed from the back of the half cycle.

When the conduction angle is negative, the waveform is a sine wave with the absolute value portion of the conduction angle removed from the front of the half cycle.

Variable range:  $-180.00^\circ$  to  $180.00^\circ$

The amplitude of the original Sine wave is fixed at  $\pm FS$ . Please note that the amplitude may be less than  $\pm FS$  depending on the value of the conduction angle.

■ Waveform examples

The polarity and amplitude range are all Normal,  $\pm FS$ .

Angle=45	Angle=150	Angle=-45	Angle=-150

**e) Staircase Sine**

■ Overview

This is a sine wave in a staircase pattern.

Application examples

- Simulates the pseudo sine wave output of a UPS (uninterruptible power supply), etc.

■ Meaning of each parameter

The example shows the case where the amplitude range is  $\pm FS$ .

• Steps

The number of stairs. The example at the right is a pseudo sine wave with 4 steps.

Variable range: 2 to 100

Peak value is fixed at  $\pm FS$ .

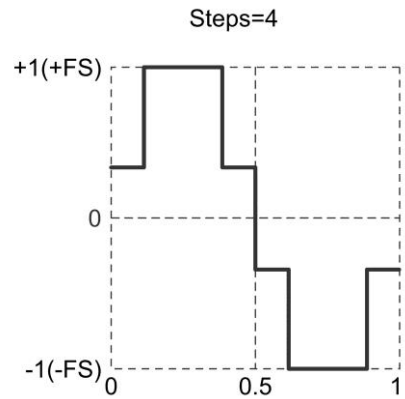

■ Waveform examples

The polarity and amplitude range are all Normal,  $\pm FS$ .

Steps=3	Steps=4	Steps=7	Steps=8



**f) Multi-Cycle Sine**

■ Overview

This is a waveform consisting of multiple, continuous cycles of a sine wave.

Application examples

- Burst wave substitution

■ Meaning of each parameter

The example shows the case where the amplitude range is  $\pm FS$ .

•Cycles

The number of cycles included in one basic cycle.

Variable range: 0.01 to 50.00

•Start Phase (Phase)

The phase of the starting point.

The phase in a frequency the fundamental frequency times Cycles.

Variable range:  $-360.00^\circ$  to  $360.00^\circ$

Peak value is fixed at  $\pm FS$ .

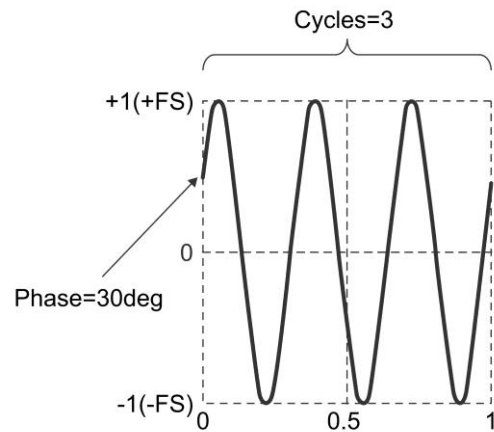

■ Waveform examples

The polarity and amplitude range are all Normal,  $\pm FS$ .

Cycles=3 Phase=0	Cycles=2.5 Phase=0	Cycles=3 Phase=-90	Cycles=2.5 Phase=-90

### 6.2.3 Transient Sine Group

#### a) On-Ph Ctrl Sine

##### ■ Overview

Sine wave which follows a slope during the starting state.

Application examples

- Simulates the output waveform of an AC power supply with a restricted rising and falling time

##### ■ Meaning of each parameter

The example shows the case where the amplitude range is  $\pm FS$ .

- Phase at start completion (OnPhase)

The original sine wave starts from this phase.

Variable range:  $0.00^\circ$  to  $360.00^\circ$

- Starting slope time (SlopeT)

The linear change in time of the amplitude from the zero to the amplitude at the start completion phase.

Variable range: 0.00% to 50.00 % of basic cycle

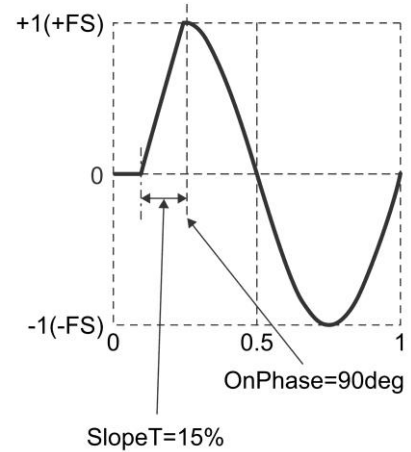

The amplitude of the original Sine wave is fixed at  $\pm FS$ .

Please note that the amplitude may be less than  $\pm FS$  depending on the value of the start completion phase.

##### ■ Waveform examples

The polarity and amplitude range are all Normal,  $\pm FS$ .

OnPhase=90 SlopeT=10	OnPhase=120 SlopeT=20	OnPhase=150 SlopeT=20	OnPhase=270 SlopeT=10

**b) Off-Ph Ctrl Sine**

■ Overview

Sine wave which follows a slope during shut off.

Application examples

- Simulates the output waveform of an AC power supply with a restricted rising and falling time

■ Meaning of each parameter

The example shows the case where the amplitude range is  $\pm FS$ .

- Shut off start phase (OffPhase)

The original sine wave ends at this phase.

Variable range:  $0.00^\circ$  to  $360.00^\circ$

- Shut off slope time (SlopeT)

The linear change in time of the amplitude from the amplitude of the shut down start phase to the zero.

Variable range: 0.00 % to 50.00 % of basic cycle

The amplitude of the original Sine wave is fixed at  $\pm FS$ .

Please note that the amplitude may be less than  $\pm FS$

depending on the value of the shut down start phase.

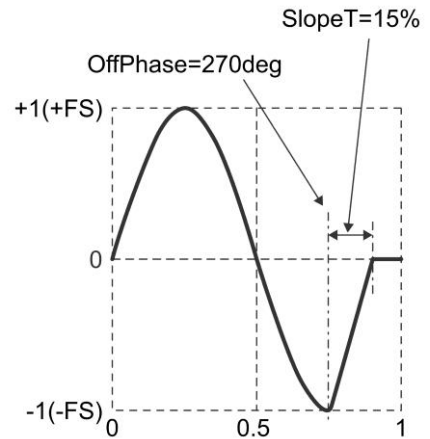

■ Waveform examples

The polarity and amplitude range are all Normal,  $\pm FS$ .

OffPhase=90 SlopeT=10	OffPhase=210 SlopeT=20	OffPhase=240 SlopeT=20	OffPhase=270 SlopeT=10

**c) Chattering-On Sine**

■ Overview

Sine wave which have a chattering pattern during the starting state.

Application examples

- Simulates an AC power supply output waveform which follows the chattering pattern of a switch or relay during the start of output.

■ Meaning of each parameter

The example shows the case where the amplitude range is  $\pm FS$ .

• On start phase (OnPhase)

The original sine wave begins to follow a chattering pattern from this phase.

It is fixed at zero before that.

Variable range:  $0.00^\circ$  to  $360.00^\circ$

• Number of chattering (ChatterN)

The number of times it repeatedly turns on and off. The repeated on and off portions have the same time duration.

Variable range: 0 to 3

• Time On (Ton)

The amount of time one chatter is turned on.

Variable range: 0.00% to 20.00% of basic cycle

• Time Off (Toff)

The amount of time one chatter is turned off.

Variable range: 0.00% to 20.00% of basic cycle

The amplitude of the original Sine wave is fixed at  $\pm FS$ . Please note that the amplitude may be less than  $\pm FS$  depending on each parameter setting.

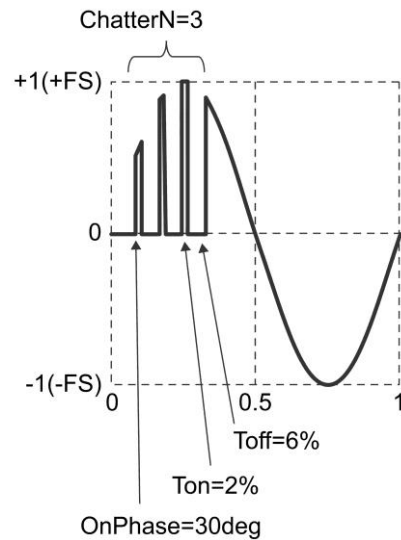

■ Waveform examples

The polarity and amplitude range are all Normal,  $\pm FS$

OnPhase=30 ChatterN=0 Ton=2 Toff=6	OnPhase=30 ChatterN=1 Ton=2 Toff=6	OnPhase=30 ChatterN=2 Ton=2 Toff=6	OnPhase=30 ChatterN=3 Ton=2 Toff=6

**d) Chattering-Off Sine**

■ Overview

Sine wave which have a chattering pattern during the shut off state.

Application examples

- Simulates an AC power supply output waveform which follows the chattering pattern of a switch or relay during output shut off.

■ Meaning of each parameter

The example shows the case where the amplitude range is  $\pm FS$ .

- Shut off start phase (OffPhase)

The original sine wave begins to follow a chattering pattern from this phase as it shuts off.

Variable range:  $0.00^\circ$  to  $360.00^\circ$

- Number of chattering instances (ChatterN)

The number of times it repeatedly turns off and on.

The repeated on and off portions have the same time duration.

Variable range: 0 to 3

- Time On (Ton)

The amount of time one chatter is turned on.

Variable range: 0.00% to 20.00% of basic cycle

- Time Off (Toff)

The amount of time one chatter is turned off.

Variable range: 0.00% to 20.00% of basic cycle

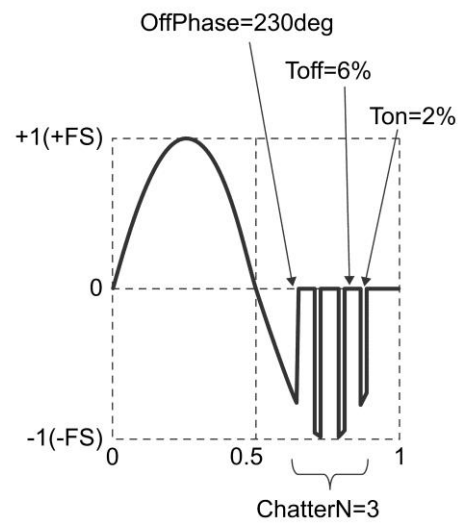

The amplitude of the original Sine wave is fixed at  $\pm FS$ . Please note that the amplitude may be less than  $\pm FS$  depending on each parameter setting.

■ Waveform examples

The polarity and amplitude range are all Normal,  $\pm FS$ .

OffPhase=230 ChatterN=0 Ton=2 Toff=6	OffPhase=230 ChatterN=1 Ton=2 Toff=6	OffPhase=230 ChatterN=2 Ton=2 Toff=6	OffPhase=230 ChatterN=3 Ton=2 Toff=6

### 6.2.4 Pulse Group

#### a) Gaussian Pulse

■ Overview

Waveform with a Gaussian distribution.

■ Meaning of each parameter

The example shows the case where the amplitude range is 0/+FS.

• Standard deviation (Sigma)

Gaussian sigma function.

Variable range: 0.01% to 100.00% of basic cycle standard

Peak value is fixed at +FS at the center of the horizontal axis.

The head and tail do not go to zero. Please note that the greater the standard deviation the more the head and tail will float above the zero level. The head will be less than 0.01•FS when the standard deviation is less than 16.47%.

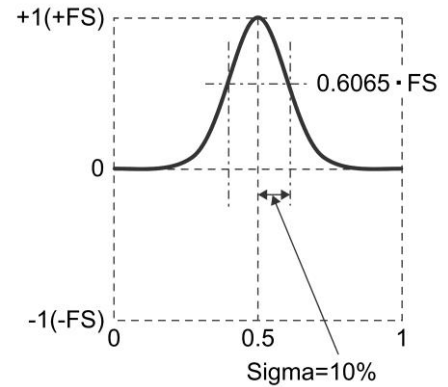

■ Waveform examples

The polarity and amplitude range are all Normal, 0/+FS.

Sigma=5	Sigma=10	Sigma=15	Sigma=20

■ Remarks

The half value width is  $2 \cdot \text{Sigma} \sqrt{2 \cdot \ln(2)} \approx 2.35 \cdot \text{Sigma}$

The following formula expresses x as the horizontal axis and y as the vertical axis (when the amplitude range is 0/+FS).

$$y = FS \cdot \exp\left(-\frac{1}{2} \left(\frac{100}{\text{Sigma}} (x - 0.5)\right)^2\right)$$

**b) Lorentz Pulse**

■ Overview

A Lorentz waveform.

■ Meaning of each parameter

The example shows the case where the amplitude range is 0/+FS.

• Half Width

The half value width of the Lorentz function.

Variable range: 0.01% to 100.00% of basic cycle

Peak value is fixed at +FS at the center of the horizontal axis.

The head and tail do not go to zero. Please note that the greater the half value width the more the head and tail will float above the zero level. The head will be less than  $0.01 \cdot FS$  when the half value width is less than 10.05%.

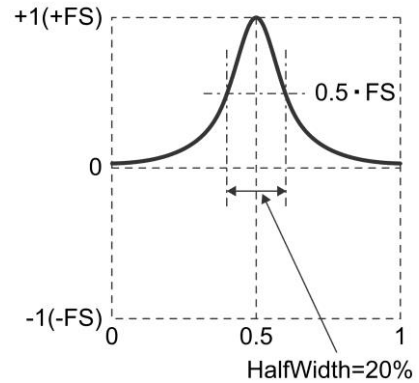

■ Waveform examples

The polarity and amplitude range are all Normal, 0/+FS.

HalfWidth=5	HalfWidth=10	HalfWidth=15	HalfWidth=20

■ Remarks

The following formula expresses x as the horizontal axis and y as the vertical axis (when the amplitude range is 0/+FS).

$$y = FS \frac{1}{1 + \left( \frac{200}{HalfWidth} (x - 0.5) \right)^2}$$

**c) Haversine**

■ Overview

Sin<sup>2</sup> pulse. Sine wave with an added offset from the -90° to 270° range.

■ Meaning of each parameter

The example shows the case where the amplitude range is 0/+FS.

• Width

The width of one cycle of the sine wave over the -90° to 270° range.

Other ranges are fixed at the zero level.

Variable range: 0.01% to 100.00% of basic cycle

Peak value is fixed at +FS at the center of the horizontal axis.

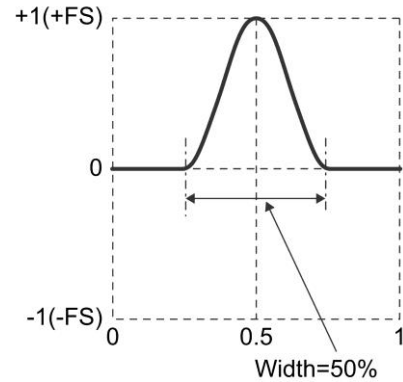

■ Waveform examples

The polarity and amplitude range are all Normal, 0/+FS.

Width=10	Width=20	Width=50	Width=100

■ Remarks

The half value width is Width/2(%).

The following formula expresses x as the horizontal axis and y as the vertical axis (when the amplitude range is 0/+FS).

In the range where x is  $0.5 \pm \frac{Width}{200}$

$$y = \frac{FS}{2} \left( 1 + \cos \left( 2\pi \frac{100}{Width} (x - 0.5) \right) \right)$$



**d) Half-Sine Pulse**

■ Overview

A sine wave half cycle pulse. A half cycle waveform of a sine wave from the 0° to 180° range.

■ Meaning of each parameter

The example shows the case where the amplitude range is 0/+FS.

• Width

The width of a sine wave from the 0° to 180° range.

Other ranges are fixed at the zero level.

Variable range: 0.01% to 100.00% of basic cycle

Peak value is fixed at +FS at the center of the horizontal axis.

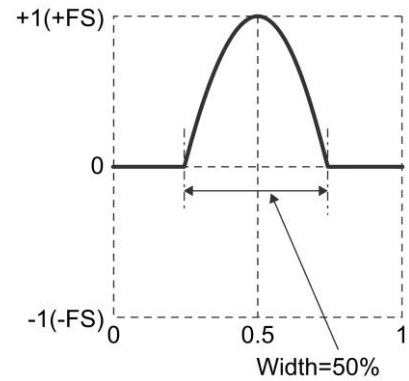

■ Waveform examples

The polarity and amplitude range are all Normal, 0/+FS.

Width=10	Width=20	Width=50	Width=100

■ Remarks

The half value width is  $2 \cdot \text{Width} / 3$  (%).

The following formula expresses x as the horizontal axis and y as the vertical axis (when the amplitude range is 0/+FS).

In the range where x is  $0.5 \pm \frac{\text{Width}}{200}$

$$y = FS \cdot \cos\left(\pi \frac{100}{\text{Width}} (x - 0.5)\right)$$

**e) Trapezoid Pulse**

■ Overview

A trapezoid waveform pulse.

■ Meaning of each parameter

The example shows the case where the amplitude range is 0/+FS.

• Slope width (RiseFall)

The width of each oblique side.

Variable range: 0.00% to 50.00% of basic cycle

• Upper base width (UpperBase)

The width of the upper base.

Variable range: 0.00% to 100.00% of basic cycle

Peak value is fixed at +FS at the upper base of the center of the horizontal axis.

Please note that the head and tail will be greater than zero when the sum of double the slope width and the upper base width exceeds 100%.

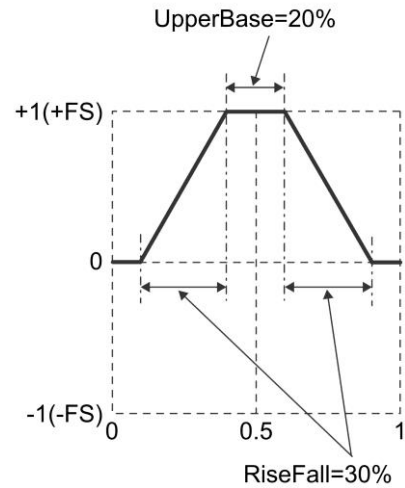

■ Waveform examples

The polarity and amplitude range are all Normal, 0/+FS.

RiseFall=25 UpperBase=50	RiseFall=20 UpperBase=20	RiseFall=0 UpperBase=20	RiseFall=20 UpperBase=0

**f) Sin(x)/x**

■ Overview

Sin(x)/x waveform. This is called the sinc function.

■ Meaning of each parameter

The example shows the case where the amplitude range is ±FS.

• Number of zero crossings (ZeroCross)

The number of zero crossings on one side.

Variable range: 1 to 50

Peak value is fixed at +FS at the center of the horizontal axis.

Has a frequency band that is roughly fundamental frequency times number of zero crossings.

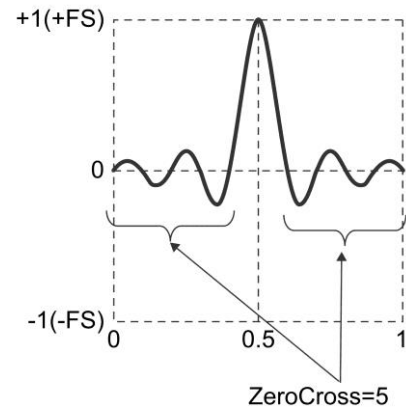

■ Waveform examples

The polarity and amplitude range are all Normal, ±FS.

ZeroCross=2	ZeroCross=5	ZeroCross=10	ZeroCross=20

■ Remarks

The following formula expresses x as the horizontal axis and y as the vertical axis (when the amplitude range is ±FS).

$$y = FS \cdot \frac{\sin(2\pi \cdot ZeroCross \cdot (x - 0.5))}{2\pi \cdot ZeroCross \cdot (x - 0.5)}$$

## 6.2.5 Transient Response Group

### a) Exponential Rise

#### ■ Overview

A first order LPF step response waveform.

Application examples

- Simulates a first order system's step output waveform

#### ■ Meaning of each parameter

The example shows the case where the amplitude range is  $0/+FS$ .

$0/+FS$ .

- Time constant (TC)

Time constant of the exponential function.

Variable range: 0.01% to 100.00% of basic cycle

The amplitude at infinite time is  $+FS$ . The tail will not rise to  $+FS$ . Please note that the tail value will get smaller as the time constant increases. The tail will be greater than  $0.99 \cdot FS$  when the time constant is less than 21.71%.

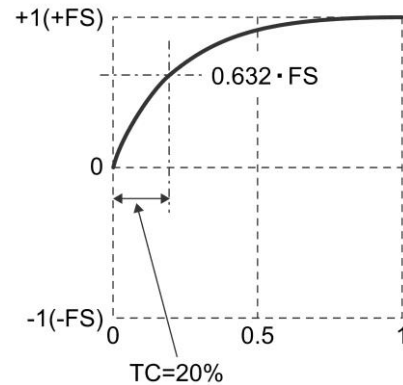

#### ■ Waveform examples

The polarity and amplitude range are all Normal,  $0/+FS$ .

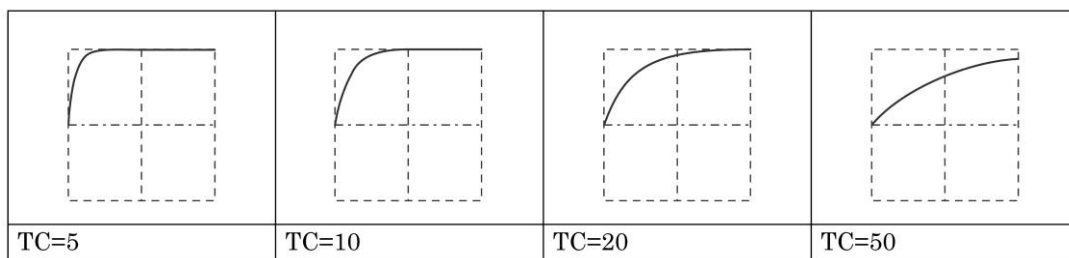

#### ■ Remarks

The following formula expresses  $x$  as the horizontal axis and  $y$  as the vertical axis (when the amplitude range is  $0/+FS$ ).

$$y = FS \cdot \left( 1 - \exp\left(-\frac{100}{TC} x\right) \right)$$

**b) Exponential Fall**

■ Overview

A first order HPF step response waveform.

Application examples

- Simulates a first order system's step output waveform

■ Meaning of each parameter

The example shows the case where the amplitude range is 0/+FS.

- Time constant (TC)

Time constant of the exponential function.

Variable range: 0.01% to 100.00% of basic cycle

The head starts at +FS, but the tail does not go to zero.

Please note that the tail offset will get larger as the time constant increases. The tail will be less than 0.01•FS when the time constant is less than 21.71%.

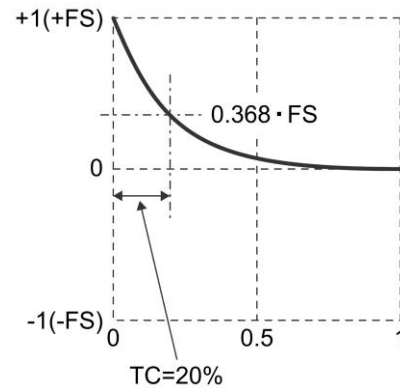

■ Waveform examples

The polarity and amplitude range are all Normal, 0/+FS.

TC=5	TC=10	TC=20	TC=50

■ Remarks

The following formula expresses x as the horizontal axis and y as the vertical axis (when the amplitude range is 0/+FS).

$$y = FS \cdot \exp\left(-\frac{100}{TC} x\right)$$

**c) 2nd Order LPF Step Response**

■ Overview

A second order LPF step response waveform.

Application examples

- Simulates the step output waveform of a transmission system accompanied by ringing and overshooting

■ Meaning of each parameter

The example shows the case where the amplitude range is 0/+FS.

- Natural frequency of the LPF (Fn)

The frequency of the oscillation component is lower than Fn.

Variable range: 1.00 to 50.00 times fundamental frequency

- LPF Q (Q)

The oscillation component will disappear when the Q is 0.5.

Variable range: 0.50 to 50.00

The amplitude at infinite time is FS/2. The peak value is less than +FS.

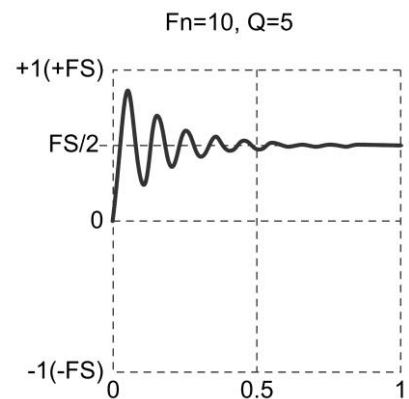

■ Waveform examples

The polarity and amplitude range are all Normal, 0/+FS.

Fn=5 Q=0.5	Fn=5 Q=1	Fn=10 Q=5	Fn=15 Q=20

■ Remarks

The oscillation frequency is expressed in the following formula (fundamental frequency standard).

$$Fn \cdot \sqrt{1 - \frac{1}{4 \cdot Q^2}}$$

**d) Damped Oscillation**

■ Overview

An oscillation waveform where the oscillation attenuates in the exponential fall. An oscillation waveform where the oscillation increases in the exponential rise can also be created.

Application examples

- Simulates a pulse response waveform accompanying an oscillation.

■ Meaning of each parameter

The example shows the case where the amplitude range is  $\pm FS$ .

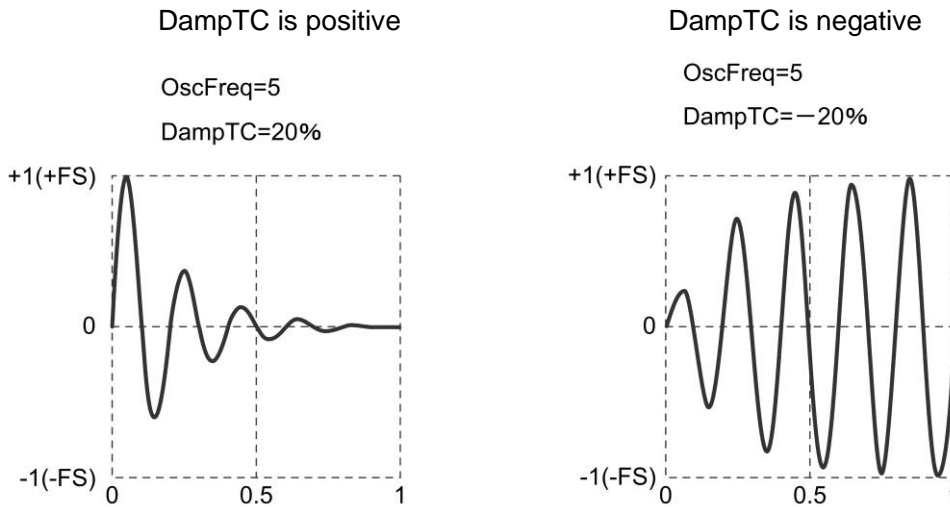

- Oscillation frequency (OscFreq)

Variable range: 0.01 to 50.00 times fundamental frequency

- Damped oscillation time constant (DampTC)

The oscillation exponentially attenuates by this time constant when positive.

The oscillation exponentially increases by this time constant when negative.

Variable range: -100.00% to 100.00% of basic cycle

The peak value is fixed at +FS when the damped oscillation time constant is positive.

The oscillation is  $\pm FS$  over infinite time when the damped oscillation time constant is negative.

■ Waveform examples

The polarity and amplitude range are all Normal,  $\pm FS$ .

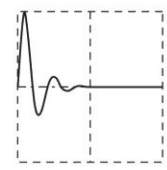
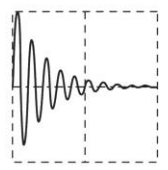
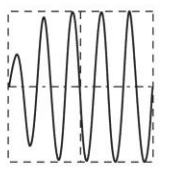
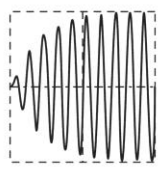
			
OscFreq=5 DampTC=10	OscFreq=10 DampTC=20	OscFreq=5 DampTC=-10	OscFreq=10 DampTC=-20

### 6.2.6 Surge Group

#### a) Oscillation Surge

##### ■ Overview

Simulates a surge waveform accompanying a damped oscillation.

The step response waveform of a cascade connection circuit with a first order HPF and a second order LPF.

Application examples

- Simulates a surge waveform superimposed on a power supply
- Simulates the rush current waveform of a power supply

##### ■ Meaning of each parameter

The example shows the case where the amplitude range is  $\pm FS$ .

- Oscillation frequency (OscFreq)

Variable range: 0.01 to 50.00 times fundamental frequency

- Damped oscillation time constant (DampTC)

The amplitude of the oscillation component exponentially attenuates by this time constant.

Variable range: 0.01% to 100.00% of basic cycle

- Trailing time constant (TrailTC)

Damping time constant of the waveform without the oscillation component (first order HPF time constant).

Variable range: 0.01% to 100.00% of basic cycle

Peak value is fixed at  $+FS$ . Please note that the amplitude also oscillates in the minus direction.

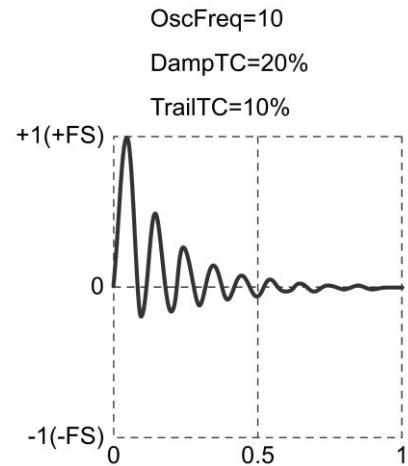

##### ■ Waveform examples

The polarity and amplitude range are all Normal,  $\pm FS$ .

OscFreq=10 DampTC=20 TrailTC=5	OscFreq=10 DampTC=20 TrailTC=30	OscFreq=10 DampTC=5 TrailTC=20	OscFreq=10 DampTC=30 TrailTC=20



**b) Pulse Surge**

■ Overview

Simulates a surge waveform. Does not have an oscillation component.

Application examples

- Simulates the transient voltage waveform of a car battery

■ Meaning of each parameter

The example shows the case where the amplitude range is 0/+FS.

- Rising time (Tr)

Time for the amplitude to rise from 10% to 90% of the peak value.

Variable range: 0.01% to 100.00% of basic cycle

- Time duration (Td)

Pulse width with an amplitude 10% or greater of the peak value.

Variable range: 0.01% to 100.00% of basic cycle

Peak value is fixed at +FS.

The tail does not go to zero. Please note that the greater the time duration the more the tail will float above the zero level.

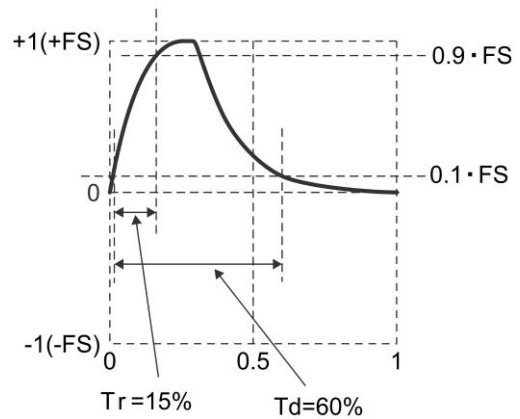

■ Waveform examples

The polarity and amplitude range are all Normal, 0/+FS.

Tr=1 Td=20	Tr=20 Td=50	Tr=5 Td=30	Tr=5 Td=80

■ Remarks

The prescribed waveform will not be created unless the condition that approx.  $1.839 < Td / Tr$  is satisfied.

### 6.2.7 Other Waveforms Group (Others Group)

#### a) Trapezoid with Offset

##### ■ Overview

A trapezoid wave with an offset in the amplitude direction.

Application examples

- Simulates the various voltages and current waveforms of a switching power supply circuit

##### ■ Meaning of each parameter

The example shows the case where the amplitude range is 0/+FS.

##### • Leading delay (Delay)

The rising start position of the trapezoid wave.

Variable range: 0.00% to 100.00% of basic cycle

##### • Rising slope width (Rise)

The width of the rising portion.

Variable range: 0.00% to 100.00% of basic cycle

##### • Upper base width (UpperBase)

The width of the upper base.

Variable range: 0.00% to 100.00% of basic cycle

##### • Falling slope width (Fall)

The width of the falling portion.

Variable range: 0.00% to 100.00% of basic cycle

##### • Offset

The amplitude direction offset of the entire trapezoid. Variable range: 0.00% to 100.00%

The peak value is fixed at +FS for the upper base.

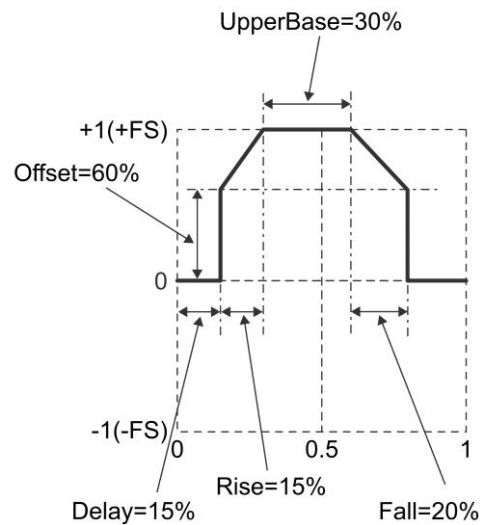

##### ■ Waveform examples

The polarity and amplitude range are all Normal, 0/+FS.

Delay=15 Rise=10 UpperBase=20 Fall=30 Offset=0	Delay=15 Rise=40 UpperBase=0 Fall=0 Offset=60	Delay=15 Rise=0 UpperBase=20 Fall=30 Offset=0	Delay=20 Rise=40 UpperBase=0 Fall=0 Offset=0

**b) Half-Sine Edge Pulse**

■ Overview

Pulse wave with variable rising time, falling time and pulse width duty.

The rising and falling shapes have the same half sine (half cycle of a sine wave) shape as a standard pulse wave. Because a standard pulse wave cannot be used in sequence oscillation, this wave is read into arbitrary waveforms and used instead.

■ Meaning of each parameter

The example shows the case where the amplitude range is 0/+FS.

• Leading time (LE)

Time for the amplitude to change from 10% to 90% of the peak value.

Variable range: 0.00% to 100.00% of basic cycle

• Trailing time (TE)

Time for the amplitude to change from 90% to 10% of the peak value.

Variable range: 0.00% to 100.00% of basic cycle

• Duty (Duty)

Pulse width duty with an amplitude 50% or greater of the peak value.

Variable range: 0.00% to 100.00%

Peak value is fixed at +FS.

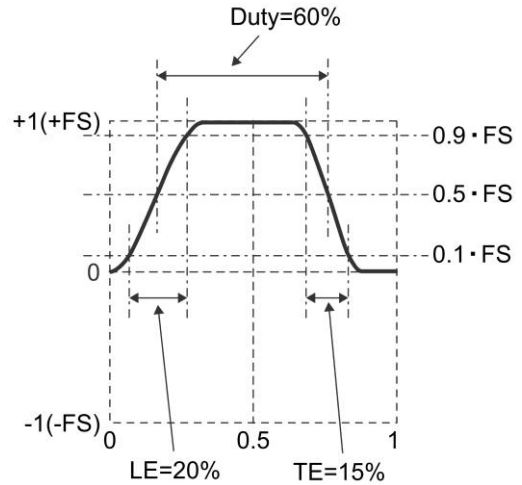

■ Waveform examples

The polarity and amplitude range are all Normal, 0/+FS.

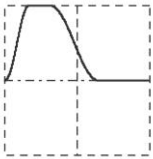
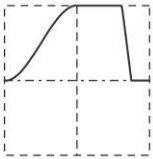
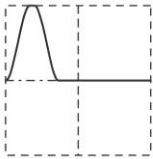
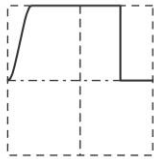
			
LE=10 TE=20 Duty=40	LE=30 TE=5 Duty=60	LE=10 TE=10 Duty=20	LE=10 TE=0 Duty=70

■ Remarks

The prescribed waveform will not be created unless the following formula is satisfied.

$$0.85 (LE + TE) \leq \text{Duty} \leq 100 - 0.85 (LE + TE)$$

**c) Bottom Referenced Ramp**

■ Overview

Ramp wave referenced to the bottom level.

■ Meaning of each parameter

The example shows the case where the amplitude range is 0/+FS.

• Symmetry (Symm)

The ratio of the rising portion.

Variable range: 0.00% to 100.00%

Peak value is fixed at +FS.

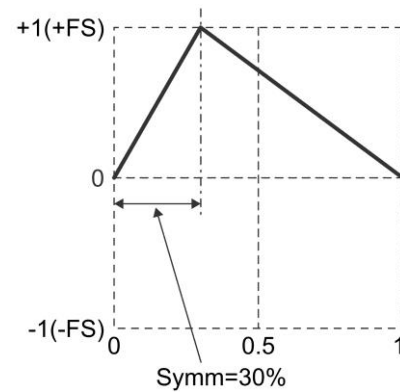

■ Waveform examples

The polarity and amplitude range are all Normal, 0/+FS.

Symm=0	Symm=50	Symm=80	Symm=100

■ Remarks

The zero phase degree is fixed at the bottom level except when the symmetry is 0%.

In a standard ramp wave, the zero phase degree is fixed at the amplitude's center zero point.

☞ P.4-49

## 7. Creating Arbitrary Waveforms

7.1	Basics .....	7-2
7.2	Display Procedure and Overview of Screen for Creating/Editing Arbitrary Waveforms.....	7-3
7.3	Creating New Arbitrary Waveform.....	7-5
7.4	Simple Arbitrary Waveform Creating Example .....	7-6
7.5	Outputting Created Arbitrary Waveform .....	7-7
7.6	Saving Created Arbitrary Waveform.....	7-7
7.7	To Use the Saved Arbitrary Waveform .....	7-9
7.8	To Delete the Saved Arbitrary Waveform .....	7-12
7.9	Identifying Memory Space Required for Saving Arbitrary Waveforms .....	7-13

## 7.1 Basics

There are the following two types of methods to create arbitrary waveforms:

- Enter waveform data from the panel.
- Use the accompanying arbitrary waveform editing software to create arbitrary waveforms on a personal computer.

This section describes the method to create arbitrary waveforms using operations on the panel of the main unit.

Before doing it, you must understand some of arbitrary waveforms of this product.

### ■ Two types of data formats

There are the following two types of data formats for the arbitrary waveform data of this product:

- Array format
  - The data sequence corresponding to the address of a waveform memory.
  - This is the data format for using a waveform acquired with an oscilloscope as an arbitrary waveform.
  - Waveforms imported by the digital oscilloscope can be transferred to this product using the accompanying arbitrary waveform editing software.
  - Array format data cannot be created or edited on the panel. Also cannot be copied to edit memory.
  - Waveform length of the array format is 4Ki- to 1Mi words ( $2^n$ ,  $n = 12$  to  $20$ ).
- Control point format
  - A waveform is created by interpolating between the specified control points (control points) with a straight line.
  - Data value for each memory address cannot be specified directly.
  - A relatively simple arbitrary waveform can be created or edited manually on the panel.
  - The number of control points in the control point format can be 2 to 10,000 points.
  - For a waveform to be created, its time axis direction is fixed to 0 to 1 per cycle and the amplitude direction is fixed to  $\pm 1$  (equivalent to  $\pm FS$  of waveform memory).

### ■ Save location of arbitrary waveforms

There are the three following save locations for arbitrary waveform data. Each memory is shared by two channels in the WF1968.

- Internal storage memory
  - Non-volatile memory to save arbitrary waveforms.
  - The non-volatile memory can save up to 128 arbitrary waveforms for a total of 4Mi words (8Mi bytes).
  - It can save arbitrary waveform data in any of array and control point formats.
  - For the memory capacity required for saving, [☞ P.7-13](#)
- Edit memory
  - Volatile memory to create an arbitrary waveform in the control point format. You can change the number of control points between 2 and 10,000 points.
  - When you create/edit an arbitrary waveform on the panel, you operate data on this edit memory.
  - Only one waveform can be treated on the edit memory.
  - It is not possible to copy an array format of waveform in the edit memory.
- External USB flash memory
  - Allows you to copy data between the internal storage memory or edit memory reciprocally.
  - Arbitrary waveforms stored here cannot be directly output or directly edited. In order to edit or output, please copy once the edit memory or internal memory.

### ■ Selection of arbitrary waveforms to be output

If you set an arbitrary waveform as an output waveform in the Oscillator setting screen, you can select from internal memory or the edit memory.

The selected waveform is written to the output waveform memory with a maximum 1Mi word length. If you select an output waveform on the edit memory, a waveform you are creating/editing appears as it is in the output.

## 7.2 Display Procedure and Overview of Screen for Creating/Editing Arbitrary Waveforms

An arbitrary waveform is created or edited in the ARB Edit screen.



Select [ARB Edit]

1. Pressing the MENU key opens the top menu. Then, select [ARB Edit] and press the ENTER key. This opens the ARB Edit screen.

2. The ARB Edit screen has two types of display formats.

They are a list display, which displays values side by side, and a graph display. You can switch between displays using the tabs on the far left of the screen.

[Index] shows the number of control points, beginning with zero (0). Start point is fixed to X = 0.000000. End point is fixed to X = 1.000000, and the paired Y values of both the start and end points are the same. (the same point).

If an output waveform is set to the arbitrary waveform in the edit memory, the waveform being created appears as is in the output. If the output waveform is set to other waveform, when you select the [Apply] button and press the ENTER key, the setting of output waveform is changed to the arbitrary waveform in the edit memory, and the waveform being created appears in the output.

### ■ List display

For the list display, a waveform in process of creation and a list of control points are displayed. A shape of waveform is created by setting X and Y values for each control point.

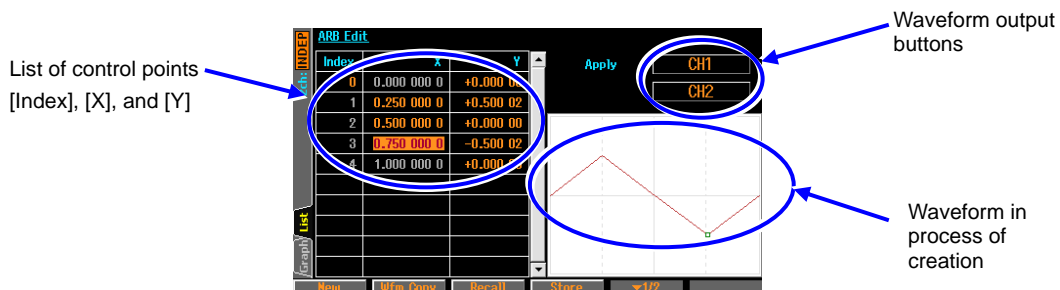

List of control points [Index], [X], and [Y]

Waveform output buttons

Waveform in process of creation

■ **Graph display**

For the graph display, a waveform in process of creation is enlarged. X and Y values of the one selected control point are displayed. As with the list display, the shape of the waveform is created by setting the X and Y values for each control point. You can enlarge a waveform display both horizontally and vertically with a focus on the selected control point.

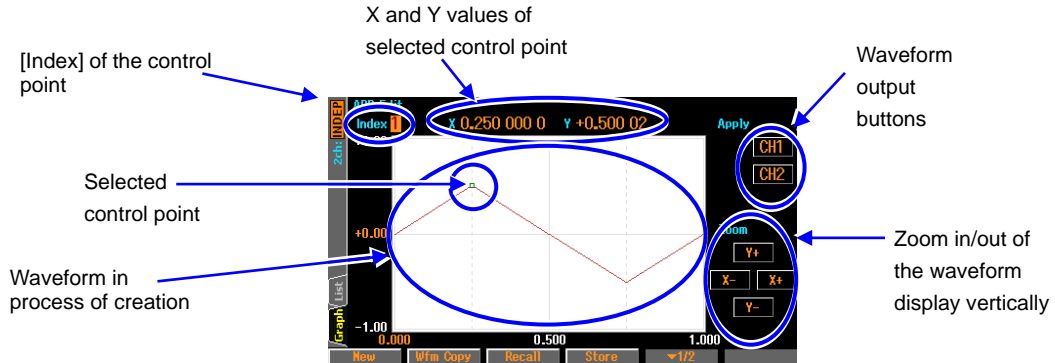

■ **Soft-keys**

First row ([ ▼ 1/2] appears to the right side)



[New]: Clears the edit memory and initializes its state.

[Wfm Copy]: Copies a standard waveform in to the edit memory.

[Recall]: Copies the already saved arbitrary waveform in the control point format to the edit memory.

[Store]: Saves the waveform in the edit memory.

Second row ([ ▼ 2/2] appears to the right side)



[Index -1]: Decrements the value of [Index] by one.

[Index +1]: Increments the value of [Index] by one.

[Delete]: Deletes the selected control point.

[Insert]: Inserts a new control point between the selected control point and the control point just before the selected point



## 7.3 Creating New Arbitrary Waveform

There are the following three types of methods to newly create an arbitrary waveform:

- Create a new arbitrary waveform thoroughly  
First, press the [New] soft-key to clear the edit memory. Then, enter control points. The next section describes the example of creation.
- Based on the standard waveform, modify it to create a new arbitrary waveform  
First, press the [Wfm Copy] soft-key to copy a standard waveform to the edit memory. Then, modify control points. How to operate control points is the same as the case of creating a new arbitrary waveform thoroughly.  
However, noise and DC of the standard waveform cannot be copied. Square and pulse waves are copied as ideal square waves that keep duty.
- Based on the saved arbitrary waveform, modify it to create a new arbitrary waveform  
First, press the [Recall] soft-key to copy the saved arbitrary waveform in the control point format onto the edit memory. Then, modify control points. How to operate control points is the same as the case of creating a new arbitrary waveform thoroughly.

## 7.4 Simple Arbitrary Waveform Creating Example

This section creates a simple arbitrary waveform actually. Use the list display to explain the example. Arbitrary waveform to create is a triangular wave as shown below. The number of control points of this waveform is three, but in this section, it begins with two points and then changes to three points on the way.

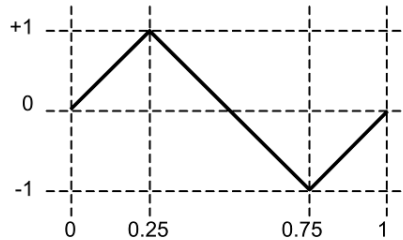

1. When the [New] soft key is pressed and the number of control points is set to 2, the results will be as follows:

Index	X	Y
0	0.000000	+0.000000
1	0.500000	+0.000000
2	1.000000	+0.000000

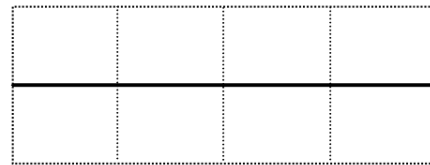

2. Change the setting of Index=1 to X=0.25, Y=+1.

Index	X	Y
0	0.000000	+0.000000
1	0.250000	+1.000000
2	1.000000	+0.000000

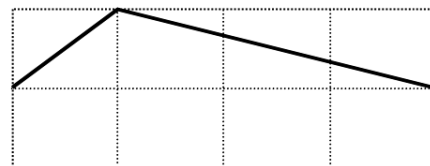

3. Select the Y value field of the end line (Index=2, X=1) and then press the [Insert] soft key. The control point with X=0.625000, Y=+0.49998 is newly created. The values rounded to 16-bit units are displayed as the Y values, assuming  $\pm 32767$  to be  $\pm 1$ .

Index	X	Y
0	0.000000	+0.000000
1	0.250000	+1.000000
2	0.625000	+0.49998
3	1.000000	+0.000000

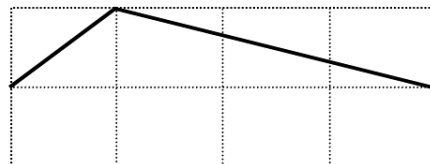

4. Change the setting of Index=2 to X=0.75 and Y=-1. This completes the procedure.

Index	X	Y
0	0.000000	+0.000000
1	0.250000	+1.000000
2	0.750000	-1.000000
3	1.000000	+0.000000

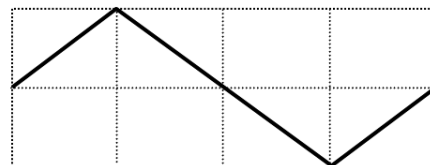

✓ Check

- The X value can be changed within a range between the control point just before the X value and the control point just after the X value.
- The Y value is rounded to 16-bit resolution.
- To change the Y value to the form of a step, set the variation width between adjacent X values to the minimum value, 0.000001.

## 7.5 Outputting Created Arbitrary Waveform

Select the [Apply] button (per CH for WF1968) on the screen, and then press the ENTER key. The waveform in process of creation is in the output.

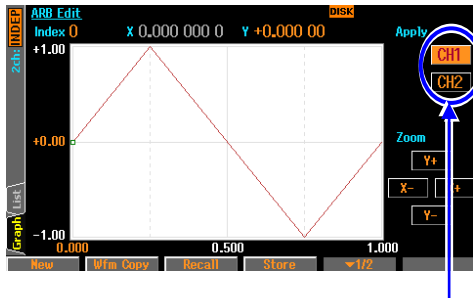

When you press the Apply button, waveform in process of creation is output .

## 7.6 Saving Created Arbitrary Waveform

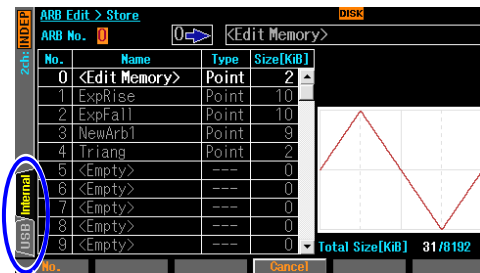

It indicates that which is activated internal memory or USB flash memory. Select the target, and press the ENTER key.

1. Pressing the [Store] soft-key switches to the save screen. The internal memory or USB flash memory may be selected as the save destination on this screen.
2. Select the [Internal] or [USB] tab on the far left of the screen and press ENTER to choose the save destination.

### 7.6.1 Saving to Internal Memory

Select the memory number of destination.

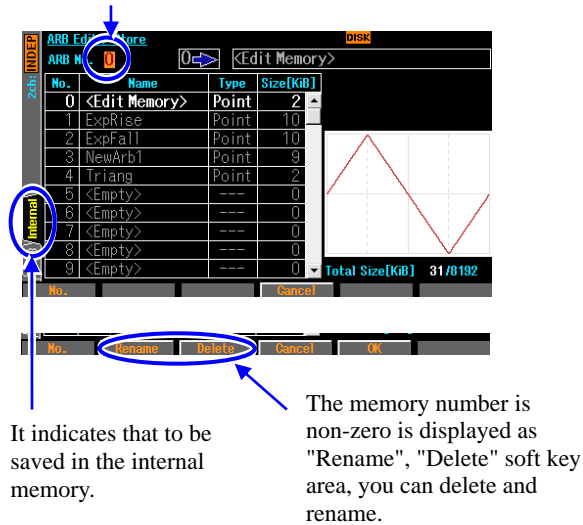

It indicates that to be saved in the internal memory.

The memory number is non-zero is displayed as "Rename", "Delete" soft key area, you can delete and rename.

1. In order to select the save source, display the first page. When USB is selected, press the ENTER key to select Internal.
2. Select an arbitrary memory number between 1 and 128 and select the [OK] soft-key. Saves the contents of the edit memory to the internal memory. You can name a waveform.
3. Select the [Delete] soft-key to delete the waveform memory contents or the [Rename] soft-key to change the name.

### 7.6.2 Saves to USB Flash Memory

The screens for saving an arbitrary waveform to USB flash memory are split into two pages. First screen specifies the save source (edit memory and internal arbitrary waveform memory) and second screen specifies the save destination (USB flash memory).

Press the Next soft-key to change screens. The currently displayed screen is indicated by the icon at the top center of the screen.

When USB interface is used, the USB flash memory is not available.

#### a) Selecting the save source, rename, delete

save source

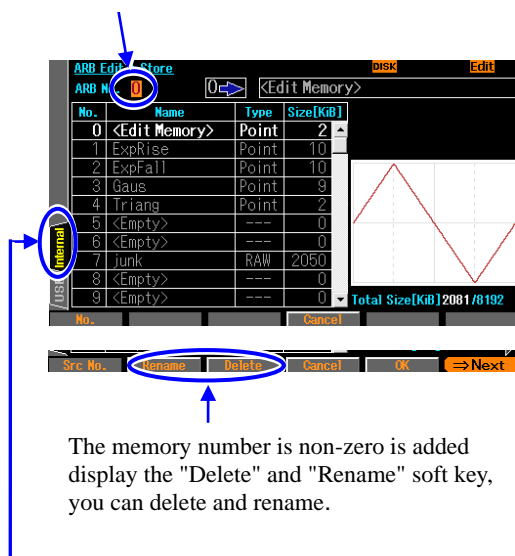

The memory number is non-zero is added display the "Delete" and "Rename" soft key, you can delete and rename.

Press the ENTER key to select the Internal tab to save source to edit memory.

1. In order to select the save source, display the first page. When the second page is displayed, press the ⇒Next soft keys at the bottom right of the screen.
2. Select the number 0 if you want to save the edit memory. Other number indicates that you want to save the source the body built-in memory. When you press the [OK] soft key, the dialog to specify the file name will appear. Enter a file name and press the [OK] soft key to save the arbitrary waveform to the current folder.
3. Select the [Delete] soft-key to delete the waveform memory contents or the [Rename] soft-key to change the name.

**b) Selecting the save destination, rename, delete**

This screen allows you to change the save destination folder, create a folder, delete files and folders, and rename items. Folders are displayed "/" at the end.

Press the [OK] soft-key when not selecting the folder to display the dialog for specifying the file name. Enter the file name and press the [OK] soft-key to save the arbitrary waveform from the save source in the current folder.

Pressing the [Enter] soft-key while selecting a folder sets the current folder to the specified folder (or "../" for the folder above).

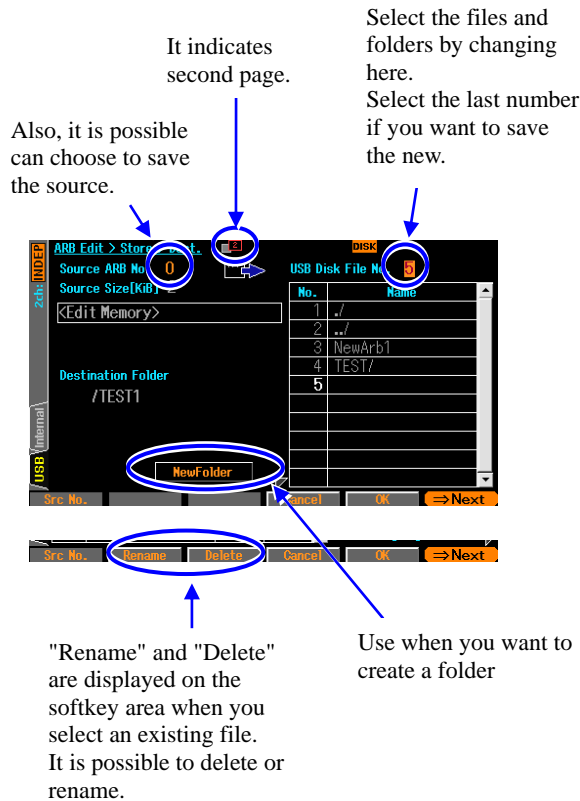

It indicates second page.

Also, it is possible can choose to save the source.

Select the files and folders by changing here.

Select the last number if you want to save the new.

1. In order to select the destination, display the second page. When the first page is displayed, press the ⇒ Next soft keys at the bottom right of the screen.
2. Select USB tab and press the ENTER key to select the bottom left of the screen.
3. Select the file number for destination in the top right corner of the screen.
4. Select the [Delete] soft-key to delete the waveform memory contents or the [Rename] soft-key to change the name.
5. When [Rename] soft key is pressed, a dialog box will appear. Change the name of the selected file/folder.

6. Select the "NewFolder" button and press the ENTER soft key, a dialog box will appear. Input folder name and press the [OK] soft key, the folder is created under the current folder, it will appear in the list of files.

**c) Time stamp of files**

WF1967/WF1968 does not have a built-in battery, will shift the time of the only time stamp minute of non-energized time. Time stamp of the file that you created in this instrument, is what the date and time that made the adjustment of the instrument is obtained by adding energizing time. It is not possible to change the date and time for the time stamp.

**7.7 To Use the Saved Arbitrary Waveform**

A waveform saved in the internal arbitrary waveform memory may be specified on the arbitrary waveform selection screen which appears with the [Select] button when selecting an arbitrary waveform on the Oscillator setting screen. P.4-53

To use an arbitrary waveform saved on USB flash memory, it must first be copied to edit memory or the internal arbitrary waveform memory. However, array format of waveform does not allow you to copy the edit memory. Pressing the [Recall] soft-key on the ARB Edit arbitrary waveform selection screen will switch to the recall screen. The internal memory or USB flash memory may be selected as the source on

this screen. Select the [Internal] or [USB] tab on the far left of the screen and press the ENTER key to switch sources.

Selection of either read from USB memory or internal memory.

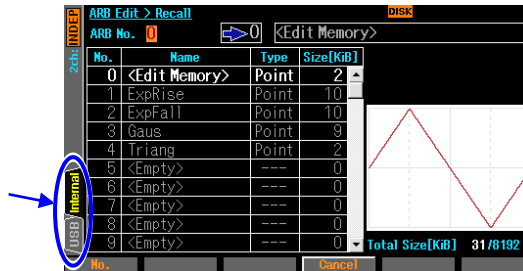

### 7.7.1 To Retrieve From Internal Memory

Select an arbitrary memory number between 1 and 128 and select the [OK] soft-key. The contents of the specified internal memory location are copied to the edit memory. The name can also be changed on this screen with the [Rename] soft-key.

Select source

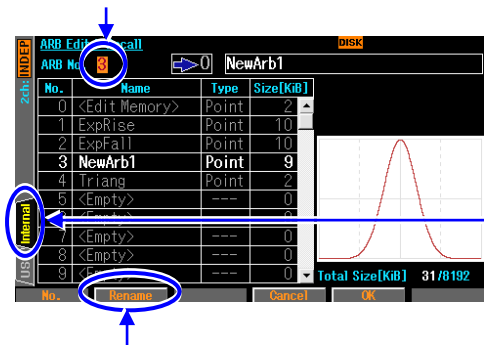

It indicates that it is read from the internal memory.

"Rename" is displayed in the soft key area, you can rename.

### 7.7.2 To Retrieve From USB Flash Memory

The screens for retrieving from USB flash memory are split into two pages. One screen specifies the retrieval source (files in USB flash memory) and the other the retrieval destination (edit memory or internal arbitrary waveform memory).

Press the Next soft-key to change screens. The currently displayed screen is indicated by the icon at the top center of the screen.

#### a) To select the retrieval source

This screen allows you to specify the file to be retrieved as well as change the current folder.

Pressing the [OK] soft-key while a file is selected retrieves the arbitrary waveform from the specified file and copies it to the edit memory or internal arbitrary waveform memory as specified on the next page.

Pressing the [Enter] soft-key while selecting a folder sets the current folder to the specified folder (or "../" for the folder above).

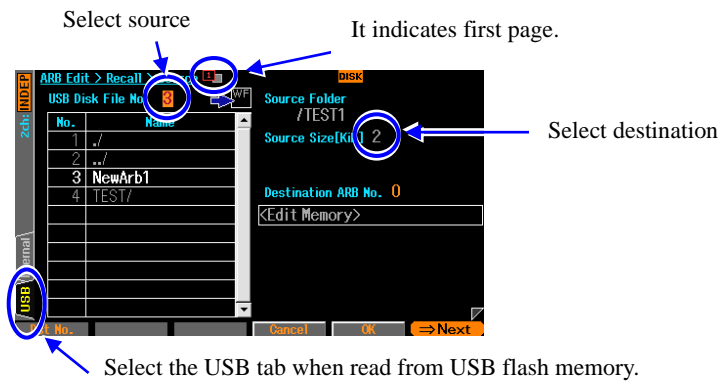

#### b) To select the retrieval destination

Select number 0 to copy to the edit memory. All other numbers specify an arbitrary waveform memory location on the device as the copy destination. Press the [OK] soft-key to copy the arbitrary waveform in the USB flash memory selected on the previous page to the specified destination. If the copy destination is the internal arbitrary waveform memory then the name will be the file name in USB flash memory.

If the selected internal arbitrary waveform memory is not <Empty>, then the file name may be changed with the [Rename] soft-key.

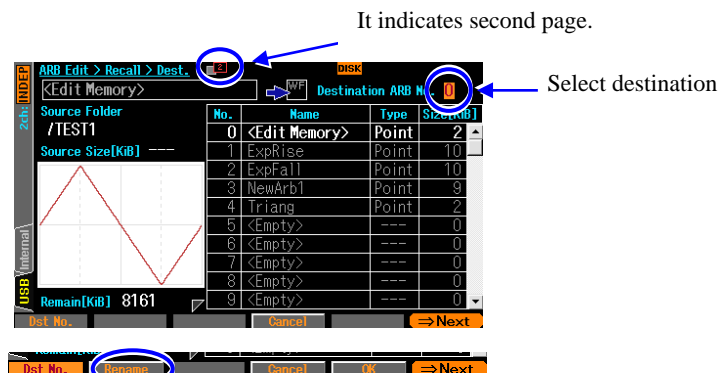

When you select an internal memory is not an Empty appears [Rename] soft key area, you can change the name.

## 7.8 To Delete the Saved Arbitrary Waveform

The upper limit of the storage capacity for the internal arbitrary waveform memory cannot be exceeded. In this case, unnecessary arbitrary waveforms must be deleted.

Select the [Store] soft-key on the ARB Edit screen to change to the save screen and delete any arbitrary waveforms.

### 7.8.1 To Delete From Internal Memory

Select the memory number and press the [Delete] soft-key. The contents of the specified internal memory location are deleted. The arbitrary waveform memory of a number used as a waveform cannot be deleted.

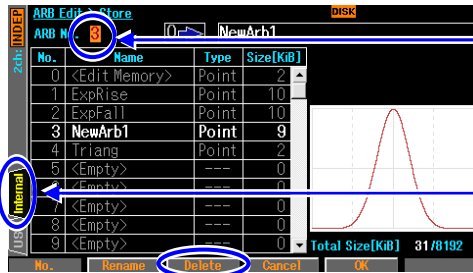

Select the number of you want to delete files.

Select the Internal tab to remove the internal memory file.

Finally press the Delete soft key.

### 7.8.2 To Delete From USB Flash Memory

The screens for saving an arbitrary waveform to USB flash memory are split into two pages. One screen specifies the save source (edit memory and internal arbitrary waveform memory) and the other the save destination (USB flash memory).

Press the Next soft-key to switch and display the save destination.

Select the USB flash memory file you wish to delete on this screen and press the [Delete] soft-key.

Press the [Next] soft key to display the second page.

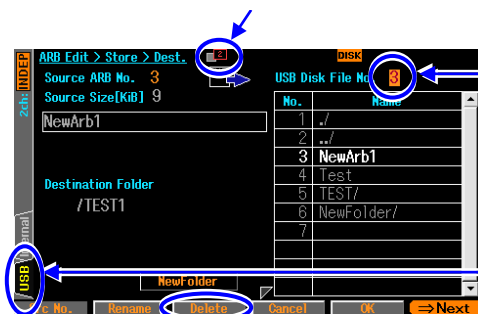

Specifies the number of you want to delete files

Select the USB tab and press the ENTER key.

Finally press the Delete soft key.



## 7.9 Identifying Memory Space Required for Saving Arbitrary Waveforms

The non-volatile memory can save arbitrary waveforms up to 128-waveforms or 4 Mi-words (8Mi bytes).

The memory capacity (K-byte) required when saving an arbitrary waveform in the array format and control point format, respectively is calculated by the following formula.

Array format:  $(2 \times \text{waveform length (word)} + 768) / 1024$  (rounding up the decimal point)

Control point format:  $(8 \times \text{the number of control points} + 768) / 1024$  (rounding up the decimal point)

The memory capacity required when saving an arbitrary waveform in the array format is shown in the following table:

Waveform size	4KiW	8KiW	16KiW	32KiW	64KiW	128KiW	256KiW	512KiW	1MiW
Memory capacity required for save	9KiB	17KiB	33KiB	65KiB	129KiB	257KiB	513KiB	1025KiB	2816KiB

The example of memory capacity required when saving an arbitrary waveform in the control point format is shown in the following table:

Number of control points	2	10	100	300	1,000	2,000	5,000	10,000
Memory capacity required for save	1KiB	1KiB	2KiB	4KiB	9KiB	17KiB	40KiB	79KiB

In the selection screen of the arbitrary waveform (common to both recall and save), the following items are displayed in addition to the waveform number, [No.], and waveform name, [Name].

- Data format [Type]: The waveforms in the array and control point formats are displayed as [RAW] and [Point], respectively. The edit memory with No.0 is displayed as [Point] because of the control point format.
- Save memory capacity [Size]: For arbitrary waveforms between No.1 and 128, the memory capacity used for saving is displayed in K-bytes. For the edit memory with No. 0, the memory capacity required if it is saved is displayed in K-bytes.
- Total save memory capacity [Total Size]: Total memory capacity currently used for saving arbitrary waveforms between No.1 and 128 is displayed in K-bytes. The size of edit memory with No.0 is excluded from the total capacity.

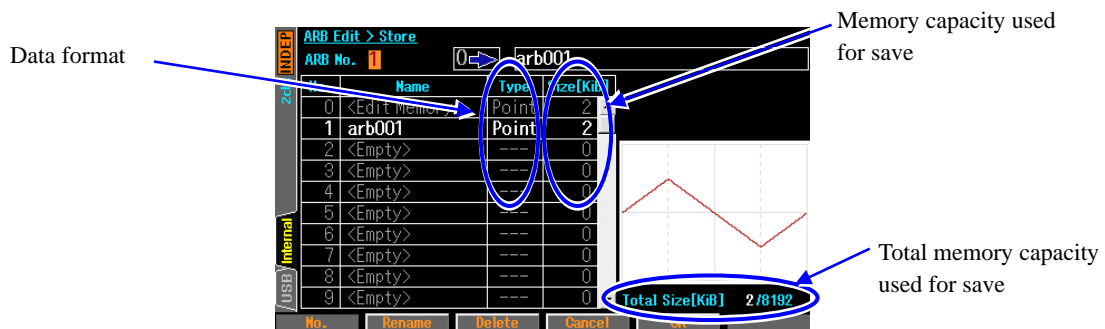

MEMO









## **8. Convenient Use of 2-channel Equipment (WF1968 Only)**

8.1	Outline .....	8-2
8.2	Copying Setting between Channels .....	8-3
8.3	Unifying Settings of 2 Channels .....	8-5
8.4	Phase Synchronization between Channels.....	8-6
8.5	Maintaining to Same Frequency (2-Channel Coordination, 2-Phase).....	8-7
8.6	Keeping Frequency Difference Constant (2-Channel Coordination, 2-Tone) .....	8-9
8.7	Keeping Frequency Ratio Constant (2-Channel Coordination, Ratio).....	8-11
8.8	Obtaining Differential Output (2-Channel Coordination, Differential).....	8-13
8.9	Obtaining Double Output Voltage(2-Channel Coordination, Differential 2).....	8-14

## 8.1 Outline

You can use 2-channel equipment, WF1968, not only as the two independent oscillators but also as the 2-channel coordination setting and operation.

Functions specific to 2-channel equipment are as follows:

- **Parameter copy function**  
One's channel setting can be copied to another's channel setting.  
Channel settings can be changed each other.  P.8-3
- **2-channel equivalence setting function**  
Various values such as the amplitude and DC offset can be set to the same values between two channels. Output on/off can be operated simultaneously between two channels.  P.8-5
- **Phase synchronization function**  
Oscillation phase for each channel can be initialized. This function is used for 2-channel independent operation with the continuous oscillation mode.  P.8-6
- **2-channel coordination operation: 2-phase function**  
The synchronization relationship with the same frequency can be kept. This function controls to keep the synchronization relationship with the same frequency also during the frequency modulation or frequency sweep.  P.8-7
- **2-channel coordination operation: function with constant frequency difference**  
The frequency can be changed with the frequency difference kept constant. This function controls to keep the frequency difference constant also during the frequency modulation or frequency sweep.  P.8-9
- **2-channel coordination operation: function with constant frequency ratio**  
The frequency can be changed with both the frequency ratio and synchronization relationship kept constant. This function controls to keep the frequency ratio constant also during the frequency modulation or frequency sweep.  P.8-11
- **2-channel coordination operation: differential output function**  
The reverse phase waveform can be output with the same frequency, amplitude, and DC offset. This function controls to keep the reverse phase waveform also during the frequency modulation or frequency sweep.  P.8-13
- **2-channel coordination operation: differential 2 function**  
The reverse phase waveform can be output with the same frequency and amplitude. In this mode, the polarity of DC offset is also reversed, which is different from the differential output function. Therefore, when the hot sides of CH1 and CH2 are used as the output, including DC, double output voltage can be obtained.  P.8-14

## 8.2 Copying Setting between Channels

Copying the settings between channels can be done on the Utility screen.

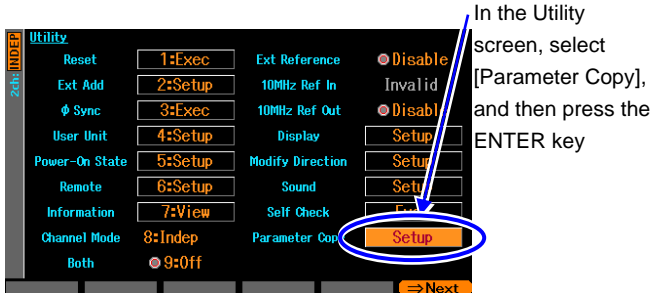

1. In the Utility screen, select [Parameter Copy] and then press the ENTER key.



2. After the Parameter copy window is opened, select the [Copy Direction] field, and then press the ENTER key. The selection list to show the copy direction is opened.

You can select a copy direction from the following three types: [CH1 →CH2] (CH1 to CH2 ), [CH2⇒CH1] (CH2 to CH1), and [CH1↔CH2] (exchange with each other between CH1 and CH2). Select a direction you want, and then

press the ENTER key.

3. Next, select a parameter type to copy.

To copy all parameters, select [All Parameters]. Otherwise, select parameters for each oscillation mode. There are the following four types of parameters as parameters for each oscillation modes: continuous oscillation mode parameters, [Basic Parameters], modulated oscillation mode parameters, [Modulation Parameters], sweep oscillation mode parameters, [Sweep Parameters], and burst oscillation mode parameters [Burst Parameters].

Select a parameter type you want and press the ENTER key, then the parameter type is set as the copy target and [Copy] is shown next to it. Press the ENTER key again, then the parameter type is excluded from the copy target and [Off] is shown next to it.

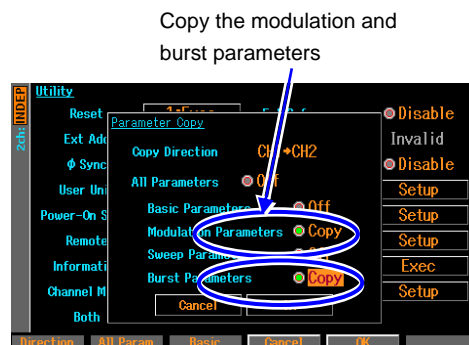

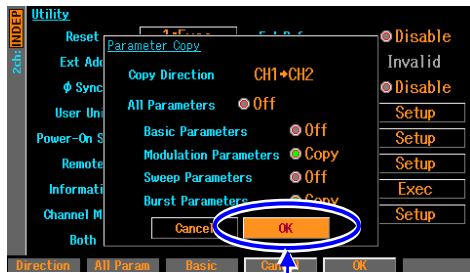

Select [OK] and then press the ENTER key to make a copy.

4. When the above setting is completed, select [OK] at the bottom of the window, and then press the ENTER key. The copy operation is performed. When you do not want to copy, select [Cancel] at the bottom of the window and press the ENTER key, or press the CANCEL key.

#### ■ Remarks

Copying all of [Basic Parameters], [Modulation Parameters], [Sweep Parameters], and [Burst Parameters] is not equivalent to copying [All Parameters].

The following items are copied only when copying [All Parameters]:

- Output on/off state
- Oscillation mode
- External addition setting
- User-defined unit
- Start-up output on/off setting
- Waveform parameters setting for all waveforms (for the copy of [Basic Parameters], the waveform parameters setting is copied only for the currently used waveforms at the copy source)
- Amplitude/DC offset setting or high level/low level setting

## 8.3 Unifying Settings of 2 Channels

### ■ Procedure and operation

First, set the 2-channel equivalence setting function to on in the Utility screen.

Next, set items to which you want to set the same setting. When you set setting for one channel, the same settings are set to the same items for another channel. In addition to the frequency, phase, amplitude, and DC offset, this is applied to the oscillation mode and waveforms. This is also applied to the output on/off, burst trigger, sweep start/stop operation.

This function is enabled until the 2-channel equivalence setting function is reset to off.

### ■ To turn on/off 2-channel equivalence setting function

Turning on/off 2-channel equivalence setting function is performed in the Utility screen.

In the Utility screen, select [Both], and then press the ENTER key to switch an indicator to [On] from [Off].

This turns 2-channel equivalence setting function on.

If you want to reset to [Off], press the ENTER key again.

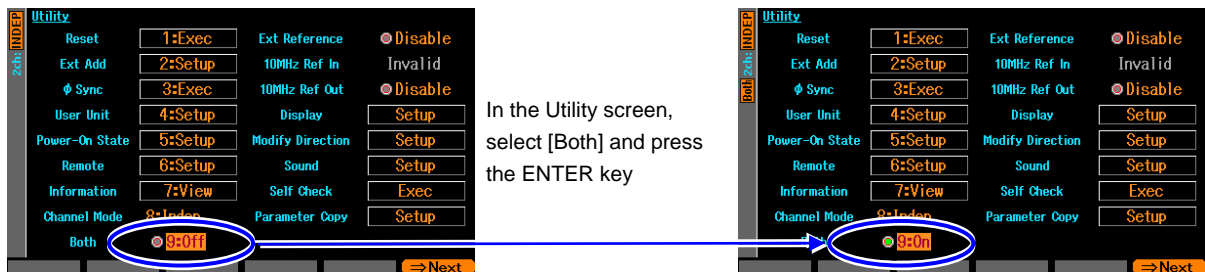

The [BOTH] indicator above the CH1/CH2 key is lit

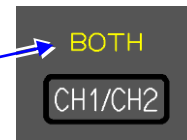

Other than in the Utility screen, you can switch on/off by holding down the CH1/CH2 key for 2 or more seconds.

## 8.4 Phase Synchronization between Channels

Even if you set the frequency and phase to the same values using the 2-channel equivalence setting function, the phase relationship between the output waveforms from the 2 channels is changed accordingly. To synchronize the phases, the phase synchronous operation is required. This synchronous operation is used for 2-channel independent operation (the channel mode setting is set to [Indep]).

If you want to always keep the same frequency or frequency ratio and need a phase synchronization state, use the 2-channel coordination function. [P.8-7, P.8-11](#)

For synchronization of multiple units, [P. 9-2](#)

### ■ Performing synchronization

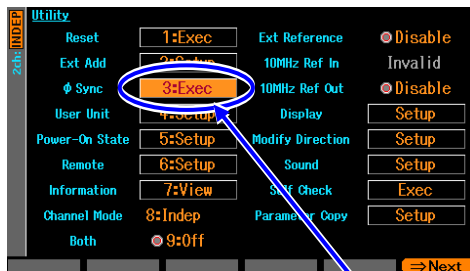

In the Utility screen, select [φSync] and then press the ENTER key to execute the phase synchronization

First, set the channel mode to [Indep] and set the frequency setting for both channels to the same value.

The synchronous operation is performed in the Utility screen.

Select [φSync] in the Utility screen, and then press the ENTER key.

This runs the phase synchronization.

At this time, the phase will be discontinuous temporarily because both channels stop the oscillation once.

### ■ Phase relationship after synchronous operation

The oscillation phase for each channel is initialized by the synchronous operation. The phase difference of the output waveform appears as the difference of the phase setting for each channel. Even if you make a synchronous operation, changing a frequency later loses the synchronization relationship. If necessary, make a synchronous operation accordingly.

### ■ Operational restrictions

There are restrictions shown in the following table to the synchronous operation. The synchronous operation is used for 2-channel independent operation. Even if the synchronous operation is invalid, making a synchronous operation causes both channels to stop the oscillation once.

Item	Restriction
Waveform	Invalid for noise and DC.
Modulated oscillation mode	Invalid for FM and FSK.
Sweep oscillation mode	Invalid for frequency sweep. Invalid for gated single sweep.
Burst oscillation mode	Invalid .

The delay time varies depending on the output range. Therefore, when the range is different between the channels, the apparent phase difference becomes larger.



## 8.5 Maintaining to Same Frequency (2-Channel Coordination, 2-Phase)

If the channel mode is [2Phase], you can change the frequency with the frequencies for both channels kept the same value while the synchronization relationship is kept. In coordination with the change of frequency of the channel 1, the frequency of the channel 2 is automatically changed. The channel 2 coordinates with the channel 1 also during the frequency modulation or frequency sweep. This function is disabled for the burst oscillation and gated single sweep.

### ■ Selecting 2-channel coordination

Set [Channel Mode]  
to [2Phase]

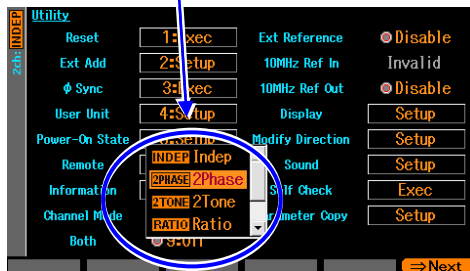

In the Utility screen, set [Channel Mode] to [2Phase] ([Indep] is normally set). This makes the channel mode an oscillation with 2-phase.

Frequencies for both channels will be the same and the phase synchronization is automatically run. Even if changing the frequency, the synchronization relationship is kept. This function controls to keep the synchronization relationship with the same frequency also during the frequency modulation or frequency sweep. For the 2-phase oscillation, the setting relating to the frequency can be set only for the channel 1.

### ■ Changing phase difference between channels

You can set a phase for each channel in the Oscillator setting screen. The phase between channels appears as the difference for each phase setting.

Normally, set the phase of the phase reference channel (for example, channel 1) to 0 degree and change only the phase setting of the channel 2. At this time, the phase setting of the channel 2 is a phase of the channel 2 based on the channel 1. As shown in the figure below, if the phase setting of the channel 2 is positive, the channel 2 precedes the channel 1 and if it is negative, the channel 2 lags behind the channel 1.

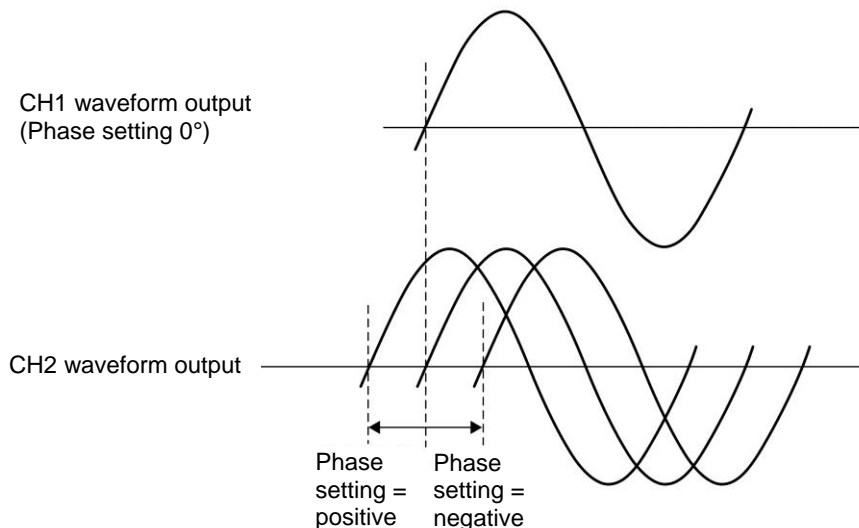

### ■ Operational restrictions

There are restrictions shown in the following table to keep the synchronization relationship with the same frequency:

Item		Restriction
Waveform		Disabled for noise and DC.
Modulated oscillation mode	FM	Both CHs are FM. Peak deviation is common. Modulation source is internal only. Internal modulation waveform and internal modulation frequency are common.
	FSK	Both CHs are FSK. Hop frequency is common. Internal modulation frequency is common.
	PM	Both CHs are PM. Modulation setting is independent for each CH.
	PSK	Both CHs are PSK. Modulation setting is independent for each CH.
	AM	Both CHs are AM. Modulation setting is independent for each CH.
	DC Offset Modulation	Both CHs are DC offset modulation. Modulation setting is independent for each CH.
	PWM	Both CHs are PWM. Modulation setting is independent for each CH.
Sweep oscillation mode	Frequency Sweep	Both CHs are frequency sweep. Sweep function, sweep range, sweep time, and sweep mode are common. Gated single sweep unavailable. Single sweep trigger source and sweep internal trigger oscillator are common. External trigger source is enabled only for CH1 side.
	Phase sweep	Both CHs are phase sweep. Sweep setting is independent for each CH.
	Amplitude sweep	Both CHs are amplitude sweep. Sweep setting is independent for each CH.
	DC offset sweep	Both CHs are offset sweep. Sweep setting is independent for each CH.
	Duty sweep	Both CHs are duty sweep. Sweep setting is independent for each CH.
Burst oscillation mode		Disabled

Both channels have the same type of modulation or sweep during the modulation or sweep. If another channel does not need the modulation (other than FM and FSK) or sweep (other than the frequency sweep), set the modulation width or sweep width of the channel to zero (0).

## 8.6 Keeping Frequency Difference Constant (2-Channel Coordination, 2-Tone)

If the channel mode is [2Tone], you can change the frequency with the frequency difference between both channels kept constant. In coordination with the change of frequency of the channel 1, the frequency of the channel 2 is automatically changed. The channel 2 coordinates with the channel 1 also during the frequency modulation or frequency sweep. This function is disabled for the burst oscillation and gated single sweep.

### ■ Selecting 2-channel coordination

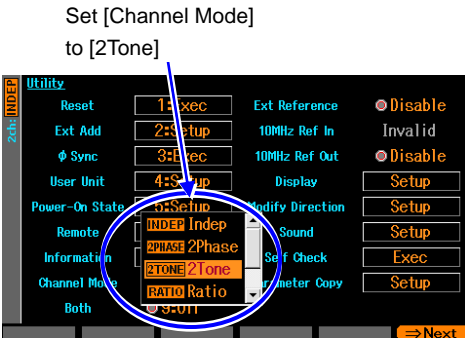

In the Utility screen, set [Channel Mode] to [2Tone] ([Indep] is normally set). This makes the channel mode an oscillation with constant frequency difference.

The frequency difference between both channels is kept constant. This function controls to keep the frequency difference constant also during the frequency modulation or frequency sweep. For the oscillation with the constant frequency difference, you cannot set the frequency of the channel 2 directly.

### ■ To set the frequency difference

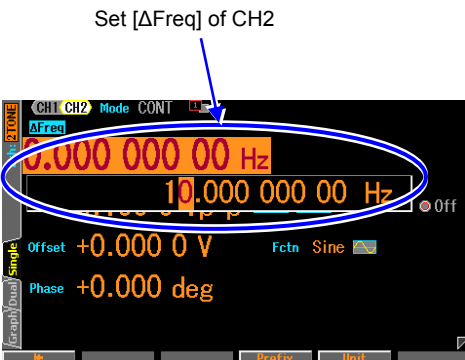

In the Oscillator screen, set the frequency difference in [ $\Delta$ Freq] of channel 2. The frequency of channel 2 results from adding this frequency difference to the frequency of channel 1.

### ■ Operational restrictions

There are restrictions shown in the following table to keep the frequency difference:

Item		Restriction
Waveform		Disabled for noise and DC
Modulated oscillation mode	FM	Both CHs are FM. Peak deviation is common. Modulation source is internal only. Internal modulation waveform and internal modulation frequency are common.
	FSK	Both CHs are FSK. Hop frequency follows the frequency difference. Internal modulation frequency is common.
	PM	Both CHs are PM. Modulation setting is independent for each CH.
	PSK	Both CHs are PSK. Modulation setting is independent for each CH.
	AM	Both CHs are AM. Modulation setting is independent for each CH.
	DC offset modulation	Both CHs are DC offset modulation. Modulation setting is independent for each CH.
	PWM	Both CHs are PWM. Modulation setting is independent for each CH.
Sweep oscillation mode	Frequency sweep	Both CHs are frequency sweep. Sweep range follows the frequency difference. Sweep function, sweep time, and sweep mode are common. Gated single sweep unavailable. Single sweep trigger source and sweep internal trigger oscillator are common. External trigger source is enabled only for CH1 side.
	Phase sweep	Both CHs are phase sweep. Sweep setting is independent for each CH.
	Amplitude sweep	Both CHs are amplitude sweep. Sweep setting is independent for each CH.
	DC offset sweep	Both CHs are offset sweep. Sweep setting is independent for each CH.
	Duty sweep	Both CHs are duty sweep. Sweep setting is independent for each CH.
Burst oscillation mode		Disabled

Both channels have the same type of modulation or sweep during the modulation or sweep. If another channel does not need the modulation (other than FM and FSK) or sweep (other than the frequency sweep), set the modulation width or sweep width of the channel to zero (0).

The frequency difference of the hop frequency in FSK is restricted to the setting resolution of the hop frequency.

If you select the logarithmic sweep as the frequency sweep, the channel 1 performs the logarithmic sweep, but the channel 2 does not perform the logarithmic sweep because the channel 2 follows with the constant frequency difference.

## 8.7 Keeping Frequency Ratio Constant (2-Channel Coordination, Ratio)

If the channel mode is [Ratio], you can change the frequency with the frequency ratio between both channels kept constant. In coordination with the change of frequency of the channel 1, the frequency of the channel 2 is automatically changed.

The channel 2 coordinates with the channel 1 also during the frequency modulation or frequency sweep. This function is disabled for the burst oscillation and gated single sweep.

### ■ Selecting 2-channel coordination

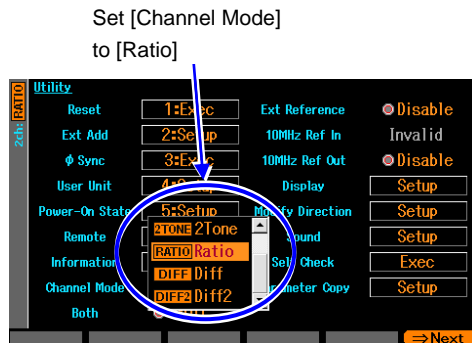

In the Utility screen, set [Channel Mode] to [Ratio] ([Indep] is normally set). This makes the channel mode an oscillation with constant frequency ratio. The frequency ratio between both channels is kept constant. This function controls to keep the frequency ratio constant also during the frequency modulation or frequency sweep. For the oscillation with the constant frequency ratio, you cannot set the frequency of the channel 2 directly.

### ■ To set the frequency ratio

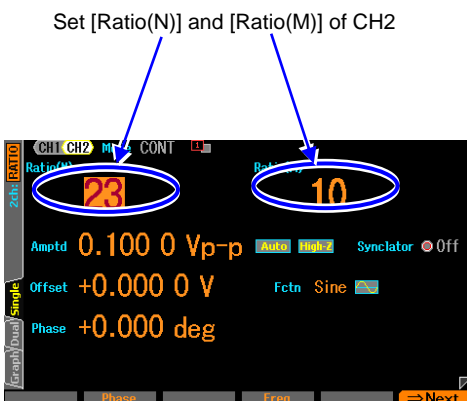

In the Oscillator screen, set the frequency ratio in [Ratio(N)] and [Ratio(M)] of the channel 2. Frequency of channel 2: Frequency of channel 1 will be N:M. If you change the frequency ratio, the phase will be discontinuous temporarily because both channels stop the oscillation once.

### ■ Operational restrictions

There are restrictions shown in the following table to keep the frequency ratio:

Item		Restriction
Waveform		Disabled for noise and DC
Modulated oscillation mode	FM	Both CHs are FM. Peak deviation follows the frequency ratio. Modulation source is internal only. Internal modulation waveform and internal modulation frequency are common.
	FSK	Both CHs are FSK. Hop frequency follows the frequency ratio. Internal modulation frequency is common.
	PM	Both CHs are PM. Modulation setting is independent for each CH.
	PSK	Both CHs are PSK. Modulation setting is independent for each CH.
	AM	Both CHs are AM. Modulation setting is independent for each CH.
	DC offset modulation	Both CHs are DC offset modulation. Modulation setting is independent for each CH.
	PWM	Both CHs are PWM. Modulation setting is independent for each CH.
Sweep oscillation mode	Frequency sweep	Both CHs are frequency sweep. Sweep range follows the frequency ratio. Sweep function, sweep time, and sweep mode are common. Gated single sweep unavailable. Single sweep trigger source and sweep internal trigger oscillator are common. External trigger source is enabled only for CH1 side.
	Phase sweep	Both CHs are phase sweep. Sweep setting is independent for each CH.
	Amplitude sweep	Both CHs are amplitude sweep. Sweep setting is independent for each CH.
	DC offset sweep	Both CHs are offset sweep. Sweep setting is independent for each CH.
	Duty sweep	Both CHs are duty sweep. Sweep setting is independent for each CH.
Burst oscillation mode		Disabled

Both channels have the same type of modulation or sweep during the modulation or sweep. If another channel does not need the modulation (other than FM and FSK) or sweep (other than the frequency sweep), set the modulation width or sweep width of the channel to zero (0).

The peak deviation in FM and the frequency ratio of the hop frequency in FSK are restricted to individual frequency setting resolution.

## 8.8 Obtaining Differential Output (2-Channel Coordination, Differential)

If the channel mode is [Diff], you can change the setting with the differential output of both channels being kept. In this 2-channels coordination mode, the DC offset setting is the same for channel 1 and channel 2. In coordination with the change of setting of the channel 1, the setting of the channel 2 is automatically changed. Coordination is performed also during various modulations or sweeps. This function is disabled for the burst oscillation and gated single sweep.

### ■ Selecting 2-channel coordination

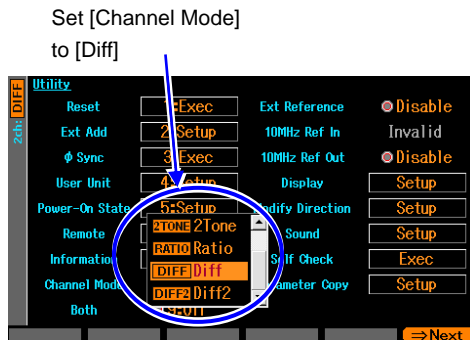

In the Utility screen, set [Channel Mode] to [Diff] ([Indep] is normally set). This makes the channel mode an oscillation with differential output (DC is same polarity).

The frequency, phase, amplitude, and DC offset settings of both channels are the same and the reverse phase waveform is output. Even if changing the various setting, the differential output relationship is kept. This function controls to keep the differential output relationship also during various modulations or sweeps.

For the differential output oscillation, the setting can be set only for the channel 1 (behaves as the oscillator for one-channel).

### ■ Operational restrictions

There are restrictions shown in the following table to keep the differential output:

Item	Restriction
Modulated oscillation mode	Modulation source can be set to internal for FM, PM, AM, AM(SC), OFSM, and PWM. Modulation source can be set to internal or external for FSK or PSK.
Sweep oscillation mode	Gated single sweep not used. External trigger source is valid only for CH1.
Burst oscillation mode	Cannot use.
External addition	Cannot use.

## 8.9 Obtaining Double Output Voltage(2-Channel Coordination, Differential 2)

If the channel mode is [Diff2], you can change the setting with the differential output of both channels being kept. In this 2-channels coordination mode, the DC offset setting for channel 2 is the set value with the reversed sign. In coordination with the change of setting of the channel 1, the setting of the channel 2 is automatically changed. Coordination is performed also during various modulations or sweeps. This function is disabled for the burst oscillation and gated single sweep.

When the hot sides of CH1 and CH2 are used as the output, including DC, it is possible to obtain the double amount of output voltage (however, the output impedance is 100Ω).

### ■ Selecting 2-channel coordination

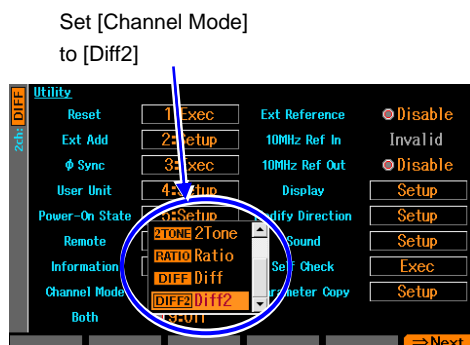

In the Utility screen, set [Channel Mode] to [Diff2] ([Indep] is normally set).

This makes the channel mode an oscillation with differential output (DC is also reversed polarity).

The frequency, phase, and amplitude settings of both channels are the same and the reverse phase waveform is output. DC offset is also of reversed polarity. Even if changing the various setting, the differential output relationship is kept.

This function controls to keep the differential output relationship also during various modulations or sweeps.

For the differential output oscillation, the setting can be set only for the channel 1 (behaves as the oscillator for one-channel).

### ■ Operational restrictions

The restrictions are the same as when the channel mode is [Diff].



## 9. Synchronizing Multiple Units

9.1	Connection Procedure .....	9-2
9.2	Performing Synchronization.....	9-4

Synchronizing multiple units of WF1967 or WF1968 can configure up to 12-phase oscillators (for 6 units of WF1968) without using sub waveform. You can change a phase and amplitude for each phase independently.

Set the same frequency for all units and channels.

## 9.1 Connection Procedure

WF1967 or WF1968 as the synchronous reference is called a "master unit." Other WF1967 or WF1968 is called a "slave unit."

### ■ Used connectors

External 10MHz frequency reference input (10MHz REF IN) and frequency reference output (REF OUT) on the rear panel are used.

### ■ Cables used for connection

Cable type: Characteristic impedance 50Ω series coaxial cable with BNC connector (RG-58A/U etc.)  
Restriction to cable length: 1m or less between units, total cable length is 3m or less

### ■ Connection method

There are two types of connection methods (connection method 1 and connection method 2).

If the number of units is many, using the connection method 1 can reduce the time difference between slave units. However, in addition to the coaxial cable, T-type divider and 50Ω terminating resistor are required.

The connection method 2 is easy to connect because it can make the connection using only coaxial cable. However, the time difference between slave units is larger than that of the connection method 1. The maximum connection number of units is fewer than that of the connection method 1.

Any of the built-in crystal oscillator or external 10MHz clock can be used as the frequency reference for the master unit. If you use the external 10MHz as the reference, the frequency of the slave unit will also be the same accuracy as the external reference.

#### • Connection method 1

Connect the reference output for the master unit to the reference input for the slave unit in parallel using the T-type divider.

Use the 50Ω terminating resistor for the reference input for the terminal slave unit.

Time difference between slave units varies depending on the connection cable length (approximately 5ns/m).

The maximum number of 6 units can be connected, including master and slave units.

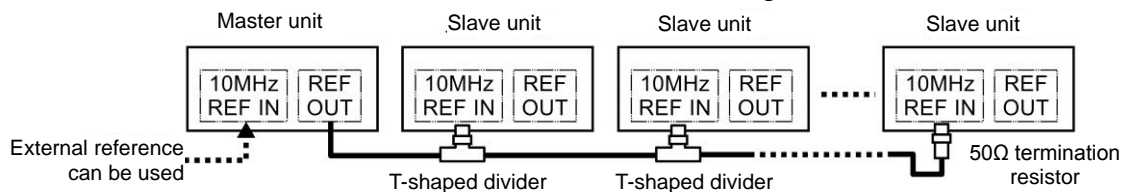

- Connection method 2

Connect the reference output for the master unit or slave unit to the reference input for the next slave unit.

Time difference between slave units varies depending on the delay within units (approximately 25ns) and connection cable length (approximately 5ns/m).

The maximum number of 4 units can be connected, including master and slave units.

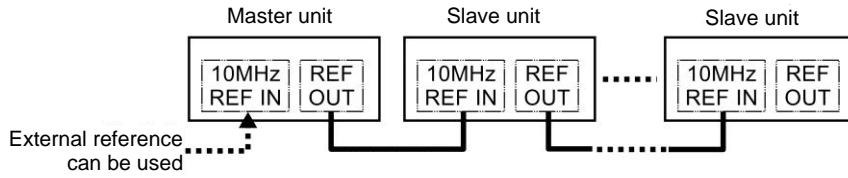

## 9.2 Performing Synchronization

### ■ Before synchronization

After connection among the master unit and slave units is finished, perform the setting as follows:

#### Master unit

- Select 2-channel independent operation or 2-phase operation (in the Utility screen, set the channel mode setting to [Indep] or [2Phase]) (WF1968 only).
- Enable the frequency reference output (in the Utility screen, set 10MHz Ref Out to [Enable]).
- Set the frequency for each channel to the frequency used for synchronous operation of multiple units.
- If you use the external for the frequency reference for the master unit, enable the external frequency reference (in the Utility screen, set the external reference to [Enable]).

Set [Channel Mode] to [Indep] or [2Phase] (WF1968 only)      Set 10MHz Ref Out to [Enable]

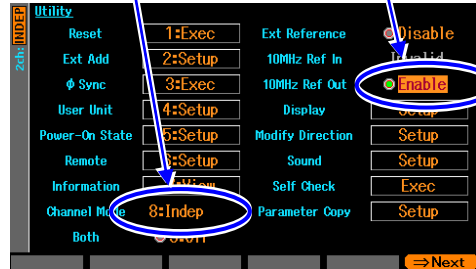

#### Slave unit

- Select 2-channel independent operation or 2-phase operation (in the Utility screen, set the channel mode setting to [Indep] or [2Phase]) (WF1968 only).
- Enable the external frequency reference (in the Utility screen, set the external reference to [Enable]).
- Set the frequency for each channel to the frequency used for synchronous operation of multiple units (common to all units and channels).
- For the connection method 2, enable the frequency reference output (in the Utility screen, set 10MHz Ref Out to [Enable]).

Set [Channel Mode] to [Indep] or [2Phase] (WF1968 only)      Set [Ext Reference] to [Enable]

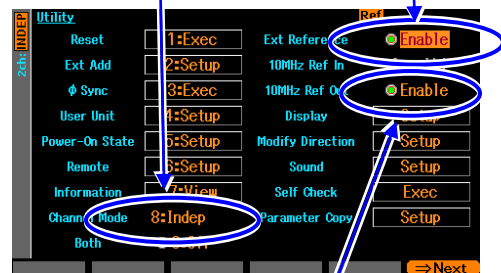

For the connection method 2, set 10MHz Ref Out to [Enable]

Check that all slave units operate based on the external frequency reference. If the [Ref] icon is lit without flashing on the status display area in the top of the screen, they operate based on the external frequency reference.

If they operate based on the external frequency reference, the [Ref] icon is lit without flashing



■ **Performing synchronization**

Synchronous operation is performed in the master unit.

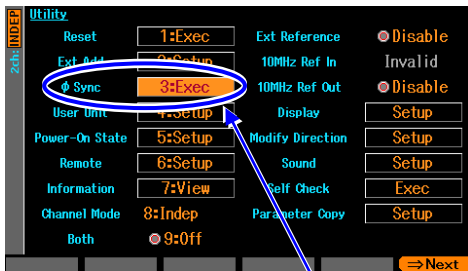

In the Utility screen, select [φSync] and then press the ENTER key to execute the phase synchronization

Synchronous operation is performed in the Utility screen of the master unit.

Select [φ Sync] in the Utility screen, and then press the ENTER key.

This runs the phase synchronization.

At this time, the phase will be discontinuous temporarily because all channels stop the oscillation once.

When the phase synchronization is run, a message is displayed on each unit.

■ **Phase relationship after synchronous operation**

The oscillation phase for each channel is initialized by the synchronous operation. The phase difference of the output waveform appears as the difference of the phase setting for each channel. Even if you make a synchronous operation, changing a frequency later loses the synchronization relationship. Even if the synchronization relationship is lost, no message is displayed. If necessary, make a synchronous operation accordingly.

The synchronization relationship is lost when the connection cable between the master unit and slave unit or between slave units is removed. If you change the setting of channel mode or external frequency reference, the synchronization relationship is lost.

■ **Operational restrictions**

There are restrictions shown in the following table to the synchronous operation. Even if the synchronous operation is invalid, making a synchronous operation causes all channels to stop the oscillation once.

Item	Restriction
Waveform	Invalid for noise and DC
Modulated oscillation mode	Invalid for FM and FSK
Sweep oscillation mode	Invalid for frequency sweep. Invalid for gated single sweep.
Burst oscillation mode	Invalid

MEMO

# **10.Using External Frequency Reference**

- 10.1 Purpose of Using External Frequency Reference ..... 10-2
- 10.2 Connection and Usage Procedure of External Frequency Reference ..... 10-2

## 10.1 Purpose of Using External Frequency Reference

This product uses a built-in crystal oscillator as the frequency reference, but you can also use the external 10 MHz clock as the frequency reference.

Generally, the external frequency reference is used for the following purposes:

- Use the higher accuracy of the frequency reference (for example, a rubidium frequency standard) than that of the frequency reference built in this product to improve the accuracy and stability of the frequency.
- Use the common frequency reference with other units to share the common frequency accuracy.
- Synchronize with other WF1967 or WF1968. For this synchronous operation of multiple units,  P.9-2

## 10.2 Connection and Usage Procedure of External Frequency Reference

### ■ To connect 10MHz signal

Connect the external 10MHz signal to the external 10MHz frequency reference input (10MHz REF IN) BNC terminal on the rear panel.

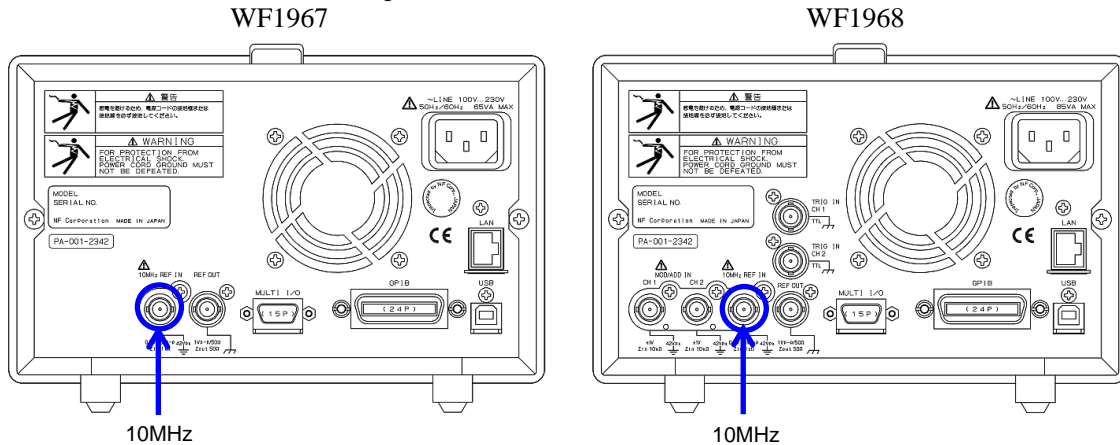

Input characteristics are as follows:

Input voltage	0.5Vp-p to 5Vp-p
Maximum allowable input	10Vp-p
Input impedance	1k $\Omega$ , AC coupling
Input frequency	10MHz ( $\pm 5$ ppm( $\pm 50$ Hz))
Input waveform	Sine or square wave (50 $\pm$ 5% duty)
Signal GND	Insulated from the enclosure and each channel waveform output (maximum 42Vpk)

If reflection is problem, use the terminating resistor since the input impedance is not 50 $\Omega$ .

The signal ground of the external 10 MHz frequency reference input is insulated from the enclosure. Therefore, noise caused by ground-loop does not affect the connection with a frequency standard. Nor does noise caused by ground-loop affect the connection even when synchronously connecting multiple units of WF1967 and WF1968.

Note that, in all cases, the floating voltage should be limited to 42Vpk (DC + AC peak) or lower to prevent electric shocks.

For the caution for the floating ground connection,  "3.3 Cautions on Floating Ground Connection".



---

**⚠ WARNING**

To prevent electric shocks, do not apply a voltage exceeding 42Vpk (DC + AC peak) between the ground of the BNC connectors insulated from the enclosure and the enclosure. Also, do not apply a voltage exceeding 42Vpk (DC + AC peak) between the grounds of the BNC connector groups insulated from the enclosure. "BNC connector groups" used here, indicates multiple BNC connectors that are connected to a common ground. If such a high voltage is applied, the internal voltage limiting elements will try to reduce the voltage, but a too high voltage may cause the product to be burned.

---

---

**⚠ CAUTION**

If a difference in potential exists between the ground of a BNC connector insulated from the enclosure and the enclosure, do not short-circuit the hot side of that BNC connector and the enclosure. This may damage the product.

---

---

**⚠ CAUTION**

If a difference in potential exists between the grounds of BNC connectors, do not short circuit these BNC connector grounds. This may damage the product.

---

■ **Enabling external frequency reference**

You can switch the enabled/disabled for the external frequency reference in the Utility screen.

In the Utility screen, select [Ext Reference], and then press the ENTER key to switch an indicator to [Enable] from [Disable]. This enables the external frequency reference.

If you want to reset to [Disable], press the ENTER key again.

In the Utility screen, select [Ext Reference] and press the ENTER key

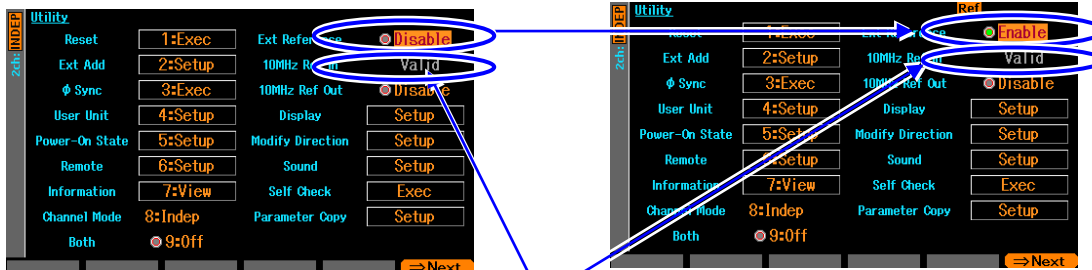

If the available frequency reference is entered, [Valid] is displayed in the [10MHz Ref In] field. Otherwise, [Invalid] is displayed.

If the setting of [Ext Reference] is [Enable] and the status of [10MHz Ref In] is [Valid], then this product operates using the signal input to the external 10 MHz frequency reference terminal as the frequency reference.

If the external frequency reference signal breaks on the way, the frequency reference is automatically switched to the built-in frequency reference. After that, if the external frequency reference signal returns, this product operates using it again as the frequency reference.

What is used as the frequency reference is always displayed on the status display area in the top of the screen.

If the current frequency reference is external, the [Ref] icon is displayed



# 11.Using the Sequence Oscillation

11.1	Sequence Oscillation Example .....	11-2
11.2	Basics .....	11-4
11.3	In-Step Processing Flow .....	11-12
11.4	Setting and Operation Procedure .....	11-13
11.5	Saving Created Sequence .....	11-17
11.6	Using the Saved Sequence .....	11-19
11.7	Deleting the Saved Sequence .....	11-20
11.8	Outline of Screen .....	11-21
11.9	Individual Description of Step Control Parameters.....	11-23
11.10	Tips for Sequence Creation .....	11-24

## 11.1 Sequence Oscillation Example

As a simple example of sequence oscillation, this section describes how to change DC voltage in stages as shown in the following figure.

(First, restore the initial setting in the Utility screen.)

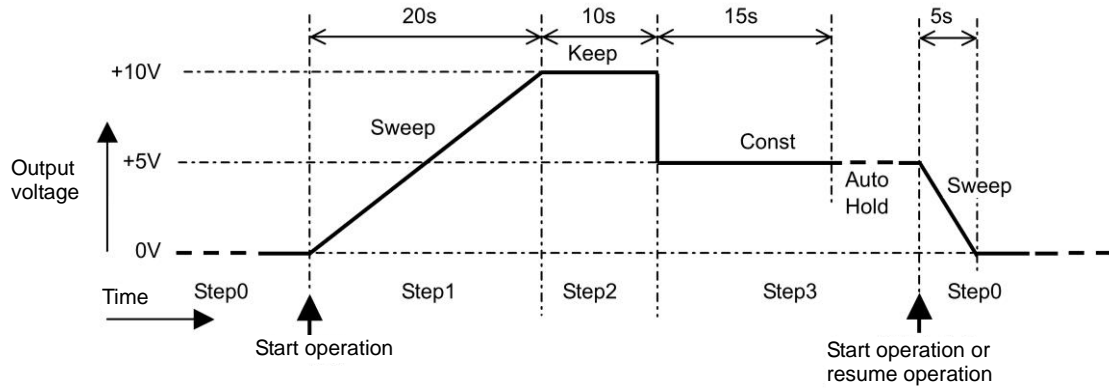

Set the sequence as follows.

Step number	Step control parameters		Intra-step channel parameters
0	Time: 5 s	StopPhs: Off StepCode: any value	Fctn: DC Offset: 0V Action: Sweep
1	Time: 20 s	AutoHold: Off StopPhs: Off StateB: Off EventB: Off JumpTo: Off StepTerm: Continue StepCode: any value	Fctn: DC Offset: +10V Action: Sweep
2	Time: 10 s	AutoHold: Off StopPhs: Off StateB: Off EventB: Off JumpTo: Off StepTerm: Continue StepCode: any value	Fctn: DC Offset: Action: Keep
3	Time: 15 s	AutoHold: On StopPhs: Off StateB: Off EventB: Off JumpTo: Off StepTerm: End StepCode: any value	Fctn: DC Offset: +5V Action: Const

The following section describes the operation in the order of step transition.

### Step 0

These are the output setting before the sequence starts and after the sequence ends.

In this case, the system waits for the sequence to start in the state of DC 0V.

[Time] and [Action] are enabled only when the sequence is stopped. They will be explained later.

### Step 1

When the sequence starts, the sequence goes to Step 1. Since [Time] is set to 20 seconds, [Offset] is set to +10V, and [Action] of [Offset] is set to [Sweep], the output voltage rises linearly from 0V to +10V over 20 seconds.

Once the output voltage has reached +10V after 20 seconds, since [StepTerm] is set to [Continue], the sequence moves on to the next step, Step 2.

### Step 2

Since [Time] is set to 10 seconds and [Action] of [Offset] is set to [Keep], the last value of the previous step, Step 1, which is +10V, is held for 10 seconds.

After the lapse of 10 seconds, since [StepTerm] is set to [Continue], the sequence moves on to the next step, Step 3.

### Step 3

Since [Time] is set to 15 seconds and [Action] of [Offset] is set to [Const], a constant value, which is +5V, is held for 15 seconds. When the sequence moves on from Step 2 to Step 3, the output voltage abruptly changes from +10V to +5V.

After the lapse of 15 seconds, since [AutoHold] is set to [On], the sequence goes into standby in that state.

After that, when stop operation is performed, the sequence moves to Step 0.

Since [StepTerm] is set to [End], the sequence moves to Step 0 even if resume operation is performed.

Note that if the [StepTerm] is set to [Continue], the sequence moves to Step 4 when resume operation is performed.

### Step 0

Since [Time] is set to 5 seconds, [Offset] is set to 0V, and [Action] of [Offset] is set to [Sweep], the output voltage declines linearly from +5V to 0V over 5 seconds.

Once the output voltage has reached 0V after 5 seconds, the sequence goes into standby in that state.

When the start operation is performed at this point, the same sequence is repeated.

## 11.2 Basics

This section describes the necessary information you should know when using the sequence oscillation.

### a) Difference between sequence oscillation and normal oscillation

During sequence oscillation, the unit operates on individual waveform, frequency, and amplitude settings, which are independent from normal oscillation (continuous, modulated, sweep, and burst). In another word, the sequence oscillation and the normal oscillation operate as a separate oscillator independent from each other.

### b) Step control parameters and intra-step channel parameters

Sequence oscillation has the following two main types of parameters.

- Step control parameters

Sequence oscillation consists of multiple steps linked to each other. The step flow is controlled by the step control parameters. These parameters determine the step duration time and the next step. For convenience, the step synchronization code output setting is also included in the step control parameters.

- Intra-step channel parameters

This parameter determines the output status within each step. Along with basic parameters, such as waveform, frequency, and amplitude, it determines how these parameters change within each step.

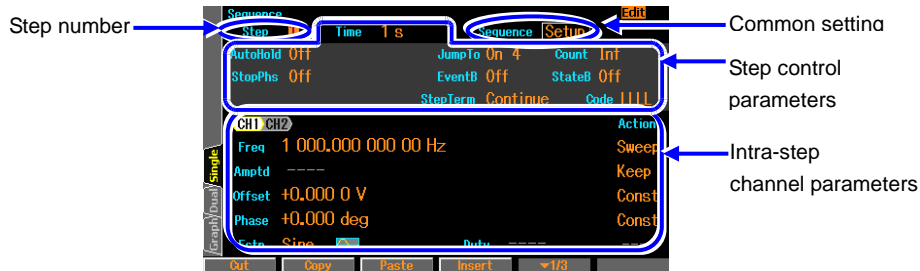

**c) Intra-step parameter change pattern**

Intra-change parameters, except for the waveform, have the following three patterns of value changes within the step. These are called action settings. In case of waveform parameters, there is no action setting. Instead, the setting is always done in that step.

- Constant [Const]  
The value is fixed to that setting specified in the step.
- Keep [Keep]  
The value immediately before the move to that step is maintained. This means, the value changes according to the status of the previous step.  
When the action setting is set to [Keep], you will not be able to perform a set of parameter values.
- Sweep [Sweep]  
The value changes linearly over the step time from the value immediately before the move to that step to the value set in that step. This means, after the lapse of the step time in that step, the value reaches the set value. The starting value changes according to the status of the previous step.

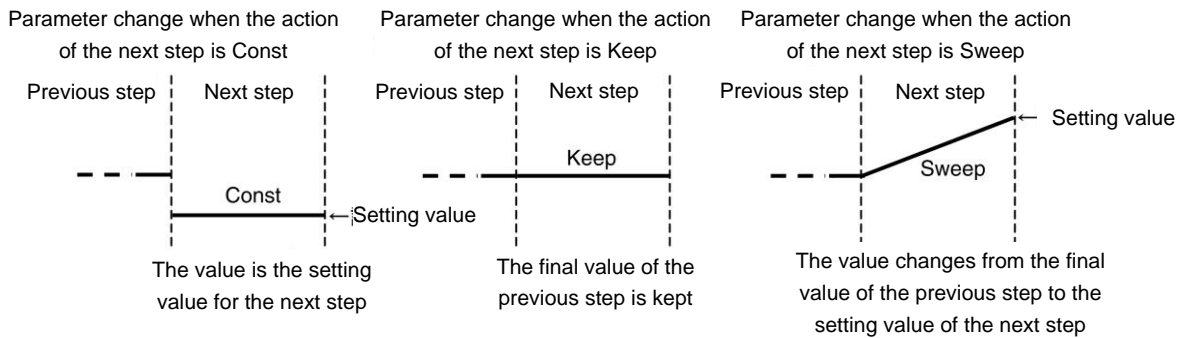
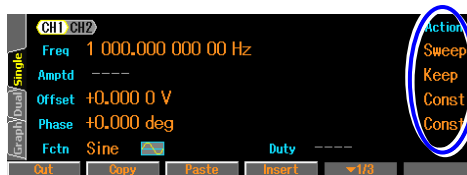

**d) Phase at sequence mode**

In the sequence oscillation, the reference phase is generated internally, the value set in the reference phase in the phase [Phase] will be output are added. Reference phase, frequency / amplitude / offset / phase changes in a continuous even if the change. Also, except for DC and noise, even if the waveform changes and changes continuously. Immediately after output DC and noise will be the reference phase resumes from 0 degree.

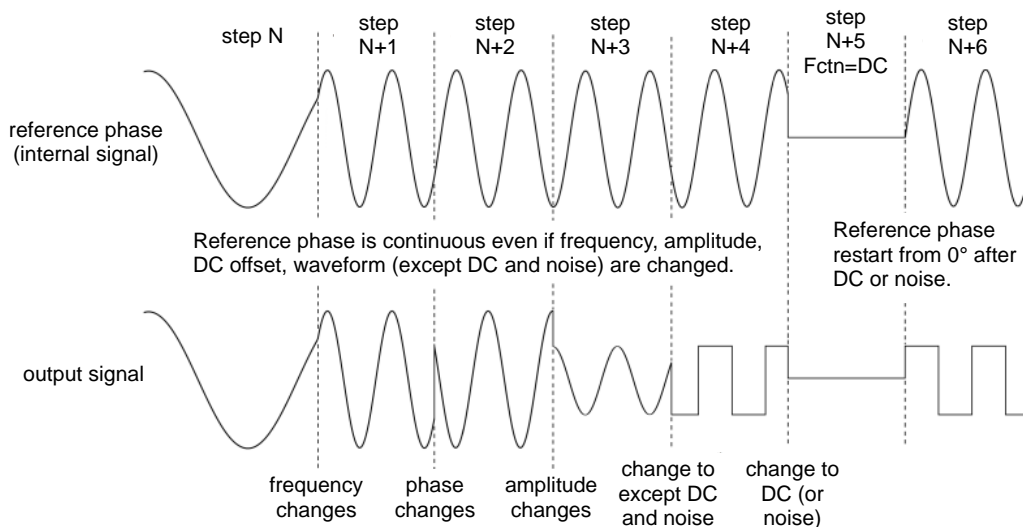

e) Phase at step end [StopPhs]

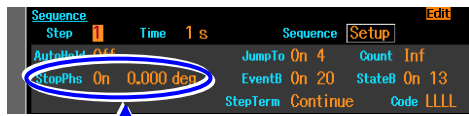

StopPhs setting

Normally, when the prescribed step time has elapsed, the sequence moves on to the next step regardless of the reference phase. However, if you wish to set the sequence to move on to the next step after the completion of one cycle of waveform, it is possible to specify the end phase (stop phase).

However, in WF1968, the end phase setting is enabled only for channel 1. The stop phase cannot be set for channel 2. In addition, when the waveform is a square wave, noise and DC, it is not possible to specify the stop phase.

When the stop phase is specified, after the lapse of the prescribed step time, the sequence moves on to the next step when the specified reference phase has been reached, with the output setting maintained as it is (sweep is not performed during this interval). As a result, the actual step time is longer than the specified step time. The sequence moves on to the next step with a continuous phase regardless of the stop phase setting.

The following figures show the example, in which the stop phase is specified and in which it is not specified, when the phase between steps is quickly changed. Phase setting value is  $0^\circ$  in the previous step and  $90^\circ$  in the next step. Stop phase setting value is  $45^\circ$ . Both, the reference phase at the turn of the steps are contiguous. When StopPhs is On, proceeds to the next step when the reference phase is equal to the set value

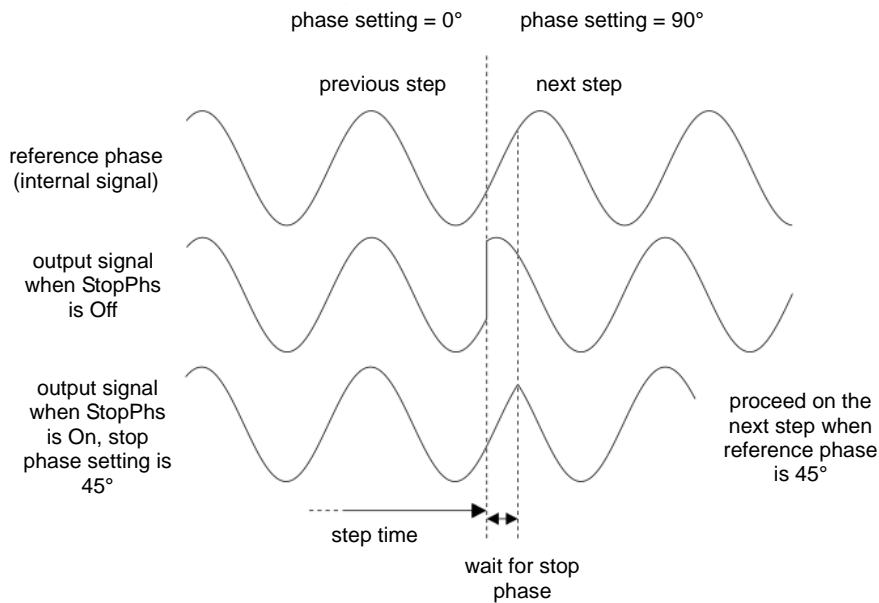

Similarly, following figure show the example, in which the stop phase is a specified and in which it is not specified, when the amplitude is quickly changed.

In the example, both the phase setting value and the stop phase setting value are  $0^\circ$  when a stop phase is specified. In both cases, the phase is continuous at the transition of the steps.



When a stop phase is not specified in the previous step

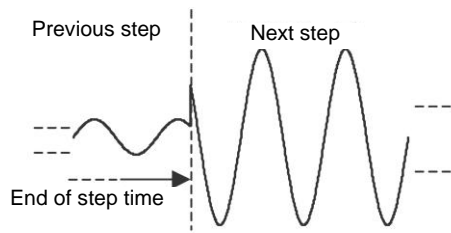

When a stop phase is specified in the previous step

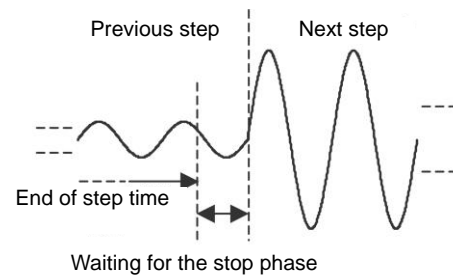

✓ Check

- Stop phase setting is disabled for a square wave, noise and DC.
- The sequence changes to the next step after approximately 350ns (equivalent to  $0.126^\circ$  in 1kHz) has elapsed from the specified stop phase.

**f) Phase at step start**

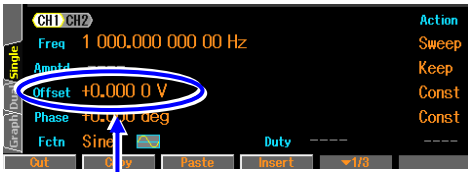

Phase setting

If the waveform of the previous step is DC or noise, oscillation in the next step starts from reference phase  $0^\circ$ . Phase  $0^\circ$  here is the phase value based on the reference phase as in the case of the phase at step end (stop phase). The start phase that appears in the actual output is the phase setting value of that step. If the phase is set to  $0^\circ$ , oscillation starts from  $0^\circ$ .

The following figures show the examples of when the phase is set to  $0^\circ$  and when the phase is set to  $90^\circ$ , where the step after DC is sine wave.

Phase setting for the next step= $0^\circ$

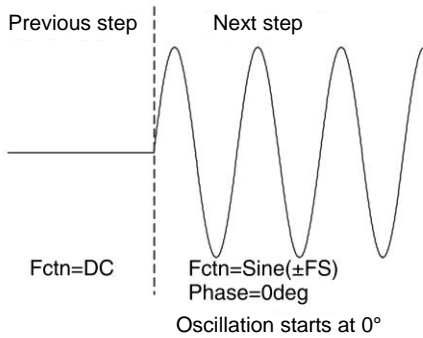

Phase setting for the next step= $90^\circ$

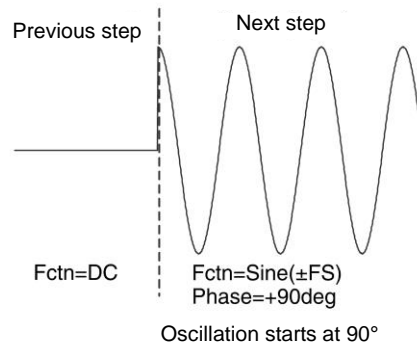

✓ Check  
Set the previous step to DC to specify a start phase.

**g) Frequency next DC and Noise**

In the next step of the DC or noise, when the case where the action of frequency to Sweep, sweep first from 1kHz.

### h) Two types of branches

The control flow can be changed by the panel operation or by the external signals. This is called branching. For example, branching can be used to set the sequence to move to a different step in response to a status change of the equipment under test.

There are two types of branches as follows:

- State branch [StateB]

The operation branches to the specified step according to a signal from a multi-I/O connector (pin 14). [P.11-11](#)

However, the signal from the multi-I/O connector is checked only after the lapse of the specified step time of that step (excluding the time being held). [P.11-12](#)

- Event branch [EventB]

The operation branches immediately to the specified step according to the soft key operation or the signal from a multi-I/O connector (pin 11). Even if the stop phase has been set, it is ignored. For example, it can be used for saving processes when a failure is detected.

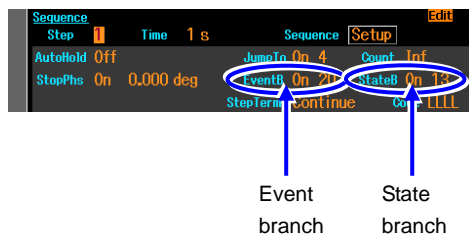

### i) Step 0 before the start and at the end

The step in a standby state before the start of sequence is called Step 0. Step 0 is also the state at the end of sequence. When the mode changes from the normal oscillation mode to the sequence oscillation mode, the status changes to the Step 0 output status.

Since this is a special step, the items that can be set to the step control parameters and their meanings are different from those of other steps.

Only the following three items can be set for the step control parameters.

- Step time: At the start of sequence, the sequence changes to the next step (normally Step 1) without waiting for this time. The step time is enabled when parameters are swept at the sequence end. When sweep is set in the intra-step channel parameter setting of Step 0, sweeping is performed for the duration of this time. [P.11-5](#)
- Stop phase: At the start of sequence, the sequence waits for the reference phase specified here and then moves to the next step (normally Step 1). This setting is disabled for a square wave, noise, and DC.
- Step synchronization code output: This is the step synchronization code output of Step 0. The action setting of intra-step channel parameters consists of [Const] (constant) and [Sweep] (sweep) only. It does not include [Keep] (keep). This means, the same output setting is always applied to the start and the end.

**j) Limitation of available waveform**

The waveforms that can be used for sequence oscillation are limited to sine wave, square wave (both standard and extended duty variable range), noise, DC, and arbitrary waveform.

When you wish to use a ramp wave or parameter-variable waveform, copy the desired waveform to the arbitrary waveform and save it as an arbitrary waveform in advance in the ARB Edit screen.

During sequence oscillation, it is not possible to specify the symmetry of ramp wave or the parameters of the parameter-variable waveform.

When you wish to use a pulse waveform, save the half sine edge pulse of the parameter-variable waveform as an arbitrary waveform.

**k) Waveform size**

The waveforms used in the sequence are not written to the waveform memory each time the step is executed. Before the execution of sequence, the waveforms are expanded to the 1MiW waveform memory (per channel) during compilation. Therefore, when many types of waveforms are used, a memory size allocated to each waveform becomes consequently smaller. However, since DC and square wave (regardless of whether the duty variable range is standard or extended), they do not use the waveform memory. In addition, the required memory size does not change when the same waveform is used repeatedly. The number of types of waveform that can be used is limited to 128. Beware of the following points:

- When the allocated memory size becomes small, an arbitrary waveform in the control point format with many abrupt changes may lose the characteristics of the waveforms.
- When a large-waveform is used in an arbitrary waveform in the array format, the memory size allocated to other waveforms becomes smaller.

The following table shows the memory size that can be allocated to each waveform.

Waveform	Size	Size adjustment
DC	0W	Fixed
Square wave	0W	Fixed
Sine wave	4KiW, ...512KiW, 1MiW (power of 2)	Variable
Noise	32KiW	Fixed
Arbitrary waveform (control point format)	4KiW, ...512KiW, 1MiW (power of 2)	Variable
Arbitrary waveform (array format)	4KiW, ...512KiW, 1MiW (power of 2)	Fixed

When a parameter-variable waveform, square waveform, pulse waveform, or ramp waveform is copied to an arbitrary waveform, it becomes an arbitrary waveform in control point format.

Noise is always used in a memory size of 32KiW. The size is fixed. However, this does not mean that the same pattern is repeated during output.

An arbitrary waveform in the array format is used with the waveform size, which is transferred from USB or GPIB, and the size is fixed.

A sine wave and an arbitrary waveform in the control point format are allocated to the remaining memory size, which is 1MW minus the total size of the fixed-length waveform shown above. The waveform size is adjusted based on the free memory space and the number of waveforms. However, all memory sizes allocated to each variable-length waveform are the same.

The arbitrary waveforms in the control point format are not simply thinned but expanded to the memory in a way, so that the characteristics of the waveform are maintained as much as possible.

Caution: In the initial setting, waveforms in all steps are sine wave and the step terminal is set to [Continue]. If the initial setting is not changed, when a 1MiW arbitrary waveform in the array format is specified in an arbitrary step, an error occurs during compilation due to insufficient memory space to allocate the sine wave to the waveform memory. When using a 1MiW arbitrary waveform in the array format, create a sequence which does not go through the steps requiring another waveform memory.

### l) Channel coordination (WF1968 only)

The step control parameters are common to both channels. The sequence makes the same step transition for both channels. However, since the stop phase can be controlled only by the channel 1 side, the stop phase of channel 2 does not necessarily match the desired value.

On the other hand, the intra-step channel parameters can be set independently for each channel.

### m) Common setting for sequence



Select [Setup] and press the ENTER key to open the window for common setting

Window for common setting

The following items are common settings within one sequence.

- Start step [Start Step]  
The number of the next step, to which the sequence moves to after Step 0, can be specified. Usually, this is set to 1.
- External trigger polarity [Trig]  
When using the external trigger input (BNC terminal) as the sequence start trigger, the polarity of trigger can be specified. When it is not used, set this item to Off.  
In WF1968, only the trigger input terminal on the channel 1 side is enabled.
- External control [ExtCtrl]  
Enable this item to control start, stop, hold/resume, and branch of the sequence by using the signal from the multi-I/O connector (set to [Enable]). When the multi-I/O connector is not used, disable this setting (set to [Disable]). [P.11-16](#)
- Allocation of the pin 14 of multi-I/O connector [Multi I/O pin14]  
Pin 14 of the multi-I/O connector can be allocated either to the sequence start (set to [Start]) or to the state branch (set to [StateBranch]).  
[P.11-16](#)
- Synchronization output [SyncOut]  
This selects whether to output the waveform synchronization signal (set to [Sync]) or LSB (set to [StepCode (LSB)]) of the step synchronization code to the synchronization/sub-output terminal.  
For the step synchronization code, [P.11-23](#).  
If LSB of the appropriate step synchronization code is set to H and output, it can be used as the trigger source. Using this, a simplified check for sequence can be executed with an oscilloscope.  
For multi-I/O connector, [P.3-15](#).

### n) Other limitations

- The amplitude range is automatically determined according to the maximum output level of the overall sequence. During the sequence execution, the range switching does not occur.
- The external addition function is forcibly set to off.
- As to the amplitude and DC offset load impedance conditions, the value set in the oscillator screen is used.

### 11.3 In-Step Processing Flow

The following figure shows the flow of processing within one step.

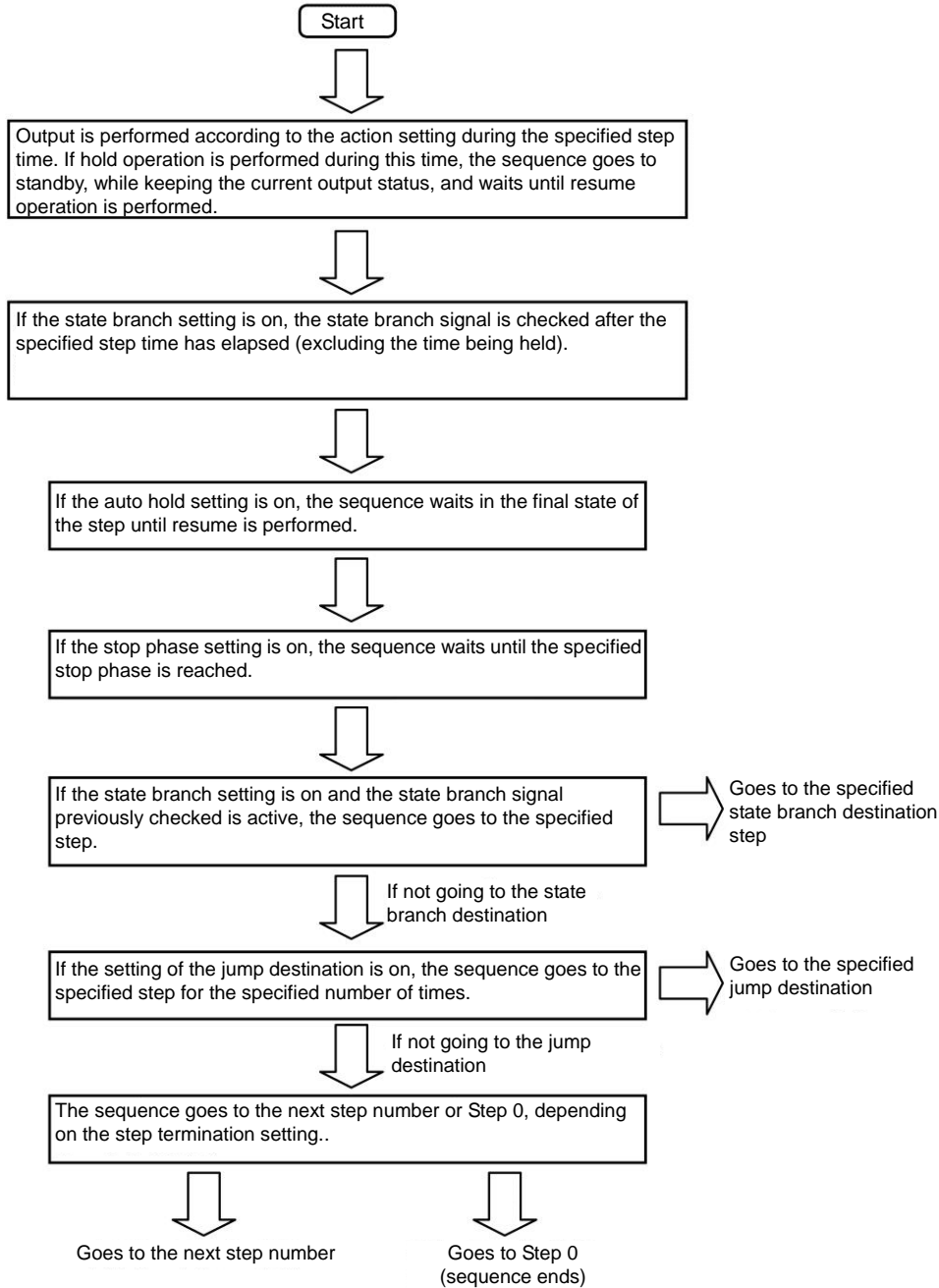

Following transitions occur as the result of event branching or termination operation, regardless of the flow in the step.

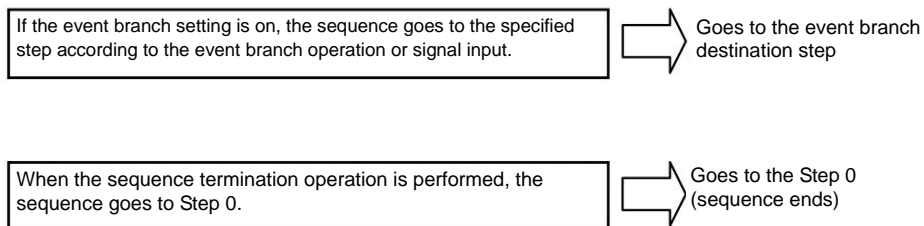

## 11.4 Setting and Operation Procedure

### a) Switching to sequence oscillation mode

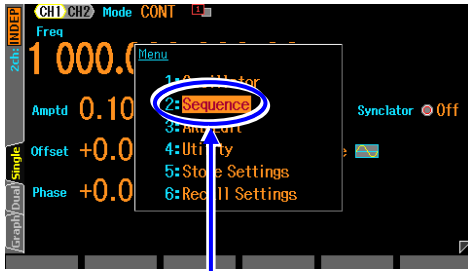

In the top menu, select [Sequence] and then press the ENTER key

1. Press the MENU key to open the top menu window. Then select [Sequence] and press the ENTER key.
2. The dialog box to confirm the move to the sequence oscillation mode is displayed. Select [OK] and press the ENTER key. This will move to the sequence oscillation mode.  
The sequence creating/editing window is displayed with the output setting for Step 0.

### b) Creating/editing a sequence

To use a sequence which is already saved, press the [Recall] soft-key and select the sequence to be used.

To create a new sequence, perform the setting step by step.

To use the existing setting contents, copy and paste either the entire setting of step control parameters and intra-step channel parameters or the intra-step channel parameters only (using the soft key).

During editing, the contents of the selected step are output.

In the sequence creating/editing screen, [Edit] is displayed at the top right corner of the screen. The soft key items in the sequence creating/editing screen are as follows:

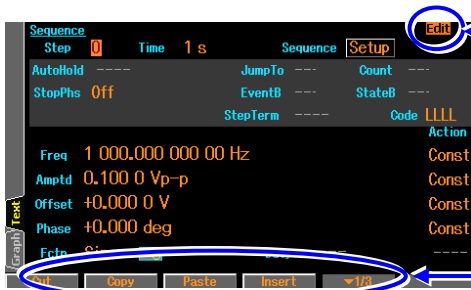

It is displayed with the Edit in creating and editing screen.

There are three rows of soft-keys

#### Soft keys in [Edit] status

First row



It indicates first row

Step parameters (both step control parameters and intra-step channel parameters) corresponding to the step number currently displayed can be copied and pasted, or the step itself can be cut and inserted. Even when a step is cut and inserted, the step numbers referenced in each step (jump destination and branch destination) are not changed.

Second row (Text screen or Single and Dual screens of WF1968)



It indicates second row

Step numbers are increased and decreased by using [Step +1] and [Step -1].

Intra-step channel parameters corresponding to the step number currently displayed can be copied and pasted by using [CH Copy] and [CH Paste]. In WF1968, these soft keys function on the

active channel.

Second row (Graph screen)



The input field corresponding to the step number can be opened by [Step].

Use [AutoScale] to adjust the vertical axis scale of the graph displayed so that the scale does not become saturated.

The setting screen for the displayed item and the displayed scale can be opened by [TRC Setup].

Third row



It indicates third row

A sequence can be saved and recalled by using [Store] and [Recall], respectively.

All sequence settings can be initialized by using [Reset].

A sequence becomes executable by using [Compile].

**c) Performing sequence execution preparations**

Just calling up or creating/editing a sequence does not make the sequence executable.

When the [Compile] (compilation) soft key is pressed in the [Edit] status, the setting contents are checked if they are appropriate, the waveform data is allocated, and the optimum output range setting is performed to make the sequence executable (Ready).

As a result of compilation, when any setting not preferable for execution is found, an error message is displayed.

When the compilation is completed properly and the sequence becomes executable, [Rdy] is displayed at the top right corner of the screen. The soft key items in this status are as follows:

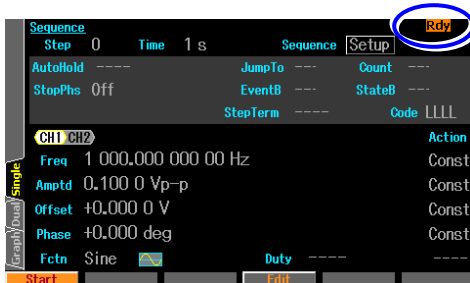

It is displayed as Rdy  
Upon successful  
compilation

**Soft keys in [Rdy] status**



Sequence execution is started by [Start].

The screen returns to the creating/editing sequence screen by [Edit].

The created or edited sequence is cleared when the power is turned off. Save the sequence as needed. Save setting window is opened by pressing the [Store] soft-key in the [Edit] status. The sequence can be saved either before or after the [Compile] operation (only in [Edit] status).

**d) Executing the sequence**

Press the [Start] soft key in the [Rdy] screen to start the sequence execution.

When the sequence is started, [Run] is displayed at the top right corner of the screen. The soft key items in this status are as follows:



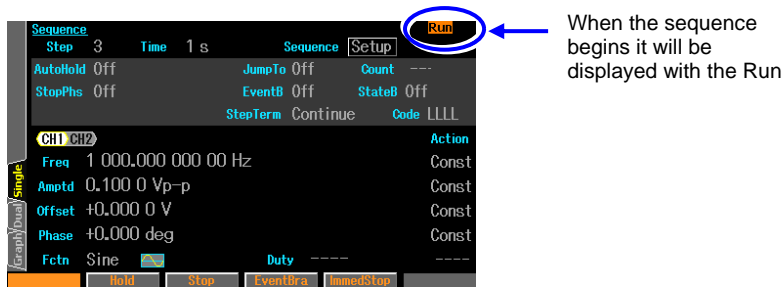

**Soft keys in [Run] status**



**e) Pausing sequence execution**

Press the [Hold] soft key in the [Run] status to pause the sequence. The sequence goes into the standby, while keeping the output condition as it is. To resume the sequence, press the [Resume] soft key in the [Hold] status.

During hold status, [Hold] is displayed at the top right corner of the screen. The soft key items in this status are as follows:

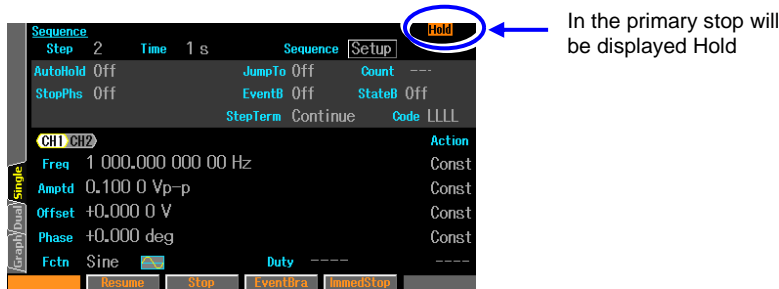

**Soft keys in [Hold] status**



**f) Executing an event branch**

Press the [EventBra] soft key in the [Run] or [Hold] status to execute an event branch. If the event branch is set to on in the step which is being executed at that moment, the sequence moves to the specified step.

**g) Terminating the sequence**

Press the [Stop] soft key in the [Run] or [Hold] status to terminate the sequence. The sequence moves to Step 0.

[Rdy] is displayed at the top right corner of the screen. The sequence can be restarted at any time.

**h) Forcibly terminating the sequence without waiting for the stop phase or sweep**

Press the [ImmedStop] soft key in the [Run] or [Hold] status to immediately terminate the sequence without waiting for the stop phase or sweep execution. The setting switches to Step 0.

**i) Editing the sequence again**

Press the [Stop] soft key in the [Run] or [Hold] status to terminate the sequence. When it has terminated, press the [Edit] soft key in the [Rdy] status to enable creating and editing the sequence again.

To execute the sequence, press the [Compile] soft key in the [Edit] status again.

**j) Returning to normal oscillation mode**

Select other than [Sequence] (such as [Oscillator]) in the top menu and then press the ENTER key. The dialog to confirm the exit from the sequence oscillation mode is displayed. Select [OK] and then press the ENTER key. This switches back to the normal oscillation mode.

In the sequence oscillation mode, displaying the other items of the top menu means switching to the normal oscillation mode.

**k) Controlling the start, stop, and pause of the sequence by using an external logic signal**

When the external control [ExtCtrl] in the common setting is set to [Enable], the sequence operation can be performed by the TTL level logic input to the multi-I/O connector on the rear panel.  P.11-11

It is recommended that this be set to [Disable] when not using an external control signal in order to avoid malfunctions caused by exogenous noise.

For the multi-I/O connectors and their pin allocation,  P.3-15

During the external trigger input (BNC terminal), only the sequence start operation can be performed.  P.11-11

The following operations are available:

**■ Starting a sequences**

Falling input in the [Rdy] status starts a sequence. This is disabled in the [Run] or [Hold] status.

**■ Stopping a sequences**

Falling input in the [Run] or [Hold] status ends the sequence and switches to Step 0.

**■ Holding/resuming sequences**

Falling input in the [Run] status pauses the sequence. Rising input during pause, or in the [Hold] status, resumes the sequence from where it has been paused.

**■ Event branch of the sequence**

In the [Run] or [Hold] status and in the step where event branch is set to on, a falling input generates an event branch. The sequence changes to the specified event branch destination step.

**■ State branch of the sequence**

In the [Run] or [Hold] status and in the step where state branch is set to on, a low level input generates a state branch. The sequence changes to the specified state branch destination step. For the timing to check the low level input,  P.11-12.

It is not possible to control both the sequence start and the state branch via the multi-I/O connector ( P.11-11). When using the multi-I/O connector for the state branch, use the external trigger input (BNC terminal) for the sequence start operation.

**✓ Check**

- Start, stop, and event branch operations via the multi-I/O connector causes a delay of approximately 0.2ms to 1.5ms and fluctuations.
- Start operations by the external trigger input causes a delay of approximately 15 $\mu$ s and fluctuations upon the waveform output, and a delay of approximately 18 $\mu$ s and the fluctuations upon the DC output. The start operation from the external trigger input is faster than that from the multi-I/O connector.

## 11.5 Saving Created Sequence

### 11.5.1 Saving to the Built-In Memory of Main Body

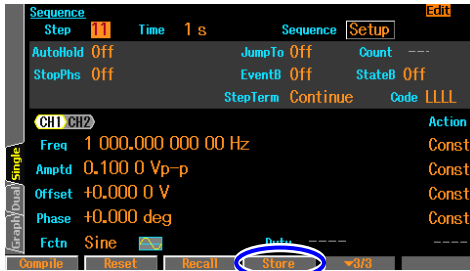

Screen is displayed for the save by pressing the "Store" soft key

Select sequence number



Erase sequence

Sequence name change

Select Internal tab and press the ENTER key to save to built-in memory

1. Press the [Store] soft-key in the [Edit] status to switch to the screen for saving.

2. Select Internal tab at the left bottom side of the screen and press the ENTER key to switch the saving location.

Select a desired sequence number from 1 to 10 and press the [OK] soft key. The sequence being edited at the moment is copied to the built-in memory of the main body. You can also name the sequence.

### 11.5.2 Saving to the USB Flash Memory

USB interface in use, USB memory cannot be used.

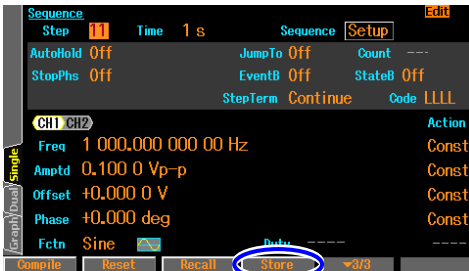

Screen is displayed for the save by pressing the "Store" soft key

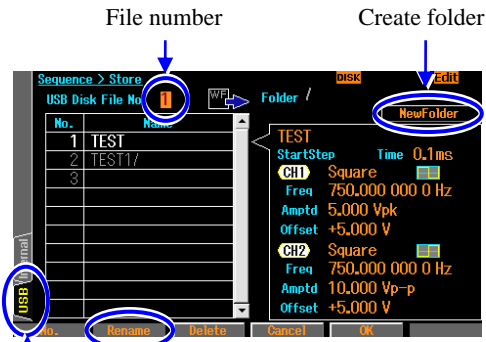

It indicates save to USB flash memory  
It is possible to rename

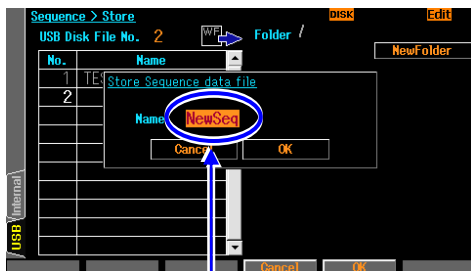

Enter the file name, if you are newly saved.

1. Press the [Store] soft-key in the [Edit] status to switch to the screen for saving.

2. Select USB tab at the left bottom side of the screen and press the ENTER key to switch the saving location. Select the file number, and then press the ENTER key. Folder is marked with "/" to the end of the name. When you press the [Enter] soft key while selecting the folder, you can specify the selected folder as the current folder (use "../" to move one level up in the hierarchy).

To rename the selected file/folder, press the [Rename] soft key. A dialog appears, where you can rename the file/folder. Enter the name here and press the [OK] soft key to rename the file/folder.

When you press the [NewFolder] button and press the ENTER key, the dialog box appears, where you can specify the name of a new folder you create. Enter the name and press the [OK] soft key. The new folder is created under the current folder and appears in the file list.

3. If you are newly saved, specify the last file number that is on the screen, so you can press the [OK] soft key displays a dialog, put the name of the file, and please press the [OK] soft key.

If you want to overwrite, you can specify the number of overwrite files.

When you press the [OK] soft key while you have selected a non-folder, dialog will appear. Enter the file name and press the [OK] soft key to save the sequence being edited in the current folder.

## 11.6 Using the Saved Sequence

### 11.6.1 Recalling from the Built-In Memory

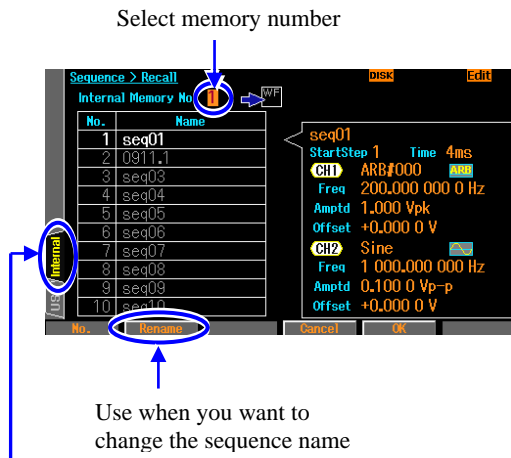

1. Press the [Recall] soft-key in the [Edit] status to switch to the screen for recalling the saved sequence.
2. Select Internal tab at the left bottom side of the screen and press the ENTER key to switch the recalling source.
3. Select a desired memory number from 1 to 10 and press the [OK] soft key. The contents are read from built in memory.
4. To rename the sequence, press the [Rename] soft key in this screen.

### 11.6.2 Recalling from the USB Flash Memory

USB interface in use, USB memory cannot be used.

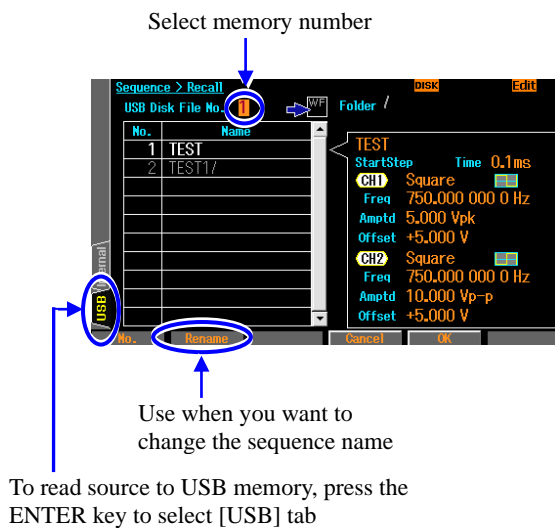

1. Press the [Recall] soft-key in the [Edit] status to switch to the screen for recalling the saved sequence.
2. Select USB tab at the left bottom side of the screen and press the ENTER key to switch the recalling source.
3. Press the [OK] soft key when you have selected the file, and Reads the sequence from the specified file.
4. Folder is marked with "/" to the end of the name. When you press the [Enter] soft key when you have selected the folder, and then move to the specified folder (the folder up one in the selection of the "../").

## 11.7 Deleting the Saved Sequence

To delete the sequence is done in the save screen. Therefore, operation of up to save is the same.

### 11.7.1 Deleting from the Built-In Memory

The sequence which was stored in the specified built-in memory is deleted and restored to the initial state. Sequence names are also initialized to "seq01" to "seq10."

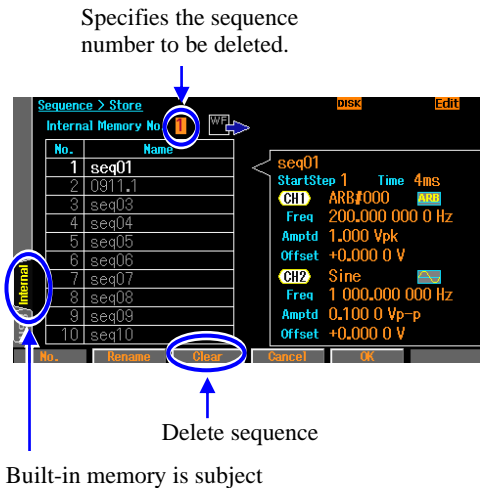

1. In the [Edit] state, and press the [Store] soft key to switch to the screen for the save. In this screen, it is possible to delete the sequence memory.
2. Select a desired memory number 1 to 10 and press the [Clear] soft key. Dialog box prompting the confirmation is displayed. When you press the OK soft key, built-in memory for the specified number is the initial values. Sequence name is also initialized to "seq01" to "seq10".

### 11.7.2 Deleting from the USB Flash Memory

USB interface in use, USB memory cannot be used.

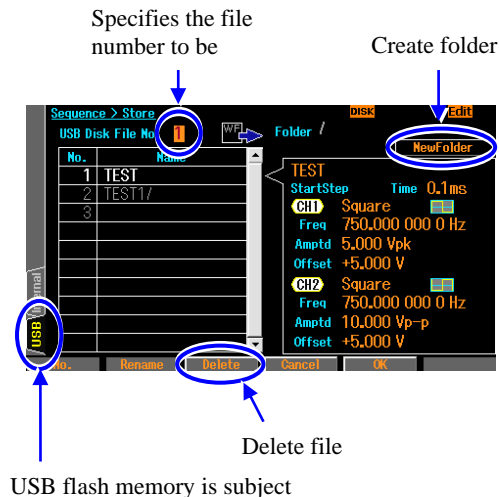

1. In the [Edit] state, and press the [Store] soft key to switch to the screen for the save. In this screen, it is possible to delete the sequence memory.
2. In order to target the USB memory, select the USB tab at the bottom left of the screen, and then press the ENTER key.
3. To select a file or folder, select the file number that is on the screen, and then press the ENTER key.
4. When you press the [Delete] soft key when you have selected the file, the specified file name is removed.
5. Folder is marked with "/" to the end of the name. When you press the [Enter] soft key when you have selected the folder, and then move to the specified folder (the folder up one in the selection of the "..").

## 11.8 Outline of Screen

■ Text display [Text] (WF1967) or [Single] (WF1968)

The step control parameters of one step and the intra-step channel parameters of one channel are displayed simultaneously.

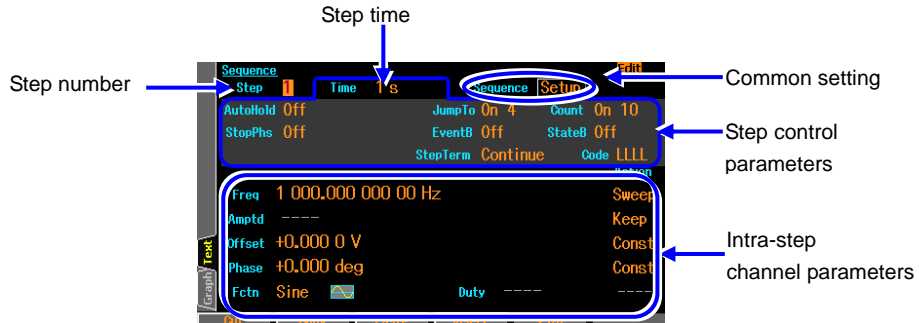

■ 2-channel simultaneous display [Dual] (WF1968 only)

The intra-step channel parameters of one step are displayed for two channels simultaneously. For the step control parameters, only the step time is displayed.

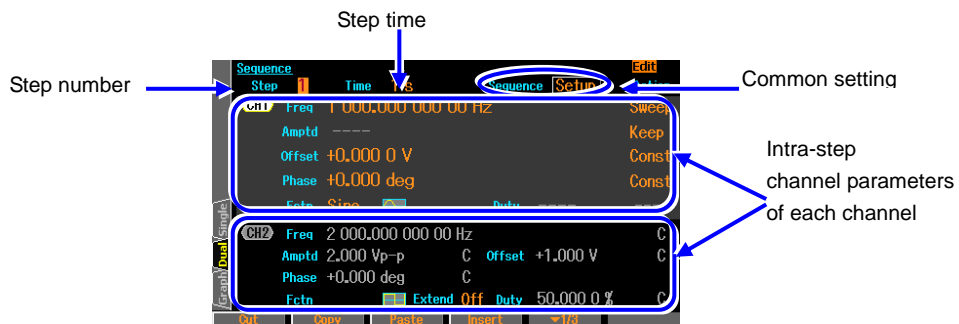

■ Graph display [Graph]

Graph display shows the trends along the step progress for four intra-step channel parameters. However, the trend shown is only for the case where the step progresses according to the step number from Step 0. Status of the case where the sequence does not progress according to the step number due to jump and branch is not displayed.

Which parameter to be displayed in which trace can be set in the trace setting.

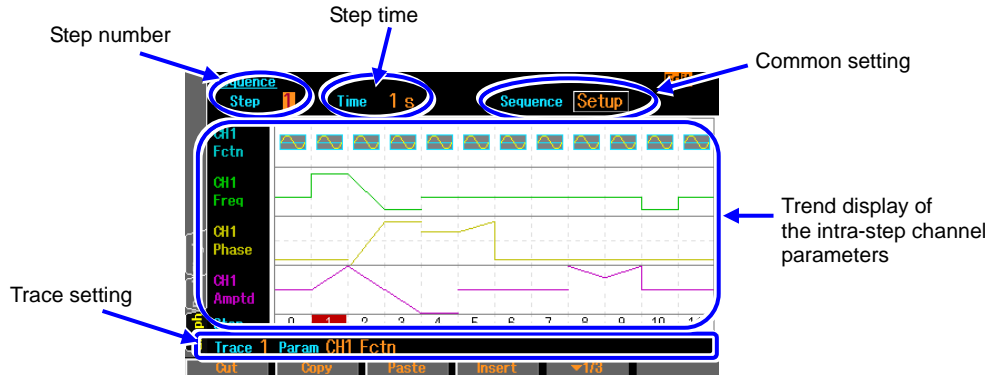

[PRM] and [SCL] displayed in the trace settings indicate the display item and the height of the trace frame, respectively. [OFS] indicates the bottom value of the trace frame for frequency, amplitude, and duty, and the center value of the trace frame for offset and phase.

With the [TRC Setup] soft key in the second row, the settings of four traces and the graph colors can be changed collectively.

The [AutoScale] soft key in the second row adjusts the vertical-axis scale of the graph displayed, including the unused steps, so that the scale does not become saturated.



---

## 11.9 Individual Description of Step Control Parameters

### Step time [Time]

This parameter sets the step duration.

### Auto hold [AutoHold]

Usually, set to Off.

Set this parameter on when the sequence goes into standby without moving on to the next step after the lapse of the specified step time. This is useful when you want to move the sequence while checking the status of the equipment under test step by step.

When the resume operation or resume signal is received, the processing resumes.

### Stop phase [StopPhs]

When this parameter is set to on, the reference phase at the end of that step can be specified.

After the lapse of the specified step time, that step ends when the specified reference phase has been reached.

☞ P.11-6

### Jump destination [JumpTo]

When this parameter is set to on, the next step which the sequence moves to after the end of the current step can be specified.

By specifying the jump count [Count], it is possible to configure a loop which repeats the same step.

### Jump count [Count]

When this is set to on, it is possible to specify the number of jumps to the step specified with [JumpTo] (jump destination). When this is set to [Inf], jump is repeated for infinite number of times.

Note that the number of times that the same step is repeated is [jump count + 1].

### State branch [StateB]

When this is set to on, the state branch signal of multi-I/O connector (pin 14) is checked and if the signal is active, the sequence moves to the specified step. However, the state branch signal can be checked only after the lapse of the specified step time of that step (excluding the time being held).

☞ P.11-9 and P.11-12

### Event branch [EventB]

When this is set to on, the soft keys or event branch signal of multi-I/O connector (pin 11) is checked and if the signal is active, the sequence moves to the specified step.

☞ P.11-9 and P.11-12

### Step termination [StepTerm]

This parameter specifies whether to jump to the next number step ([Continue]) or to go to Step 0 and end the sequence ([End]) upon termination of the step.

### Step synchronization code output [StepCode]

This parameter sets the 4-bit logic signal that is output to the multi-I/O connector while on that step. The right-most bit is D0 (LSB).

For multi-I/O connector, ☞ P.3-15.

D0 (LSB) can be output to the synchronization/sub-output terminal. ☞ P.11-11

## 11.10 Tips for Sequence Creation

### Repeating the same pattern for more than 10 000 times

The maximum value for setting the jump count is 9 999; therefore, up to 10 000 times of step patterns can be repeated. To repeat the same pattern more than 10 000 times, the following methods can be performed. In this example, a case of the repetition for 30 000 times is described.

#### ■Aligning the same patterns

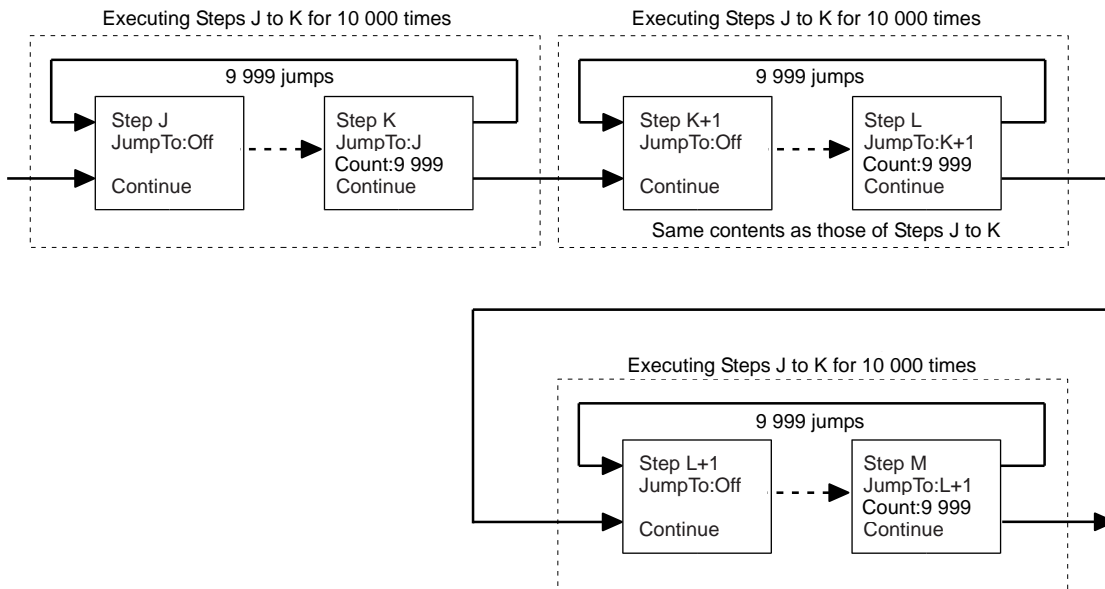

Steps with the same contents can be created easily by using the [Copy] and [Paste] soft keys. Create the steps with the same contents and then revise only the required portions.

#### ■ Creating a multiplex loop by inserting steps to connect the step patterns

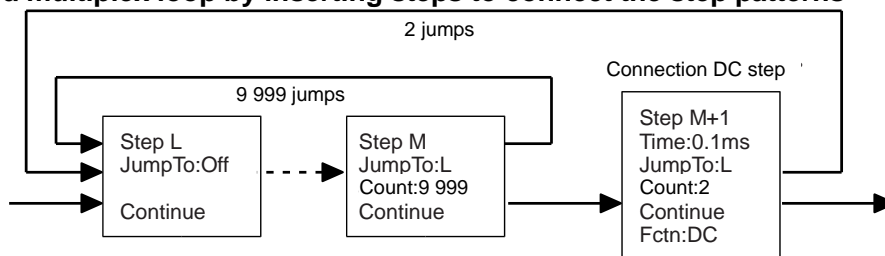

If it is not a problem to insert an appropriate pause of DC, insert a step of 0.1ms, which is the minimum length, to configure a multiplex loop. This enables the integer times repetition of the internal loop. By adding such connecting steps between the step patterns, it is possible to configure the multiplex loops for as many times as you wish. Note, however, the following points.

- At the step immediately after DC, the reference phase is initialized. (P.11-8)
- The total step time is extended for the repeated number of the steps which connect the step patterns.

## 12. Using User-defined Units

12.1	About User-defined Unit.....	12-2
12.2	Display and Setting in User-defined Unit .....	12-2
12.3	Defining User-defined Units .....	12-3

## 12.1 About User-defined Unit

For example, you can set the frequency in units of rpm (number of rotations per minute) instead of Hz. You can set a value converted to the mechanical deviation quantity or a value converted to the output voltage after the power amplifier output instead of voltage.

Defining these mutual conversion formulas enables you to use them like the usual units. In this product, these units are called "user-defined unit."

The user-defined unit can be used for the following six parameters:  
Frequency, period, amplitude, DC offset, phase, and duty

## 12.2 Display and Setting in User-defined Unit

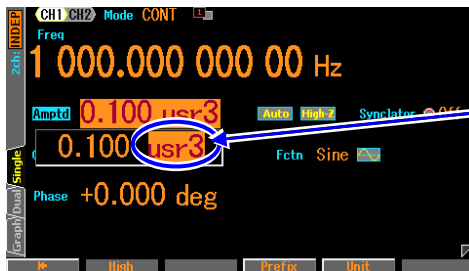

Select the  
user-defined unit

When an input field for each parameter opens, you can change the unit by putting the cursor on the unit at the right end and using the up/down arrow key or the modify knob. The unit name displayed here can be set arbitrarily. Only the display unit is changed without changing the actual output value, when the unit is changed.

## 12.3 Defining User-defined Units

### ■ Setting screen

The setting is done on the Utility screen.

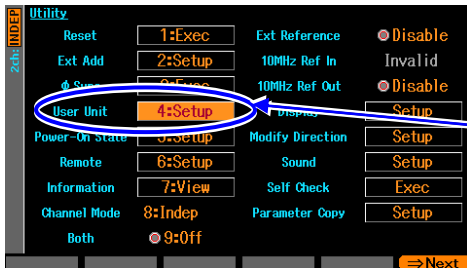

1. In the Utility screen, select the [User Unit] field and press the ENTER key.

In the Utility screen, select the [User Unit] and press the ENTER key

2. The user-defined unit setting window opens. Select each item, and then press the ENTER key to set the user-defined unit. Alternatively, you can open the input field by pressing the corresponding soft-key.

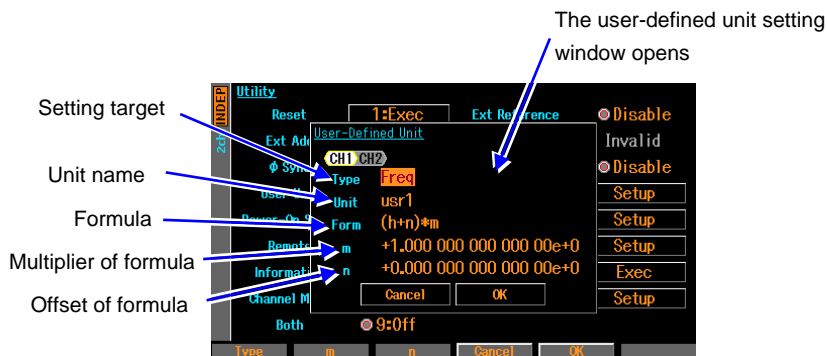

The following items can be set in this window:

Setting target [Type]

Select one from among frequency, period, amplitude, DC offset, phase, and duty.

Unit name [Unit]

Sets the unit name with up to 4 characters. Enter a character one by one at the cursor position using the up/down arrow key, the modify knob, or the numeric keypad.

Formula [Form]

Select either one of  $[(h+n)*m]$  or  $[(\log(h)+n)*m]$  as the unit conversion formula. Where, h is an original value of the setting target. The value converted by this formula is displayed on the screen when the user-defined unit is actually used.

The unit of h is defined as shown in the following table depending on the setting target:

Setting target	Unit of h
Frequency	Hz
Period	sec
Amplitude	If amplitude range is $\pm FS$ , then $V_{p-p}$ If amplitude range is $0/+FS, -FS/0$ , then $V_{pk}$ A value under the designated load impedance condition in each case
DC Offset	V A value under the designated load impedance condition
Phase	deg
Duty	%

log is a common logarithm whose base is 10. You need to pay attention to when you use a log formula for a value that can be negative such as the DC offset and phase. If a value before changing to the user-defined unit is zero (0), "-Inf" is displayed when changing to the user-defined unit using the log. Similarly, if a value before changing to the user-defined unit is negative, "Over" is displayed when changing to the user-defined unit using the log.

Multiplier and offset of formula [m], [n]

Select the multiplier m and offset n in the selected formula.

After setting each parameter, select [OK] at the bottom of the window and press the ENTER key.

**Check**  
 When you use the user-defined unit, the setting resolution may be rough depending on the setting of multiplier or offset.

■ To set the frequency in rpm

For example, to display and set the frequency in 1 Hz as the frequency in 60 rpm, set the followings and select [OK]:

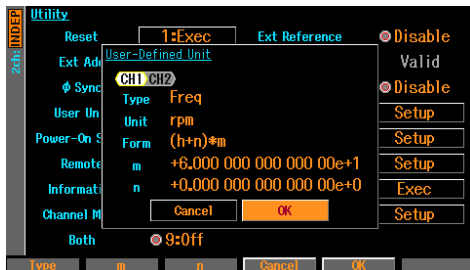

Type: Freq  
 Unit: rpm  
 Form: (h+n)\*m  
 m: 60  
 n: 0

Next, in the Oscillator screen, open the input field for the frequency, and then change the unit from Hz to rpm.

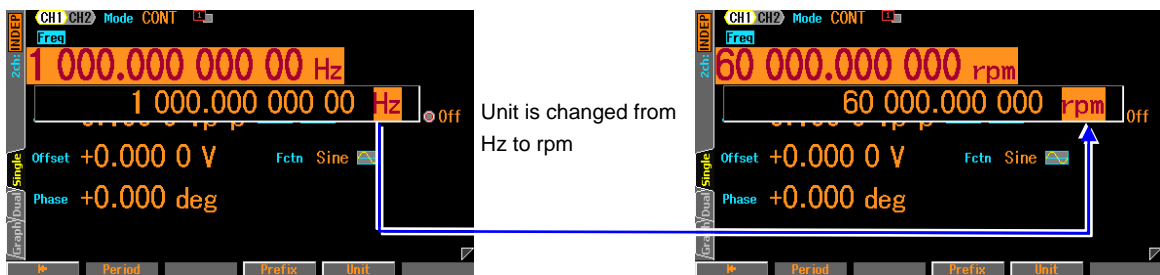

This can display and set a value in units of rpm.

## 13. Other Utility Settings

13.1	Selecting Remote Interface [Remote] .....	13-2
13.2	Display Setting [Display] .....	13-2
13.3	Modify Knob and Modify Direction Setting [Modify Direction].....	13-2
13.4	Operation Sound Setting [Sound] .....	13-3
13.5	Self-Diagnosis [Self Check] .....	13-3
13.6	Product Information Display [Information] .....	13-3

### 13.1 Selecting Remote Interface [Remote]

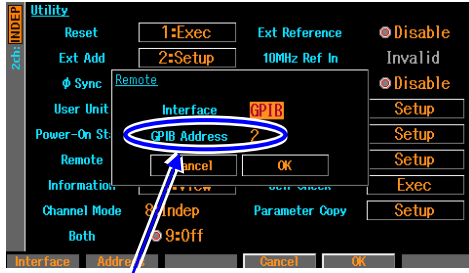

GPIB address

Select the external control interface from USB, GPIB or LAN(option).  
 When you select USB, USB ID is displayed.  
 When you select GPIB, set GPIB address within the range of 0 to 30.  
 When you select LAN, MAC address and port address are displayed. Set IP address, subnet mask, and default gateway.

USB interface and USB memory cannot be used simultaneously.

### 13.2 Display Setting [Display]

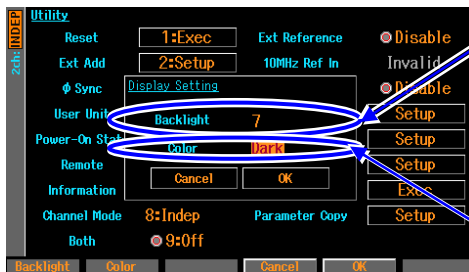

Brightness of backlight

Color tone

Set the brightness of backlight.  
 You can switch whether bright color characters are displayed on a dark background or dark color characters are displayed on a bright background as a color tone.

### 13.3 Modify Knob and Modify Direction Setting [Modify Direction]

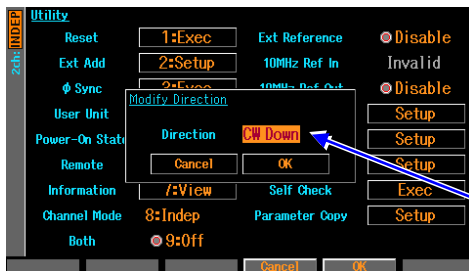

Item move direction by the clockwise turn

Select whether the item selection moves up or down when you turn the modify knob clockwise (CW) while the channel mode selection list is displayed.



### 13.4 Operation Sound Setting [Sound]

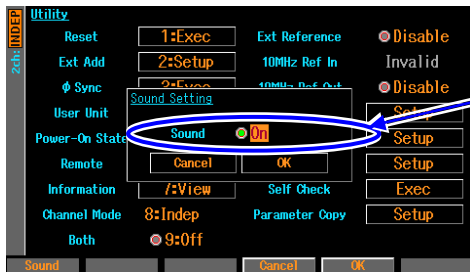

Operation sound

Set whether or not the beep sounds when performing key operations, modify knob operation, or an error occurs.

### 13.5 Self-Diagnosis [Self Check]

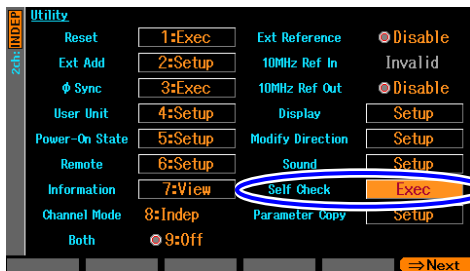

Self-Diagnosis

Self-diagnosis checks the internal status. Since the check stops the oscillation and turns off the output, it is recommended to initialize the setting by [Reset] in advance.

☞ P.4-23

Before check, remove all cables other than the power cable from this product. In rare cases, an error may occur due to the effect of noise.

If you encounter repetitive errors, please contact NF Corporation or one of our representatives.

### 13.6 Product Information Display [Information]

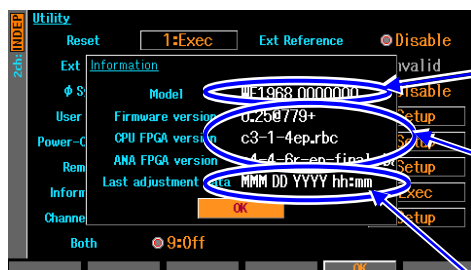

Model name

The model name, firmware version, etc. of this product are displayed.

There are no items to be set.

Firmware version

Last calibration or adjustment date

MEMO

# 14. Troubleshooting

14.1	Error Messages at Power-on .....	14-2
14.2	Error Messages during Operation .....	14-3
14.3	Conflict Messages for Modulation .....	14-7
14.4	Conflict Message for Sweep .....	14-8
14.5	Conflict Message for Burst .....	14-9
14.6	Sequence Compiler Message .....	14-10
14.7	Suspected Failure .....	14-11

## 14.1 Error Messages at Power-on

At power-on, self-diagnosis is performed and an error message is displayed if there are any problems. If you encounter any failure, please contact NF Corporation or one of our representatives. When a message that tells you machine is shut down due to overheat, check installation environment if the environment is not in hot so that the product become over heat.

Hardware initialization failed

This is an internal error. This is a failure of this instrument.

OSC-Block error

This is an internal error. This is a failure of this instrument.

RAM error

This is an internal memory error. This is a failure of this instrument.

ROM error

This is an internal memory error. This is a failure of this instrument.

Last shutdown caused by overheat

The last power-off was caused by internal overheat.

Check the operating environment and status of this instrument.

Output not turned on due to overload

The output did not become on, because overload of the synchronization/sub-output was detected even though the output settings was on at power on.

The output terminal may connect to an outer voltage supply. Check the connection. Exit the overload states before make the output turn on.

Output overload detected; Output turned off

The output became off because overload of the waveform output or synchronization/sub-output was detected even though the output settings was on at power on.

The output terminal may connect to an outer voltage supply. Check the connection. Exit the overload states before make the output turn on.

## 14.2 Error Messages during Operation

Often run-time error messages are displayed when the setting exceeds the allowable output range. For example, when a square wave is output and you try to set the frequency to 100MHz, an error is displayed and the frequency is set to the maximum frequency of square wave.

Error messages are also displayed for internal overheat and output overload.

This section describes errors displayed on the dialog window in ascending order of the error numbers.

12005: Internal overheat detected

The inside of the instrument is overheated.

The ambient temperature may be too high or the instrument may be faulty. It is recommended to turn the instrument off.

14006: Internal temperature too high; Auto-shutdown will occur

Internal overheat reached the limit. The instrument is automatically turned off.

The ambient temperature may be too high or the instrument may be faulty.

22017: Function changed to Sine by changing Channel Mode

Any of 2 channels coordination modes was selected when the waveform is noise or DC. The waveform of this channel was changed to sine wave.

22018: Mode changed to Continuous by changing Channel Mode

Any of 2 channels coordination modes was selected in the BURST mode. The mode was changed to the CONT mode.

The BUERT mode cannot be used in 2 channels coordination modes.

22019: Modulation Source changed to Internal due to Channel Mode

The modulation source was changed to the internal due to any of 2 channels coordination modes. When any of 2 channels coordination modes is selected, the modulation source is set to the internal regardless of the modulation type.

When the channel mode is 2 phases, constant frequency difference, or constant frequency ratio, the modulation source for FM and FSK is limited to internal. The other types of source are not affected by this restriction. Try to set up again. When the channel mode is DIFF, source is limited to internal regardless of the modulation type.

22020: External addition turned off by changing Channel Mode

DIFF was selected as the channel mode. Ext Add is turned to off.

External addition cannot be used in the DIFF mode.

22021: SwpMode changed to Single by changing Channel Mode

2 phases, constant frequency difference, constant frequency ratio, or differential was selected for channel mode when SwpMode was Gated, It is changed to Single sweep.

In any of 2 channels coordination modes, Gated single sweep cannot be used.

22022: Synclator turned off by changing Channel Mode

Synclator was turned off because the channel mode was changed.

22023: Mode changed to Continuous by changing Function

Waveform that does not match the current oscillation condition was selected in the MODU, SWEEP, or BURST mode. The mode is changed to the Continuous.

For example, when the waveform is changed from pulse wave to sine wave during PWM, the mode is changed to continuous because PWM is not available for sine wave.

22025: Start-locked occurred due to setting conflict

The operation setting is not adequate in the MODU, SWEEP, or BURST mode. A given oscillation cannot be started.

When pressing the soft-key [?] on the left end, the message concerning an improper item appears.

22026: SyncOut selection changed to Sync by selection of external modulation

Modulation is changed from internal to external. Synchronization/sub-output is set as reference phase synchronization (Sync).

Modulation synchronization (ModSync) and modulation waveform (ModFctn) can be selected as synchronization/sub-output for internal modulation.

- 22029: Edge time changed due to Width  
A given pulse width time cannot be achieved with the current edge time (LE, TE). The edge time becomes shorter.  
The pulse width time takes precedence over the edge time.
- 22030: Edge time changed due to Duty  
A given pulse width duty cannot be achieved with the current edge time (LE, TE). The edge time becomes shorter.  
The pulse width duty takes precedence over the edge time.
- 22031: Edge time and/or Width changed due to Frequency  
The specified frequency cannot be achieved with the current edge time (LE, TE) and pulse width time. The edge time and the pulse width time are changed.  
The Frequency takes precedence over the pulse width time and the edge time.
- 22032: Edge time and/or Duty changed due to Frequency  
The specified frequency cannot be achieved with the current edge time (LE, TE) and pulse width duty. The edge time and the pulse width duty are changed.  
The Frequency takes precedence over the pulse width duty and the edge time.
- 22034: Selected ARB is missing; Edit Memory ARB assigned  
The specified arbitrary wave does not exist. An arbitrary wave in the edit memory is assigned instead of it.  
This error happens when an arbitrary wave used before has been deleted during not used. An arbitrary wave is identified only with the number.
- 22035: Too narrow or too wide Duty specified; Amplitude may decrease or pulse may be lost  
The duty setting is too narrow or too wide. Amplitude may decrease or pulse may be lost.  
This event happens when the pulse width of a square wave with extended duty variable range is narrower than 8.4ns on the low or high side.
- 22036: Frequency reduced due to Function  
The frequency is changed to the lower value based on the waveform.  
The upper limit of frequency depends on the waveform.
- 22038: Duty changed due to Extend-Off  
The duty variable range of a square wave is changed to standard. The duty is changed to the value restricted by the frequency.  
When the duty variable range is standard, it is changes based on the frequency.
- 22039: Duty changed due to Frequency  
The duty variable range of a square wave is standard. The duty was changed to the value restricted by the frequency.  
When the duty variable range is standard, it changes based on the frequency.
- 22040: High level changed due to Low level  
The change to the low level also changes the high level based on the possible output range.
- 22041: Low level changed due to High level  
The change to the high level also changes the low level based on the possible output range.
- 22042: Not acceptable due to another CH limitation  
The specified setting cannot be set due to another channel restriction in 2-channel equivalence setting.
- 22043: Frequency and/or DeltaFreq changed due to Function  
The frequency and the frequency difference are changed based on the upper frequency of waveform when the channel mode is DIFF.
- 22044: Frequency of CH1 changed due to DeltaFreq  
The frequency of CH1 is changed to maintain the frequency difference when the channel mode is DIFF.  
The frequency difference takes precedence over the frequency of CH1.

22045: Frequency changed due to Function

The frequency is changed based on the upper frequency of waveform when the channel mode is RATIO.

22046: Frequency of CH1 changed due to Ratio

The frequency of CH1 is changed to maintain the frequency ratio when the channel mode is RATIO. The frequency ratio takes precedence over the frequency of CH1.

22047: Output not turned on due to overload

Overload is detected in synchronization/sub-output. The output did not become on. The output terminal may connect to an outer voltage supply. Check the connection. Exit the overload states before make the output turn on.

22048: Synclator turned off due to ModuType:FSK/PSK/FM

The modulation type was changed to FSK/PSK/FM. The synclator was turned off.

22149: Modulation Source of CH2 changed to Internal by changing CH1 or CH2 setting

The modulation source of CH2 was set to CH1 external for FSK or PSK. The modulation source of CH2 was changed to the internal due to the setting change of CH1 or CH2. The CH2 modulation source can be set to CH1 external only if CH1 and CH2 are same types and external is selected as the modulation source of CH1.

22150: Trigger of CH2 changed to Internal by changing CH1 or CH2 setting

The trigger source of CH2 was set to CH1 external for SWEEP or BURST. The trigger source of CH2 was changed to the internal due to the setting change of CH1 or CH2. The trigger source of CH2 can be set to CH1 external only when external is selected as the trigger source of CH1 in the following conditions.

- CH1 and CH2 have the same sweep type. CH1 and CH2 are in the same sweep mode (except for Cont).
- CH1 and CH2 are in the same burst mode (except for auto burst).

23045: Data out of range; Data discarded

You tried to enter a value outside of setting range. The value entered is discarded.

23133: MOD/ADD IN connector used by external addition now

The MOD/ADD IN connector is used for external addition. Cannot use it with external modulation at a time.

23134: MOD/ADD IN connector used by external modulation now

The MOD/ADD IN connector is used for external modulation. Cannot use it with external addition at a time.

23137: Output overload detected; Output turned off

Overload was detected in waveform output or synchronization/sub-output. The output was turned off. The output terminal may connect to an outer voltage supply. Check the connection. Exit the overload states before make the output turn on.

23138: Self Check failed; Auto-shutdown will occur

The result of the self check failed. Turn the power on/off. The instrument may have a failure.

32004: Not able to delete this ARB; This ARB is in current use

An arbitrary wave that is currently output or used cannot be deleted. In the MODU mode, an arbitrary waveform that is used as an internal modulation wave cannot be deleted.

35005: File-system error

This is an internal error. This is a failure of this instrument.

60002: ARB waveform under editing not stored; Shutdown?

The arbitration waveform being edited has not been stored yet. It will be cleared when the power turns off. Store it as needed.

61056: Data beyond lower limit; Value clipped to lower limit

You are trying to set the value beyond lower limit. The value is set to the lower limit.

61057: Data beyond upper limit; Value clipped to upper limit

You are trying to set the value beyond upper limit. The value is set to the upper limit.

61058: Zero data not allowed

Zero cannot be set in this parameter.

61059: Invalid operation

This operation is invalid. You are trying to insert a control point into the impossible place while editing arbitration wave.

61060: Invalid operation

This operation is invalid. You are trying to delete a control point that cannot be deleted while editing an arbitrary wave.



---

## 14.3 Conflict Messages for Modulation

These messages are displayed when the [?] soft key is pressed when the specified modulation cannot be executed due to an inappropriate setting (conflict state). They describe the improper settings.

**HopFreq beyond upper limit for current Function**

The hop frequency is beyond the allowable range of the current waveform to output in FSK.

Lower the hop frequency.

**MOD/ADD IN connector used by external addition now**

The MOD/ADD IN connector is currently used for external addition. It cannot be used for external modulation.

Turn the external addition function off.

**Modulated peak or bottom value out of range**

[The carrier value + the deviation] or [the carrier value - the deviation] is beyond the allowable range to output in FM, PM, OFSM, PWM.

Change the carrier value or make the deviation low.

**Modulated peak or bottom phase out of range**

[The carrier value + the deviation] is beyond the allowable range to output in PSK.

Change the carrier value or make the deviation low.

**Modulation Type not compatible with current Function**

The modulation type is not adequate for the current waveform. For example, PWM is specified for the sine wave.

Change the modulation type.

## 14.4 Conflict Message for Sweep

These messages are displayed when the [?] soft key is pressed when the specified sweep cannot be executed due to an inappropriate setting (conflict state). They explain about the improper settings.

### Frequency beyond upper limit for Gated sweep

The frequency is beyond the upper frequency of gated sweep.  
Lower the frequency.

### Gated sweep not available for DC

Gated sweep is not available for DC waveform.  
Change the sweep mode to continuous or single.

### Start value out of range

The start value is beyond the allowable range to output.  
Change the value so that it falls within the range.

### Stop value out of range

The stop value is beyond the allowable range to output.  
Change the value so that it falls within the range.

### Sweep Type not compatible with current Function

The sweep type is not adequate for the current waveform. For example, duty sweep is specified for the sine wave.  
Change the sweep type.

## 14.5 Conflict Message for Burst

These messages are displayed when the [?] soft key is pressed when the specified burst cannot be executed due to an inappropriate setting (conflict state). They describe the improper settings.

### BrstMode not compatible with current Function

The burst oscillation mode is not adequate for the current waveform. For example, trigger burst is specified for noise.

Change the burst oscillation mode.

### Frequency beyond upper limit for current Function

The frequency is beyond the upper frequency of the current waveform.

Lower the frequency.

## 14.6 Sequence Compiler Message

These messages are displayed when unexecutable setting is found as a result of sequence compilation.

Amptd-Offset conflict

CH:N Step:M

Amptd (Step K) - Offset (Step L)

The amplitude and offset do not satisfy mutual restriction in step M of channel N. The amplitude is set at step K and the offset is set at step L.

Lower the amplitude or offset.

Fctn-Freq conflict

CH:N Step:L-M

The frequency exceeds the upper limit for the waveform between step L and step M of channel N.

Lower the frequency.

Fctn-Freq-Duty conflict

CH:N Step:M

Freq (Step K) - Duty (Step L)

The frequency and duty of the square wave do not satisfy mutual restriction in step M of channel N. The frequency is set at step K and the duty is set at step L.

Lower the frequency or bring the duty close to 50%.

Selected ARB is missing

CH:N Step:M

The arbitrary wave specified at step M of channel N does not exist.

Specify another arbitrary wave.

Selected ARB loading failed

CH:N Step:M

The arbitrary wave could not be read in at step M of channel N.

This is an internal error. This is a failure of this instrument.

Too complex to check

The sequence was too complex to be checked.

Simplify the sequence structure.

Too many or too large Functions used

The number of waveforms used exceeds 128 or the total exceeds 1MiW.

Reduce the number of waveforms. Or reduce the number of data points of the arbitrary wave in the array format. ☞ P.11-10

## 14.7 Suspected Failure

When the device appears to be abnormal, try following steps. If the operations cannot be recovered after the measures taken, contact NF Electronic Instruments or one of its representatives.

Problem	Possible cause	Action	Reference page
The power does not turn on	The power supply out of rated range is used.	Use the power supply within the rated range.	"2.3 Grounding and power supply connection" P. 2-5
	The operation is not normal due to external noise, etc.	Install the instrument in quiet environment far from noise sources.	"2.2 Installation" P. 2-3
The panel is not available	In the Remote state	Change to the Local state	-
	keys and/or modify knobs are deteriorated	Contact NF Electronic Instruments to ask repair	-
Output level is Abnormal	The ambient temperature/humidity range is out of the performance guaranteed range.	Use in the environment within the specified range.	"2.2 Installation" P. 2-3
	Warming up is not enough	Perform warming up for more than 30 minutes after the power turns on	-
	DC offset is added	Make the DC offset to 0V	"4.4.9 To Set DC Offset" P. 4-35
	A user-defined unit is used	Select a standard unit	"4.4.8 To Set Amplitude" P. 4-33
	The load impedance function is used	Change the setting to Hi-Z	"4.4.13 To Set Load Impedance" Page 4-41
Settings with the remote control are not available.	The interface setting is not adequate.	Use the setting that matches the interface to use.	"13.1 Selecting Remote Interface" P. 13-2
	The GPIB address, the USB ID, or settings of LAN is different from the program.	Make the GPIB address, the USB ID, or setting of LAN match the program.	
	The same GPIB address as that of other devices is used	Set the GPIB address again so that it does not coincide with that of other devices.	
Self-diagnosis identified an error	A malfunction occurred due to external noise	Remove all cables other than the power cable from the device and perform the self-diagnosis again.	"13.5 Self-Diagnosis" P. 13-3
Does not become same as described in Instruction manual	Initialization has not been done.	Description presumes settings were initialized. Perform initialization.	"4.3.8 To Restore Initial Settings" P. 4-23
	The channel to operate is opposite.	Check whether the channel is CH1 or CH2.	"4.3.6 CH1/CH2 Switching Key and Active Channel (WF1968 Only)" P. 4-20

MEMO

# 15. Maintenance

15.1	Outline .....	15-2
15.2	Operation Inspection.....	15-4
15.3	Performance Test.....	15-5

---

## 15.1 Outline

### ■ What TO DO

To use the instrument under the best condition, following maintenance tasks are needed.

- Operation inspection      Check to see if the equipment is operating correctly.
- Performance test          Check to see if the equipment satisfies the ratings.
- Adjustment and calibration      If any rating is not satisfied, NF Corporation will perform adjustment or calibration to recover the performance.
- Fault repair                      If this fails to remedy the problem, NF Corporation will investigate the cause of the problem and repair it.

This Instruction Manual describes the operation inspection and the performance testing method that can be easily performed.

For more accurate inspections, adjustments, calibration or repairs, contact NF Corporation or one of our representatives.

---

### **WARNING**

High voltages appear inside of the instrument. Never remove the cover.

No one except the trained service technicians who are thoroughly experienced in the hazard prevention is allowed to check or touch the inside of this instrument. Do not touch the inside by yourself in any case.

---



## ■ Equipment

To perform the operation inspection and performance test, following instruments.

	Requirement	Sample Model	Intended Purpose
Digital Multi-meter	AC Voltage TrueRMS Accuracy: $\pm 0.1\%$ (1kHz to 100kHz) DC voltage Accuracy: $\pm 0.1\%$	Agilent 3458A	Measurement of AC voltage less than 100kHz, and DC voltage.
Power meter and Power sensor	100kHz to 30MHz 5 $\mu$ W to 250mW (-23dBm to +24dBm) Accuracy: 0.02dB Resolution: 0.01dB	R&S NRVD, NRV-Z5	Measurement of AC voltage more than 100kHz
Universal Counter	Accuracy: 0.1ppm	Agilent 53131A Opt 010 (highly-stabilized TB)	Measurement of frequency, duty, time interval between channels
Oscilloscope	BW 300MHz or greater 2GS/s, 50 $\Omega$ input	Agilent DSO6032A	Measurement of rising and falling time
Audio Analyzer	THD measurement, fullscale is 0.01% or better.	Panasonic VP-7722A	Harmonic distortion measurement
Spectrum Analyzer	10kHz to 1GHz RBW: 100Hz	Agilent E4411B Opt 1DR (Narrow RBW)	Measurement of non-harmonic spurious
BNC cable	Characteristics impedance: 50 $\Omega$ Length: 1m, 30cm		-
BNC(f)- banana adapter	-	-	
BNC(f)-N(m) adapter	Characteristics impedance: 50 $\Omega$		To Connect a BNC cable to a spectrum analyzer
BNC(f)-N(f) adapter	Characteristics impedance: 50 $\Omega$	-	To Connect a BNC cable to a power sensor

## 15.2 Operation Inspection

### ■ Check Before Operation inspection

Check followings before the operation inspection.

- The power supply voltage is within the rated range.
- Ambient temperature is within the range of 0 to +40°C.
- Ambient relative humidity is within the range of 5 to 85%RH (furthermore, the absolute humidity is within the range of 1 to 25g/m<sup>3</sup>).
- Non-condensing.

### ■ Function check

#### ● Check at power-on

Make sure that no error message appears at power-on.

When an error message appears, [☞ P. 14-2](#).

When the display shows any problems at the power-on, turn the power off, wait for at least 5 seconds and turn the power-on again.

#### ● Self-diagnosis

Perform Self Check on the Utility screen.

[☞ P.13-3](#)

#### ● Check of important functions

To avoid miss-setting, perform initialization first (Perform [Reset] in the Utility screen).

Then, connect the FCTN OUT to the oscilloscope using characteristic impedance 50Ω series coaxial cable and observe the output.

Change following settings several times and check they work properly. For items that set numeric values like the frequency, check become more reliable by operating both a numeric keypad and modify knobs.

- Waveform (shortcut key: FCTN key **FCTN**)
  - Frequency (shortcut key: FREQ key **FREQ**)
  - Amplitude (shortcut key: AMPD key **AMPD**)
  - DC offset (shortcut key: OFFSET key **OFFSET**)
  - Output on/off (**CH 1**, **CH 2**, or **OUTPUT**)
- #### ● Check of GPIB, USB and LAN(Optional)
- Perform some of setting changes performed in the check of important function section on the GPIB, USB and LAN. Verify that Changes of the output is the same.
- In this case, GPIB, USB or LAN is displayed on the status display area on the top of the screen. Check also that pressing the [Local] soft key while GPIB, USB or LAN is displayed on the status display area clears the previous status display and returns to the local status (except for during local lockout condition).

## 15.3 Performance Test

### ■ Performance Test

The performance test is performed as a part of preventive maintenance to prevent the product performance from being deteriorated.

Perform the performance test when an acceptance inspection, a periodic inspection, or a performance check after repair of this product is needed.

After the performance test, when the product does not meet the specification, it needs to be repaired.

Contact NF Corporation or one of our representatives.

### ■ Check before the performance test

Check followings before the performance test.

- The power supply voltage is within the rated range.
- Ambient temperature is within the range of +20 to +30°C.
- Ambient relative humidity is within the range of 20 to 70%RH.
- Non-condensing.
- Warming up was performed for more than 30 minutes.

### ■ Preparations before performance test

- Use a coaxial cable whose characteristic impedance is 50Ω, thickness is RG-58A/U or more, and length is 1m or less, and has BNC connectors on both ends as a signal cable.
- For items that 50Ω termination is specified, set the input impedance for connecting instruments to 50Ω.
- For instruments that cannot be set to 50Ω input, install 50Ω terminator (feed through terminator) at the input of the instrument.
- Measure a signal up to approx. 24dBm (when the amplitude setting is 20Vp-p/open). Use a coaxial attenuator separately as needed not to exceed the allowable input of the instrument. Note that especially the power meter (power sensor) and the spectrum analyzer are damaged easily.
- The setting contents for each test item contains the descriptions of items which should be further changed after initializing the setting (perform [Reset]) in the Utility screen) and turning the output on.

### 15.3.1 Frequency Accuracy Test

Connection: FCTN OUT → Universal counter input (50Ω termination)

Use a coaxial cable.

Setting: Set the frequency to 1MHz and the amplitude to 10Vp-p/open after setting initialization.

Measurement: Set the universal counter to the frequency measurement mode and measure the frequency.

Judgment: It is normal when the value falls within the following.

However, the instrument may vary  $\pm 1$ ppm annually over the years. Therefore, if one year has passed since the instrument was shipped, it may be deteriorated within  $\pm 4$ ppm (999.996kHz to 1.000004MHz).

Rating range
0.999997MHz to 1.000003MHz

### 15.3.2 Sine Wave Amplitude Accuracy Test

- Connection: FCTN OUT → Digital multi-meter (AC voltage TrueRMS measurement)  
Use a coaxial cable.
- Setting: The following table shows the amplitude after setting initialization. (Frequency is set to 1kHz).
- Measurement: Measure the output voltage for each waveform as the effective value.
- Judgment: It is normal when the value falls within the following table.

Amplitude setting (load open value)	Rating range
20Vp-p (7.071Vrms)	7.000Vrms to 7.142Vrms
5Vp-p (1.768Vrms)	1.749Vrms to 1.786Vrms
3Vp-p (1.061Vrms)	1.049Vrms to 1.072Vrms
1Vp-p (353.6mVrms)	349.3Vrms to 357.8mVrms
0.3Vp-p (106.1mVrms)	104.3mVrms to 107.8mVrms
0.1Vp-p (35.36mVrms)	34.29mVrms to 36.42mVrms
0.02Vp-p (7.071mVrms)	6.293mVrms to 7.849mVrms

### 15.3.3 DC Offset Accuracy Test

#### ■ DC only

- Connection: FCTN OUT → Digital multi-meter (DC voltage measurement)
- Setting: Set the waveform to DC after setting initialization. The following table shows the DC offset.
- Measurement: Measure the output voltage as DC.
- Judgment: It is normal when the value falls within the following table.

DC offset setting (load open value)	Rating range
±10V	±9.890V to ±10.110V
±3V	±2.960V to ±3.040V
±1V	±0.9800V to ±1.0200V
±0.3V	±0.2870V to ±0.3130V
0V	-10.00mV to +10.00mV

#### ■ AC+DC

- Connection: FCTN OUT → Digital multi-meter (DC voltage measurement)
- Setting: Set the oscillation mode to BURST, burst mode to GATE, trigger to external Off (the oscillation of sine wave is stopped at 0 degree) after setting initialization.  
The following table shows the amplitude. DC offset setting is left to 0 V.
- Measurement: Measure the output voltage as DC.
- Judgment: It is normal when the value falls within the following table.

Amplitude setting (load open value)	Rating range
6.4Vp-p	-42.00mV to +42.00mV
3.5Vp-p	-27.50mV to +27.50mV
0.7Vp-p	-13.50mV to +13.50mV

### 15.3.4 Sine Wave Amplitude/Frequency Characteristics Test

■ **100kHz or lower**

Connection: FCTN OUT → Digital multi-meter (AC voltage TrueRMS measurement, and 50Ω termination)

Use a coaxial cable.

Setting: The following table shows the amplitude and frequency after setting initialization.

Measurement: Measure the output voltage for each frequency as the effective value.

Judgment: For each amplitude setting, it is normal when the measurement error for each frequency based on the measurement values at 1kHz falls within the range of the following table. (The line at right end of the table is used in the next section.)

Amplitude setting (Value at 50Ω load)	Measured value at 1kHz	Error at 50kHz	Error at 100kHz	Error of each amplitude at 100kHz is as follows.
10Vp-p	Reference value	±0.1dB	±0.1dB	X1 (dB)
2.5Vp-p	Reference value	±0.1dB	±0.1dB	X2 (dB)
2.0Vp-p	Reference value	±0.1dB	±0.1dB	X3 (dB)
0.5Vp-p	Reference value	±0.1dB	±0.1dB	X4 (dB)
0.15Vp-p	Reference value	±0.1dB	±0.1dB	X5 (dB)
0.05Vp-p	Reference value	±0.1dB	±0.1dB	X6 (dB)

■ More than 100kHz

Connection: FCTN OUT → Power meter (Power sensor)  
 Use a coaxial cable. Measure a signal up to approx. 24dBm. Use a coaxial attenuator separately not to exceed the allowable input of the power sensor.

Setting: The following table shows the amplitude and frequency after setting initialization.

Measurement: Measures the output voltage or the power at each frequency.

Judgment: For each amplitude setting, it is normal when the measurement error for each frequency based on the measurement values at 100kHz falls within the range of the following table.  
 Add the error  $X_n$  ( $n=1-6$ ), previously measured at 100kHz by the digital multi-meter, to the judgment range.  
 For example, when  $X_1$  is  $-0.05\text{dB}$ , the judgment range at  $10\text{Vp-p}$  and  $5\text{MHz}$  is  $-0.1\text{dB}$  to  $0.2\text{dB}$ .

Amplitude setting (Value at 50Ω load)	Measured value at 100kHz	Error at 1MHz	Error at 5MHz	Error at 10MHz
10Vp-p	Reference value	$-X_1 \pm 0.15\text{dB}$	$-X_1 \pm 0.15\text{dB}$	$-X_1 \pm 0.2\text{dB}$
2.5Vp-p	Reference value	$-X_2 \pm 0.15\text{dB}$	$-X_2 \pm 0.15\text{dB}$	$-X_2 \pm 0.2\text{dB}$
2.0Vp-p	Reference value	$-X_3 \pm 0.15\text{dB}$	$-X_3 \pm 0.15\text{dB}$	$-X_3 \pm 0.2\text{dB}$
0.5Vp-p	Reference value	$-X_4 \pm 0.15\text{dB}$	$-X_4 \pm 0.15\text{dB}$	$-X_4 \pm 0.2\text{dB}$
0.15Vp-p	Reference value	$-X_5 \pm 0.15\text{dB}$	$-X_5 \pm 0.15\text{dB}$	$-X_5 \pm 0.2\text{dB}$
0.05Vp-p	Reference value	$-X_6 \pm 0.15\text{dB}$	$-X_6 \pm 0.15\text{dB}$	$-X_6 \pm 0.2\text{dB}$

Amplitude setting (Value at 50Ω load)	Measured value at 100kHz	Error at 20MHz	Error at 50MHz	Error at 100MHz	Error at 200MHz
10Vp-p	Reference value	$-X_1 \pm 0.2\text{dB}$	$-X_1 \pm 0.5\text{dB}$	$-X_1 \pm 0.7\text{dB}$	-----
2.5Vp-p	Reference value	$-X_2 \pm 0.2\text{dB}$	$-X_2 \pm 0.5\text{dB}$	$-X_2 \pm 0.7\text{dB}$	-----
2.0Vp-p	Reference value	$-X_3 \pm 0.2\text{dB}$	$-X_3 \pm 0.5\text{dB}$	$-X_3 \pm 0.7\text{dB}$	$-X_3 \pm 0.8\text{dB}$
0.5Vp-p	Reference value	$-X_4 \pm 0.2\text{dB}$	$-X_4 \pm 0.5\text{dB}$	$-X_4 \pm 0.7\text{dB}$	$-X_4 \pm 0.8\text{dB}$
0.15Vp-p	Reference value	$-X_5 \pm 0.2\text{dB}$	$-X_5 \pm 0.5\text{dB}$	$-X_5 \pm 0.7\text{dB}$	$-X_5 \pm 0.8\text{dB}$
0.05Vp-p	Reference value	$-X_6 \pm 0.2\text{dB}$	$-X_6 \pm 0.5\text{dB}$	$-X_6 \pm 0.7\text{dB}$	$-X_6 \pm 0.8\text{dB}$

**15.3.5 Sine Wave Total Harmonic Distortion Test**

- Connection: FCTN OUT → Audio analyzer (50Ω termination)  
 Use a coaxial cable. If the audio analyzer does not have a 50Ω termination, install a 50Ω terminator (feed through terminator) at the input of the instrument.
- Setting: Set frequency to 20kHz after setting initialization. The following table shows the amplitude.
- Measurement: Measure the harmonic distortion up to the 7th order THD<sub>7</sub>(%). (Not THD + N)  
 When THD<sub>7</sub> cannot be measured directly, measure the harmonic distortion from the 2nd order to the 7th order (HD<sub>2</sub>~HD<sub>7</sub>)(%) and obtain THD<sub>7</sub> (%) through calculation.

$$THD_7 = \sqrt{HD_2^2 + HD_3^2 + HD_4^2 + HD_5^2 + HD_6^2 + HD_7^2}$$

Judgment: It is normal when the value falls within the following table.

Amplitude setting (Value at 50Ω load)	Total harmonic distortion (THD <sub>7</sub> )
1Vp-p	0.04 % or lower

**15.3.6 Sine Wave Harmonic Spurious Test**

- Connection: FCTN OUT → Spectrum analyzer  
 Use a coaxial cable. Measure a signal up to approx. 24dBm. Use a coaxial attenuator separately not to exceed the allowable input of the spectrum analyzer.
- Setting: The following table shows the amplitude and frequency after setting initialization.
- Measurement: Measure the harmonic spurious up to the 5th order and obtain the total value of harmonic spurious through calculation.  
 Make an attenuator of spectrum analyzer high until the relative level of the fundamental wave is stable.  
 Using X2 to X5 (dBc) as the relative values of the harmonic spurious up to the 5th order based on the fundamental wave, the total harmonic spurious can be obtained with the following formula.

$$HarmonicSpurious = \sqrt{10^{\frac{X2}{10}} + 10^{\frac{X3}{10}} + 10^{\frac{X4}{10}} + 10^{\frac{X5}{10}}}$$

Judgment: It is normal when the value falls within the following table.

Amplitude setting (Value at 50Ω load)	Total value of the maximum harmonic spurious level up to the 5th order			
	Frequency setting 1MHz	Frequency setting 5MHz	Frequency setting 30MHz	Frequency setting 200MHz
1Vp-p	-60dBc or less	-50dBc or less	-40dBc or less	-30dBc or less

### 15.3.7 Sine Wave Non-harmonic Spurious Test

- Connection: FCTN OUT → Spectrum analyzer  
Use a coaxial cable. Measure a signal up to approx. 24dBm. Use a coaxial attenuator separately not to exceed the allowable input of the spectrum analyzer.
- Setting: The following table shows the amplitude and frequency after setting initialization.
- Measurement: Measure the max value of the non-harmonic spurious.
- Judgment: It is normal when the value falls within the following table.

Amplitude setting (Value at 50Ω load)	Maximum non-harmonic spurious level		
	Frequency setting 8MHz	Frequency setting 80MHz	Frequency setting 200MHz
2Vp-p	-55dBc or less	-35dBc or less	-35dBc or less

### 15.3.8 Square Wave Duty Accuracy Test

- Connection: FCTN OUT → Universal counter (50Ω termination)  
Use a coaxial cable.
- Setting: Set the waveform to square and the amplitude to 20Vp-p/open after setting initialization. The following table shows the duty variable range setting, the frequency setting, and the duty setting.
- Measurement: Set the universal counter to duty measurement mode. Set the trigger level of the universal counter to 0V. Average the measured values because they vary due to jitter (especially when the duty variable range is extend).
- Judgment: It is normal when the value falls within the following table.

#### ■ Duty variable range standard

Frequency	Duty		
	When 1% is set 0.9% to 1.1%	When 50% is set 49.9% to 50.1 %	When 99% is set 98.9% to 99.1%
300kHz	When 5% is set 4% to 6%	When 50% is set 49 % to 51 %	When 95% is set 94% to 96%
3MHz	When 40% is set 37% to 43%	When 50% is set 47% to 53%	When 60% is set 57% to 63%

#### ■ Duty variable range extend

Frequency	Duty		
	When 1% is set 0.9% to 1.1%	When 50% is set 49.9% to 50.1%	When 99% is set 98.9% to 99.1%
300kHz	When 5% is set 4% to 6%	When 50% is set 49% to 51%	When 95% is set 94% to 96%
3MHz	When 40% is set 37% to 43%	When 50% is set 47% to 53%	When 60% is set 57% to 63%



### 15.3.9 Square Wave Leading/Trailing Time Test

- Connection: FCTN OUT → Oscilloscope (50Ω termination)  
Use a coaxial cable.
- Setting: Set the waveform to square, the frequency to 5MHz, and the amplitude to 4Vp-p/open after setting initialization.  
The following table shows the duty variable range.
- Measurement: Observe the waveform and measure the leading and trailing time.
- Judgment: It is normal when the value falls within the following table.

Duty variable range	leading time, trailing time
Standard	4.6ns or less
Extended	4.6ns or less

### 15.3.10 Time Difference Between Channels for 2-Phase (WF1968 Only)

- Connection: CH1 FCTN OUT → Universal counter input 1 (50Ω termination)  
CH2 FCTN OUT → Universal counter input 2 (50Ω termination)  
Use coaxial cables whose length and kind are same.
- Setting: Set the channel mode to 2PHASE, amplitude to 20Vp-p/open, phase of CH2 to 180deg, and frequency to 10MHz after setting initialization. The following table shows the waveform.  
The measurement is performed by setting the phase difference to 180 deg. This is because the normal counter cannot measure a negative time difference. With this setting, a fixed offset time can be provided.
- Measurement: Measure the interval between CH1 and CH2 by setting the universal counter to the time interval mode of input 1 → input 2. Set the trigger level of the universal counter to 0V and the trigger polarity to rising for CH1 and CH2. Measured values vary. Average them.
- Judgment: It is normal when the value falls within the following table.

Waveform	Rating range
Sine Wave	50ns ± 20ns
Square wave (duty variable range standard)	50ns ± 20ns
Square wave (duty variable range extend)	50ns ± 20ns

---

MEMO

## **16. List of Initial Settings**



---

**■ Sweep**

Sweep type	Frequency
Frequency sweep range	1kHz to 10kHz
Phase sweep range	-90° to 90°
Amplitude sweep range	0.1Vp-p to 0.2Vp-p
DC offset sweep range	-0.1V to 0.1V
Duty sweep range	40% to 60%
Sweep time	0.1sec
Sweep mode	Continuous
Trigger source	Internal, 1sec
External trigger input polarity	Negative
Sweep function	One way, linear
Each marker value	5kHz, 0°, 0.15Vp-p, 0V, 50%
Stop level	Off, 0%
External control input	Disabled
Oscillation stop unit when gated single	Cycle
Synchronization/sub-output	Sweep synchronization, marker on

**■ Burst**

Burst mode	Trigger burst
Mark wave number	1.0
Space wave number	1.0
Trigger source	Internal, 10msec
External trigger input polarity	Negative
Trigger delay	0s
Stop level	Off, 0%
Oscillation stop unit at gate	Cycle
Synchronization/sub-output	Burst synchronization

**■ Synclator**

Synclator	Off
Trigger source	External
External trigger input polarity	Positive

**■ 2Channel Coordination (WF1968only)**

Channel mode	Independent
Frequency difference	0Hz
Frequency ratio	1:1
Same value setting	Off

---

**■ Others**

Use of user-defined unit	Cancel
External 10MHz frequency reference input	Disable
External 10MHz frequency reference output	Disable
External addition	Off

Followings are shipping settings that are not changed with initialization.

**■ Definition of user-defined unit**

Unit name	usr1 to usr6
Formula	(h+n)*m
m	1
n	0

**■ Output setting at power-on, panel operation settings**

Output at power-on	Off
Display	Dark color
Modify direction	Downward by turning CW
Operation sound	On

Following items are initialized every time the power is turned on.

**■ Sequences**

Start step	1
Trigger polarity	Off
External control input	Disabled
External control start/state branch	Start
Synchronization/sub-output	Step synchronization
Step time	1s
Auto hold	Off
Jump destination	Off
Jump count	Infinite
Stop phase	Off
State branch	Off
Event branch	Off
Control at step terminate	Moving to the next step
Step code	LLLL
Intra-step operation	Constant
Channel parameter	Equal to the initial value

## 17. Specifications

17.1	Oscillation Mode .....	17-2
17.2	Waveform.....	17-2
17.3	Frequency, Phase .....	17-3
17.4	Output Characteristics .....	17-4
17.5	Signal Characteristics .....	17-7
17.6	Modulated Oscillation Mode.....	17-11
17.7	Sweep Oscillation Mode .....	17-14
17.8	Burst Oscillation Mode .....	17-18
17.9	Synclator Function .....	17-19
17.10	Trigger.....	17-20
17.11	Sequences.....	17-21
17.12	Other I/Os .....	17-22
17.13	2-Channel Coordination (WF1968 only).....	17-23
17.14	Synchronization of Multiple Units.....	17-25
17.15	User-defined Unit.....	17-26
17.16	Other Functions .....	17-26
17.17	Option .....	17-27
17.18	General Characteristics .....	17-27

Numeric values marked as \*1 are guaranteed values. The other numeric values are not guaranteed values but nominal values or typical values (marked as typ.).

If not specified, the condition is that oscillation is continuous, the load is 50Ω, the amplitude setting is 10Vp-p/50Ω, the DC offset setting is 0V, the auto range, the amplitude range of waveform is ±FS, the external addition is off, and AC voltage is effective value measurement.

## 17.1 Oscillation Mode

Continuous, modulated, burst, sweep, sequence

In the burst oscillation mode, modulation function is available

In the sweep oscillation mode, external modulation function is available

## 17.2 Waveform

### 17.2.1 Standard Waveform

Types	Sine, square, pulse, ramp, parameter-variable(only main output), noise (gauss distribution), DC
Polarity(only main-output)	Normal, invert (Switch) Except for DC
Amplitude range(only main-output)	-FS/0, ±FS, 0/+FS (switch) Except for DC

### 17.2.2 Arbitrary Waveform

Waveform length	Number of control points 2 to 10,000 or 4Ki to 1Mi words ( $2^n$ , $n=12$ to 20, main-output) Remarks: Linear interpolation is performed between control points. When output from the sub-output can be interpolated or decimated to be the 8ki word. (Ki and Mi represent $2^{10}=1024$ and $2^{20}=1048576$ , respectively. IEC 60027-2/IEEE 1541-2002).
Total amount of saved waveforms	Maximum 128 waves or 4Mi words (CH1 and 2 common) Waveforms can be saved in the built-in non volatile memory or external USB flash memory.
Resolution of waveform data amplitude	16bit
Sampling rate	420MS/s
Polarity	Normal, invert (Switch)
Amplitude range	-FS/0, ±FS, 0/+FS (switch)
Output bandwidth	87MHz -3dB



## 17.3 Frequency, Phase

Targets are signals output to the main-output (FCTN OUT) and signals output to the sub-output (SYNC/SUB OUT), when the sub-waveform is selected.

### 17.3.1 Frequency

Frequency setting range

Limited to the range determined by the waveform output from the main-output or from the sub-output when the sub-waveform is selected, whichever is smaller.  
When the synclator function is enabled, available frequency range of oscillation is limited to 20Hz to 10MHz.

Oscillation mode Waveform	Continuous, modulated, Sweep (continuous and single)	Sweep (gated single), Burst, Sequence
Sine Wave	0.01μHz to 200MHz * <sup>2</sup>	0.01μHz to 100MHz
Square wave	0.01μHz to 70MHz	
Pulse wave	0.01μHz to 70MHz * <sup>3</sup>	
Ramp wave	0.01μHz to 20MHz * <sup>4</sup>	
Parameter-variable waveform	0.01μHz to 20MHz * <sup>5</sup>	
Noise	Equivalent bandwidth: Select from 100M/30M/10M/3M/1M/300k/100kHz	
DC	Frequency setting is invalid	
Arbitrary waveform	0.01μHz to 20MHz	

\*2) When the upper limit exceeds 160MHz, for modulation, only external modulation is available for FM, FSK, AM and AM(SC).

For sweep, only frequency sweep and amplitude sweep are available.

\*3) Not available for sequence.

\*4) For sub-waveform, symmetry 0%, 50% and 100% only.

\*5) For sequence, this is used by converting into an arbitrary waveform. It cannot use for sub-waveform.

Frequency setting resolution

0.01μHz (< 50MHz), 0.1μHz (50MHz ≤)

Frequency setting with a period

Setting with frequency that is inverse number of set period  
Less than 0.01μHz is rounded half up

Frequency accuracy at shipping time\*<sup>1</sup>

±(3ppm of setting + 6pHz)

Frequency aging rate\*<sup>1</sup>

±1ppm/year

### 17.3.2 Phase

Phase represents the phase of waveform output to the reference phase synchronization output waveform. This does not include noise and DC.

Setting range of the phase (main-output)	-1800.000° to +1800.000°(resolution 0.001°) Common to the oscillation start/end phase of the gated single sweep and burst
Setting range of the phase (sub-output/sub-waveform)	-180.000° to +180.000°(resolution 0.001°)
Reference phase synchronization output waveform	A square wave with duty 50% rising at zero degree of reference phase of the waveform output. This can be output from the synchronization/sub-output. When the waveform is noise or DC, fixed to low level.

## 17.4 Output Characteristics

It specified only to the main output except section 17.4.5.

### 17.4.1 Amplitude

Setting range	0Vp-p to 20Vp-p/open 0Vp-p to 10Vp-p/50Ω A peak value combining waveform amplitude and DC offset is limited to ±10V/open or less. With frequency exceeding 110MHz, the value combining waveform amplitude and DC offset is limited to ±2V/open.
Setting resolution	999.9mVp-p or less 4 digits or 0.1mVp-p 1Vp-p or more 5 digits or 1mVp-p
Accuracy <sup>*1</sup>	±(1% of Amplitude setting [Vp-p] + 2mVp-p)/open Conditions: Continuous oscillation, 1kHz sine wave, load open, amplitude setting 20mVp-p or more, DC offset setting 0V, auto range, external addition off, and effective value measurement
Approval unit	Vp-p, Vpk, Vrms, dBV, dBm Setting with high level/low level, including DC offset, is also possible. Vp-p is applied to the standard waveforms and arbitrary waveform with amplitude range of ±FS. Vpk is applied to the standard waveforms and arbitrary waveforms with amplitude range of -FS/0 or 0/+FS.

	<p>Vrms, dBV, and dBm are applied to sine wave and noise only.</p> <p>0dBV shall be 1Vrms.</p> <p>Regarding dBm, voltage that is 1mW at the specified load impedance (excluding High-Z) shall be 0dBm.</p>
Range	<p>Auto, hold (switch)</p> <p>Maximum output voltage range: 20Vp-p, 4Vp-p, 0.8Vp-p</p> <p>Amplitude attenuator range: 0dB, -10dB, -20dB, -30dB</p>
Resolution of waveform amplitude	<p>Approx. 16 bit</p> <p>Conditions: Amplitude setting 8mVp-p/open or more, DC offset setting 0V, auto range, external addition off, and standard waveform with amplitude range of <math>\pm</math>FS.</p> <p>Remarks: In order to narrow down the digitally amplitude, such as when the amplitude conditions below, AM or amplitude sweep, amplitude resolution is reduced.</p>

### 17.4.2 DC Offset

Setting range	<p><math>\pm</math>10V/open, <math>\pm</math>5V/50<math>\Omega</math></p> <p>A peak value combining waveform amplitude and DC offset is limited to <math>\pm</math>10V/open or less.</p> <p>With frequency exceeding 110MHz, the value combining waveform amplitude and DC offset is limited to <math>\pm</math>2V/open.</p>
Setting resolution	<p><math>\pm</math>499.9mV or less      4 digits or 0.1mV</p> <p><math>\pm</math> 0.5V or more          5 digits or 1mV</p>
Accuracy* <sup>1</sup>	<p><math>\pm</math>(   1% of DC offset setting [V]   +10mV + 0.5% of amplitude setting [Vp-p])/open</p> <p>Conditions: Continuous oscillation, 10MHz or less, sine wave, load open, auto range, external addition off, and 20°C to 30°C</p> <p>Beyond the temperature range of 20°C to 30°C, add 1mV/°C typ.</p>
Range	<p>Auto, hold (switch)</p> <p>Maximum output voltage range: 20Vp-p, 4Vp-p, 0.8Vp-p</p> <p>When waveform is DC, it applies to DC offset only.</p> <p>Otherwise, common in the amplitude range.</p>

### 17.4.3 Load Impedance Setting

Function	Set and display the amplitude and the DC offset at the
----------	--

Setting range	output terminal voltage under the specified load condition. 1Ω to 10kΩ (resolution 1Ω), 50Ω, High-Z (load open)
---------------	--

#### 17.4.4 Waveform Output

Output on/off control	On, off (switch) (output terminal is in a released condition when off)
Output impedance	50Ω, unbalanced
Short-circuit protection	Protect against the short circuit to the signal GND
Output connector	Front panel, BNC receptacle (FCTN OUT)
Signal GND	Insulated from enclosure, maximum 42Vpk (DC + ACpeak) Each channel independent. Between channels is also maximum 42Vpk.

#### 17.4.5 Synchronization/Sub-Output

Output signals	Reference phase synchronization, internal modulation synchronization, burst synchronization, sweep synchronization, internal modulation signal, sub-waveform, sweep X drive and off switching (Forcibly turned off when the oscillation frequency exceeds 160MHz).
Sub-waveform	Analog waveform output synchronized with the main-output. Phase is variable to the reference phase synchronization signal, and the amplitude and offset are also adjustable
Available waveform	Sine, square(duty 50%), triangle(symmetry 50%), rising ramp, falling ramp, noise, arbitrary
Internal modulation waveform	Modulation waveform at the time of internal modulation oscillation. Phase is variable to the reference phase synchronization signal, and which amplitude and offset are also adjustable independent from the modulation depth.
Output voltage (at each type of synchronized signal)	TTL level (low level 0.4V/open or less, high level 2.7V/open or more)
Output voltage (sub-waveform/internal modulation waveform/sweep X drive)	
Amplitude setting range	0Vp-p~6Vp-p/open setting resolution 1mVp-p
DC offset setting range	±3V/open, setting resolution 1mVp-p A peak value combining waveform amplitude and DC offset is limited to ±3V/open or less.
Output impedance	50Ω, unbalanced

Load impedance	50Ω or higher recommended
Output connector	Front panel, BNC receptacle (SYNC/SUB OUT)
Signal GND	Insulated from enclosure, same potential as the waveform output.

## 17.5 Signal Characteristics

It specified only to the main-output.

### 17.5.1 Sine Wave

Amplitude frequency characteristics\*<sup>1</sup>

Up to 100kHz	±0.1dB
100kHz to 5MHz	±0.15dB
5MHz to 20MHz	±0.2dB
20MHz to 50MHz	±0.5dB
50MHz to 100MHz	±0.7dB
100MHz to 200MHz	±0.8dB

Conditions: Continuous oscillation, 50Ω load, amplitude setting 50mVp-p to 10Vp-p/50Ω, for more than 100MHz, 50mVp-p to 2Vp-p/50Ω, DC offset setting 0V, auto range, external addition off, effective value measurement, and reference frequency 1kHz.

Total harmonic distortion \*<sup>1</sup>

20Hz to 20kHz	0.04% or less
---------------	---------------

Conditions: Continuous oscillation, 50Ω load, amplitude setting 1Vp-p/50Ω, DC offset setting 0V, auto range, external addition off, and sum up to 7th harmonic, noise is not included.

Harmonic spurious\*<sup>1</sup>

Up to 1MHz	-60dBc or less
1MHz to 5MHz	-50dBc or less
5MHz to 30MHz	-40dBc or less
30MHz to 200MHz	-30dBc or less

Conditions: Continuous oscillation, 50Ω load, amplitude setting 1Vp-p/50Ω, DC offset setting 0V, auto range, external addition off, and sum up to 5th harmonic.

Non-harmonic spurious\*<sup>1</sup>

Up to 8MHz	-55dBc or less
------------	----------------

8MHz to 80MHz	-55dBc+20 dB/dec or less
80MHz to 200MHz	-35dBc or less
	Conditions: Continuous oscillation, 50Ω load, amplitude setting 2Vp-p/50Ω, DC offset setting 0V, measured at 500MHz bandwidth.

## 17.5.2 Square Wave

### Duty

Variable Range (switch)

Standard, Extended (switch)

Standard range: Duty can be changed within the range where jitter is low and a pulse does not disappear. The setting range of the duty narrows as the frequency rises.

Duty is fixed to 50% at 70MHz.

Duty is variable at the range of 10 to 90% at 14MHz.

Extended range: There is jitter of 700ps rms or less typ., and the duty can be always changed at the maximum range. When the pulse width is narrower than 2.4ns, pluses may disappear. However, when the frequency is not 1/(integer) of 420MHz, it becomes equal to the specified duty on average. (When it is 1/(integer), up to approx. 2.4ns of inaccuracy may occur at the edge time).

Setting range

Standard range 0.0100% to 99.9900% (resolution 0.0001%)

Extended range 0.0000% to 100.0000% (resolution 0.0001%)

Upper and lower limit of standard range setting

Upper limit (%)  $100 - \text{Frequency [Hz]} / 1,400,000$

Lower limit (%)  $\text{Frequency [Hz]} / 1,400,000$

Duty accuracy\*1

Up to 300kHz

±0.1% of period (duty setting is 1% to 99%)

300kHz to 3MHz

±1% of period (duty setting is 5% to 95%)

3MHz to 10MHz

±3% of period (duty setting is 40% to 60%)

Conditions: Continuous oscillation, 50Ω load, amplitude setting 10Vp-p/50Ω, DC offset setting 0V

Rising time, falling time

4.6ns or less\*1, 4.4ns or less typ.

However, for burst oscillation and gated single sweep with a stop level setting, it is approx. 5.7ns

	Conditions: 50Ω load, amplitude setting 2Vp-p/50Ω, DC offset setting 0V
Overshoot	5% or less typ.
Jitter	Duty variable range standard 85ps rms or less typ. (100Hz or more) Duty variable range extended 700ps rms or less typ. Conditions: Continuous oscillation, 50Ω load, amplitude setting 10Vp-p/50Ω, DC offset setting 0V

### 17.5.3 Pulse Wave

Pulse width	
Duty setting range	0.0001% to 99.9999% (resolution 0.0001%)
Time setting range	6.88ns to 99.9999Ms (resolution 0.001% or less of period or 0.01ns) Setting range of pulse width duty and pulse width time are limited by frequency, leading time and trailing time.
Upper and lower limit of time setting	Upper limit [s] $\text{period} - (\text{leading time} + \text{trailing time}) * 0.85$ Lower limit [s] $(\text{leading time} + \text{trailing time}) * 0.85$ Upper and lower limits of duty setting are computed by the upper and lower values/period above.
Leading time, trailing time	
Setting range	4.21ns to 58.8Ms (resolution 3 digits or 0.01ns or 1ppm of period) Independent setting of leading/trailing times. Leading and trailing times are limited by frequency, pulse width duty, and pulse width time.
Minimum setting value	1ppm of period or 4.21ns, whichever is larger
Overshoot	5% or less typ.
Jitter	90ps rms or less typ. (100Hz or more) Conditions: Continuous oscillation, 50Ω load, amplitude setting 10Vp-p/50Ω, DC offset setting 0V

### 17.5.4 Ramp Wave

Setting range of symmetry	0.00% to 100.00% (resolution 0.01%)
---------------------------	-------------------------------------

### 17.5.5 Noise

Noise equivalent bandwidth setting range	Select from 100M/30M/10M/3M/1M/300k/100kHz
--	--

### 17.5.6 Parameter-Variable Waveform

For each of the following waveforms, a waveform with multiple parameters which are arbitrary varied can be generated.

**a) Steady sine group**

Unbalance sine  
Clipped sine  
CF controlled sine  
Conduction angle controlled sine  
Staircase sine  
Multiple-cycle sine

**b) Transient sine group**

On-phase controlled sine  
Off-phase controlled sine  
Chattering-on sine  
Chattering-off sine

**c) Pulse group**

Gaussian pulse  
Lorentz pulse  
Haversine  
Half-sine wave pulse  
Trapezoid pulse  
 $\text{Sin}(x)/x$

**d) Transient response group**

Exponential rise  
Exponential fall  
Second order LPF step response  
Damped oscillation

**e) Surge group**

Oscillation surge  
Pulse surge

**f) Other group**

Trapezoid wave with offset  
Half-sine edge pulse  
Bottom referenced ramp



## 17.6 Modulated Oscillation Mode

### 17.6.1 General

Operation in other oscillation mode	Partly possible in the burst and sweep oscillation mode.
Modulation type	FM, FSK, PM, PSK, AM, DC offset modulation and PWM When the sweep function is used simultaneously the modulation type which overlaps with that of the sweep type cannot be selected.
Modulation operation	Start and stop
Modulation source	
Other than FSK, PSK	Internal, external (switch) In addition, CH2 can select the same modulation source as CH1 (internal only). When the sweep function is used simultaneously, the internal modulation source cannot be selected.
FSK, PSK	Internal, external (switch) In addition, CH2 can select the same modulation source as CH1. External modulation of FSK and PSK uses an external trigger input terminal. When the burst function is used simultaneously, FSK and PSK cannot be selected in the mode other than auto burst.
Internal modulation waveform	
Other than FSK, PSK	Sine wave, square wave (duty 50%), triangle wave (symmetry 50%), rising ramp wave, falling ramp wave, noise, arbitrary wave
FSK, PSK	Square wave (duty 50%)
Noise equivalent bandwidth	Select from 100M/30M/10M/3M/1M/300k/100kHz
Internal modulation frequency	
Other than FSK, PSK	0.1mHz to 20MHz (resolution 12 digits or 1 $\mu$ Hz)
FSK, PSK	0.1mHz to 5MHz (resolution 11 digits or 1 $\mu$ Hz)
Internal modulation synchronization output	
Output waveform	A square wave with duty 50% rising at the zero phase of the internal modulation waveform When internal modulation waveform is noise, the level is fixed to low.
Output connector	Shared with synchronization/sub-output connector (SYNC/SUB OUT).
Internal modulation waveform output	
Output voltage	-3V to +3V/open

Output connector	Shared with synchronization/sub-output connector (SYNC/SUB OUT).
External modulation input (except for FSK and PSK)	
Input voltage range	$\pm 1V$ full scale
Maximum allowable input	$\pm 2V$
Input impedance	10k $\Omega$ , unbalanced
Input frequency	DC to 400 kHz (-3 dB)
Input connector	Front panel (WF1967)/rear panel (WF1968), BNC receptacle (MOD/ADD IN) Shared with external addition input. Simultaneous use with the addition operation is not possible.
Isolation	Insulated from enclosure, same potential as the waveform output.
External modulation input (FSK and PSK)	
Polarity	Positive, negative (switch) In the FSK modulation, when the polarity is set as positive, the carrier frequency is output for low-level input, and the hop frequency is output for high-level input. When the polarity is set as negative, the other way around. In the PSK modulation, when the polarity is set as positive, the steady phase is output for low-level input, and the phase shift is output for high-level input. When the polarity is set as negative, the other way around.
Input frequency	DC to 5MHz
Input connector	External trigger input (TRIG IN) Input voltage and input impedance depend on external trigger input specification
Signals selectable for synchronization/sub-output	
	Reference phase synchronization
	Internal modulation synchronization (when modulation source is internal)
	Internal modulation signal (when modulation source is internal and other than FSK and PSK)
	Off (Forcibly turned off also when the oscillation frequency may exceed 160MHz)

### 17.6.2 FM

Carrier waveform	Standard waveforms except for noise, pulse wave and DC, and arbitrary waveforms
Peak deviation setting range	0.00 $\mu$ Hz to less than 100MHz (resolution 8 digits or 0.01 $\mu$ Hz)

Carrier frequency  $\pm$  peak deviation is limited within the allowable range of frequency for each carrier waveform. Sub-output is turned off when the peak frequency exceeds 160MHz.

With the peak frequency exceeding 110MHz, the value combining waveform amplitude and DC offset is limited to  $\pm 2V$ /open.

### 17.6.3 FSK

Carrier waveform	Standard waveforms except for noise, pulse wave and DC, and arbitrary waveforms.
Hop frequency setting range	Within the allowable range of frequency for each carrier waveform (resolution 8 digits or 0.01 $\mu$ Hz). Sub-output is turned off when the carrier or hop frequency exceeds 160MHz.

### 17.6.4 PM

Carrier waveform	Standard waveforms except for noise and DC, and arbitrary waveforms
Peak deviation setting range	0.000 $^\circ$ to 180.000 $^\circ$ (resolution 0.001 $^\circ$ ) Carrier phase $\pm$ peak deviation is limited within the range of $\pm 1800^\circ$ .
Remarks	Carrier frequency is limited to 160MHz or less.

### 17.6.5 PSK

Carrier waveform	Standard waveforms except for noise and DC, and arbitrary waveforms
Deviation setting range	-1800.000 $^\circ$ to +1800.000 $^\circ$ (resolution 0.001 $^\circ$ ) Carrier phase + deviation is limited within the range of $\pm 1800^\circ$ .
Remarks	Amplitude frequency characteristic of sine wave during PSK is limited to 87MHz -3dB.

### 17.6.6 AM

#### a) Not DSB-SC

Carrier waveform	Standard waveforms except for DC, and arbitrary waveforms
Modulation depth setting range	0.0 % to 100.0 % (resolution 0.1%)
Remarks	When the modulation depth is 0%, amplitude becomes equal to 1/2 of setting.

**b) DSB-SC(Double Side Band - Suppressed Carrier)**

Carrier waveform	Standard waveforms except for DC, and arbitrary waveforms
Modulation depth setting range	0.0% to 100.0% (resolution 0.1%)
Remarks	When the modulation depth is 100%, maximum amplitude becomes equal to setting. The component of the carrier frequency is zero during DSB-SC.
Remarks common to a) and b)	Sub-output is turned off when the carrier frequency exceeds 160MHz. The output voltage setting is limited to [4Vp-p/open] or less when the carrier frequency exceeds 110MHz.

**17.6.7 DC Offset Modulation**

Carrier waveform	Standard waveforms and arbitrary waveforms
Peak deviation setting range	0V~10V/open
Peak deviation setting resolution	499.9mV or less      4 digits or 0.1mV 0.5V or more          5 digits or 1mV

**17.6.8 PWM**

Carrier waveform	Square wave and pulse wave
Peak deviation setting range	
Square Wave	
Duty variable range standard	0.0000% to 49.9900% (resolution 0.0001%)
Duty variable range extend	0.0000% to 50.0000% (resolution 0.0001%)
Pulse Wave	0.0000% to 49.9000%(resolution 0.0001%)
	Carrier duty $\pm$ peak deviation is limited within the allowable range of duty for each carrier waveform.

**17.7 Sweep Oscillation Mode****17.7.1 General**

Use of modulation function	External modulation other than sweep type is simultaneously available. (FSK/PSK are not available)
Sweep types	Frequency, phase, amplitude, DC offset, and duty
Sweep function	One way (ramp waveform), shuttle (triangular waveform) (switch) Linear, logarithmic (switch)

	Common regardless of sweep type.
	However, logarithmic can use only frequency sweep.
Sweep range setting	Specify starting value and stop value, or center value and span value However, the center value is also a simple average of starting value and stop value during frequency logarithmic sweep. Assigning a marker value to a center value is possible (the other way around is also possible).
Setting range of Sweep Time	0.1ms to 10,000s (resolution 4 digits or 0.1ms)
Sweep mode	Common regardless of sweep type. Continuous, single, gated single (switch) Common regardless of sweep type. For gated single, it oscillates only during running sweep. However, when the waveform is DC, gated single is not available.
Operation	Start, stop, hold, resume, starting value output and stop value output.
Trigger source (used for single sweep and gated single sweep)	Internal, external input terminal (switch) In addition, CH2 can select the same trigger source as CH1. Common regardless of sweep type. Trigger delay setting is disabled. Manual trigger available.
Internal trigger oscillator for sweep (used for single sweep and gated single sweep)	
Period setting range	100.0 $\mu$ s to 10,000s (resolution 5 digits or 0.1 $\mu$ s)
Stop level setting (used for gated single sweep)	
Function	Specifies the signal level when gated single-sweep is stopped.
Setting range	-100.00% to +100.00% (amplitude full-scale reference and resolution 0.01%) or off When stop level is set to off, stops by set oscillation start/stop phase.
Remarks	Common regardless of sweep type When the waveform is noise, oscillation start/stop phase is invalid, stop level is always valid. When the waveform is DC, oscillation start/stop phase is invalid, stop level is invalid For phase sweep, sweep starting value is oscillation start phase and sweep stop value is oscillation stop phase
Oscillation stop unit when gated single	Cycle, Half Cycle (switch)

Sweep synchronization/marker output

Marker off at one-way	Low level is used from sweep starting value to half of sweep time. High level, otherwise
Marker off at shuffle	Low level is used from sweep starting value to sweep stop value. High level, otherwise
Marker on	Low level is used from sweep starting value to marker value. High level, otherwise.
Output connector	Shared with synchronization/sub-output connector (SYNC/SUB OUT)

Sweep X drive output

Output voltage	-3V to +3V/open During sweep value rising, -3V to +3V, during falling, +3V to -3V
Output connector	Shared with synchronization/sub-output connector (SYNC/SUB OUT).

Sweep external control input

Input connector	Multi-I/O connector (MULTI IO) is used Enable, disable (switch) In WF1968, it allows shares by both channels, and settings on each channel.
Start	Starts sweep from beginning by falling input
Stop	Stops sweep by falling input
Hold/resume	Pauses sweep by falling input during running sweep Resumes sweep by falling input during pause
Remarks	For single sweep or gated single sweep, sweep starts once trigger received independently of the start by the multi-I/O connector

Sweep external trigger input (used for single sweep and gated single sweep)

Polarity	Positive, negative, disable (switch)
Input connector	External trigger input (TRIG IN) Input signal and input impedance depend on external trigger input specification.

Signals selectable for synchronization/Sub-output

- Reference phase synchronization
- Sweep synchronization/marker
- Sweep X drive
- Off (Forcibly turned off also when the oscillation frequency exceed 160MHz)

### 17.7.2 Frequency Sweep

Waveform	Standard waveforms except for noise, pulse wave and DC, and arbitrary waveforms
Setting range of start and stop frequency	0.01 $\mu$ Hz to 200MHz Resolution: 0.01 $\mu$ Hz (< 50MHz), 0.1 $\mu$ Hz (50MHz $\leq$ ) Limited within the allowed setting range of frequency for each waveform. Sub-output is turned off when the peak frequency exceeds 160MHz. With the peak frequency exceeding 110MHz, the value combined waveform amplitude and DC offset is limited to $\pm 2$ V/open.

### 17.7.3 Phase Sweep

Waveform	Standard waveforms except for noise and DC, and arbitrary waveforms
Setting range of start and stop phase	-1800.000 $^{\circ}$ to 1800.000 $^{\circ}$ (resolution 0.001 $^{\circ}$ )

### 17.7.4 Amplitude Sweep

Waveform	Standard waveforms except for DC, and arbitrary waveforms
Setting range of start and stop amplitude	Oscillation frequency 110MHz or less 0Vp-p to 20Vp-p/open Oscillation frequency more than 110MHz 0Vp-p to 4Vp-p/open
Setting resolution of start and stop amplitude	999.9mVp-p or less    4 digits or 0.1mVp-p 1Vp-p or more        5 digits or 1mVp-p

### 17.7.5 DC Offset Sweep

Waveform	Standard waveforms and arbitrary waveforms
Setting range of start and stop DC offset	Oscillation frequency 110MHz or less -10V to +10V/open Oscillation frequency more than 110MHz -2V to +2V/open
Setting resolution of start and stop DC offset	$\pm 499.9$ mV or less    4 digits or 0.1mV

Remarks	±0.5V or more      5 digits or 1mV When the waveform is DC, gated single sweep is not available
---------	--

### 17.7.6 Duty Sweep

Waveform	Square wave and pulse wave
Setting range of start and stop duty	
Square wave	
Duty variable range standard	0.0100% to 99.9900% (resolution 0.0001%)
Duty variable range extend	0.0000% to 100.0000% (resolution 0.0001%)
Pulse wave	0.0170% to 99.9830% (resolution 0.0001%)
	Limited within the allowed setting range of duty according to the oscillation frequency.

## 17.8 Burst Oscillation Mode

Use of modulation function	In auto burst mode, modulations are possible simultaneously. In other burst modes, modulations except for FSK and PSK are possible simultaneously.
Burst mode	
Auto burst	Repeats oscillating the number of mark wave and stopping the number of space wave. Trigger is disabled
Trigger burst	Oscillates the number of mark wave in synchronization with trigger
Gate	Oscillates integer multiples in cycles or half-cycles, in synchronization with the gate signal However, when the waveform is noise, it makes oscillation on/off by the gate signal.
Triggered gate	Gate oscillation, that gate is toggled on and off for each trigger.
Target waveform	
Auto, trigger burst	Standard waveforms except for noise and DC, and arbitrary waveforms
Gate, triggered burst	Standard waveforms except for DC, and arbitrary waveforms
Mark wave number setting range	0.5 to 999,999.5 cycles, 0.5 cycle unit
Space wave number setting range	0.5 to 999,999.5 cycles, 0.5 cycle unit
Oscillation stop unit at gate	Cycle, Half Cycle (switch)
Setting range of start/stop oscillation phase	-1800.000° to +1800.000° (resolution 0.001°)



	Remarks: The same setting value as the phase setting in Section 17.3.2
Stop level setting range	
Function	Specifies the signal level when oscillation is stopped.
Setting range	-100.00% to +100.00% (amplitude full-scale reference and resolution 0.01%) or off
	When stop level is set to off, stops by set oscillation start/stop phases.
Remarks	When the waveform is noise, oscillation start/stop phases are invalid and stop level is always valid .
Trigger source (used for other than auto burst)	Internal trigger oscillator, external input terminal (switch) In addition, CH2 can select the same trigger source as CH1. Manual trigger available.
Internal trigger oscillator for burst (used except for auto burst)	
Period setting range	1.0 $\mu$ s to 1,000s (resolution 5 digits or 0.1 $\mu$ s)
Burst external trigger input (used except for auto burst)	
Polarity	Positive, negative, disabled (switch)
Input connector	External trigger input terminal (TRIG IN) Input signal and input impedance depend on external trigger input specification.
Trigger delay setting range	0.0ns to 1000.0000s (resolution 8 digits or 0.1ns) Additional delay approx. 380ns Enabled only for trigger burst (disabled for gate and triggered gate) and enabled for internal/external trigger sources.
Trigger jitter	0.2ns rms or less typ.
Burst synchronization output	
Polarity	Low level during oscillation, otherwise high level
Output connector	Shared with synchronization/sub-out connector (SYNC/SUB OUT)
Signals selectable for synchronization/sub-output	Reference phase synchronization Burst synchronization OFF In the modulated oscillation mode, output specific to the modulation mode is also selectable.

## 17.9 Synclator Function

Function	Function that makes the same frequency for the signal
----------	---

	input from the synchronization source and the signal output to the main output. The frequency of the input signal is displayed on the screen.
Frequency range	20Hz to 10MHz
Synchronization target	Only external trigger input terminal is available. In addition, CH2 can select the same trigger source as CH1. Trigger delay setting is invalid.
Synchronization source input	
Polarity	Positive, Negative (switch)
Input connector	External trigger input terminal (TRIG IN) Input signal and input impedance depend on external trigger input specification.
Phase difference	The phase between the signal input from the synchronization source and the signal output to the main-output can be set freely in the phase setting (however, it will not become the same phase with 0 setting).
Limitations	<ul style="list-style-type: none"> <li>• Not available for the FM, PSK, FSK, frequency sweep and burst except auto, and when the waveform is noise, DC and pulse.</li> <li>• Not available together with the sequence function (→17.11)</li> <li>• Not available when in 2-channel coordination operation (→17.13) However, by making the same synchronization source of CH2 to CH1, equivalent operation to the 2-phase output, differential output, differential output 2 can be achieved.</li> </ul>

## 17.10 Trigger

External trigger input	Independent for each channel, however CH1 input can be shared with CH2
Usage	For single sweep, gated single sweep, trigger burst, gate, trigger gate and synclator functions
Input voltage	TTL level (low level 0.8V or lower, high level is 2.6V or higher)
Maximum allowable input	-0.5V to +5.5V
Polarity	Switches positive, negative or off (off is not available for synclator) Each setting is independent for FSK/PSK, sweep and synclator.
Minimum pulse width	5ns

Input impedance	10k $\Omega$ (pull up to +3.3V), unbalanced
Input connector	Front panel (WF1967)/rear panel (WF1968), BNC receptacle (TRIG IN)
Manual trigger	Panel key operation
Usage	For single sweep, gated single sweep, trigger burst, gate and trigger gate (Not available for synclator)
Internal trigger oscillator	Independent for sweep and burst, and Independent for each channel See the internal trigger oscillation in each section (Not available for synclator).

## 17.11 Sequences

Memory for saving sequence	10 sequences (saved in the built-in non volatile memory) Allowed saving to the USB flash memory
Maximum number of steps	255 steps at a maximum per sequence (the steps before start are excluded)
Interoperability between channels	Sequence mode is applied both 2 channels in the sequence mode Step control is shared
Step control parameters	Step time, hold operation, jump destination, jump count, step end phase, branch operation, step termination control, step synchronization code output
Channel parameter in steps	Waveform, frequency, phase, amplitude, DC offset and square wave duty
Intra-step operation	Constant, keep, linear interpolation (excluding waveform switching)
Step time setting range	0.1 ms to 1,000s (resolution 4 digits or 0.01ms)
Jump count setting range	1 to 9999 or infinite
Step end phase setting range	0.000° to 360.000°(CH1 reference phase resolution 0.001°) or disabled
Branch operation	
State branch	Check the state branch input via the multi-I/O connector at step end. Branches to the specified step when the branch is detected.
Event branch	Immediately branches to the specified step by event branch operation or input.
Control at step end	Stop or move to the next step
Step synchronization code output	4 bit code specified for each step is output to the multi-I/O connector Also LSB can output to the synchronization/sub output

	connector (SYNCOUT/SUB OUT).
Available waveforms	Sine wave, square wave, noise, and arbitrary waveform Ramp wave and variable parameter waveforms are available by saving them as arbitrary waveforms
Maximum number of waveforms	128
Phase at step start	The next step of DC or noise starts oscillation from each channel reference phase 0°
Sequence operation	Start, stop, hold, resume and event branch
Sequence external control	
Input connector	Use the multi-I/O connector (MULTI I/O)
Control items	Start or state branch, stop, hold/resume, event branch
Sequence external trigger input (start trigger)	
Polarity	Switches positive, negative or off
Input connector	External trigger input (TRIG IN) for CH1 Input voltage and input impedance depend on external trigger input specification.
Limitations	Used with synclator function is not available

## 17.12 Other I/Os

External 10 MHz frequency reference input	
Select frequency reference	Enabled and disabled (switch)
Input voltage	0.5Vp-p to 5Vp-p
Maximum allowable input	10Vp-p
Input impedance	10kΩ, unbalanced, AC coupled
Input frequency	10MHz (±5ppm : ±50Hz)
Input waveform	Sine or square wave (50±5% duty)
Input connector	Rear panel, BNC receptacle (10MHz REF IN)
Signal GND	Insulated from enclosure, maximum 42Vpk (DC + ACpeak)
Frequency reference output (WF1967 and WF1968, to synchronize multiple units)	
Output voltage	1Vp-p/50Ω square wave
Output impedance	50Ω, AC coupled
Output frequency	10MHz
Output connector	Rear panel, BNC receptacle (REF OUT)
External addition input	
Addition gain	Switches x0.4, x2, x10 or off The output voltage are fixed to 0.8Vp-p for x0.4, 4Vp-p for x2 and 20Vp-p for x10. During external modulation, it is dedicated to external modulation input.

Input voltage range	-1V to +1V
Maximum allowable input	±2V
Input frequency	DC to 100MHz (-3dB)
Input impedance	10kΩ, unbalanced
Input connector	Front panel (WF1967)/rear panel (WF1968), BNC receptacle (MOD/ADD IN) Shared with external modulation input. Used with the external modulation and addition operation is not available.
Signal GND	Insulated from enclosure, same potential as the waveform output

### 17.13 2-Channel Coordination (WF1968 only)

Channel mode

Channel mode	Operation:
Independent	Independent setting
2 phases	Oscillation in the same frequency and the same oscillation mode (the same modulation type for modulation oscillation and the same sweep type for sweep oscillation). Apply to the standard waveform except for noise and DC, and arbitrary waveform. Keep the same frequency also for frequency sweep, internal frequency modulation, and internal FSK. External frequency modulation and external FSK are not allowed. Phase is independent setting among each channel. Burst and gated single sweep are not allowed.
Constant frequency difference	Keep the difference of frequency constant. Oscillation in the same oscillation mode (the same modulation type for modulation oscillation and the same sweep type for sweep oscillation) Apply to the standard waveform except for noise and DC, and arbitrary waveform. Keep the same frequency difference also for frequency sweep, internal frequency modulation and internal FSK. External frequency modulation and external FSK are not allowed. Burst and gated single sweep are not allowed.

Constant frequency ratio	<p>Keep the ratio of frequency constant. Oscillation in the same oscillation mode (the same modulation type for modulation oscillation and the same sweep type for sweep oscillation).</p> <p>Apply to the standard waveform except for noise and DC, and arbitrary waveform.</p> <p>Keep the same frequency ratio also for frequency sweep, internal frequency modulation, and internal FSK.</p> <p>External frequency modulation and external FSK are not allowed.</p> <p>Burst and gated single sweep are not allowed.</p>
Differential output	<p>Same frequency, amplitude, and DC offset. Reverse phase waveform. Oscillates on the same oscillation mode (for modulation oscillation, modulation type is also same. For sweep oscillation, sweep type is also same).</p> <p>Apply to the standard waveform and arbitrary waveform.</p> <p>Keep the different output, even for each type of sweep and internal modulation.</p> <p>External modulation is not allowed.</p> <p>Burst and gated single sweep are not allowed.</p> <p>External addition is not allowed.</p>
Differential output2	<p>Same as differential output but DC is reversed polarity.</p> <p>When the hot sides of CH1 and CH2 are used as the output, including DC, it is possible to obtain the double amount of output voltage (however, the output impedance is 100Ω).</p>

## Equivalence setting and equivalence operation functions

	Yes
Frequency difference setting range	0.00μHz to less than 200MHz Resolution: 0.01μHz CH2 frequency - CH1 frequency
Frequency ratio N:M setting range	1 to 9,999,999 (for both N and M) N:M = CH2 frequency:CH1 frequency Frequency resolution is limited to $N \times 0.01\mu\text{Hz}$ for CH1, $M \times 0.01\mu\text{Hz}$ for CH2 (also for frequency sweep, internal FM and internal FSK)
Phase synchronization operation	Auto executed when the channel mode is changed
Time difference between channels for 2-phase	$\pm 10\text{ns}$ or less typ., $\pm 20\text{ns}$ or less <sup>*1</sup> Conditions: Continuous oscillation, same waveform (sine wave or square wave), load 50Ω, DC offset setting 0V, amplitude setting 10Vp-p/50Ω
Limitations	See (17.9) for parallel use with the synculator function

## 17.14 Synchronization of Multiple Units

### Connection

Connect the frequency reference output of the master unit to the frequency reference input of the slave unit  
 Connect the frequency reference output of the slave unit to the frequency reference input of the other slave unit

#### Connection method 1

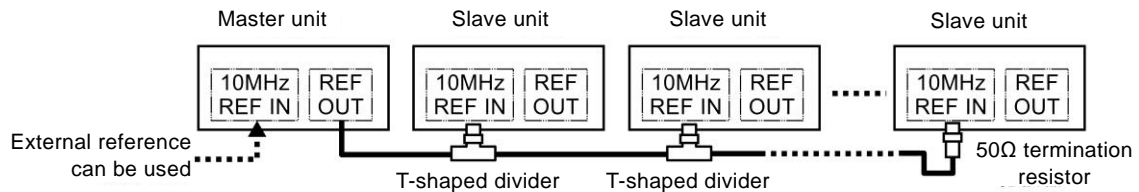

#### Connection method 2

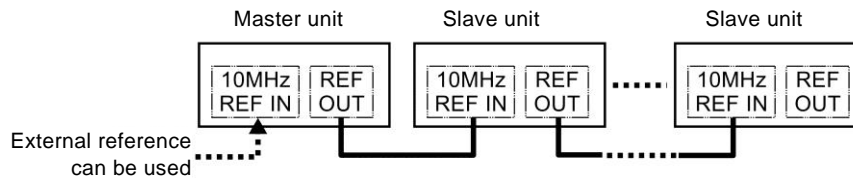

### Connection cables

#### Cable type

Characteristic impedance 50 Ω series coaxial cable with BNC connector (RG-58A/U etc.)

#### Restriction to cable length

1m or less between units, total cable length is 3m or less

### Maximum number of units for connection

Connection method 1: 6 units including master unit

Connection method 2: 4 units including master unit

### Phase synchronization operation

Manual operation

### Time difference between unit

Delay of each channel against each of a master instrument on the Nth slave unit ( $1 \leq N$ )

Connection Method1:  $(31ns + (N-1) \times 5ns) \pm 25ns$  or less typ.

Connection Method2:  $(31ns + (N-1) \times 31ns) \pm 25ns$  or less typ.

Conditions: Continuous oscillation, same frequency, same phase, same waveform (sine wave and square wave), load 50Ω, DC offset setting 0V, amplitude setting 10Vp-p/50Ω, and connecting cable length of frequency reference output between external frequency reference input 1m (RG-58A/U)

## 17.15 User-defined Unit

Function	Set and display settings in any unit based on a specified conversion expression
Setting items	Frequency (Hz), cycle (sec), amplitude (Vp-p, Vpk), DC offset (V), phase (deg) and duty (%)
Conversion expression	[(internal setting)+n]×m, [log <sub>10</sub> (internal setting)+n]×m Specify a conversion expression and values of n and m. Internal setting indicates the value of Setting item above.
Unit string	Maximum 4 characters

## 17.16 Other Functions

Memory for saving setting	10 sets (saved in the built-in non volatile memory) Allowed saving to the USB flash memory
Parameter setting at power-on operation	
Power-off with front panel operation	The operation state just before when the power was turned off is restored (If the mode was sequence when the power was turned off, the sequence mode and the sequence execution state can be automatically restored)
Power off with shutting down a line	The contents of setting memory number 1 are applied (If the automatic sequence was on when the power was turned on, the sequence memory No. 1 is automatically loaded to attempt compilation/execution.)
Output on/off at power-on operation	Switches Last State, On, or Off

Power off method	Power-On Output setting		
	Last State	On	Off
Panel operation	The latest power off state is restored	Output on	Output off
Shutting down a line	Output off	Output on	Output off

Sequence on/off at power-on operation Switches Last State, On, or Off

Power off method	Power-On Sequence Auto Run setting		
	Last State	On	Off
Panel operation	The latest power off state is restored	The latest power off state is restored in	Oscillator
Shutting down a line	Oscillator	Sequences memory#1 auto execution	Oscillator



Remote control	GPIB IEEE-488.1, SCPI-1999/IEEE-488.2 USB USBTMC, USB 1.1 Full-speed LAN(Optional)
----------------	--

## 17.17 Options

PA-001-1318 multi-I/O cable	Cable with connector on one end, for connection to multi-I/O connector on rear panel. 2 m length. Cut off at one end.
PA-001-2342 LAN I/F	10BASE-T/100BASE-TX,RJ-45 connector

## 17.18 General Characteristics

Display	4.3 inch TFT color LCD
I/O ground	Signal grounds for waveform output (FCTN OUT), synchronize/sub-output (SYNC/SUB OUT), external modulation/addition input (MOD/ADD IN) are insulated from the enclosure. These signal grounds are shared in the same channel. The signal ground for the external 10MHz frequency reference input (10MHz REF IN) is insulated from the enclosure. Each of the signal grounds of CH1, CH2 and 10MHz REF IN are independent. The maximum withstand voltage is 42Vpk(DC+ACpeak) between insulated signal grounds and enclosures. Other signal grounds are connected to enclosures.
Power supply	
Power voltage range:	100 VAC to 230VAC $\pm$ 10% (250V or lower)
Power frequency range	50Hz/60Hz $\pm$ 2Hz
Power consumption	WF1967: 65VA or lower WF1968: 85VA or lower
Overvoltage category	II

Ambient temperature/humidity range conditions (see next image)

Guaranteed operation range      0°C to +40°C, 5 to 85%RH  
 (Where absolute humidity is 1 to 25g/m<sup>3</sup>, non-condensing)  
 The temperature range is limited for some specifications  
 Altitude: 2000m or lower

Storage requirements:              -10 to +50°C, 5 to 95%RH (Where absolute humidity is 1 to 29g/m<sup>3</sup>, non-condensing)

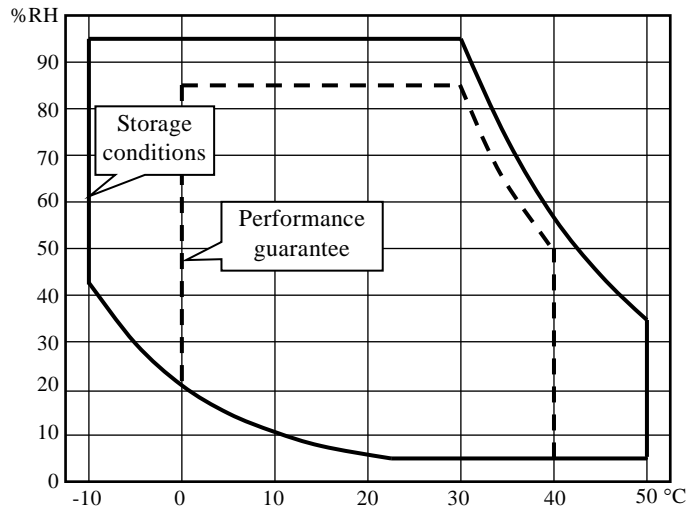

Warm-up time                              30 minutes or more typ.  
 Pollution degree                          2 (indoor use)  
 Outline dimension                        216 (W) x 132.5 (H) x 332 (D) mm (without protrusions)  
 Weight                                        Approx. 3.0kg (the main body without accessories)  
 Safety                                         EN 61010-1  
 EMC    EN 61326-1 (Group 1, Class A)  
     EN 61000-3-2  
     EN 61000-3-3  
 RoHS    Directive 2011/65/EU

■ Outline dimensional drawing (WF1967)

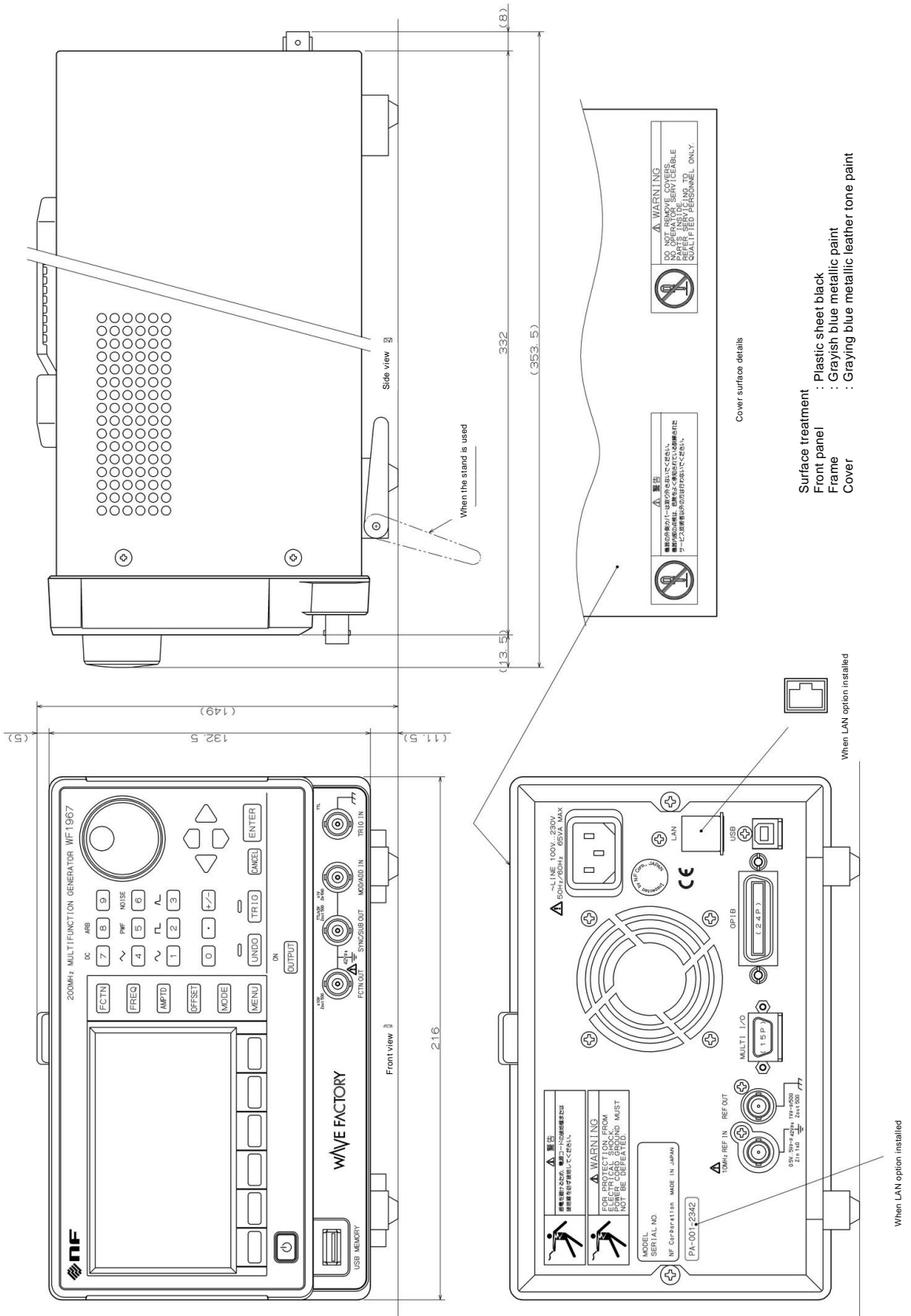



■ Rack mount dimensional drawing (EIA, for 1 unit)

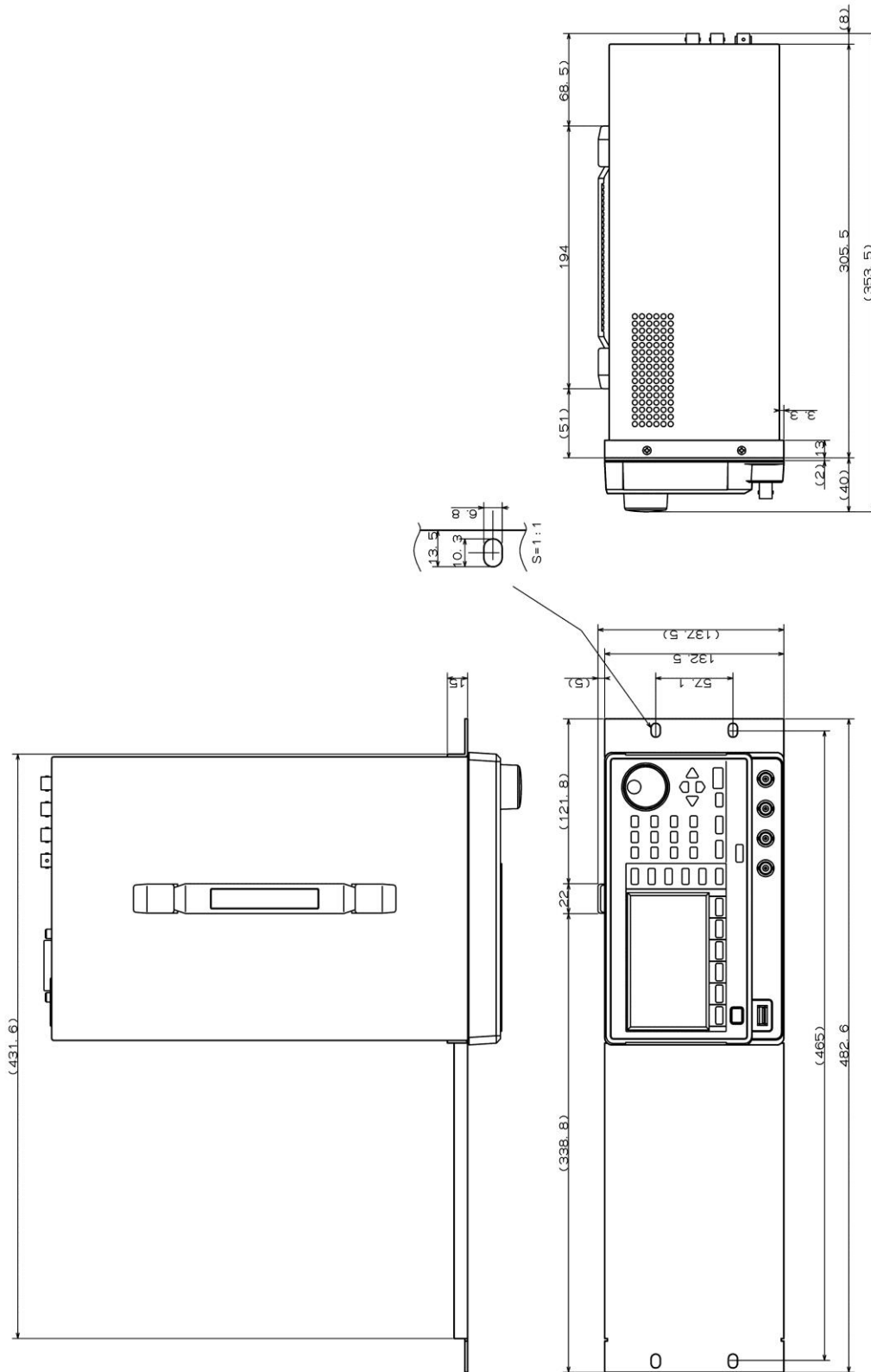

Surface treatment  
Rack mount adapters: Metallic gray paint

- Caution
- When mounting the unit in the rack, do not hold it only with the rack-mount adapters. Be sure to hold the main unit with brackets or shelves on the rack side.
  - Space of 5 mm or more is required above the upper surface.
  - When installing the unit to the rack, attach a blank panel, etc. on the panel side of the upper level of unit. If the space cannot be secured above the upper surface, the handle of the device needs to be removed. Please contact NF Corporation.

■ Rack mount dimensional drawing (EIA, for 2 units)

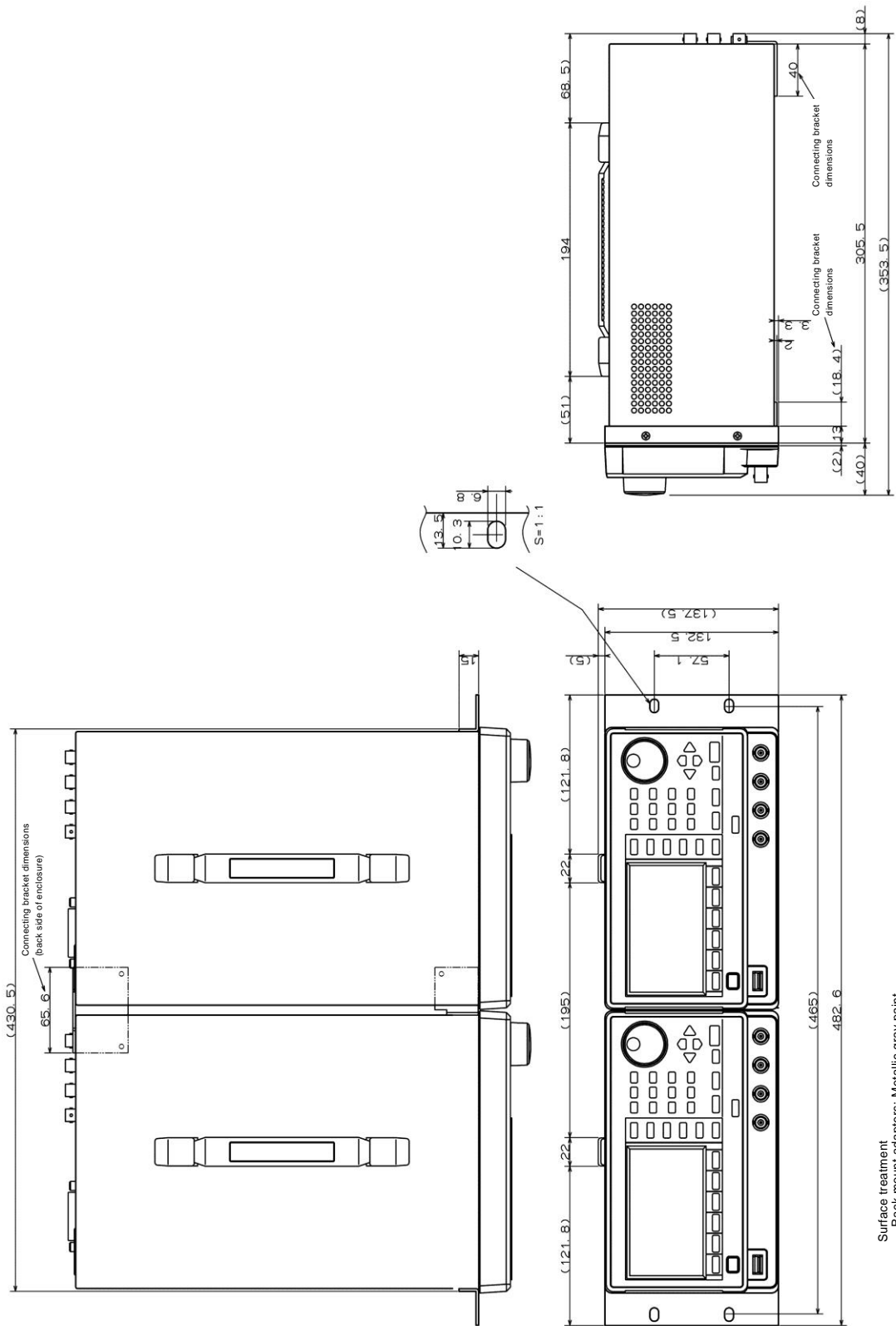

Surface treatment  
Rack mount adapters: Metallic gray paint

Caution

- When mounting the unit in the rack, do not hold it only with the rack-mount adapters.
  - Be sure to hold the main unit with brackets or shelves on the rack side.
  - Space of 5 mm or more is required above the upper surface.
  - When installing the unit to the rack, attach a blank panel, etc. on the panel side of the upper level of unit. If the space cannot be secured above the upper surface, the handle of the device needs to be removed.
- Please contact NF Corporation.

■ Rack mount dimensional drawing (JIS, for 1 unit)

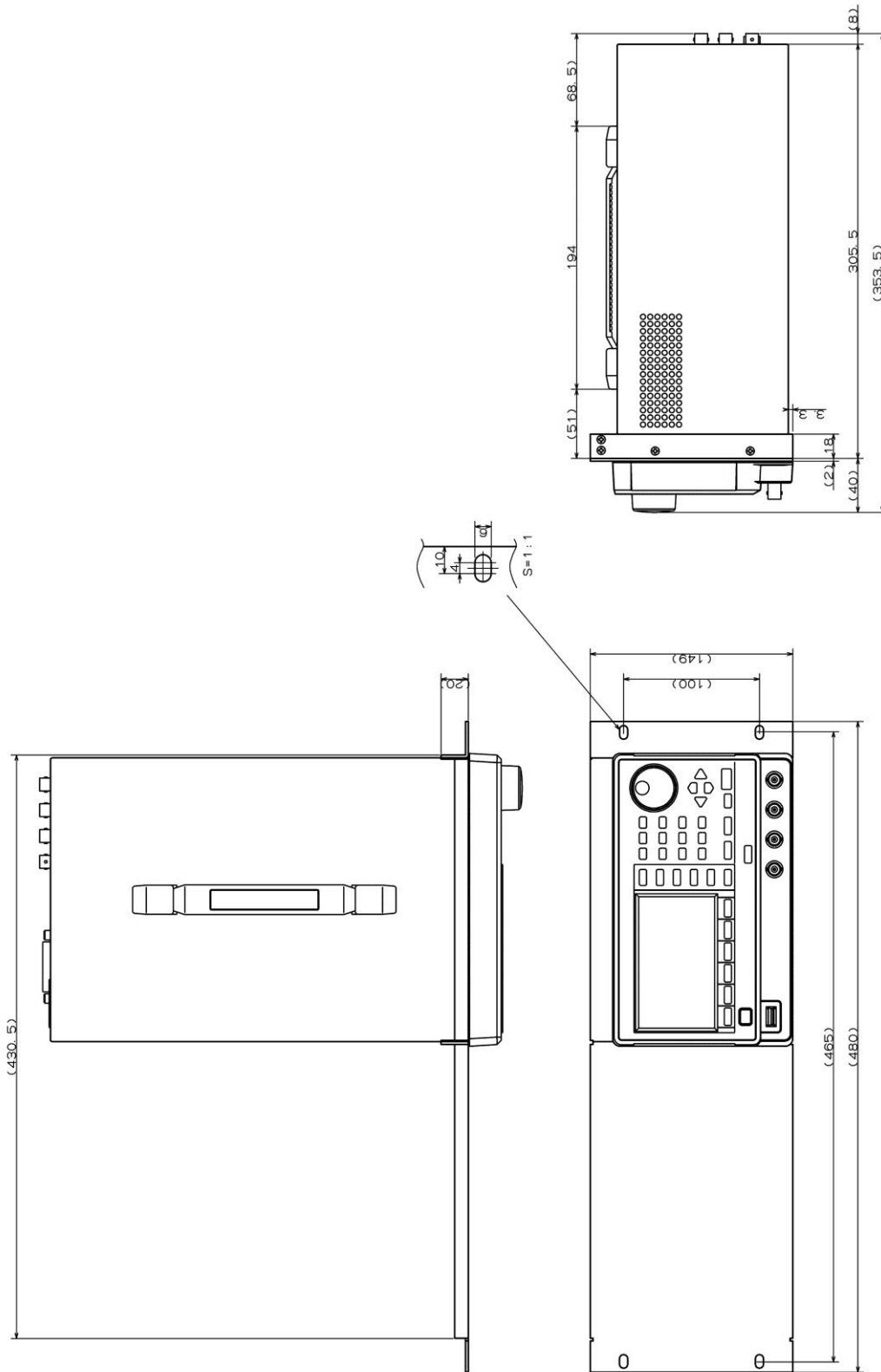

Surface treatment  
Rack mount adapters: Metallic gray paint

Caution

- When mounting the unit in the rack, do not hold it only with the rack-mount adapters.
- Be sure to hold the main unit with brackets or shelves on the rack side.

■ Rack mount dimensional drawing (JIS, for 2 units)

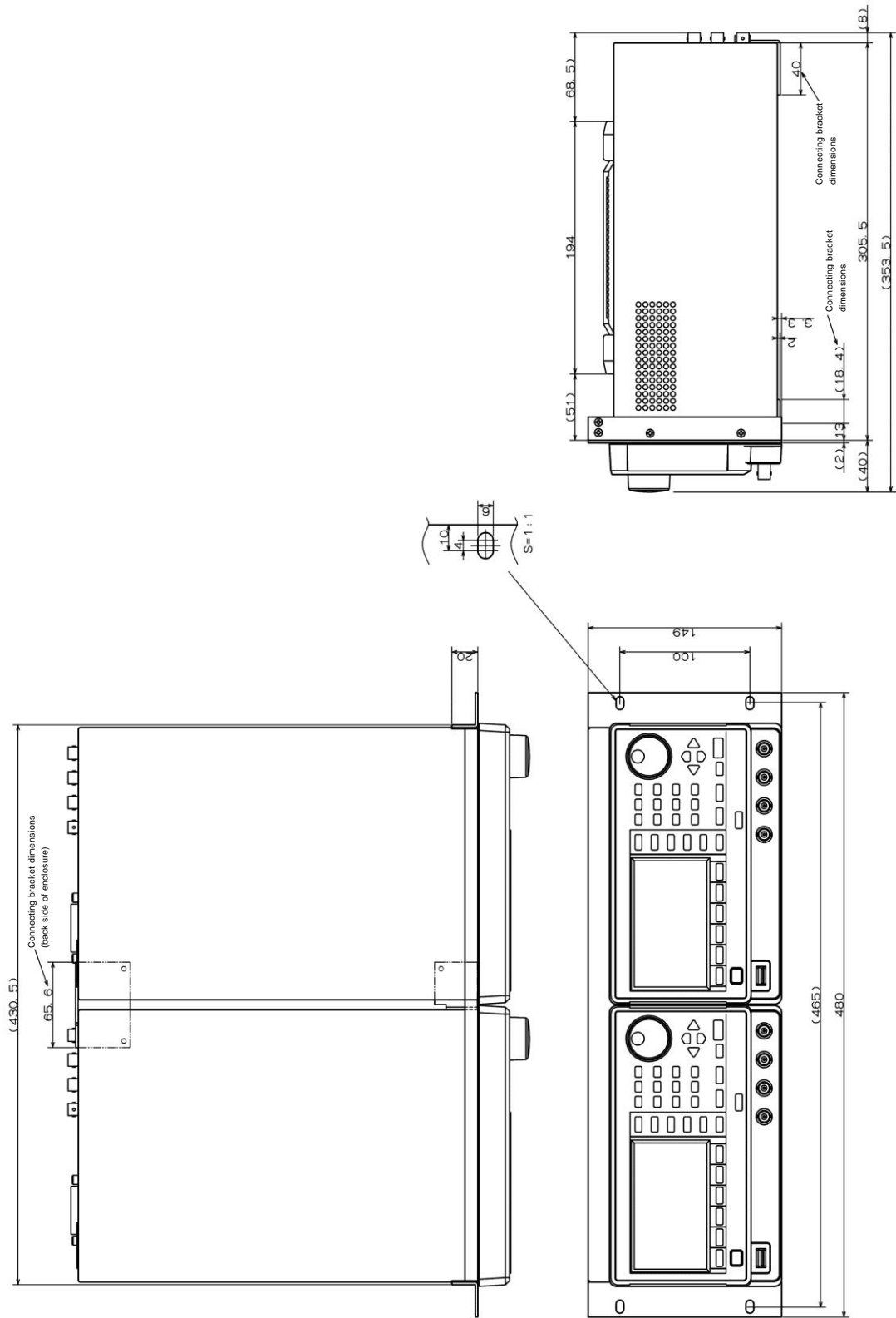

Surface treatment  
Rack mount adapters: Metallic gray paint

- Caution
- When mounting the unit in the rack, do not hold it only with the rack-mount adapters.
  - Be sure to hold the main unit with brackets or shelves on the rack side.



# WARRANTY

NF CORPORATION certifies that this product was thoroughly tested and inspected and found to meet its published specifications when it was shipped from our factory.

All NF products are warranted against defects in materials and workmanship for a period of five years from the date of shipment. During the warranty period, NF will repair the defective product without any charge for the parts and labor, or either repair or replace products which prove to be defective. For repair service under warranty, the product must be returned to either NF or an agent designated by NF. Purchaser shall prepay all shipping cost, duties, and taxes for the product to NF from another country, and NF shall pay shipping charge to return the product to purchaser.

This warranty shall not apply to any defect, failure or damage caused by improper use, improper or inadequate maintenance and care or modified by purchaser or personnel other than NF corporation.

**NF Corporation**

## REPAIR

When a failure occurred and the product was found to be defective or you have any uncertainty, please get in touch with NF Corporation or one of our representatives.

In such a case, let us know the model name (or product name), serial number (SERIAL No. given on the nameplate), and symptom and operating conditions as detail as possible.

Though we will make efforts to reduce the repair period, when five or more years have passed since you purchased the product, it may take time due to, for instance, the out of stock of repair parts.

Also, if the production of repair parts is discontinued, the product is extremely damaged, or the product is modified, we may decline the repair.

If there are any misplaced or missing pages, we will replace the manual. Contact the sales representative.

---

## NOTES

---

- Reproduction of the contents of this manual is forbidden by applicable laws.
- The contents of this manual may be revised without notice.
- Information provided in this manual is intended to be accurate and reliable.

However, we assume no responsibility for any damage regarding the contents of this manual.

- We assume no responsibility for influences resulting from the operations in this manual.
- 

## WF1967/WF1968 Instruction Manual (Operation)

### **NF Corporation**

6-3-20 Tsunashima Higashi, Kohoku-ku, Yokohama 223-8508, JAPAN

Phone: +81-45-545-8111 Fax: +81-45-545-8187

<http://www.nfcorp.co.jp/>

© Copyright 2022 **NF Corporation**

