

ScanIR3 Linescanner



Operating Instructions



Rev. A1 Mar 2015
60901

Contacts

Worldwide Headquarters

Santa Cruz, CA USA

Tel: +1 800 227 – 8074 (USA and Canada only)

+1 831 458 – 3900

Fax: +1 831 458 – 1239

info@ircon.com

European Headquarters

Berlin, Germany

Tel: +49 30 4 78 00 80

info@ircon.eu

Fluke Service Center

Beijing, China

Tel: +86 10 6438 691

Tel: +86 10 4008103435 (Service)

info@ircon.com.cn

Internet: <http://www.ircon.com/>

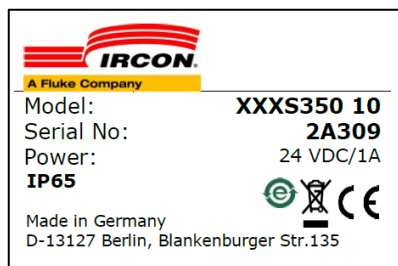

Linescanner

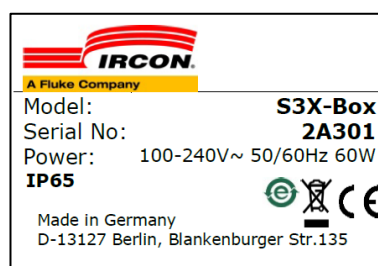

Processor Box

© Ircan, Inc.

Ircan is a registered trademark of Ircan, Inc.

All rights reserved. Specifications subject to change without notice.

WARRANTY

The manufacturer warrants this instrument to be free from defects in material and workmanship under normal use and service for the period of two years from date of purchase. This warranty extends only to the original purchaser. This warranty shall not apply to fuses, batteries, or any product which has been subject to misuse, neglect, accident, or abnormal conditions of operation.

In the event of failure of a product covered by this warranty, the manufacturer will repair the instrument when it is returned by the purchaser, freight prepaid, to an authorized Service Facility within the applicable warranty period, provided manufacturer's examination discloses to its satisfaction that the product was defective. The manufacturer may, at its option, replace the product in lieu of repair. With regard to any covered product returned within the applicable warranty period, repairs or replacement will be made without charge and with return freight paid by the manufacturer, unless the failure was caused by misuse, neglect, accident, or abnormal conditions of operation or storage, in which case repairs will be billed at a reasonable cost. In such a case, an estimate will be submitted before work is started, if requested.

THE FOREGOING WARRANTY IS IN LIEU OF ALL OTHER WARRANTIES, EXPRESSED OR IMPLIED, INCLUDING BUT NOT LIMITED TO ANY IMPLIED WARRANTY OF MERCHANTABILITY, FITNESS, OR ADEQUACY FOR ANY PARTICULAR PURPOSE OR USE. THE MANUFACTURER SHALL NOT BE LIABLE FOR ANY SPECIAL, INCIDENTAL OR CONSEQUENTIAL DAMAGES, WHETHER IN CONTRACT, TORT, OR OTHERWISE.

SOFTWARE WARRANTY

The manufacturer does not warrant that the software described herein will function properly in every hardware and software environment. This software may not work in combination with modified or emulated versions of Windows operating environments, memory-resident software, or on computers with inadequate memory. The manufacturer warrants that the program disk is free from defects in material and workmanship, assuming normal use, for a period of one year. Except for this warranty, the manufacturer makes no warranty or representation, either expressed or implied, with respect to this software or documentation, including its quality, performance, merchantability, or fitness for a particular purpose. As a result, this software and documentation are licensed "as is," and the licensee (i.e., the User) assumes the entire risk as to its quality and performance. The liability of the manufacturer under this warranty shall be limited to the amount paid by the User. In no event shall the manufacturer be liable for any costs including but not limited to those incurred as a result of lost profits or revenue, loss of use of the computer software, loss of data, the cost of substitute software, claims by third parties, or for other similar costs. The manufacturer's software and documentation are copyrighted with all rights reserved. It is illegal to make copies for another person.

Specifications subject to change without notice.



The device complies with the requirements of the European Directives.
EC – Directive 2004/108/EC (EMC)



Electromagnetic Compatibility Applies to use in Korea only. Class A Equipment
(Industrial Broadcasting & Communication Equipment)
This product meets requirements for industrial (Class A) electromagnetic wave equipment and the seller or user should take notice of it. This equipment is intended for use in business environments and is not to be used in homes.

Content

CONTENT	5
1 SAFETY INSTRUCTIONS	7
2 TECHNICAL DATA	10
2.1 MEASUREMENT SPECIFICATIONS	10
2.2 OPTICAL SPECIFICATIONS	11
2.2.1 <i>Optical Diagrams</i>	13
2.3 ELECTRICAL SPECIFICATIONS.....	14
2.4 GENERAL SPECIFICATIONS	14
2.5 DIMENSIONS	15
2.6 SCOPE OF DELIVERY.....	16
3 BASICS	17
3.1 MEASUREMENT OF INFRARED TEMPERATURES	17
3.2 EMISSIVITY OF TARGET OBJECT	17
4 SYSTEM OVERVIEW	18
5 INSTALLATION	19
5.1 PRE-INSTALLATION	19
5.1.1 <i>Ambient Temperatures</i>	19
5.1.2 <i>Environment</i>	19
5.1.3 <i>Electrical Interference</i>	19
5.1.4 <i>Geometry</i>	19
5.2 MOUNTING	20
5.3 WIRING	21
5.3.1 <i>Overview</i>	21
5.3.2 <i>Cable Entry System</i>	23
5.3.3 <i>Scanner Head Cable</i>	24
5.3.4 <i>Input/Output Modules</i>	25
5.3.5 <i>AC Mains</i>	25
5.4 COMMUNICATION INTERFACES	27
5.4.1 <i>Ethernet Settings</i>	27
5.4.2 <i>Changing the Ethernet Settings for the PC</i>	28
5.4.3 <i>Changing the Ethernet Settings for the Scanner</i>	30
5.5 WARM-UP TIME.....	31
5.6 WATER COOLING.....	31
5.6.1 <i>Avoiding Condensation</i>	31
5.7 AIR PURGE COLLAR.....	33
5.8 LASER.....	33
6 OPERATION	34
6.1 SCAN RATE AND TARGET VIEWING TIME.....	34
6.2 SECTORS	35
6.3 DATA TRANSFER MODES.....	36
7 ACCESSORIES	37
7.1 OVERVIEW.....	37
7.2 ADJUSTABLE MOUNTING BASE	38

7.3 TUBE FITTINGS.....	39
7.3.1 <i>Installation of the Tube Fittings</i>	39
7.3.2 <i>Reassembly of the Tube Fittings</i>	39
7.4 SPARE WINDOWS	40
7.5 REPLACEMENT KIT FOR SCANIR2 COOLING HOUSING.....	41
7.6 FIBER OPTIC / RJ45 ETHERNET CONVERTER	45
8 MAINTENANCE.....	46
8.1 REMOVING THE ADAPTER HOUSING.....	47
8.2 CLEANING THE WINDOW	48
8.3 REPLACING THE WINDOW	48
9 TROUBLESHOOTING	50
10 APPENDIX.....	52
10.1 DETERMINATION OF EMISSIVITY.....	52
10.2 TYPICAL EMISSIVITY VALUES.....	52

INDEX

1 Safety Instructions

This document contains important information, which should be kept at all times with the instrument during its operational life. Other users of this instrument should be given these instructions with the instrument. Updates to this information must be added to the original document. The instrument can only be operated by trained personnel in accordance with these instructions and local safety regulations.

Acceptable Operation

This instrument is intended only for temperature measurement and is appropriate for continuous use. The instrument operates reliably in demanding conditions, such as in high environmental temperatures, as long as the documented specifications are adhered to. Compliance with the operating instructions is necessary to ensure the expected results.

Unacceptable Operation













The instrument should not be used for medical diagnosis.

Replacement Parts and Accessories

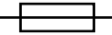
Use only original parts and accessories approved by the manufacturer. The use of other products can compromise the operational safety and functionality of the instrument.

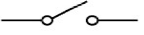
Safety Instructions

Safety Symbols

	AC (Alternating Current)
	DC (Direct Current)
	Hazardous voltage
	Risk of danger. Important information. See manual
	Helpful information regarding the optimal use of the instrument
	Earth ground
	Protective ground
	Fuse
	Normally-open (NO) relay
	Normally-closed (NC) relay
	Switch or relay contact
	DC power supply
CAT I	Measurement Category I
CE	Conforms to European Union directive
	Disposal of old instruments should be handled according to professional and environmental regulations as electronic waste.
	Conforms to relevant South Korean EMC Standards.

Safety Instructions



To prevent possible electrical shock, fire, or personal injury follow these guidelines:

- Read all safety information before you use the product.
- Use the product only as specified, or the protection supplied by the product can be compromised.
- Read all instructions.
- Do not use and disable the product if it is damaged.
- Do not use the product if it operates incorrectly.
- Make sure the ground conductor in the mains power cord is connected to a protective earth ground. Disruption of the protective earth could put voltage on the chassis that could cause death.
- Replace the mains power cord if the insulation is damaged or if the insulation shows signs of wear.
- Use in 110/230 VAC electrical systems can result in electrical hazards and personal injury, if not properly protected. All instrument parts supplied by electricity must be covered to prevent physical contact and other hazards at all times.
- The system integrator is responsible for the final safety of the system.

Technical Data

2 Technical Data

2.1 Measurement Specifications

Temperature Range

S330	20 to 350°C (68 to 662°F)
S339	100 to 800°C (212 to 1472°F)
S335	100 to 650°C (212 to 1202°F)
S350	100 to 950°C (212 to 1742°F)
S34x	30 to 250°C (86 to 482°F) – for S343 100 to 350°C (212 to 662°F) – for S344
S320	400 to 950°C (752 to 1742°F)
S310	600 to 1200°C (1112 to 2192°F)

Spectral Response

S330	3 to 5 μm
S339	3.9 μm
S335	3.5 to 4 μm
S350	5 μm
S34x	3.43 μm
S320	1.6 μm
S310	1 μm

Detectors

S330, S339, S335, S350, S34x	MCT
S320	InGaAs
S310	Si

System Accuracy¹

S330	$\pm 2^\circ\text{C}$ ($\pm 4^\circ\text{F}$)
S339	$\pm 0.5\%$ of reading or $\pm 3^\circ\text{C}$ (6°F), whichever is greater
S335	$\pm 0.5\%$ of reading or $\pm 3^\circ\text{C}$ (6°F), whichever is greater
S350	$\pm 0.5\%$ of reading or $\pm 3^\circ\text{C}$ (6°F), whichever is greater
S34x	$\pm 3^\circ\text{C}$ ($\pm 6^\circ\text{F}$)
S310, S320	$\pm 0.5\%$ of reading or $\pm 3^\circ\text{C}$ (6°F), whichever is greater

Repeatability²

S330	$\pm 1^\circ\text{C}$ ($\pm 2^\circ\text{F}$)
S339	$\pm 1^\circ\text{C}$ ($\pm 2^\circ\text{F}$)
S335	$\pm 1^\circ\text{C}$ ($\pm 2^\circ\text{F}$)
S350	$\pm 1^\circ\text{C}$ ($\pm 2^\circ\text{F}$)
S34x	$\pm 1^\circ\text{C}$ ($\pm 2^\circ\text{F}$)
S310, S320	$\pm 2^\circ\text{C}$ ($\pm 4^\circ\text{F}$)

¹ at 0 - 50°C (32 - 122°F) ambient temperature

² at 0 - 50°C (32 - 122°F) ambient temperature

Temperature Resolution

digital interface	0.1 K
analog output	16 bit

Scan Rate

All models	150 Hz in steps of: 20 Hz, 36 Hz, 48 Hz, 76 Hz, 85 Hz, 108 Hz, 126 Hz, 150 Hz
------------	--

Measured Points per Line¹

All models	256 pixel @ 150 Hz scan rate 512 pixel @ 76 Hz scan rate 1024 pixel @ 36 Hz scan rate – model as option
------------	---

Scan Angle (FOV)

All models	90°
------------	-----

2.2 Optical Specifications

Standard Focal Distance

All models	1.52 m / 69 in. (standard focus) special focal distances available minimal focal distance: 500 mm (20 in)
S335	∞ (far focus)

Optical Resolution D:S²

Measurement Resolution (90% energy)

S330, S339, S335, S350	170 : 1 (IFOV = 5.9 mrad)
S34x	33 : 1 – for S343 (IFOV = 30 mrad) 75 : 1 – for S344 (IFOV = 13.3 mrad)
S310	200 : 1 (IFOV = 5 mrad)
S320	200 : 1 (IFOV = 5 mrad)

Hot Spot Detection (50% energy)

S330, S339, S335, S350	510 : 1 (IFOV = 2 mrad)
S34x	100 : 1 – for S343 (IFOV = 10 mrad) 225 : 1 – for S344 (IFOV = 4.5 mrad)
S310	600 : 1 (IFOV = 1.7 mrad)
S320	600 : 1 (IFOV = 1.7 mrad)

¹ at 90° scan angle

² measured as slit response at 20 Hz scan rate, per pixel at focus distance

Technical Data

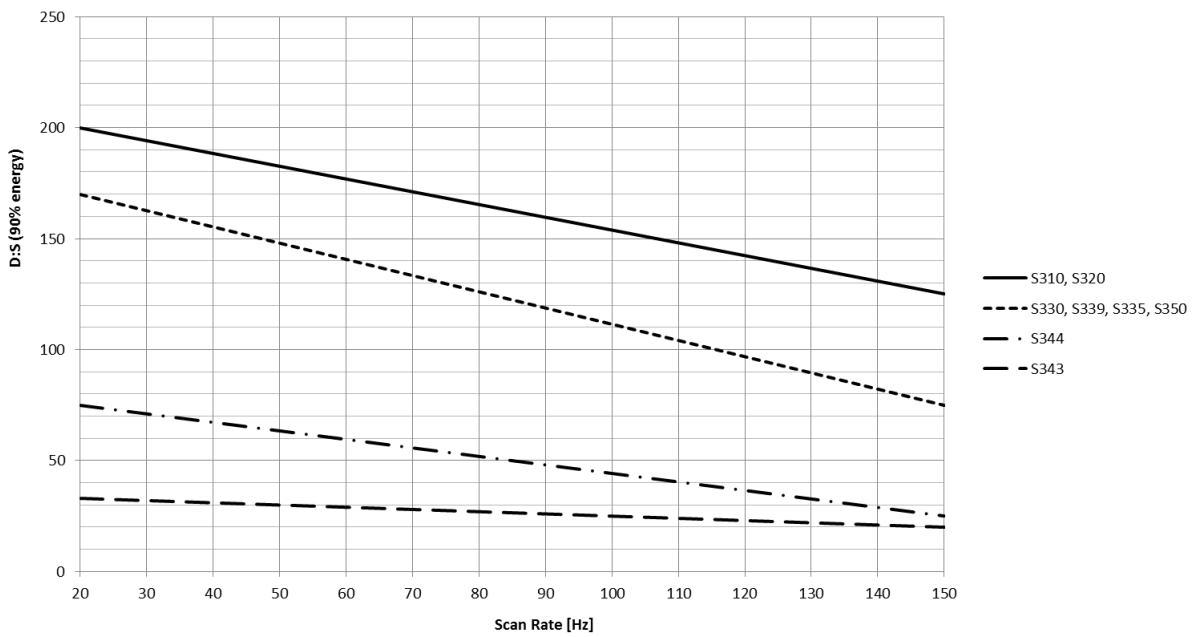

Figure 1: Optical Resolution for Measurement Resolution depending on Scan Rate

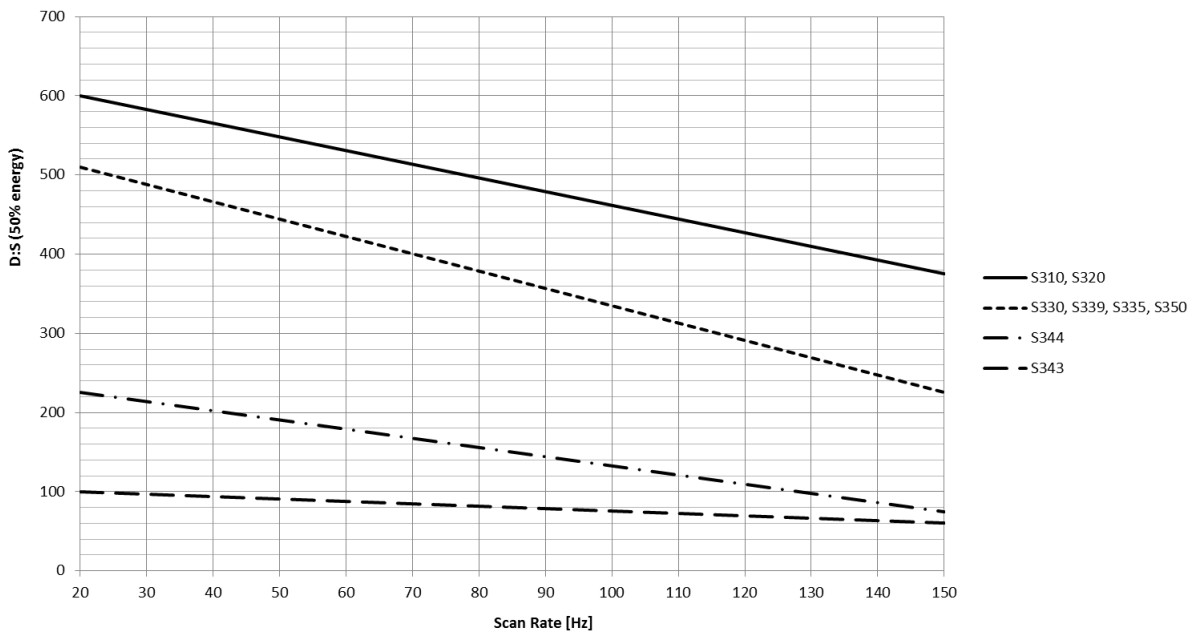

Figure 2: Optical Resolution for Hot Spot Detection depending on Scan Rate

2.2.1 Optical Diagrams

The focus distance is measured from the front end of the scanner!

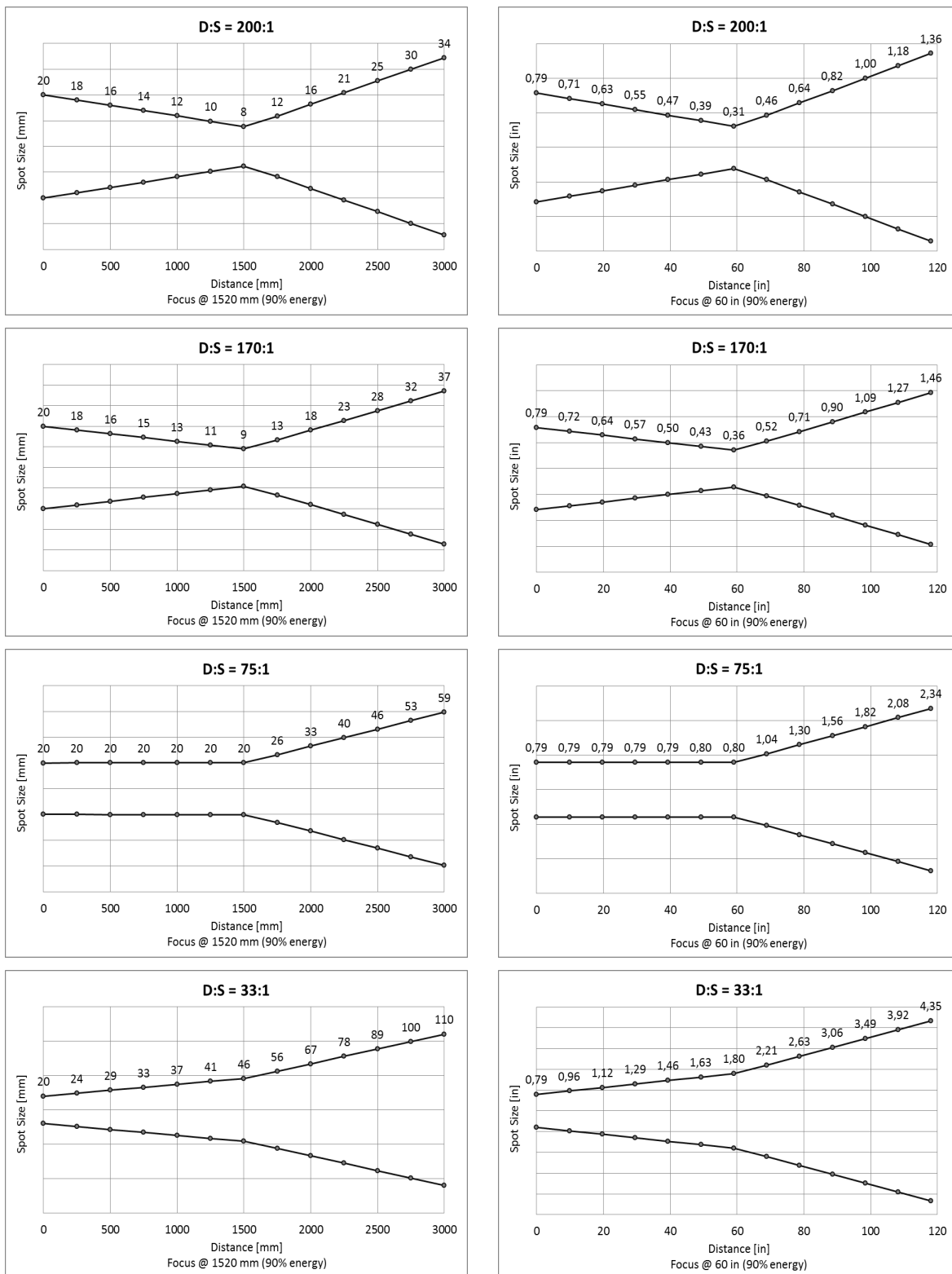

Figure 3: Diagrams for selected Optical Resolutions (90% energy)

Technical Data

2.3 Electrical Specifications

Communications

Ethernet TCP/IP protocol 10/100 MBit/s, electrically isolated auto-negotiation

Inputs

Trigger + 5 to 24 VDC pulse, high/low active
Functional Input max. + 5 VDC
function depends on the specific linescanner system

Signal Processing

Stand-alone unit Max, Min, Average, Peak/Valley Hold, Alarm setpoints further signal processing function through software

Power

AC Power 100 to 240 VAC, 50/60 Hz, 0.6 A
Altitude: 2000 m (6562 ft)

Terminal Wiring

AC Power 1.5 mm² (AWG 16) to 2.5 mm² (AWG 14)
I/O Modules 1.5 mm² (AWG 16)

2.4 General Specifications

Mechanical Scanning System 40,000 h (about 4.5 years) meantime between failures (MTBF) for the mechanical scanning system at 48 Hz scan rate

Environment Rating IP65 (NEMA 4) in accordance to IEC 60529

Ambient Temperatures¹

All models 0 to 50°C (32 to 122°F) – without cooling
max. 180°C (356°F) – with integrated water cooling (standard)
S335 down to -40°C (-40°F) with internal heating element
optional for all other scanner models

Storage Temperatures -25 to 65°C (-13 to 149°F)

Water Cooling: Pressure max. 15 bar (218 PSI)

Water Cooling: Flow rate typ. 1 l / min to 2 l / min (0.26 to 0.52 gallons / min)

Air Purge Collar: Pressure max. 3 bar (43 psig)

Air Purge Collar: Flow rate typ. 100 l/min to 200 l/min (3.53 to 7.06 cfm)

Warm-up Time 30 min.

Relative Humidity 10 to 90%, non-condensing,
for operating and non-operating temperature range

Vibration IEC 60068-2-6, 3 axes, 10 to 150 Hz, operating 2 g above 20 Hz

Shock IEC 60068-2-27, 3 axes, operating: 5 g at 11 ms, 15 g at 6 ms

¹ at still air (e.g. by using a protective housing)

Head Cable

Cable material	FEP (oil resistant)
Cable gland	stainless steel (1.4305 / AISI 303)
Ambient temperature	-50 to 180°C (-58 to 356°F)
Outer diameter	11.3 mm (0.44 in)
Minimal bending radius	135 mm/5.3 in (moved) 85 mm 3.3 in (non-moved)

Processor Box

Temperature Range	0 to 50°C (32 to 122°F); -30°C (-22°F) with internal heater
Material	sheet steel, powder-coated
Dimensions (W x H x D)	380 x 380 x 210 mm (15 x 15 x 8.3 in)
Net Weight	approx. 12 kg (26 lb)
Protection Rate:	IP66 (NEMA 4)

2.5 Dimensions

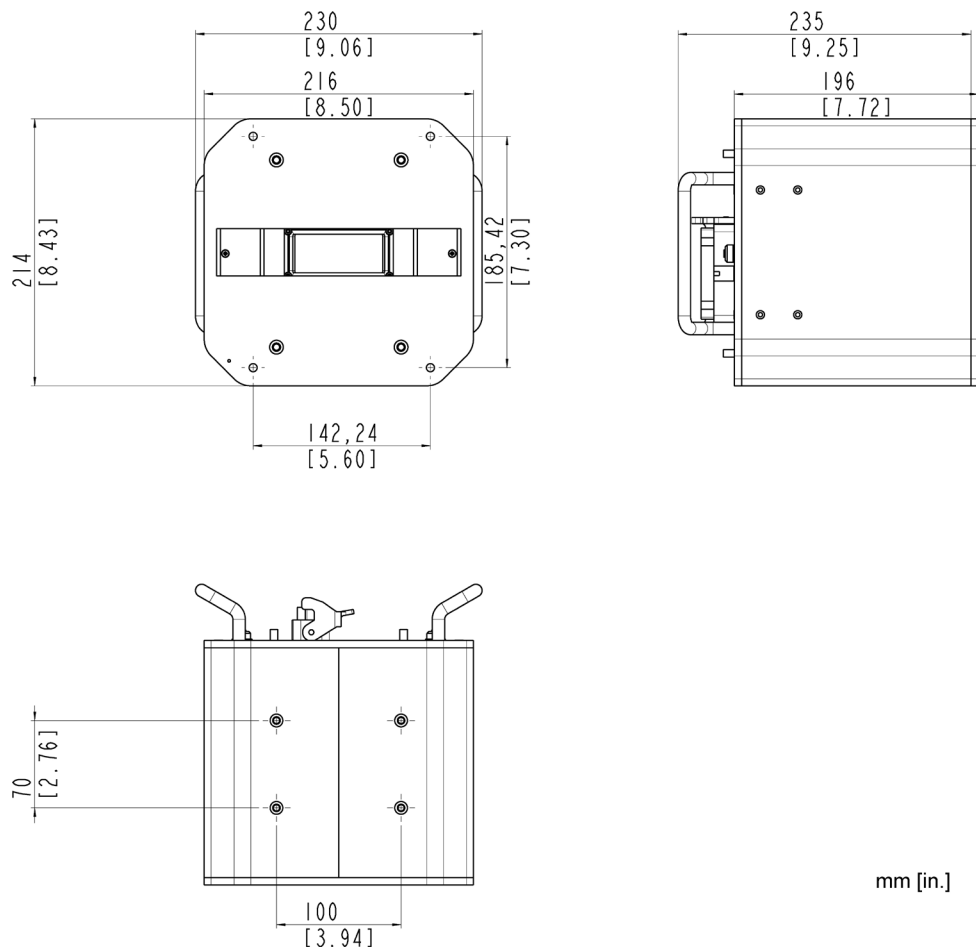

Figure 4: Linescanner Dimensions

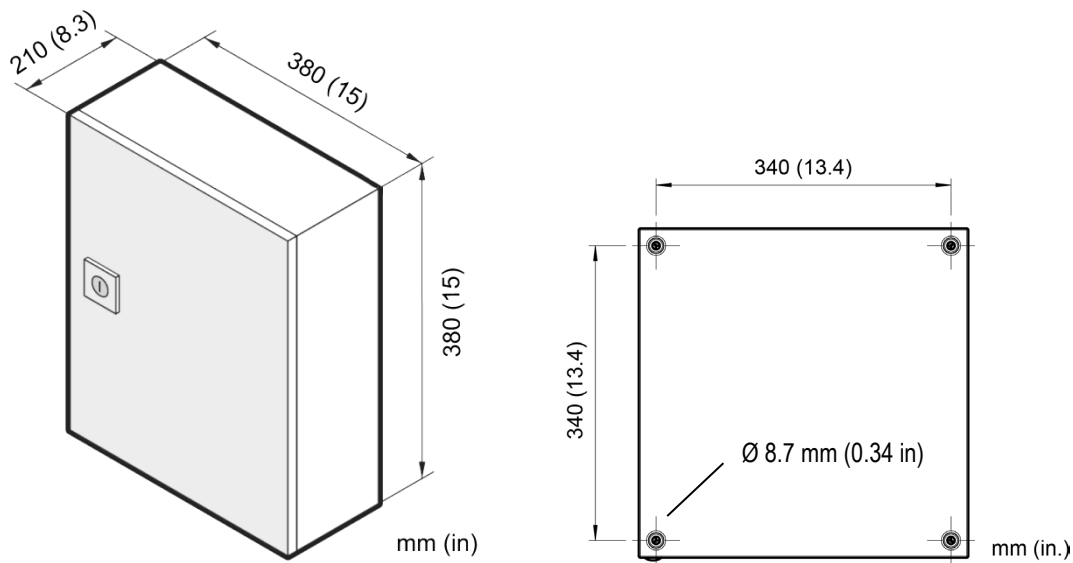

Figure 5: Footprint for the Processor Box

2.6 Scope of Delivery

The linescanner package includes the following:

- ScanIR3 Linescanner with head cable
- Processor box with internal power supply
- Operating Instructions (also included as PDF file on the CD-ROM)
- Software CD with ScanView Pro
- Protocol Manual only as PDF file on the CD-ROM
- 1x spare window
- Tools:
 - 1x hex key wrench 2.5 mm (0.1 in)
 - 1x hex key wrench 3 mm (0.12 in)
 - 1x hex key wrench 4 mm (0.16 in)
 - 1x hex key wrench 5 mm (0.2 in)

3 Basics

3.1 Measurement of Infrared Temperatures

Every object emits an amount of infrared radiation (IR) according to its surface temperature. The intensity of the infrared radiation changes with the temperature of the object. Depending on the material and surface properties, the emitted radiation lies in a wavelength spectrum of approximately 1 to 20 μm . The intensity of the infrared radiation ("heat radiation") is dependent on the material. For many substances this material-dependent constant is known. It is referred to as "emissivity value", see appendix 10.2 [Typical Emissivity Values](#) on page 52.

Infrared thermometers are optical-electronic sensors. These sensors are able to detect "radiation of heat". Infrared thermometers consist of a lens, a spectral filter, a sensor, and an electronic signal processing unit. The task of the spectral filter is to select the wavelength spectrum of interest. The sensor converts the infrared radiation into an electrical signal. The connected electronics process this signal for further analysis. The intensity of the emitted infrared radiation is thereby used to determine the temperature of the target. Since the intensity of the infrared radiation is dependent on the material, the appropriate emissivity can be selected on the sensor.

The biggest advantage of the infrared thermometer is its ability to measure temperature without the need to be in contact with the target. Consequently, surface temperatures of moving or hard to reach objects can be easily measured.

3.2 Emissivity of Target Object

For accurate temperature readings, the sensor must be set to the appropriate emissivity value for the target material. Determine the emissivity of the target object as described in appendix 10.1 [Determination of Emissivity](#) on page 52.

When measuring materials with low emissivity, the results could be affected by interfering infrared radiation from background objects (such as heating systems, flames, fireclay bricks, etc. near to or behind the target object). This type of problem can occur when measuring reflective surfaces and very thin materials such as plastic films and glass. This error can be reduced to a minimum if particular care is taken during installation, and the linescanner is shielded from reflected infrared radiation.

Contact the manufacturer for more information.

System Overview

4 System Overview

The following figure shows the principal structure of the system. It shows a system with a linescanner, the sensor cable and the processor box. The processor box supports the interfacing capabilities like analog or digital outputs and provides optionally glass fiber communication.

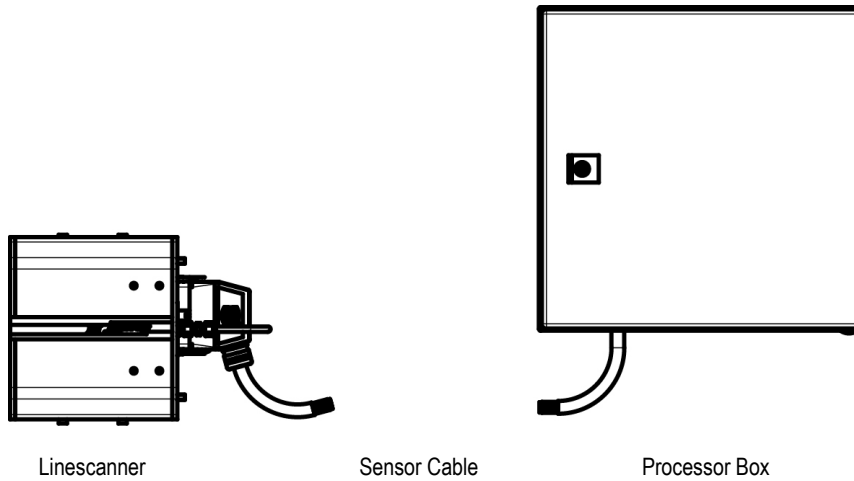

Figure 6: Principal structure of the system

Linescanners are able to measure temperature values along a line through the use of a rotating mirror. For 25% of its revolution, the linescanner scans the field of view (FOV). This corresponds to a scan angle of 90°. The remaining 75% of its revolution is used for the internal operation of the sensor. The rotating mirror views the scene and reflects the infrared energy striking it onto a system of lenses which focuses the radiation onto a thermoelectrically cooled detector. The incoming signal is scanned, digitized, and then converted to temperature values by the internal microprocessor. For every revolution of the mirror, up to 1024 measured values will be internally collected. An air purge system keeps the scanner's window free of dust, debris, and condensation.

5 Installation

5.1 Pre-Installation

The following guidelines will help in planning the installation of the scanner system.



When this instrument is being used in a critical process that could cause property damage and personal injury, the user should provide a redundant device or system that will initiate a safe process shut-down in the event that this instrument should fail. The user should follow the appropriate safety guidelines!

5.1.1 Ambient Temperatures

Without water cooling, the linescanner is designed for ambient operating temperatures between 0°C and 50°C (32°F and 122°F). With water cooling, it can be used in environments of up to 180°C (356°F), see section 5.6 [Water Cooling](#), page 31. The internal temperature is the determining factor for proper operation of the linescanner. It is displayed in the ScanView Pro software. The difference between the external ambient temperature and the temperature inside the housing also depends on the thermal contact of the linescanner and its mounting hardware.



The temperature inside the housing must be between 0°C to 60°C (32°F to 140°F) during operation and never more than 65°C (150°F) at any time, including non-operation!

5.1.2 Environment

The linescanner complies with class IP65 and is therefore dust and splash resistant. The linescanner's window is made of a material that is resistant to thermal stresses and it is equipped with an integrated air purge system which protects the window against contamination. Air supply for the air purge should be oil free, clean "instrument" air.



For permanent outdoor installations, add an additional roof to the system to protect it from weather effects!

5.1.3 Electrical Interference

To minimize electrical or electromagnetic interference, follow these precautions:

- Mount the sensor as far away as possible from possible sources of interference such as motorized equipment producing large step load changes!
- Ensure a fully insulated installation of the sensor (avoid ground loops!).
- Make sure the shield wire in the sensor cable is earth grounded at one location!
- To avoid potential differences use a single power circuit to power both the linescanner and the PC running the software!

5.1.4 Geometry

The smallest possible object which can be measured depends on two conditions:

1. The area measured must be no less than 90% (90% energy response).

Installation

2. Hot spots must be clearly detected, when in front of a cold background (50% energy response).

Remark: The measured area for 50% energy response is approximately $\frac{1}{3}$ of the area size of the measured spot for 90% energy response.

Refer to section 2.2 [Optical Specifications](#), page 11, for basic versions of optical resolution values for the various models.

L = Scan line width
D = Distance to target (measured from front surface of housing)

90° FOV:
 $D = L/2$

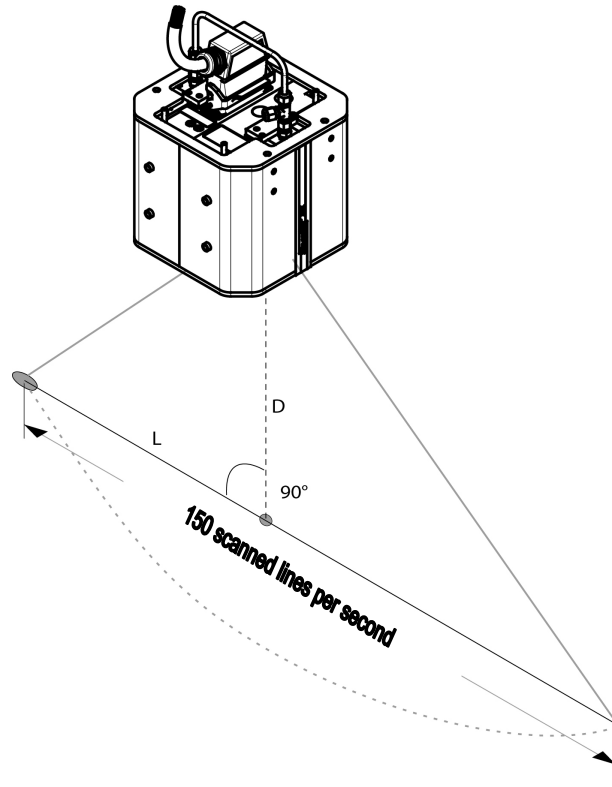

Figure 7: Relationship between scan line width and distance to target

The relationship between the scan line width (L) and the distance (D) to the front side of the linescanner housing is defined as described above. For long distances, the scan line width is about twice the measurement distance (90° FOV).

5.2 Mounting

The linescanner can be installed with the mounting holes of the linescanner housing. This type of setup is recommended for permanent installations where higher stability is desired.

Prevent all contact between heat sources and the linescanner to protect the linescanner from overheating.

5.3 Wiring

5.3.1 Overview



Prior to making any wiring connections ensure that AC power is off!

The processor box provides power and communication to the linescanner. For the processor box there are several output modules available offering analog or digital signals to the central control system see section 6.2 [Sectors](#), page 35. The processor box can be mounted 10 m (33 ft) away from the scanner with the standard scanner cable length, longer cables are available on request. The scanner cable between the linescanner and the processor box needs to be protected from mechanical damage. The cable withstands ambient temperatures up to 180°C (356°F).

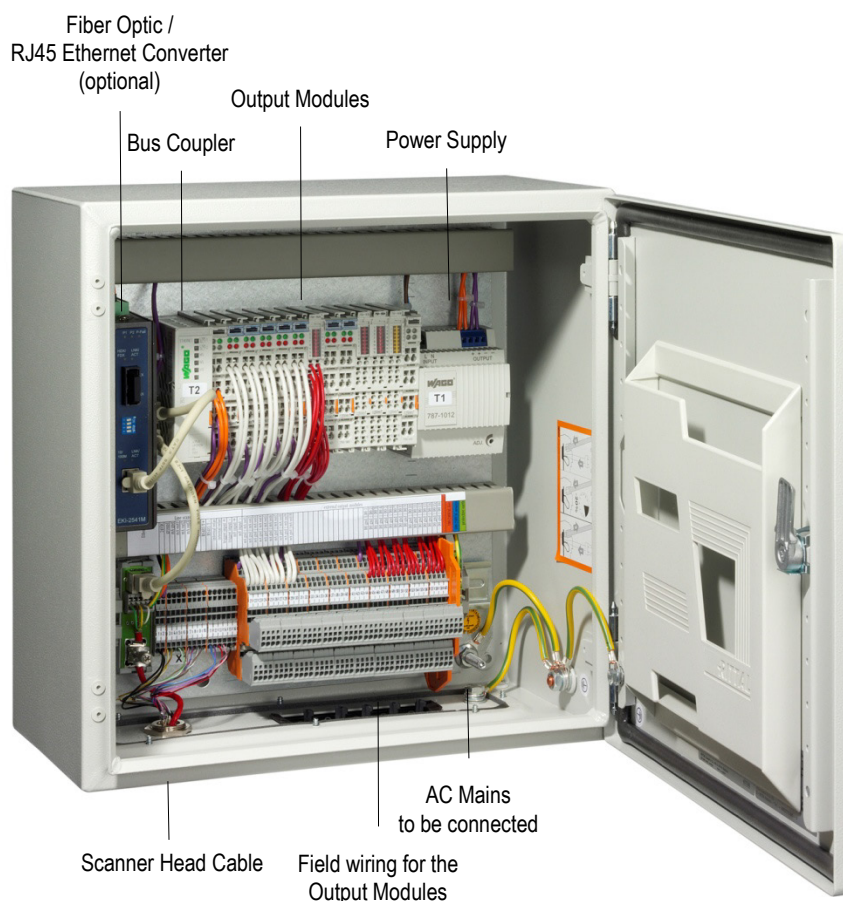

Figure 8: Opened Processor Box

Installation

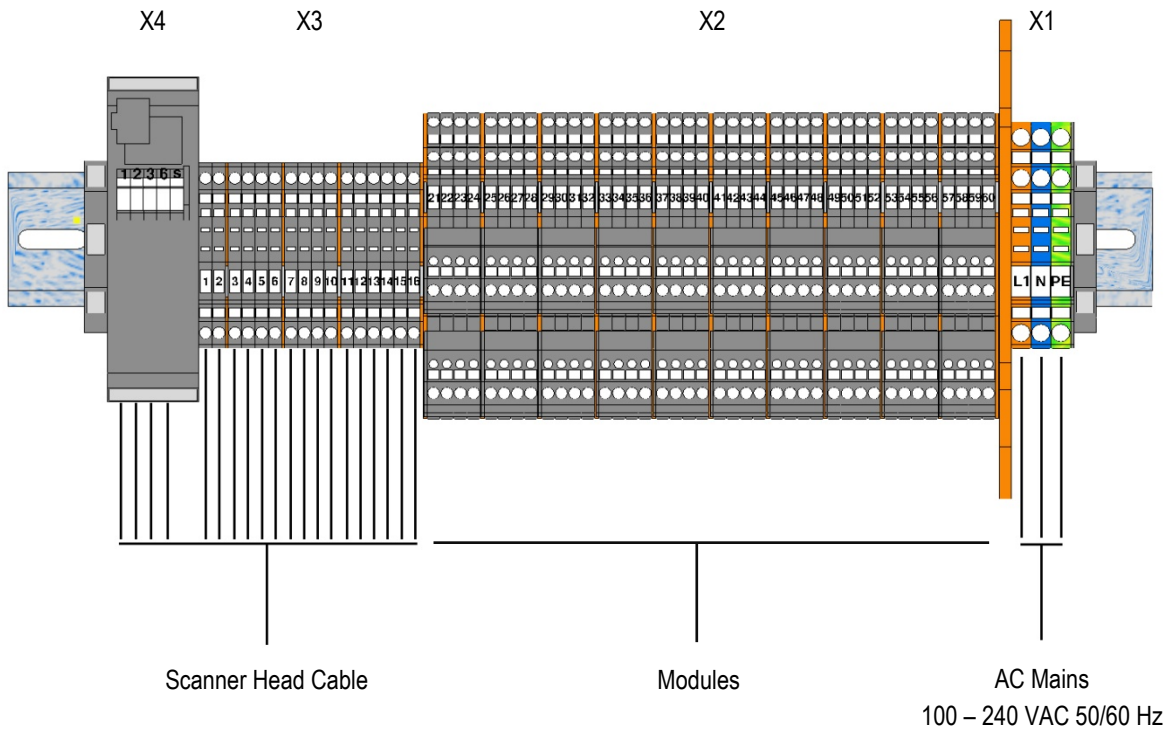
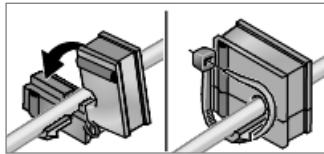

Figure 9: Terminal Line

5.3.2 Cable Entry System

The cable entry system is a split system that allows pre-assembled cables to be routed into the system connection box without disassembling the connectors.

Snap-on mounting¹



Lay cable into appropriate grommet and provide strain relief where necessary using cable ties.

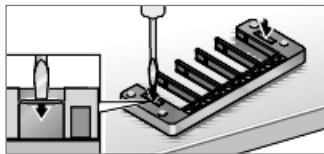

Use appropriate tool to punch through cover on base frame.

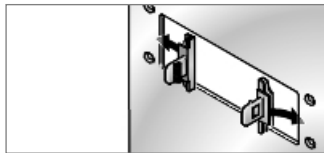

Set catch hooks into the sides of the cut-out.

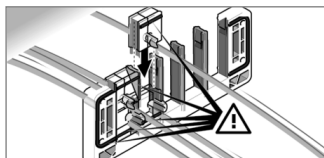

Insert rail completely.

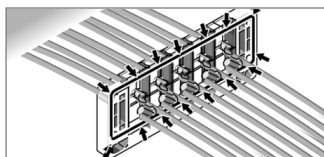

The grommet must produce a continuous seal on the back side.

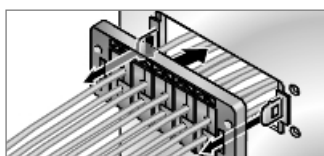

Set the rail onto the catch hooks and press on.

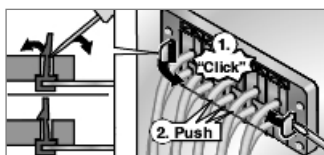

Lock the catch hooks with the rail. Press gently on grommet one more time.

¹ Illustrations: © Murrplastik

Installation

5.3.3 Scanner Head Cable

The scanner head cable comes pre-wired to the processor box by factory default.

Terminal	X4					X3															
Pin	1	2	3	6	S	1	2	3	4	5	6	7	8	9	10	11	12	13	14	15	16
Color	green	brown	yellow	white	yellow	black_1	black_2	yellow / white	yellow / brown	green / white	green / brown	pink / grey	blue / red	grey / white	grey / brown	blue	violet	red	pink	black	grey
Description	Ethernet					ground	24 VDC	for service only	for service only	for service only	for service only	for service only	for service only	for service only	for service only	internal relay	internal relay	trigger input +	trigger input -	mV input +	mV input -

Figure 10: Wiring the Scanner Head Cable

By standard, the cable gland is mounted to the scanner head cable. In case of specific installation needs, see the mounting structure for the cable gland below for detaching/attaching it.

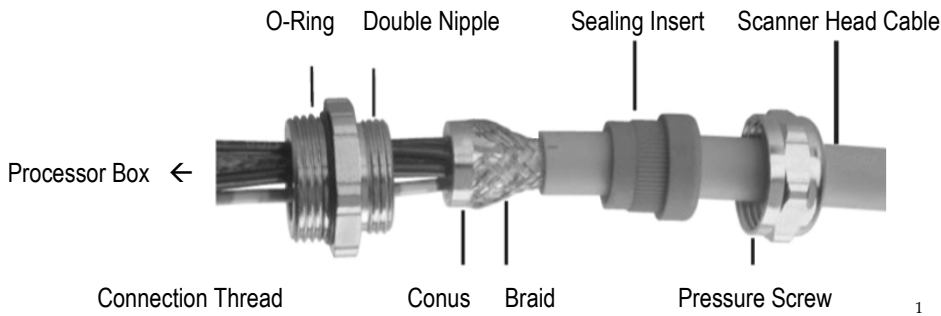

Figure 11: Cable Gland Composition

¹ © Pflitsch GmbH & Co. KG

5.3.4 Input/Output Modules

The processor box contains a terminal line which is labeled like shown below. It shows the maximal stage of expansion for the output modules from the wiring point of view.



Due to limited space, the maximal number of modules is restricted to 11!

X2						X2						X2																											
21	22	23	24	25	26	27	28	29	30	31	32	33	34	35	36	37	38	39	40	41	42	43	44	45	46	47	48	49	50	51	52	53	54	55	56	57	58	59	60
mA out1	mA out2	mA out3	mA out4	mA out5	mA out6	mA out7	mA out8	mA out9	mA out10	mA out11	mA out12	relay 1	relay 2	relay 3	relay 4	relay 5	relay 6	relay 7	relay 8	relay 9	relay 10	relay 11	relay 12	DO 1	DO 2	DO 3	DO 4	DO 5	DO 6	DO 7	DO 8	DO 9	DO 10	DO 11	DO 12	DO 13	DO 14	DO 15	DO 16
mA gnd	mA gnd	mA gnd	mA gnd	mA gnd	mA gnd	mA gnd	mA gnd	mA gnd	mA gnd	mA gnd	mA gnd	relay 1	relay 2	relay 3	relay 4	relay 5	relay 6	relay 7	relay 8	relay 9	relay 10	relay 11	relay 12	DO gnd	DO gnd	DO gnd	DO gnd	DO gnd	DO gnd	DO gnd	DO gnd	DO gnd	DO gnd	DO gnd	DO gnd	DO gnd	DO gnd	DO gnd	DO gnd
6 Output Modules, analog 2 channels each						6 Output Modules, Relay 2 channels each						1 Output Module, digital 16 channels																											

Figure 12: Exemplary Wiring the Output Modules

5.3.5 AC Mains

The processor box does not include a power switch. You must supply a mains disconnect switch. This switch should be in close proximity to the operator and clearly marked as the power shutoff for the equipment.

If you use a line conditioner or isolation transformer, connect per manufacturer's instructions. Observe grounding instructions and make sure earth ground is supplied to the terminal block of the processor box.



- A ground wire must be connected to the (protective earth) terminal.
- To prevent possible electrical shock, fire or personal injury make sure that the processor box is grounded before use.
- Follow all local electrical codes related to installation and grounding of electrical equipment.



To prevent personal injury, make sure the mains disconnect switch is off before opening the box lid.



The protective earth screw (marked with \oplus) and to be found on the bottom side of the processor box) requires the connection to the local ground by using a 16 mm² (AWG 6) green/yellow wire.

Installation

Terminal		X1	
Pin	L1	N	PE
	100-240 VAC live	100-240 VAC neutral	Protective Earth

Figure 13: AC Mains Cable

The Earth Ground wire should be slightly longer than the two other wires so if the cable is accidentally pulled the line and neutral wires are disconnected first.

You need to connect the AC mains. Use only cable with 3 wires in a size of 1.5 to 2.5 mm² (AWG 14 to 16).



An external 6 to 16 A line fuse (type B) or an equivalent circuit breaker is required for the AC mains installation.

5.4 Communication Interfaces

The linescanner communicates via Ethernet interface. The Ethernet connection between linescanner and the PC has a maximum speed of 100 MBit/s and permits real-time data transfer for all temperature pixels. For multi-scanner systems you can use a standard Ethernet Switch to connect to the PC network adapter.

5.4.1 Ethernet Settings

Scanner IP Address

The factory default IP address for the linescanner is 192.168.42.30.

The scanners address is not free of choice: It has to be unique in the network meaning that no other device in the network including the PC network adapter may run at the same IP address.



Ask your IT administrator for a free IP address to be used!

Advanced Ethernet Settings

Subnet Mask:

The Subnet Mask defines the interpretation of the IP address. The factory default setting is 255.255.255.0. The Subnet Mask can be changed using the <NM> command of the scanner.

Port:

In the case that the default scanners port (2727) should conflict with something else (it could be blocked by the firewall for example) it can be changed using the <PO> command of the scanner.

Gateway:

A gateway connects two subnets (which have a different subnet address). The IP address of this gateway is given with the route command <RO>. The default is RO0.0.0.0 - this does mean no gateway is set.



To establish the Ethernet communication, the subnet addresses for both the scanner and the PC need to match! Appropriate changes can be applied either on the scanner side or on the PC network adapter!

Installation



The current settings for the IP address and the netmask of the PC can be asked with the command `<ipconfig>` in a Command Prompt window!

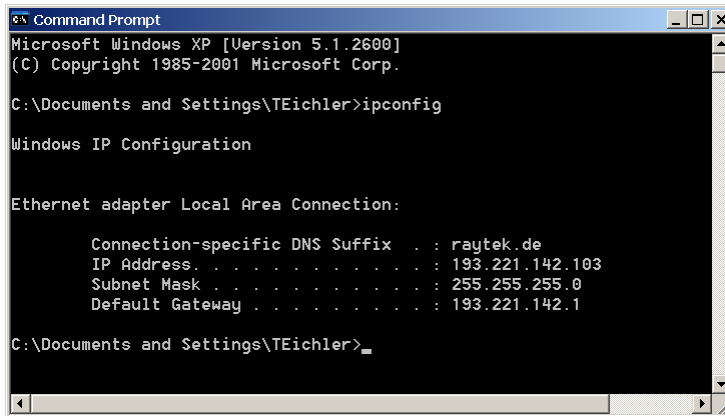

For the example above, the IP address of the PC is 193.221.142.103. The subnet address is 193.221.142, the host address is 103. The scanner's subnet address must be 193.221.142 as well. The host address of the scanner must be in the range from 1 to 254 with the exception of 103 which is already used for the PC.

5.4.2 Changing the Ethernet Settings for the PC

The network adapter on the PC side can be configured as following:

1. Go to `<Start> <Settings> <Network Connections> <Local Area Connection>`
2. Click on `<Properties>`:

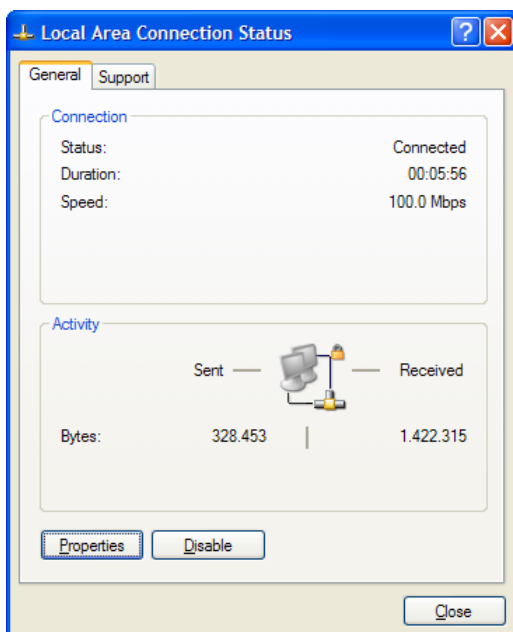

- Under <This connection uses the following items> select <Internet Protocol (TCP/IP)> and click on <Properties>:

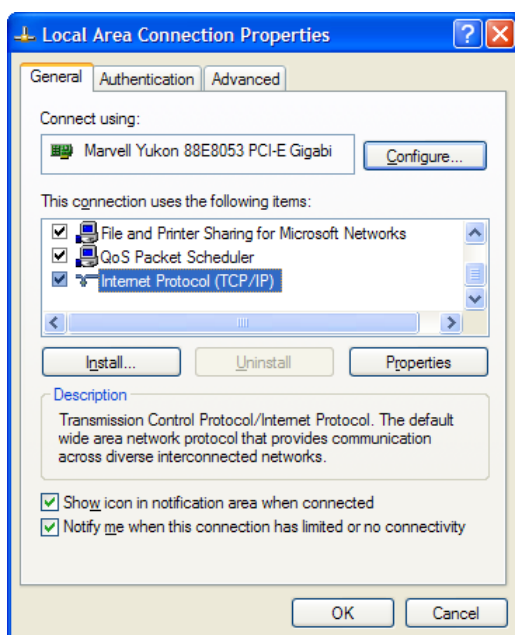

- Activate the radio button <Use the following IP address> and make the following settings:
IP address: 192.168.42.x
where x is an address between 0 and 255 except 30 which is already used by the linescanner by factory default
Subnet mask: 255.255.255.0
Default gateway: {empty}

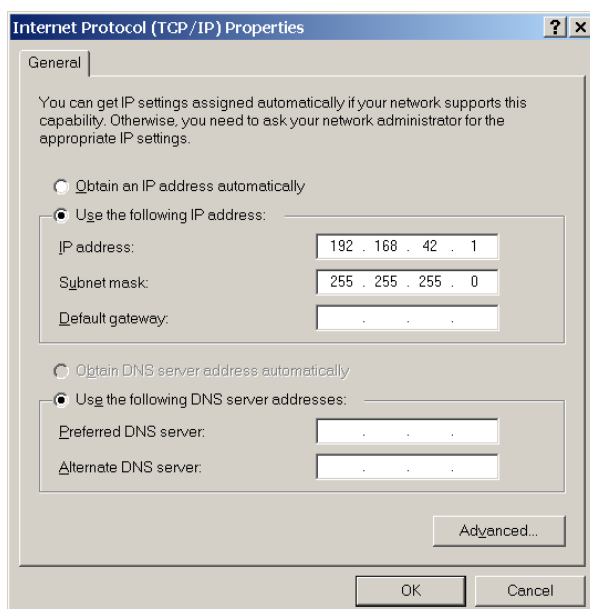

- Close all dialog boxes by pressing on <OK>.

Installation

5.4.3 Changing the Ethernet Settings for the Scanner

When using the linescanner on an Ethernet network you may need to change the IP address so that the factory default address does not conflict with another device on the network. Change the IP address following the procedure described below:

- Make sure that the PC network adapter is configured as required, see sections 5.4.1 [Ethernet Settings](#), page 27 and 5.4.2 [Changing the Ethernet Settings for the PC](#), page 28.
- Make sure that the scanner runtime software is stopped!
- Switch off the scanner!
- Switch on the scanner!
- Open the Command Prompt window and start a Telnet session by using the command:
`telnet <IPAddressScanner> <Port>`

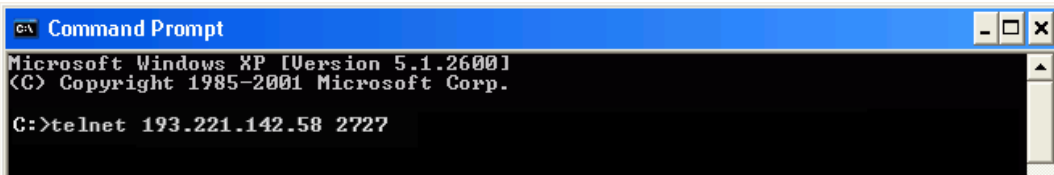

Windows 7 does not have Telnet enabled by default. Enable the Telnet Client by using the command: `pkgmgr /iu:"TelnetClient"`

- Under Telnet you have access to the scanner command level. Give the new IP address for the scanner with the command:
`IP<NewScannerIPAddress>`

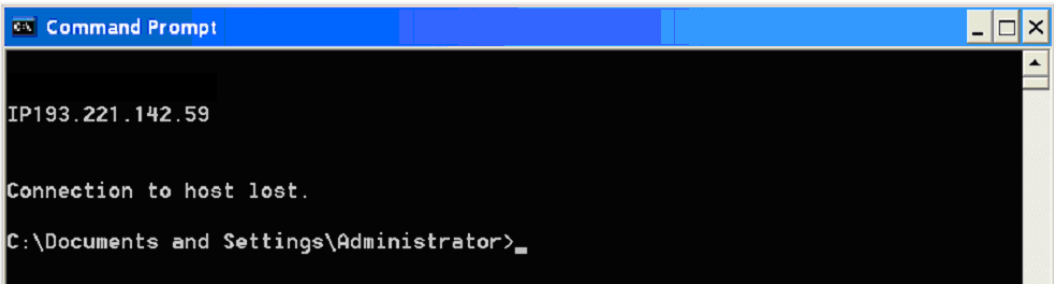

- With changing the IP address for the scanner you will immediately loose the connection, so you have to restart a further Telnet session by using the new IP address for the scanner:
`telnet <NewScannerIPAddress> <Port>`

- Save the new IP address permanently in the scanner with the command:
`PS`

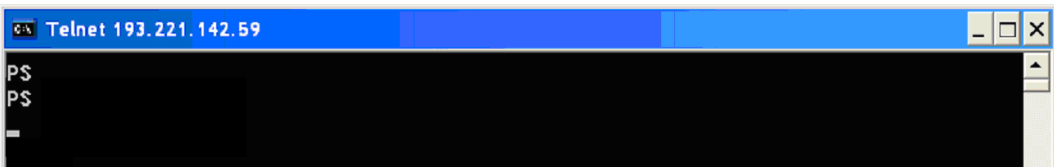

- Stopp the Telnet session by closing the DOS window. The Ethernet communication will be automatically closed.

5.5 Warm-Up time

For accurate temperature readings we recommend a 30 minute warm-up period after power on. During this time the internal calibration sources will be stabilized. Digital communication and the analog outputs can be started 60 seconds after power on.

5.6 Water Cooling

The linescanner is equipped with integrated stainless-steel pipes for water cooling. These pipes are embedded in the cast aluminum housing. The water cooling system enables the linescanner to be installed in high ambient temperatures. Only filtered water should be used in order to reduce the risk of clogging at the hose couplings. In order to prevent the accumulation of water condensation on the scanner window and to protect the window, the air purge system should always be used when water cooling is used.

Threaded tube fittings to connect a water cooling system are provided as accessory, see section 7.3 [Tube Fittings](#), page 39. The internal stainless steel tube is designed to mate to a hose with an internal diameter of 6 mm (0.24 in.).

The following table gives some examples for the efficiency of the water cooling system.

Ambient Temperature	Water Flow	Water Temperature at Inlet	Resulting Internal Temperature
180°C (356°F)	1 l / min (0.26 gallons / min)	25°C (77°F)	36°C (96.8°F)
180°C (356°F)	2 l / min (0.52 gallons / min)	15°C (59°F)	27°C (80.6°F)

Tab. 1: Efficiency of the water cooling system

5.6.1 Avoiding Condensation

If environmental conditions make water cooling necessary, it is strongly recommended to check for condensation on the interior of the scanner housing.

Water cooling also cools the air in the interior of the scanner housing thereby decreasing the capability of the air to store water. The relative humidity increases and can reach 100% very quickly. In case of additional cooling, the surplus water vapor will precipitate out as water (condensation) that will condense on the lenses and the electronics thereby causing device failure. Condensation can even occur with an IP65 sealed housing.



The presence of condensed water inside the housing will void the warranty!

There are several ways to prevent condensation:

1. Adjust the flow rate and check visually for moisture on the exterior of the housing. This method has a degree of risk if the moisture is not detected quickly.
2. Use a radiator or heat exchanger where the cooling fluid can be heated above the dew point.
3. Measure the ambient temperature and the relative humidity where the device has to be installed. Use the table below to get the **minimum** device temperature. If the temperature of the cooling fluid is much lower than the minimum device temperature, condensation can be expected. To avoid this, adjust the flow rate manually or use a thermostat to keep the device at a minimum temperature above the dew point.

Installation

		Relative Humidity [%]																			
		10	15	20	25	30	35	40	45	50	55	60	65	70	75	80	85	90	95	100	
Ambient Temperature [°C/°F]	0/ 32	0/ 32	0/ 32	0/ 32	0/ 32	0/ 32	0/ 32	0/ 32	0/ 32	0/ 32	0/ 32	0/ 32	0/ 32	0/ 32	0/ 32	0/ 32	0/ 32	0/ 32	0/ 32	0/ 32	
	5/ 41	0/ 32	0/ 32	0/ 32	0/ 32	0/ 32	0/ 32	0/ 32	0/ 32	0/ 32	0/ 32	0/ 32	0/ 32	0/ 32	0/ 32	0/ 32	0/ 32	0/ 32	0/ 32	5/ 41	
	10/ 50	0/ 32	0/ 32	0/ 32	0/ 32	0/ 32	0/ 32	0/ 32	0/ 32	0/ 32	0/ 32	0/ 32	0/ 32	0/ 32	5/ 41	5/ 41	5/ 41	5/ 41	5/ 41	5/ 41	10/ 50
	15/ 59	0/ 32	0/ 32	0/ 32	0/ 32	0/ 32	0/ 32	0/ 32	0/ 32	0/ 32	5/ 41	5/ 41	5/ 41	5/ 41	5/ 41	10/ 50	10/ 50	10/ 50	10/ 50	10/ 50	15/ 59
	20/ 68	0/ 32	0/ 32	0/ 32	0/ 32	0/ 32	0/ 32	5/ 41	5/ 41	5/ 41	10/ 50	10/ 50	10/ 50	10/ 50	15/ 59	15/ 59	15/ 59	15/ 59	15/ 59	15/ 59	20/ 68
	25/ 77	0/ 32	0/ 32	0/ 32	0/ 32	5/ 41	5/ 41	10/ 50	10/ 50	10/ 50	10/ 50	15/ 59	15/ 59	15/ 59	20/ 68	20/ 68	20/ 68	20/ 68	20/ 68	20/ 68	25/ 77
	30/ 86	0/ 32	0/ 32	0/ 32	5/ 41	5/ 41	10/ 50	10/ 50	15/ 59	15/ 59	15/ 59	20/ 68	20/ 68	20/ 68	25/ 77	25/ 77	25/ 77	25/ 77	25/ 77	25/ 77	30/ 86
	35/ 95	0/ 32	0/ 32	5/ 41	10/ 50	10/ 50	15/ 59	15/ 59	20/ 68	20/ 68	20/ 68	25/ 77	25/ 77	25/ 77	25/ 77	30/ 86	30/ 86	30/ 86	30/ 86	30/ 86	35/ 95
	40/ 104	0/ 32	5/ 41	10/ 50	10/ 50	15/ 59	20/ 68	20/ 68	20/ 68	25/ 77	25/ 77	25/ 77	30/ 86	30/ 86	30/ 86	35/ 95	35/ 95	35/ 95	35/ 95	35/ 95	40/ 104
	45/ 113	0/ 32	10/ 50	15/ 59	15/ 59	20/ 68	25/ 77	25/ 77	25/ 77	30/ 86	30/ 86	35/ 95	35/ 95	35/ 95	35/ 95	40/ 104	40/ 104	40/ 104	40/ 104	40/ 104	45/ 113
	50/ 122	5/ 41	10/ 50	15/ 59	20/ 68	25/ 77	25/ 77	30/ 86	30/ 86	35/ 95	35/ 95	35/ 95	40/ 104	40/ 104	40/ 104	45/ 113	45/ 113	45/ 113	45/ 113	45/ 113	50/ 122
	60/ 140	15/ 59	20/ 68	25/ 77	30/ 86	30/ 86	35/ 95	40/ 104	40/ 104	40/ 104	45/ 113	45/ 113	50/ 122	50/ 122	50/ 122	50/ 122	50/ 122	50/ 122	50/ 122	50/ 122	60/ 140
	70/ 158	20/ 68	25/ 77	35/ 95	35/ 95	40/ 104	45/ 113	45/ 113	50/ 122	50/ 122	50/ 122	50/ 122	50/ 122	60/ 140	60/ 140	60/ 140	60/ 140	60/ 140	60/ 140	60/ 140	70/ 158
	80/ 176	25/ 77	35/ 95	40/ 104	45/ 113	50/ 122	50/ 122	60/ 140	60/ 140	60/ 140	60/ 140	60/ 140	60/ 140	70/ 158	70/ 158	70/ 158	70/ 158	70/ 158	70/ 158	70/ 158	80/ 176
	90/ 194	35/ 95	40/ 104	50/ 122	50/ 122	50/ 122	60/ 140	60/ 140	60/ 140	70/ 158	70/ 158	70/ 158	70/ 158	80/ 176	80/ 176	80/ 176	80/ 176	80/ 176	80/ 176	80/ 176	90/ 194
	100/ 212	40/ 104	50/ 122	50/ 122	60/ 140	60/ 140	70/ 158	70/ 158	70/ 158	80/ 176	80/ 176	80/ 176	80/ 176	80/ 176	90/ 194	90/ 194	90/ 194	90/ 194	90/ 194	90/ 194	100/ 212

Tab. 2: Minimum device temperatures [°C/°F]



Example:

Ambient temperature = 50 °C
 Relative humidity = 40 %
 Minimum device temperature = 30 °C

Temperatures higher than 55°C (131°F) are not recommended due to the temperature limitation of the device.

The use of lower temperatures is at your own risk!

5.7 Air purge collar

The air purge system produces a laminar air flow that protects the linescanner window from dust, moisture, and vapor. The air flows from the couplings through the walls of the housing and through side slits near the scanner's window. The air flow should be between 100 l/min (3.53 cfm) and 200 l/min (7.06 cfm) through each side, which corresponds to a pressure between 0.5 bar (7.25 psig) and 3.0 bar (43 psig) when using the supplied metric fittings. The inside diameter for the air hose should be 4 mm (0.16 in.). The hose couplings for the air purge system are connected to the housing through ISO 228 G 1/8" stainless steel fittings.



Use only clean or "instrument grade" air (free from oil contaminants). Do not use cooled air. This could lead to condensation on the linescanners window!

5.8 Laser

The built-in laser sighting function allows fast and precise aiming at small or rapidly moving targets, or targets passing at irregular intervals. The laser is specially aligned with the scan line of the linescanner. A small, bright red laser line shows you the center of the scanned line, not the size of the spots being measured.

The laser can be turned on and off via the scanner runtime software, see menu <Scanner> <Switch Laser on/off>.



To preserve laser longevity, the laser automatically turns off after 10 minutes of constant use!

Technical Data:

Laser type	Laser diode
Wavelength	635 nm, red
Internal temperature	automatic switch off at < 5°C (41°F) or > 50°C (122 °F)
Output power	1 mW
Laser class	2
Horizontal angle	70°, non-symmetrically

WARNING!

**Avoid exposure to laser light! Eye damage can result. Use extreme caution when operating!
Never point at another person!**



Operation

6 Operation

6.1 Scan Rate and Target Viewing Time

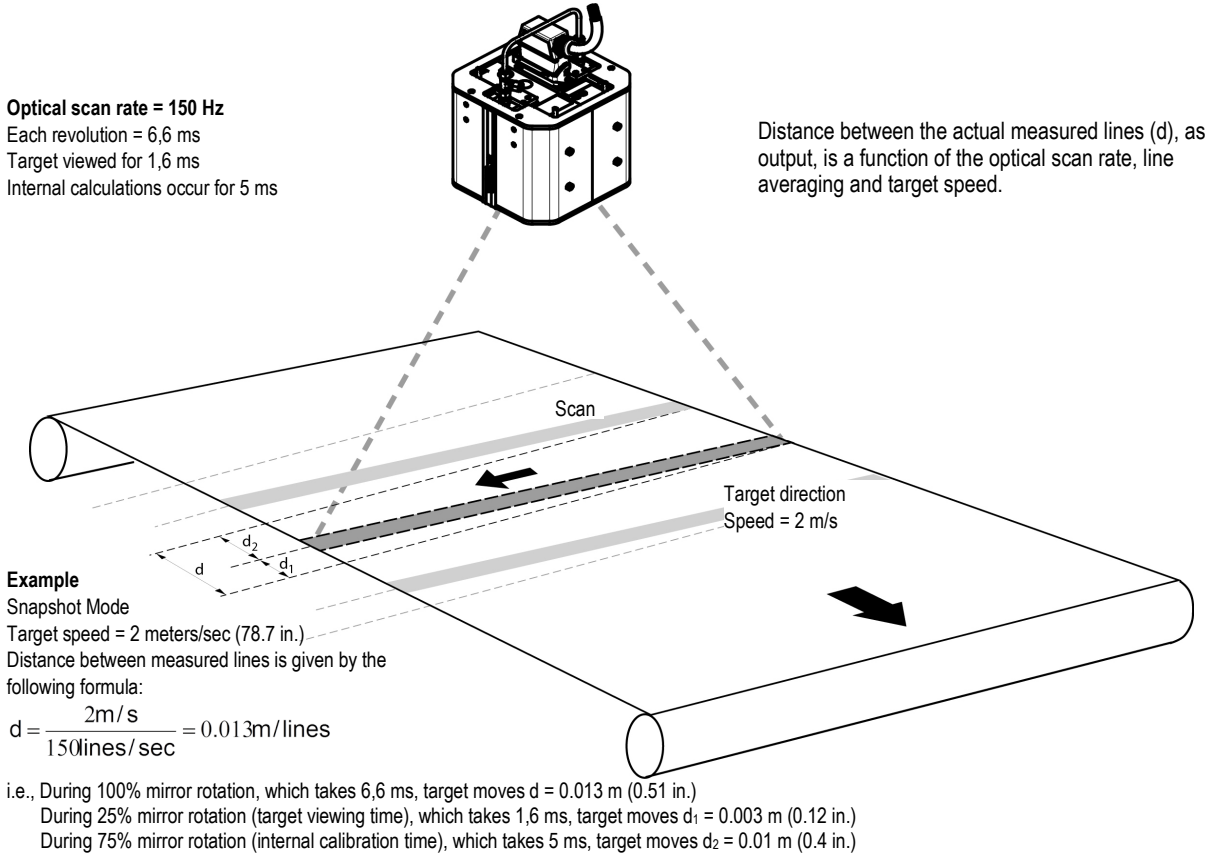

Figure 14: Linescanner applied to a moving target

6.2 Sectors

Via the processor box the linescanner is able to support multiple analog outputs. Each output can be assigned to a "sector" within the 90° scan angle. For each sector, the type of result (maximum, minimum, or mean value) can be selected. Each sector result can drive an alarm output in case of violating a given threshold.

The output range can be configured for either 0 ... 20 mA, 4 ... 20 mA, or custom configured by user settings. The sector size and the emissivity value can be set for each sector, even if the sectors overlap. (In the case of overlapping sectors, the higher emissivity is given priority.) To use the sector function, the linescanner must run in the continuous mode.



Use the Configurator of the scanner software to configure the analog outputs!

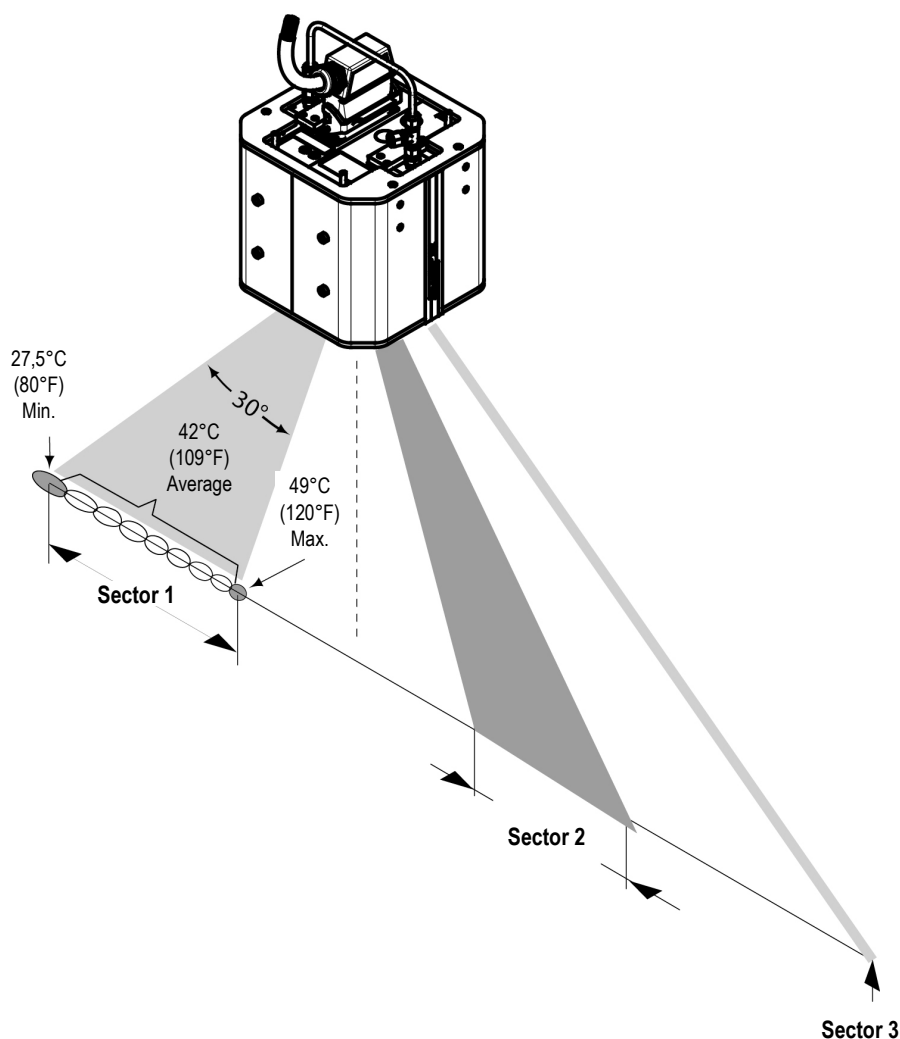

Figure 15: Monitoring of Sectors

Operation

- The maximum size of a sector is 90°.
- The corresponding analog output will remain inactive if the sector size is 0.
- Each sector can have either a maximum, minimum, or mean output value.
- Each sector is assigned to an analog interface.
- The output range can be adjusted to any value between 0-20mA.
- The analog interfaces are potential-free, but have a common ground connection

6.3 Data Transfer Modes

After each scan, the temperature values are transferred through the serial or the Ethernet interface to a computer. This computer will require either ScanView Pro software or custom software for data analysis. The data transfer can be achieved through one of two methods (selected by the user):

- **Snapshot mode (discontinuous mode):** The lines are scanned at the set sampling rate and are subsequently stored in the internal memory of the linescanner (capacity: 700 lines). After completing the snapshot, all lines are transferred through the digital interface. When measuring discrete objects, it may be advantageous to use the trigger input of the linescanner to initiate the image capture. The trigger signal can be generated by a voltage/switch indicating the approach of an object from the production process into the linescanner field-of-view.
- **Image mode (continuous mode):** One line is scanned and transferred through the digital interface immediately. The duration of the data transfer is determined by the maximum interface speed. These factors determine whether every line is transferred.

7 Accessories

7.1 Overview

A full range of accessories for various applications and industrial environments are available. Accessories include items that may be ordered at any time and added on-site. These include the following:

Mechanical:

- [Adjustable Mounting Base](#) (S3X-RMB)
- [Tube Fittings](#), ISO (S3X-FSISO) or NPT (S3X-FSNPT)
- [Spare Windows](#) (S3X-SWKxxx)
- [Replacement Kit for ScanIR2 Cooling Housing](#) (S3X-REPKIT)

Input/Output Modules:

- see the dedicated manual „I/O Module System for ScanIR3 Linescanner“

Communications:

- [Fiber Optic / RJ45 Ethernet Converter](#) (S3X-LWL)

Accessories

7.2 Adjustable Mounting Base

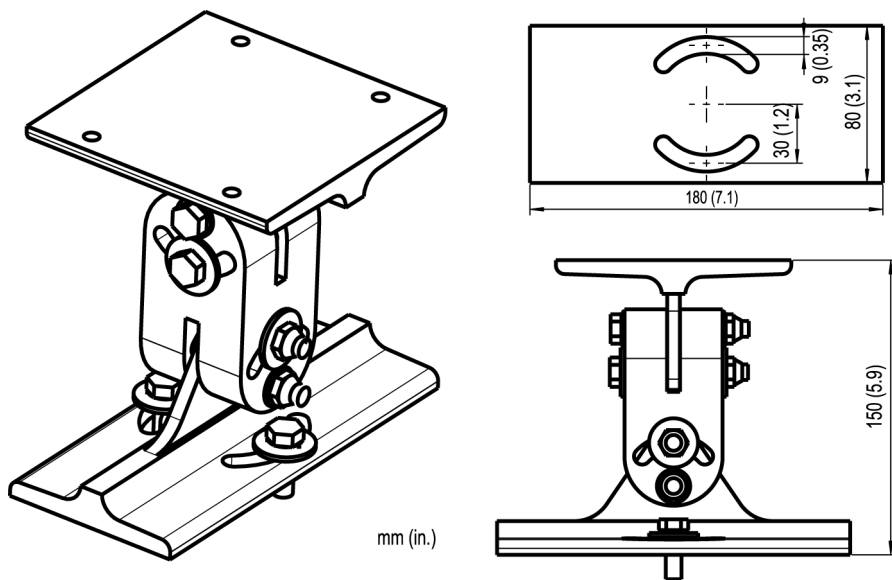

Figure 16: Adjustable Mounting Base (S3X-RMB)

7.3 Tube Fittings

Description: 4x tube fittings - female adapter union (connects 6 mm outer diameter tube to conical thread Rc 1/8" (ISO7/1)) or 6 mm outer diameter tube to conical thread 1/8" NPT

7.3.1 Installation of the Tube Fittings

The following steps explain the installation of the tube fittings to the stainless steel cooling tubes of the linescanner. ¹



- Insert tubing into the Swagelok tube fitting.
- Make sure that the tubing rests firmly on the shoulder of the tube fitting body and that the nut is finger-tight.

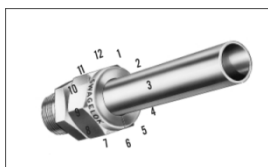

- Scribe the nut at the 6 o'clock position.

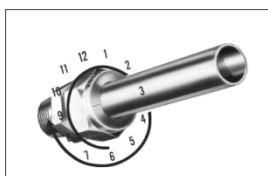

- While holding the fitting body steady with a back-up wrench, tighten the nut 1 ¼ turns to the 9 o'clock position.

7.3.2 Reassembly of the Tube Fittings

You may disassemble and reassemble a Swagelok tube fitting as often as required.



- Insert tubing with pre-swaged ferrules into the fitting body until the front ferrule seats.



- Rotate the nut with a wrench to the previously pulled-up position. At this point, a significant increase in resistance will be encountered.



- Tighten slightly with a wrench.

¹ Illustrations: © Swagelok

7.4 Spare Windows

The available spare windows are listed in the table below. Each spare window includes a gasket. For replacing the spare window see the procedure described in section 8.3 [Replacing the Window](#), page 48.

Spare Window	Spectral Model
S3X-SWK30	S330
S3X-SWK39	S339
S3X-SWK50	S350
S3X-SWK10	S310
S3X-SWK20	S320
S3X-SWK43	S34x

Tab. 3: Available Spare Windows depending on the Spectral Model

Each spare window comes with a dedicated factor for the transmissivity. The transmissivity needs to be set in the scanner via the scanner system software under the menu <Scanner> <Transmissivity of the scanner window> or by using the dedicated scanner command <TAW>.

7.5 Replacement Kit for ScanIR2 Cooling Housing

The S3X-REPKIT replacement kit is used to install a ScanIR3 Scanner in a legacy ScanIR2 Cooling Housing. To mount the scanner into the housing follow the steps given below.

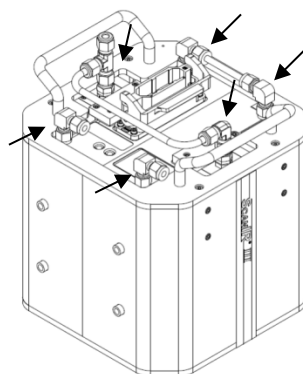

Mount the fittings on the scanner as shown in the figure.

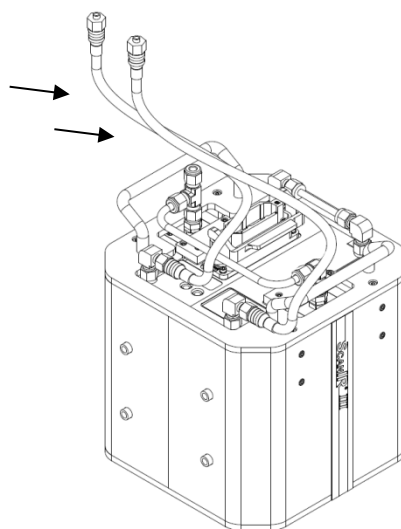

Assemble the two 18" stainless steel braided hoses.

Accessories

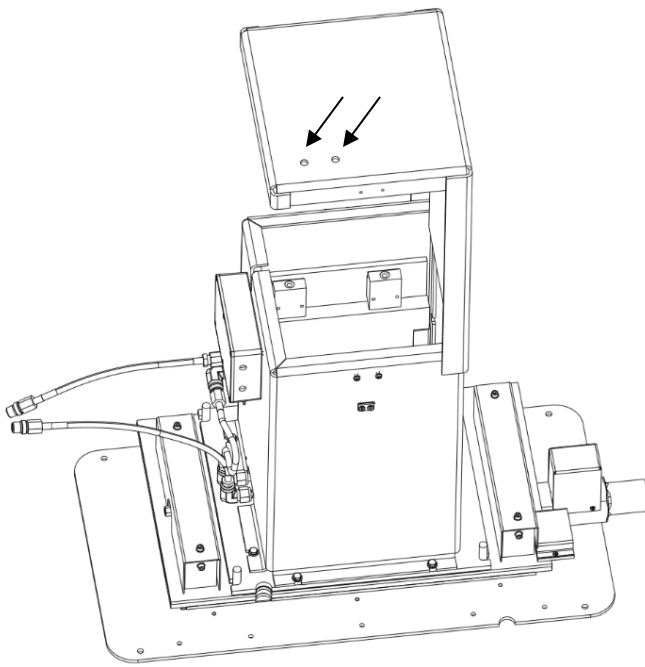

Drill two 11.5 mm (0.45 in) holes in the lid of the enclosure. The position of the holes can almost be chosen freely. Keep in mind to prevent collisions with other parts of the enclosure.

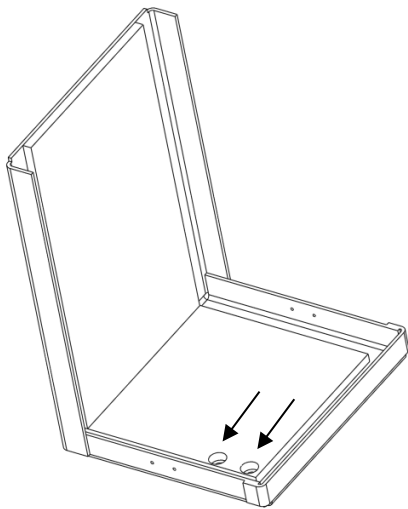

Depending on the used tool for mounting the shot-fittings, the refractory needs holes in a particular diameter as well. Cut two holes in the refractory. The positions have to match with the drills in the aluminum lid.

Assemble the bulkhead fittings in the lid.

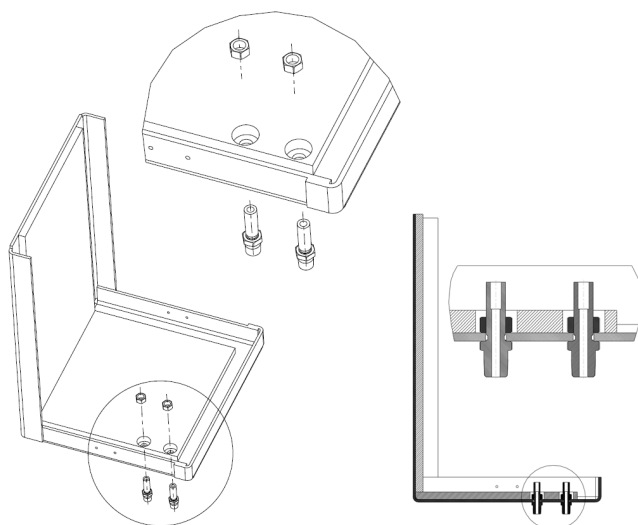

Retrieve the alignment poles and mount them in the enclosure.

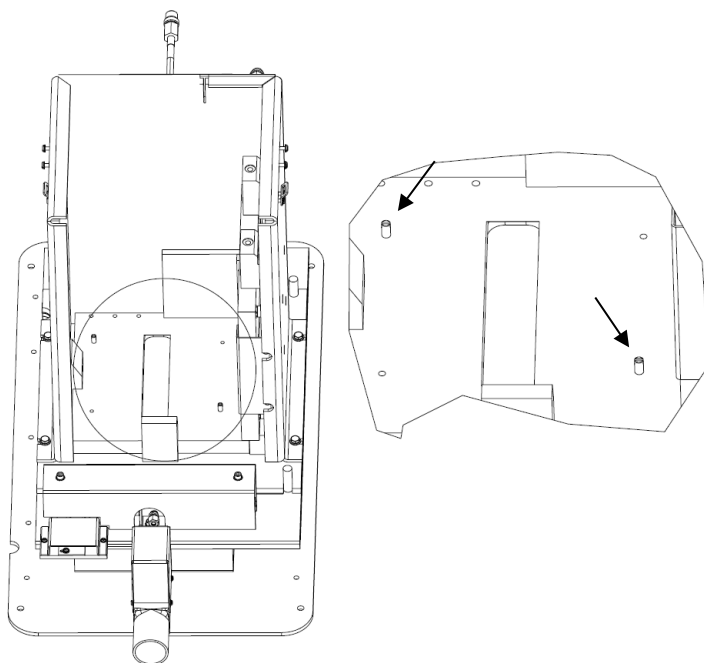

Accessories

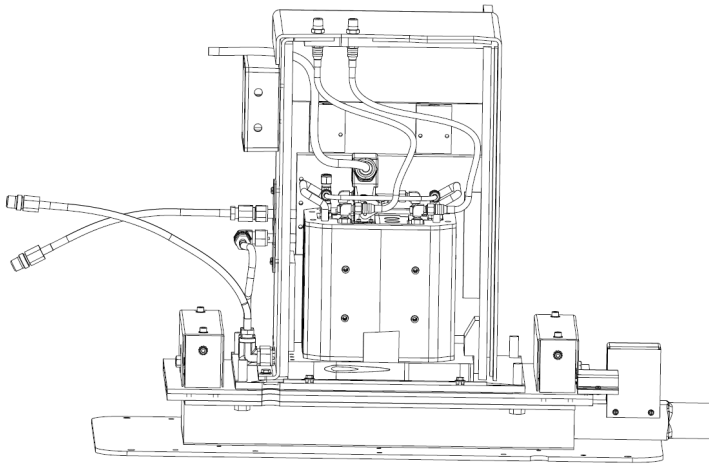

Place the scanner cable in the notch.
Put the scanner on the cooling plate
and align it with the alignment
poles.

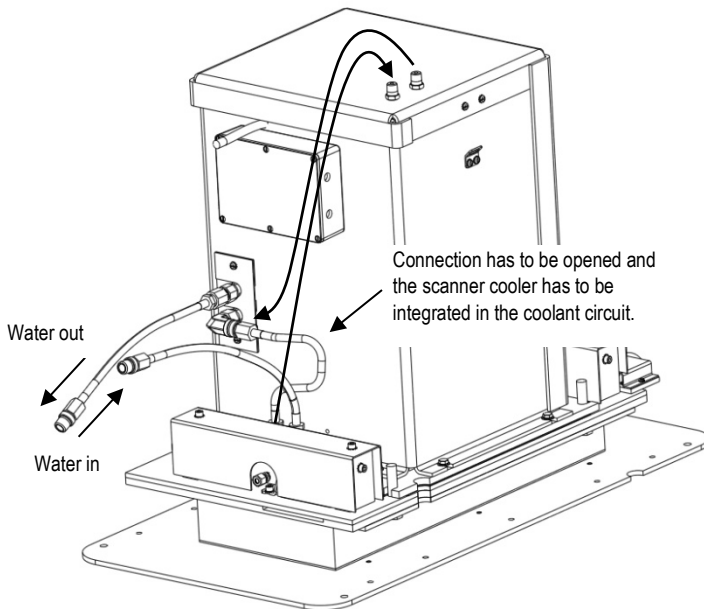

In order to integrate the internal
cooling system of the scanner to the
cooling system of the housing the
connection between both cooling
plates has to be opened. Attach two
hoses (not part of the delivery) to
the bulkhead fittings 1/4 inch male
NPT.

7.6 Fiber Optic / RJ45 Ethernet Converter

The Fiber Optic / RJ45 Ethernet Converter S3X-LWL (type Advantech EKI-2541M) assures high reliability and stability in harsh environments, making it a robust bridge between enterprise fiberoptic backbones and Ethernet devices, like the ScanIR3 linescanner. Using fiber optics, you prevent electrical interference from corrupting the linescanner system. The Fiber Optic / RJ45 Ethernet Converter supports fast speed and high distance transmissions. Copper-based Ethernet communication is limited in length without using a repeater.

A second Fiber Optic / RJ45 Ethernet Converter is required to reconvert the fiber optic signals back to TCP/IP Ethernet again.



Ethernet Communications

Ports	1x
Port connector	RJ45
Distance	max. 90 m (295 ft)

Fiber Optic Communications

Ports	1x
Port connector	SC type
Fiber	multi-mode, 62.5/125 μm or 50/125 μm
Distance	max. 2 km (1.24 mi)

Mechanics

Dimensions (W x H x D)	37 x 140 x 95 mm (1.45 x 5.5 x 3.7 in)
Mounting	DIN-rail, wall

Power

Power input	12 to 48 VDC, redundant dual inputs
Power connector	removable screw terminal
Power consumption	2.7 W

Environment

Operating temperature	-10 to 60°C (14 to 140°F)
Storage temperature	-40 to 85°C (-40 to 185°F)
Operating humidity	5 to 95% RH
Protection	4 kV _{DC} ESD (Ethernet), 3 kV _{DC} Surge (EFT for power)

Maintenance

8 Maintenance

If you need application assistance, calibration, repair, and solutions to specific problems our customer service representatives are always at your disposal. In many cases, problems can be solved over the telephone. If you need to return equipment to us, please contact our Service Department before doing so, please look at the address page for contact information.

8.1 Removing the Adapter Housing

Remove the four M4x8 screws like shown in the figure.

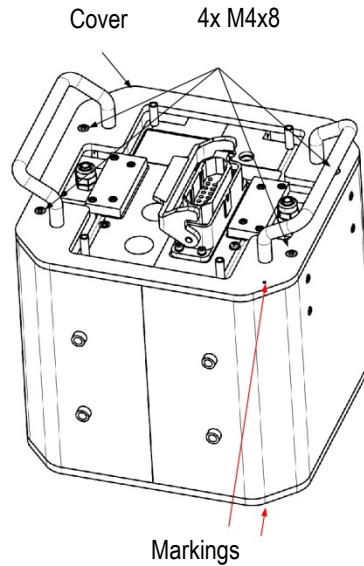

Figure 17: Removing the Adapter Housing

Turn the scanner up side down and detach the four M6x10 screws.

4x M6x10

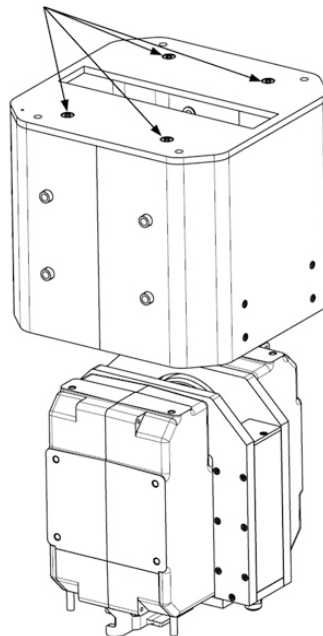

Figure 18: Removing the Adapter Housing

Maintenance

8.2 Cleaning the Window

The linescanner's window must be kept as clean as possible. Any foreign matter on the window will affect the accuracy of the measurements. Take care when cleaning the window as it can easily be scratched. Please observe the following guidelines:

- Lightly blow off loose particles.
- Gently brush off remaining particles with a soft camel hair brush.
- Clean remaining dirt using a soft cotton cloth dampened in distilled water. Don't rub.
- To remove finger prints or other grease, gently wipe with a soft cloth dampened in a mild soap or distilled water (or ethanol or alcohol) solution.
- You should avoid getting any liquid in areas surrounding the window material.

8.3 Replacing the Window

1. Remove the surrounding enclosure, see section 8.1 [Removing the Adapter Housing](#), page 47.
2. Remove the 4 hex screws on the back side using a 2.5 mm allen wrench. Slide the collar forward to separate it from the housing!

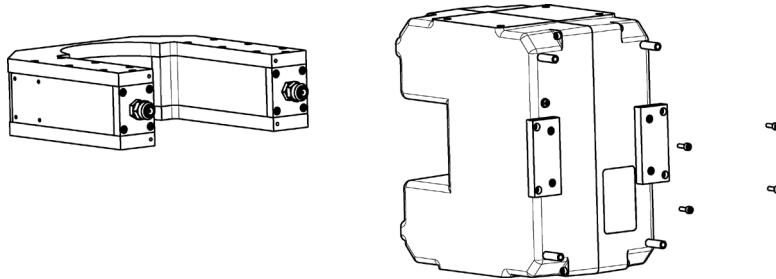

Figure 19: Removing the air purge collar

3. Remove the 4 hex screws on the front side separating the window frame from the housing. Separate the window from the frame!
4. The window assembly consists of a frame (holder), the window material (mica) and a gasket. The gasket lies close to the housing, followed by the window material. If necessary, exchange the window material. Window size: 114 x 60 mm (4.49 x 2.36 inches).

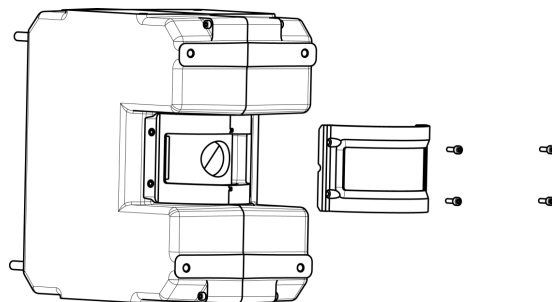

Figure 20: Separating the window

5. The four mounting screws must be placed in the holder's corners before reassembling! Center the new film on the housing's gasket!
6. Check for even tension of the film. Remove the film and repeat the steps if there are wrinkles on the film!

7. Install the window assembly on the housing by alternating between the four screws. Do not over-tighten!
8. Install the air purge collar on the housing!



For correct temperature readings, the transmission factor for the new window must be set via the scanner runtime software, see menu <Scanner> <Transmissivity of the scanner window>!

Troubleshooting

9 Troubleshooting

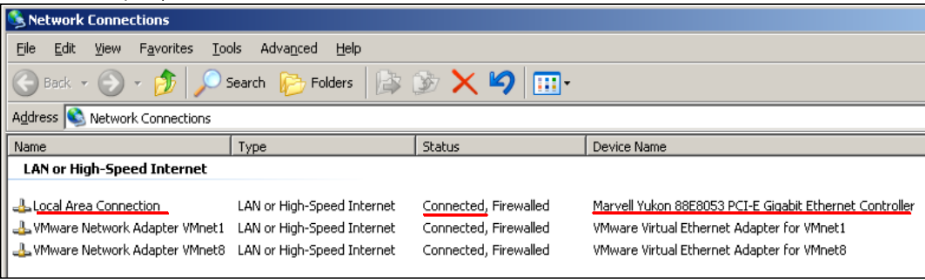
Checkpoint	Possible Cause / Solution																				
Scanner	<ul style="list-style-type: none"> • Check the wiring of the whole system (correctly fitted connectors, cable damage). • Check the power for the scanner on scanner's backside LED: green LED is "on" • Check the rotation of the internal scanner mirror assuming the power is on (viewing or hearing test). • The main power for processor box and PC should be provided at the same location. • Avoiding scanner overheating. Maximum internal housing temperature: 60°C (140°F). The internal housing temperature is displayed in the status bar of the scanner software. • In case of the scanner's cooling, check for condensation in the scanner's housing → condensation can cause the total outage of the unit. To avoid condensation see section 5.6.1 Avoiding Condensation, page 31. • Mount the scanner and the cables away from motors or heaters that produce strong electrical fields. • A dirty measurement window or an obstructed field of view could cause erroneous temperature values 																				
Ethernet Communication	<ul style="list-style-type: none"> • Make sure that the scanner's Ethernet settings are setup correctly, see section 5.4.1 Ethernet Settings, page 27. • Make sure that the PC network adapter is setup correctly, see section 5.4.2 Changing the Ethernet Settings for the PC, page 28. • <Start> <Settings> <Network Connections> provides a list of all available network connections. The desired network connection needs to be related to your real adapter device (and no wireless or virtual adapter). The status for the connection needs to be <Connected>.  <table border="1" data-bbox="389 1263 1318 1541"> <thead> <tr> <th>Name</th> <th>Type</th> <th>Status</th> <th>Device Name</th> </tr> </thead> <tbody> <tr> <td colspan="4">LAN or High-Speed Internet</td> </tr> <tr> <td>Local Area Connection</td> <td>LAN or High-Speed Internet</td> <td>Connected, Firewallled</td> <td>Marvell Yukon 88E8053 PCI-E Gigabit Ethernet Controller</td> </tr> <tr> <td>VMware Network Adapter VMnet1</td> <td>LAN or High-Speed Internet</td> <td>Connected, Firewallled</td> <td>VMware Virtual Ethernet Adapter for VMnet1</td> </tr> <tr> <td>VMware Network Adapter VMnet8</td> <td>LAN or High-Speed Internet</td> <td>Connected, Firewallled</td> <td>VMware Virtual Ethernet Adapter for VMnet8</td> </tr> </tbody> </table> <ul style="list-style-type: none"> • Disable the PC network adapter temporarily: <Start> <Settings> <Control panel> <System> <Hardware> <Device Manager> <Network adapters> 	Name	Type	Status	Device Name	LAN or High-Speed Internet				Local Area Connection	LAN or High-Speed Internet	Connected, Firewallled	Marvell Yukon 88E8053 PCI-E Gigabit Ethernet Controller	VMware Network Adapter VMnet1	LAN or High-Speed Internet	Connected, Firewallled	VMware Virtual Ethernet Adapter for VMnet1	VMware Network Adapter VMnet8	LAN or High-Speed Internet	Connected, Firewallled	VMware Virtual Ethernet Adapter for VMnet8
Name	Type	Status	Device Name																		
LAN or High-Speed Internet																					
Local Area Connection	LAN or High-Speed Internet	Connected, Firewallled	Marvell Yukon 88E8053 PCI-E Gigabit Ethernet Controller																		
VMware Network Adapter VMnet1	LAN or High-Speed Internet	Connected, Firewallled	VMware Virtual Ethernet Adapter for VMnet1																		
VMware Network Adapter VMnet8	LAN or High-Speed Internet	Connected, Firewallled	VMware Virtual Ethernet Adapter for VMnet8																		

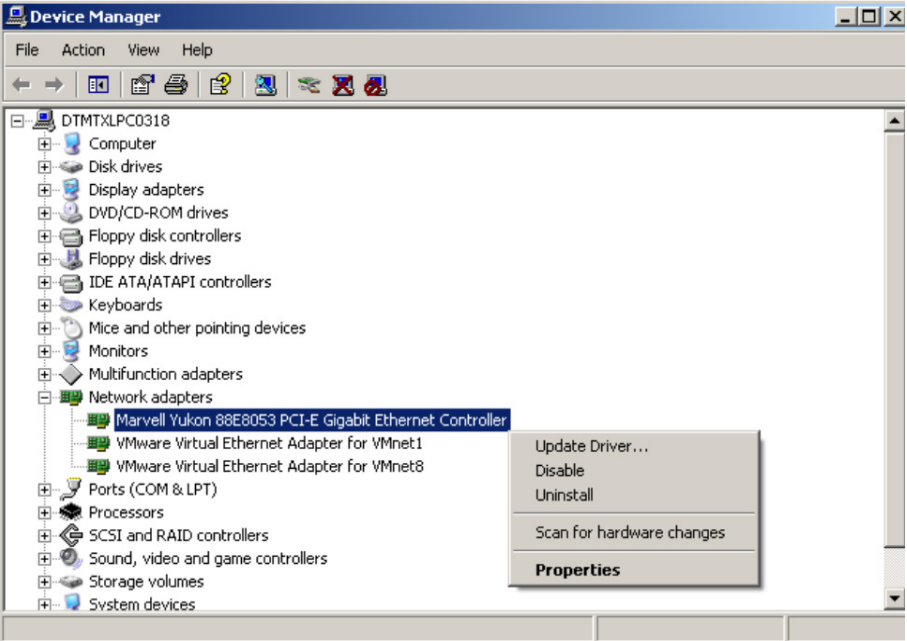
Checkpoint	Possible Cause / Solution
	 <ul style="list-style-type: none"> • Switch on/off the scanner's power. • Software is not to be launched during the initialization time of the scanner (about 30 s). • Use the network administration utility Ping to test the reachability of the scanner. Call the Windows <Command Prompt> and execute ping 192.168.42.30 (exemplary IP address) • Use the network protocol Telnet to provide a bidirectional text-oriented communication to the scanner by using the scanner specific commands. Call the Windows <Command Prompt> and execute telnet 192.168.42.30 2727 (exemplary IP address and port). Note: Telnet is not available on all Windows computers by default!
<p>PC</p>	<ul style="list-style-type: none"> • On some computers, the performance of the software can be increased dramatically by switching off the hardware graphic acceleration: <Start> <Settings> <Control Panel> <Display> <Settings> <Advanced> <Troubleshooting> <Hardware acceleration>: None • A too high display resolution can cause problems. Test temporarily a setting of 800x600 pixel at high color (16 bit). • For several reasons the PC can be overloaded. This can be checked by running the scanner software and pushing CTRL+ALT+DEL at the same time. In the task manager a window for the system performance can be selected. The value must be every time much below 100%. • In some cases, the graphic card of the computer can interrupt serial communications for too long a time. S3-graphic cards are known to exhibit this problem. The only solution is to exchange the S3-graphic card.

Appendix

10 Appendix

10.1 Determination of Emissivity

Emissivity is a measure of an object's ability to absorb and emit infrared energy. It can have a value between 0 and 1.0. For example a mirror has an emissivity less of 0.1, while the so-called "Blackbody" reaches an emissivity value of 1.0. If a higher than actual emissivity value is set, the output will read low, provided the target temperature is above its ambient temperature. For example, if you have set 0.95 and the actual emissivity is 0.9, the temperature reading will be lower than the true temperature. An object's emissivity can be determined by one of the following methods:

1. Determine the actual temperature of the material using an RTD (PT100), a thermocouple, or any other suitable method. Next, measure the object's temperature and adjust emissivity setting until the correct temperature value is reached. This is the correct emissivity for the measured material.
2. For relatively low temperatures (up to 260°C, 500°F) place a plastic sticker on the object to be measured. This sticker should be large enough to cover the target spot. Next, measure the sticker's temperature using an emissivity setting of 0.95. Finally, measure the temperature of an adjacent area on the object and adjust the emissivity setting until the same temperature is reached. This is the correct emissivity for the measured material.
3. If possible, apply flat black paint to a portion of the surface of the object. The emissivity of the paint must be above 0.95. Next, measure the temperature of the painted area using an emissivity setting of 0.95. Finally, measure the temperature of an adjacent area on the object and adjust the emissivity until the same temperature is reached. This is the correct emissivity for the measured material.

10.2 Typical Emissivity Values

The following table provides a brief reference guide for determining emissivity and can be used when one of the above methods is not practical. Emissivity values shown in the table are only approximate, since several parameters may affect the emissivity of a material. These include the following:

1. Temperature
2. Angle of measurement
3. Geometry (plane, concave, convex)
4. Thickness
5. Surface quality (polished, rough, oxidized, sandblasted)
6. Spectral range of measurement
7. Transmissivity (e.g. thin films plastics)

Material	METALS			
	Emissivity			
	1 μm	1.6 μm	3.9 μm	5 μm
Aluminum				
Unoxidized	0.1-0.2	0.02-0.2	0.02-0.2	0.02-0.2
• Oxidized	0.4	0.4	0.2-0.4	0.2-0.4
Alloy A3003, Oxidized		0.4	0.4	0.4
Roughened	0.2-0.8	0.2-0.6	0.1-0.4	0.1-0.4
Polished	0.1-0.2	0.02-0.1	0.02-0.1	0.02-0.1
Brass				
Polished	0.35	0.01-0.05	0.01-0.05	0.01-0.05
Burnished	0.65		0.3	0.3
Oxidized		0.6	0.5	0.5
Chromium	0.4	0.4	0.03-0.3	0.03-0.3
Copper				
Polished	0.05	0.03	0.03	0.03
Roughened	0.05-0.2	0.05-0.2	0.05-0.15	0.05-0.15
Oxidized	0.2-0.8	0.2-0.9	0.5-0.8	0.5-0.8
Gold	0.3	0.01-0.1	0.01-0.1	0.01-0.1
Haynes				
Alloy	0.5-0.9	0.6-0.9	0.3-0.8	0.3-0.8
Inconel				
Oxidized	0.4-0.9	0.6-0.9	0.6-0.9	0.6-0.9
Sandblasted	0.3-0.4	0.3-0.6	0.3-0.6	0.3-0.6
Electropolished	0.2-0.5	0.25	0.15	0.15
Iron				
Oxidized	0.7-0.9	0.5-0.8	0.6-0.9	0.6-0.9
Unoxidized	0.35	0.1-0.3	0.05-0.25	0.05-0.25
Rusted		0.6-0.9	0.5-0.8	0.5-0.8
Molten	0.35	0.4-0.6	—	—
Iron, Cast				
Oxidized	0.9	0.7-0.9	0.65-0.95	0.65-0.95
Unoxidized	0.35	0.3	0.25	0.25
Molten	0.35	0.3-0.4	0.2-0.3	0.2-0.3
Iron, Wrought				
Dull		0.9	0.9	0.9

Tab. 4: Typical Emissivity Values

Appendix

Material	METALS			
	Emissivity			
	1 μm	1.6 μm	3.9 μm	5 μm
Lead				
Polished		0.05-0.2	0.05-0.2	0.05-0.2
Rough		0.6	0.4	0.4
Oxidized		0.3-0.7	0.2-0.7	0.2-0.7
Magnesium	0.3-0.8	0.05-0.3	0.03-0.15	0.03-0.15
Mercury		0.05-0.15	0.05-0.15	0.05-0.15
Molybdenum				
Oxidized	0.5-0.9	0.4-0.9	0.3-0.7	0.3-0.7
Unoxidized	0.25-0.35	0.1-0.35	0.1-0.15	0.1-0.15
Monel (Ni-Cu)	0.3	0.2-0.6	0.1-0.5	0.1-0.5
Nickel				
Oxidized	0.8-0.9	0.4-0.7	0.3-0.6	0.3-0.6
Electrolytic	0.2-0.4	0.1-0.3	0.1-0.15	0.1-0.15
Platinum				
Black		0.95	0.9	0.9
Silver	0.04	0.02	0.02	0.02
Steel				
Cold-Rolled	0.8-0.9	0.8-0.9	0.8-0.9	0.8-0.9
Ground Sheet			0.5-0.7	0.5-0.7
Polished Sheet	0.35	0.25	0.1	0.1
Molten	0.35	0.25-0.4	0.1-0.2	0.1-0.2
Oxidized	0.8-0.9	0.8-0.9	0.7-0.9	0.7-0.9
Stainless	0.35	0.2-0.9	0.15-0.8	0.15-0.8
Tin (Unoxidized)	0.25	0.1-0.3	0.05	0.05
Titanium				
Polished	0.5-0.75	0.3-0.5	0.1-0.3	0.1-0.3
Oxidized		0.6-0.8	0.5-0.7	0.5-0.7
Tungsten			0.05-0.5	0.05-0.5
Polished		0.1-0.3	0.05-0.25	0.05-0.25
Zinc				
Oxidized	0.6	0.15	0.1	0.1
Polished	0.5	0.05	0.03	0.03

Tab. 5: Typical Emissivity Values

Material	NON-METALS		
	Emissivity		
	1 μm	1.6 μm	5 μm
Asbestos	0.9	0.8	0.9
Asphalt			0.95
Basalt			0.7
Carbon		0.9	
Unoxidized			0.8-0.9
Graphite			0.7-0.9
Carborundum			0.9
Ceramic	0.4		0.8-0.95
Clay			0.85-0.95
Concrete	0.65	0.2	0.9
Cloth		0.4-0.9	0.95
Glass			
Plate			0.98
"Gob"			0.9
Gravel		0.95	0.95
Gypsum		0.8-0.95	0.4-0.97
Ice			—
Limestone			0.4-0.98
Paint (non-al.)		0.8-0.9	—
Paper (any color)		0.8-0.9	0.95
Plastic (opaque, over 20 mils)			0.95
Rubber			0.9
Sand			0.9
Snow			—
Soil			—
Water		0.8-0.95	—
Wood, Natural			0.9-0.95

Tab. 6: Typical Emissivity Values

To optimize surface temperature measurements, consider the following guidelines:

- Determine the object emissivity using the instrument which is also to be used for the measurements.
- Avoid reflections by shielding the object from surrounding temperature sources.
- For higher temperature objects use instruments with the shortest wavelength possible.
- For translucent materials such as plastic foils or glass, assure that the background is uniform and lower in temperature than the object.
- Mount the sensor perpendicular to surface whenever emissivity is less than 0.9. In all cases, do not exceed angles more than 30 degrees from incidence.