

O₂ SENSORS – Zirconium Dioxide (ZrO₂)

OXY-LC Interface Board User's Guide

This document describes the installation, operation and maintenance of the OXY-LC interface board.

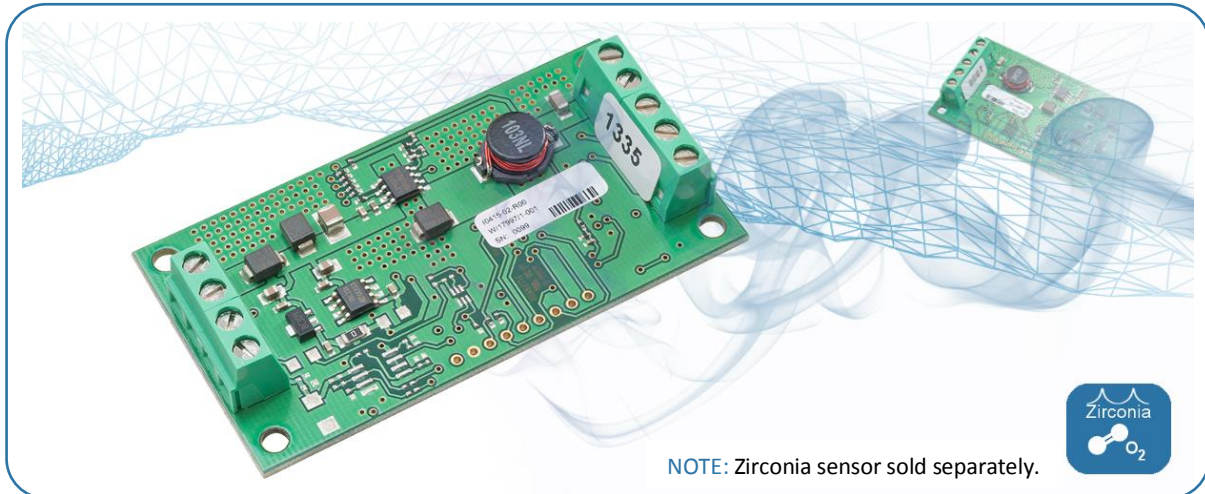

The OXY-LC Interface Board provides the electronics necessary to power and control SST's range of zirconium dioxide (ZrO₂) sensors.

The interface board has a built-in pressure sensor for barometric pressure compensation.

Contents

| | | |
|-----|--|------|
| 1 | DEFINITIONS..... | 1-1 |
| 2 | SAFETY INSTRUCTIONS..... | 2-1 |
| 3 | TECHNICAL SPECIFICATIONS | 3-1 |
| 4 | PRODUCT OVERVIEW..... | 4-1 |
| 4.1 | Components | 4-1 |
| 4.2 | External Dimensions..... | 4-1 |
| 5 | INSTALLATION | 5-1 |
| 5.1 | Installation Procedure | 5-1 |
| 5.2 | Mounting Instructions..... | 5-2 |
| 5.3 | Electrical Connections | 5-3 |
| 6 | INITIAL STARTUP..... | 6-1 |
| 6.1 | Commissioning Checks..... | 6-1 |
| 6.2 | Switching ON | 6-1 |
| 6.3 | First-time Calibration | 6-1 |
| 7 | SYSTEM CONFIGURATION | 7-1 |
| 7.1 | Digital Output – RS485 Modbus Variant | 7-1 |
| 7.2 | Analogue Output – 0-10V _{DC} and 4-20mA Variants..... | 7-5 |
| 8 | OPERATION | 8-1 |
| 8.1 | General Operation | 8-1 |
| 8.2 | Operating Tips..... | 8-1 |
| 9 | MAINTENANCE | 9-1 |
| 9.1 | Cleaning..... | 9-1 |
| 9.2 | Calibrating..... | 9-1 |
| 9.3 | Diagnostic Routine | 9-3 |
| 9.4 | Error Conditions..... | 9-4 |
| 9.5 | Shutdown Procedure..... | 9-10 |
| 9.6 | Disposal | 9-10 |

1 DEFINITIONS

The following definitions apply to WARNINGS, CAUTIONS and NOTES used throughout this manual.



WARNING:

The warning symbol is used to indicate instructions that, if they are not followed, can result in minor, serious or even fatal injuries to personnel.



CAUTION:

The caution symbol is used to indicate instructions that, if they are not followed, can result in damage to the equipment (hardware and/or software), or a system failure occurring.

NOTE: Highlights an essential operating procedure, condition or statement.

2 SAFETY INSTRUCTIONS

- This equipment may only be installed by a suitably qualified technician in accordance with the instructions in this manual and any applicable standards associated with the country or industry.
- Failure to correctly adhere to these instructions may result in serious injury or death and in this regard the manufacturer will not be held liable.
- This equipment may only be operated and maintained by trained technical personnel. The technical personnel must strictly adhere to the instructions given in this manual, and any prevailing standards/certificates (depending on application).
- Where instructed, you must read the User Guides and Datasheets referenced within this manual. There, you can find detailed information on the equipment.
- The operator may only perform modifications and repairs to the equipment/system with written approval of the manufacturer.
- Do NOT operate damaged equipment.
- If faults cannot be rectified, the equipment must be taken out of service and secured against unintentional commissioning.

3 TECHNICAL SPECIFICATIONS

Electrical Specifications

- Supply voltage;
 - RS485 variant; 8 – 28V_{DC}
 - Analogue variants; 20 – 28V_{DC}
- Current consumption^a;
 - 600mA maximum at 24V_{DC}
 - 1.2A maximum at 12V_{DC}

Output Options^b

- Digital variant – one output; RS485 (Modbus RTU)
- Analogue variants – one output;
 - 0–10V; load 10kΩ maximum
 - 4 – 20mA; load 500Ω maximum
- Diagnostic output; PWM

Output / Sensor Specifications

- Measurement range;
 - RS485 variant; 0.1–100% O₂
 - Analogue variants^c; 0.1–25% O₂ or 0.1–100% O₂
- Accuracy after calibration; 0.5% O₂
- Repeatability after calibration; 0.5% O₂
- Resolution; 0.01% O₂
- Response time (step 10 – 90%);
 - Fast response sensor connected; 4s
 - Standard response sensor connected; 15s
- Initial warm up time (till stable output); 5–10mins
- Output inactive start up delay (heater warmup);
 - From OFF to ON mode; 60s
 - From Standby to ON mode (RS485 variant only); 20s

Environmental Specifications

- Operating temperature; -30 to +70°C
- Storage temperature; -40 to +85°C
- Operating pressure limits; 260 to 1260mbar absolute

Mechanical Specifications

- Connections; screw terminals, refer to [4.1 Components on page 4-1](#).
- Dimensions; refer to [4.2 External Dimensions on page 4-1](#).

^a Varies with supply voltage.

^b OXY-LC supports one digital output or one analogue output. PWM diagnostic output included with analogue variant if no digital output is selected.

^c Select at time of ordering.

4 PRODUCT OVERVIEW

The OXY-LC interface board provides the electronics necessary to power and control SST's range of zirconium dioxide (ZrO₂) sensors.

NOTE: Sensors are sold separately; refer to datasheets listed in [REFERENCE DOCUMENTS](#) for details.

4.1 Components

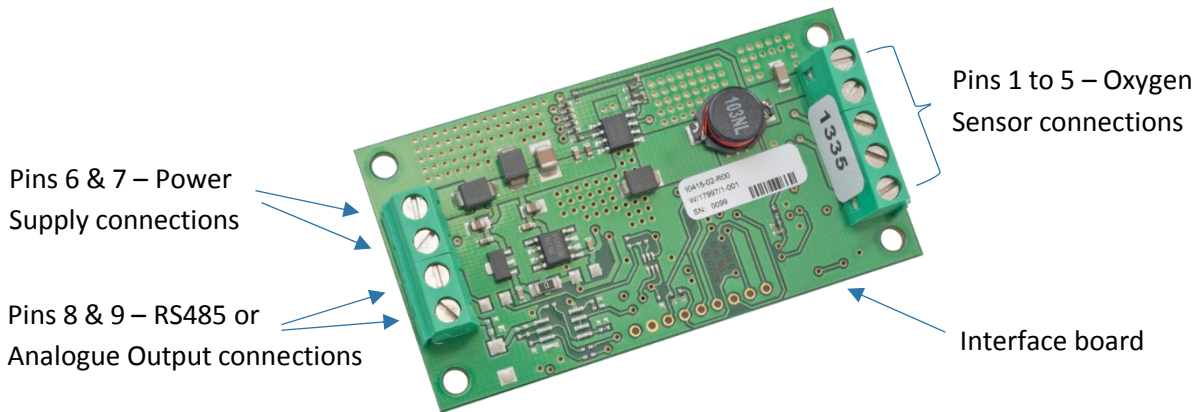

4.2 External Dimensions

Dimensions in mm unless otherwise stated; tolerance ± 0.5 mm.

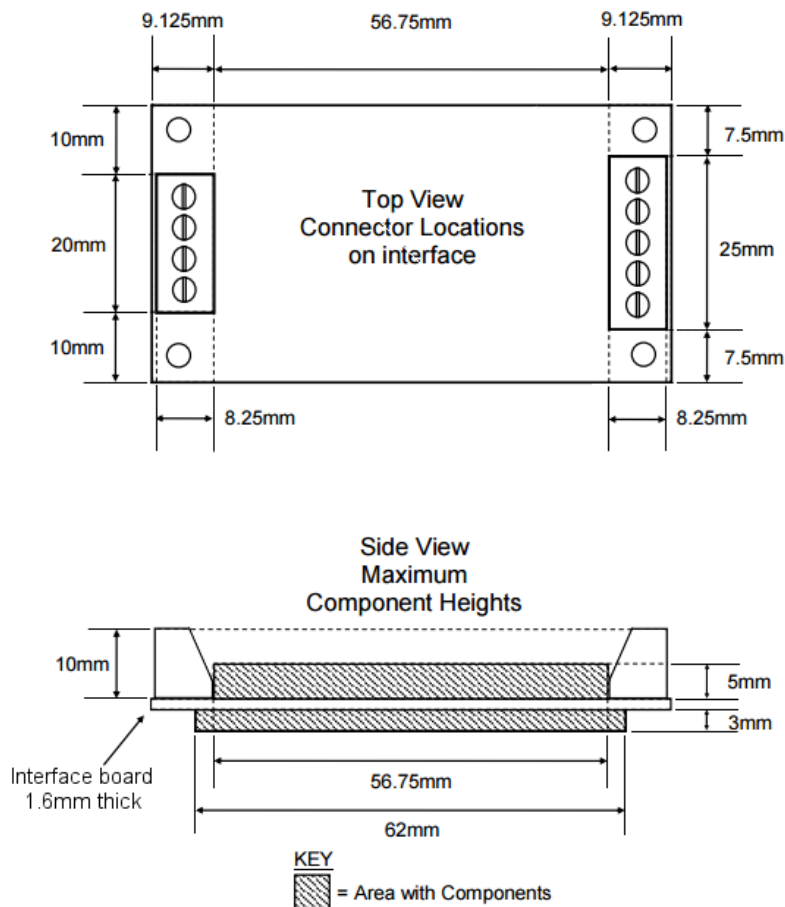

Figure 4-1 - OXY-LC Dimensions

5 INSTALLATION

To ensure the best performance from your equipment, it must be installed correctly.



Always handle the interface board using the correct ESD handling precautions.

NOTE: SST recommend housing the interface board in a suitable enclosure to protect from damage.

5.1 Installation Procedure

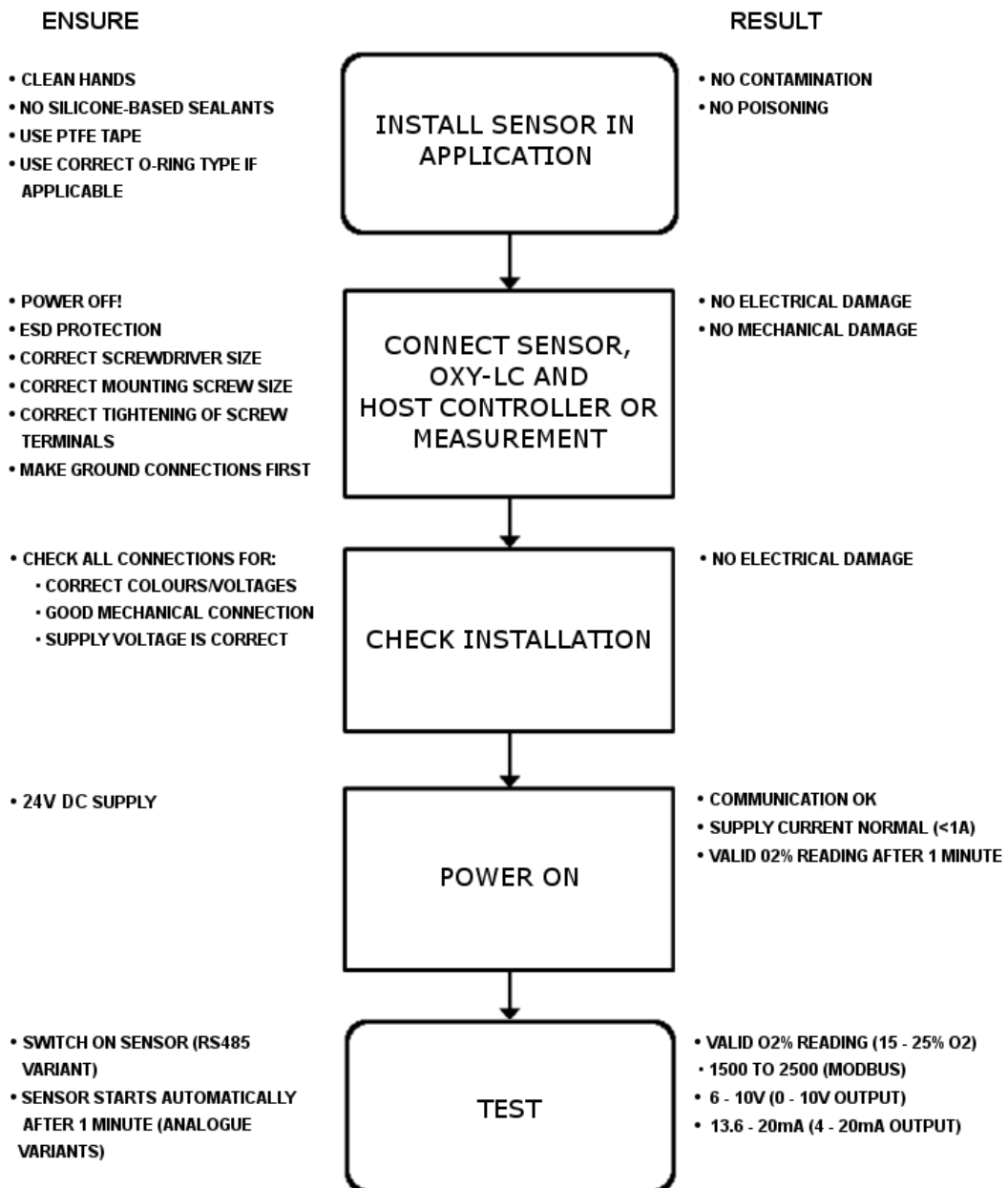

5.2 Mounting Instructions

Dimensions in mm unless otherwise stated; tolerance $\pm 0.5\text{mm}$.

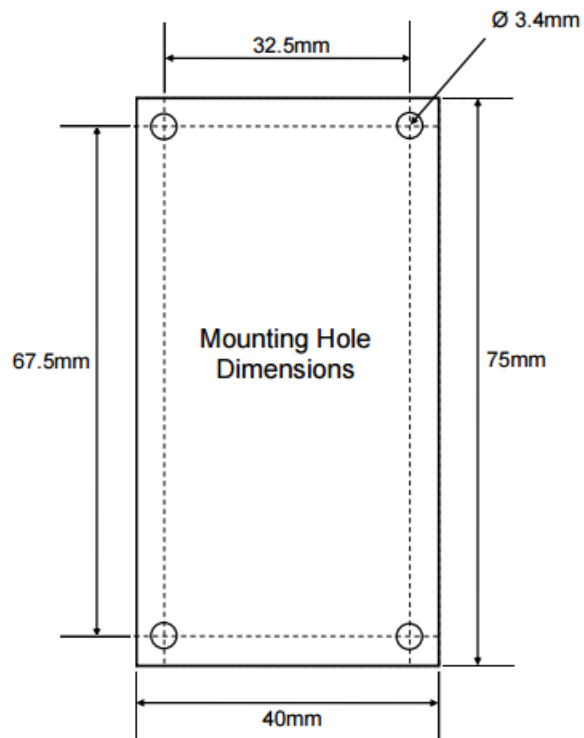

Figure 5-1 – Mounting Hole Positions

NOTE: The interface board must be securely fitted to a suitable mounting surface using the mounting holes provided; refer to [Figure 5-1](#).



CAUTION: Protect the device from accidental shocks or vibrations as this may damage the board.

5.3 Electrical Connections



WARNINGS:

All wiring **MUST** be in accordance with the National Electrical Code and any local codes, ordinances, and regulations.

Disconnect and lock out power before connecting the equipment to the power supply.

The device wiring should be in a separate conduit. Do **NOT** install wiring in any conduit or junction boxes with high voltage wiring.



CAUTION:

- Do **NOT** install the device suspended from the cable.
- Do **NOT** twist the cable(s).
- Avoid exerting excessive tensile force on the cable (e.g. tugging).



Always handle the interface board using the correct ESD handling precautions.

5.3.1 RS485 Variant

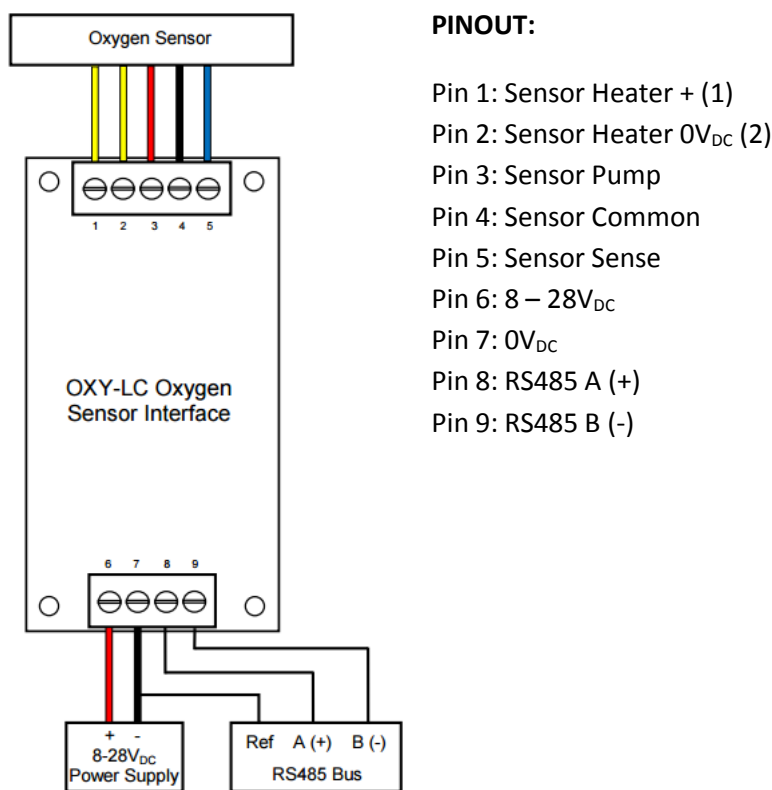

Figure 5-2 - RS485 Electrical Connections

NOTES:

- RS485 A and B (pins 8 and 9) are a half-duplex system and are referenced to the power supply $0V_{DC}$ (pin 7). A connection should be made between pin 7 and the reference or common connection of the RS485 Bus.
- Care should be taken when connecting the RS485 A and B connections to your system. The TIA-485 signaling specification states that signal A is the inverting or '1' pin and signal B is the

non-inverting or '+' pin. This is in conflict with the A and B naming used by a number of differential transceiver manufacturers, including the transceiver used in the interface board. Therefore, always ensure the '+' of the interface board is connected to the '+' input of the RS485 Bus and the '-' of the interface board connected to the '-' input of the RS485 Bus.

- The default communications settings can be amended to suit the application by connecting to the interface using the default settings then amending the Modbus registers associated with the communications as outlined on [page 7-1](#) and Modbus [Note 5](#) on [page 7-4](#).
- Output pins 1 through 5, refer to appropriate SST oxygen sensor datasheet for wiring/pin designations; refer to [REFERENCE DOCUMENTS](#) for datasheet details.
- All SST oxygen sensors have two heater connections which should be connected to pins 1 & 2 of the interface board; the heater coil has no polarity. However, when connecting to a sensor where the sensor housing is one of the heater connections (e.g. flange mounted, O2S-FR-T4 Range) pin 2 of the interface board should be connected to the housing.

5.3.2 Analogue Variants

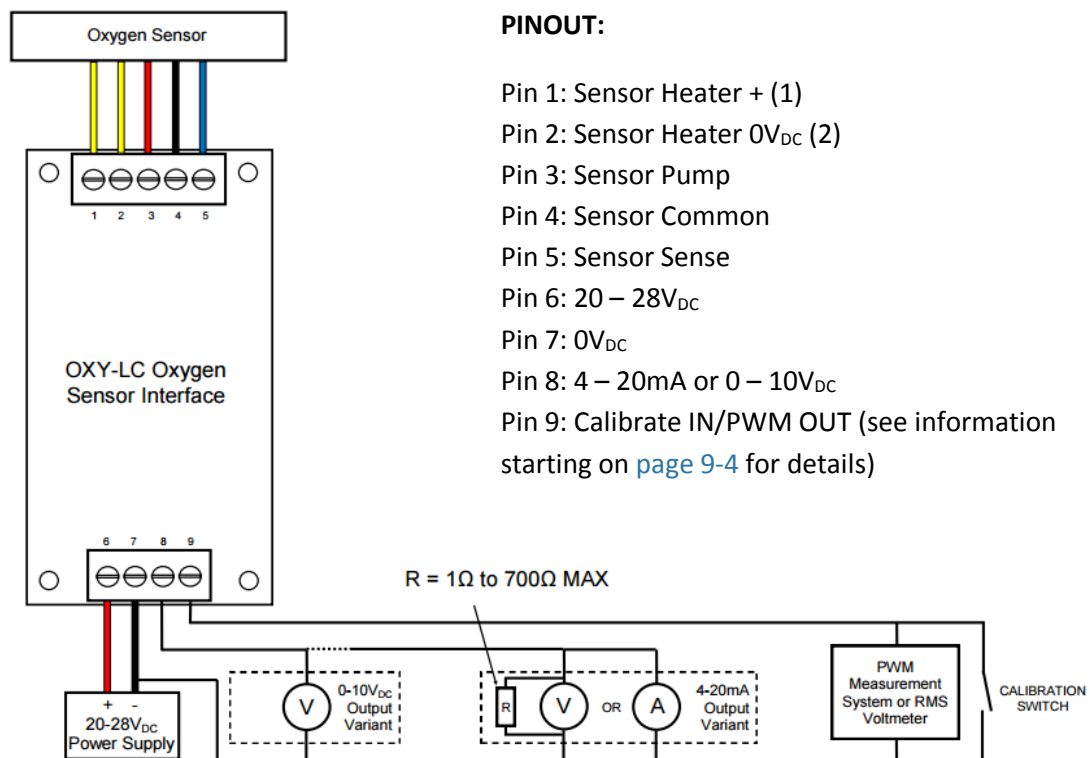

Figure 5-3 - Analogue Variant Electrical Connections

NOTES:

- Pins 8 & 9 are referenced to power supply 0V_{DC} (pin 7). A connection should be made between pin 7 and the reference or common connection of the analogue output measurement system.
- Output pins 1 through 5, refer to appropriate SST oxygen sensor datasheet for wiring/pin designations; refer to datasheets listed in [REFERENCE DOCUMENTS](#) for details.
- All SST oxygen sensors have two heater connections which should be connected to pins 1 & 2 of the interface board; the heater coil has no polarity. However, when connecting to a sensor where the sensor housing is one of the heater connections (e.g. flange mounted, O2S-FR-T4 range) pin 2 of the interface board should be connected to the housing.
- Pin 9 PWM output for diagnostics also doubles up as a calibration input.

NOTE: The calibration switch (shown in [Figure 5-3](#)) can be a mechanical switch, a relay contact, a NPN transistor or a N-Channel MOSFET.

6 INITIAL STARTUP

6.1 Commissioning Checks

Before commissioning the equipment read [2 SAFETY INSTRUCTIONS](#) on [page 2-1](#) of this document.

Complete the following essential tasks BEFORE switching the system ON for the first time:

- Ensure compliance with permissible installation position.
- Verify the device is mounted securely correctly.
- Verify the device and wiring are all undamaged.
- Ensure the cables are strain-free and not twisted.
- Ensure the device is connected properly, with all its inputs and outputs complete. All screw terminals are properly tightened.



CAUTION: Test the power supply to ensure it is delivering the correct voltage before wiring to the device.

CAUTION: Failure to test the suitability of the power supply BEFORE first power on could result in irreversible product damage that is NOT covered by warranty.

6.2 Switching ON

When the device is initially powered ON, the normal status will be as defined in [Table 6-1](#) below:

Table 6-1 - Output States

| Step | Normal Status |
|---|--|
| Apply 24V _{DC} | <ul style="list-style-type: none">• Communication OK• Supply current normal (< 1A)• Valid O₂% reading after 1minute |
| Switch sensor ON (RS485 variant) | <ul style="list-style-type: none">• Valid O₂% reading (15 – 25% O₂)• 1500 to 2500 (Modbus) |
| Sensor starts automatically after 1 minute (Analogue variants) | <ul style="list-style-type: none">• Valid O₂% reading (15 – 25% O₂)• 6 – 10V (0 – 10V output)• 13.6 – 20mA (4-20mA output) |

If a fault is detected, an error code is displayed (RS485 variant), or the analogue output will remain at 4mA or 0V. Refer to [9.4 Error Conditions](#) on [page 9-4](#).

If the error condition persists, switch the device OFF and contact technical@sstsensing.com. Refer to [9.5 Shutdown Procedure](#) on [page 9-10](#).

6.3 First-time Calibration

Calibration, or re-referencing, is required when a sensor is attached to the interface for the first time. Refer to [9.2 Calibrating](#) starting on [page 9-1](#).

7 SYSTEM CONFIGURATION

7.1 Digital Output – RS485 Modbus Variant

RS485 Modbus RTU Protocol allows the following:

1. Complete control of the sensor operation and access to all available information including sensor diagnostics, barometric pressure and pressure sensor temperature.
2. Adjustable communication settings including the ability to change the slave address of the interface allowing up to 32 devices to communicate on the same bus. Each device presents a 'single unit load' to the network. Ideal when multiple oxygen readings are required.
3. Three modes of operation; OFF, ON and Standby.

NOTE: Standby applies half the sensor heater voltage to protect the sensor from condensation and reduce the warm up time when returning to ON mode.

4. Adjustable sensor heater voltages to suit different sensor types.
5. Default calibration to 20.7% O₂ for calibration in fresh air; can be changed to any O₂ concentration for calibration with reference gases.

NOTE: Background reading is strongly recommended if there is no prior knowledge of Modbus. A good place to start is www.modbus.org.

7.1.1 RS485 Setup

The following setup should be used when using the RS485 interface:

- **Address:** 1
- **Baudrate:** 9600
- **Parity:** None
- **Stop bits:** 1

7.1.2 Register Set

7.1.2.1 Input Register

Table 7-1 Modbus Input Register Set

| Name | Register Address | Description | Action |
|-------------------------------|-------------------|---|---|
| O₂% Average | 0x7531 (30001) | = x / 100 % (Where: 0 = 0%, 2070 = 2070%) Output uses an adaptive filtering method to ensure maximum stability and response to oxygen changes | Monitor in system |
| O₂% Raw | 0x7532 (30002) | = x / 100% (Where: 0 = 0%, 2070 = 20.70%) Instantaneous oxygen reading | No action |
| Asymmetry | 0x7533 (30003) | = x / 1000 (Where: 1000 = 1.000, 1023 = 1.023) | Monitor in system (See 9.4.1 RS485 Error / Status Codes on page 9-4) |
| System Status | 0x7534 (30004) | 0 = Idle 1 = Start up routine 2 = Operating 3 = Shut down routine 4 = Standby Mode | Monitor in system |

| Name | Register Address | Description | Action |
|------------------------------------|-------------------|--|---|
| Error/Warnings | 0x7535 (30005) | Bit 0 (LSB) = Pump Error Bit 1 = Heater Voltage Error Bit 2 = Asymmetry Warning Bit 3 = O ₂ Under 0.1% Warning Bit 4 = Pressure Sensor Warning Bit 5 = Pressure Sensor Error | Monitor in system (See 9.4.1 RS485 Error / Status Codes on page 9-4) |
| Heater Voltage | 0x7536 (30006) | = x / 100 Volts (Where 443 = 4.43 Volts) | Monitor in system (See 9.4.1 RS485 Error / Status Codes on page 9-4) |
| TD Average | 0x7537 (30007) | = x * 0.1ms (Where 2033 = 203.3ms) | No action |
| TD Raw | 0x7538 (30008) | = x * 0.1ms (Where 2033 = 203.3ms) | No action |
| TP | 0x7539 (30009) | = x * 0.1ms (Where 2033 = 203.3ms) | No action |
| T1 | 0x753A (30010) | = x * 0.1ms (Where 2033 = 203.3ms) | No action |
| T2 | 0x753B (30011) | = x * 0.1ms (Where 2033 = 203.3ms) | No action |
| T4 | 0x753C (30012) | = x * 0.1ms (Where 2033 = 203.3ms) | No action |
| T5 | 0x753D (30013) | = x * 0.1ms (Where 2033 = 203.3ms) | No action |
| ppO₂ Real | 0x753E (30014) | = x * 0.1 ppO ₂ (Where 2756 = 275.6 ppO ₂) | Monitor in system |
| ppO₂ Raw | 0x753F (30015) | = x * 0.1 ppO ₂ (Where 2756 = 275.6 ppO ₂) | Monitor in system |
| Pressure | 0x7540 (30016) | mbar (See Modbus NOTE 6) | Monitor in system |
| Pressure Sensor Temperature | 0x7541 (30017) | °C (2's complement) (See Modbus NOTE 6) | Monitor in system |
| Calibration Status | 0x7542 (30018) | 0 = Calibration Idle 1 = Calibration in Progress 2 = Calibration Completed | Monitor in system (See Modbus NOTE 3) |
| Year of Manufacture | 0x7543 (30019) | =YYYY | No action |
| Day of Manufacture | 0x7544 (30020) | =DDD | No action |
| Serial Number | 0x7545 (30021) | =XXXXX | No action |
| Software Revision | 0x7546 (30022) | =RRR | No action |

7.1.2.2 Holding Register

Table 7-2 Modbus Holding Register Set

| Name | Register Address | Allowed Values | Default | Description | Action |
|--|------------------|--|---------|---|--|
| Sensor ON, OFF and Standby | 0x9C41 (40001) | 0 = Sensor OFF 1 = Sensor ON 2 = Standby | - | System Control | Set in system (See Modbus NOTE 2) |
| Clear Error Flags | 0x9C42 (40002) | 0 = IDLE 1 = Clear Errors and Warnings | - | Clear all Error flags | Set in system (See 9.4.1 RS485 Error / Status Codes on page 9-4) |
| Shutdown Delay | 0x9C43 (40003) | 0 - 65535 | 0 | x seconds | Set in system (See Modbus NOTES 1 & 7) |
| Calibration Control | 0x9C44 (40004) | 0 = Default Condition 1 = Activate Calibration 2 = Calibration Status Reset | 0 | Calibration Control | Set in system (See Modbus NOTE 3) |
| Calibration (%) | 0x9C45 (40005) | 0 - 65535 | 2070 | Calibration % Input (Where 20.70% is input as 2070) | Set in system (See Modbus NOTES 3 & 7) |
| Address | 0x9C46 (40006) | 1 - 247 | 1 | RS485 Setup Interface Slave Address | Set in system (See Modbus NOTE 4) |
| Baud | 0x9C47 (40007) | 0 = 2400 1 = 4800 2 = 9600 3 = 19200 4 = 38400 5 = 57600 6 = 115200 | 2 | RS485 Setup | Set in system if required (See Modbus NOTE 5) |
| Parity | 0x9C48 (40008) | 0 = None 1 = Odd 2 = Even | 0 | RS485 Setup | Set in system if required (See Modbus NOTE 5) |
| Stopbits | 0x9C49 (40009) | 0 = 1 1 = 2 | 0 | RS485 Setup | Set in system if required (See Modbus NOTE 5) |
| RS485 Setup Changes Apply and Save | 0x9C4A (40010) | 0 = Idle 1 = Apply and Save | 0 | Commits any changes to the RS485 Setup registers to memory. | Set in system if required (See Modbus NOTES 5 and 7) |
| Applied Heater Voltage | 0x9C4B (40011) | 0 = 4V _{DC} 1 = 4.2V _{DC} 2 = 4.35V _{DC} 3 = 4.55V _{DC} | - | Heater setup | Set in system if required (See Modbus NOTE 7) |
| Heater Voltage Changes Apply and Save | 0x9C4C (40012) | 0 = Idle 1 = Apply and Save | 0 | Commits any changes to the heater setup registers to memory | Set in system if required (See Modbus NOTES 7 and 8) |

7.1.2.3 Modbus Notes

1. The shutdown delay allows the heater voltage to remain ON after the sensor has stopped taking measurements. Use this in applications where there is high humidity and especially if there are also aggressive components in the measurement gas (refer to [AN-0050, Zirconia O₂ – Sensor Operation and Compatibility Guide](#)). By applying a shutdown delay the heater keeps the sensor hot until the rest of the application cools down. This encourages condensation to form elsewhere and not on the sensor which could lead to corrosion of the sensing cell. The length of the delay in seconds should be set to suit the application cool down time. The shutdown delay time is stored in memory and retained after power loss.
2. Standby Mode is used when O₂ measurements are infrequent but it is not desirable to wait for the full warm up time experienced going from OFF mode to ON mode. In Standby Mode, the heater voltage is reduced to 2V_{DC} to decrease power consumption whilst keeping the sensor warm enough to protect it from condensation in humid environments.
3. Calibration occurs when the sensor has been operating in the calibration gas for at least 5 mins. At this point, send the known calibration gas value to the *Calibration (%)* holding register (for fresh air input '2070' for 20.70% O₂) then set the *Calibration Control* holding register to '1'. The interface will ONLY calibrate after the sensor has been in ON mode (heater voltage active) for more than 5 minutes; if a calibration is attempted during this period the calibration process will pause until the 5-minute period has elapsed. The *Calibration Status* input register will remain at '1' until the calibration process is complete at which point it will change to '2' (Calibration Completed). Once calibration completes, the *Calibration Control* holding register can be set to '2' to return the *Calibration Status* input register back to '0' (Calibration Idle) ready for the any future calibrations. New calibration values are stored in memory and retained on power loss. The value inserted into the *Calibration (%)* holding register is also stored in memory so does not need to be reinserted before each calibration unless the calibration gas is going to change.
4. The *Address* holding register allows the interface slave address to be changed between 1 & 247. This is only applicable if there are multiple boards or devices on the same communication lines.
5. The communication settings can be adjusted to suit the application. Changes are only implemented when the *RS485 Setup Changes Apply and Save* holding register is set to '1'. After applying new settings, communication is lost and the interface will return to its idle state (no O₂ measurements) until the master is reconfigured to the new settings at which point the sensor will have to be switched ON again. Any changes made are retained on power loss.
6. *Pressure* and *Pressure Sensor Temperature* readings are for indication only. The pressure sensor has a typical accuracy of ±2mbar in the pressure sensor temperature range of 0 to 70°C. As the interface has a switch mode power supply to regulate the sensor heater voltage, the pressure sensor temperature can be 10 to 20°C higher than the ambient temperature. The pressure sensor temperature reading is output through Modbus in 2's complement to allow for negative temperatures. For example, 20°C is 20 in decimal, 0x0014 in hex and 000000000010100 in 16-bit binary; -40°C is 65496 in decimal, 0xFFD8 in hex and 111111111011000 in 16-bit binary.
7. The heater voltage applied to the sensor can be adjusted to suit the variant of sensor attached. Different sensors require different heater voltages depending on the type of porous filter surrounding the sensing element (determines the response time) and the length of cable between the sensor and interface. Refer to the heater voltage information in the sensor datasheet; refer to [REFERENCE DOCUMENTS](#) for details. Changes are only implemented when the *Heater Voltage Changes Apply and Save* holding register is set to '1'. After applying new settings, the interface returns to its idle state (no O₂ measurements) and the sensor will have to be switched back ON again. Any changes made are retained on power loss.
8. Flash memory has a finite number of allowed writes, use appropriately.

7.2 Analogue Output – 0-10V_{DC} and 4-20mA Variants

7.2.1 Output Values

Table 7-3 Analogue Output Values

| O ₂ % | Output Values | | | |
|------------------------|------------------------------|---------------------------|--------------------------|---------------------------|
| | 0 – 10V _{DC} output | | 4 – 20mA output | |
| | 0.1 – 25% O ₂ | 0.1 – 100% O ₂ | 0.1 – 25% O ₂ | 0.1 – 100% O ₂ |
| 20.7% | 8.28V _{DC} | 2.07V _{DC} | 17.25mA | 7.34mA |
| 100% | - | 10V _{DC} | - | 20mA |
| 90% | - | 9.0V _{DC} | - | 18.4mA |
| 25% | 10V _{DC} | 2.5V _{DC} | 20mA | 8mA |
| 5% | 2.0V _{DC} | 0.5V _{DC} | 7.2mA | 4.8mA |
| 0.1% (see NOTE) | 0.04V _{DC} | 0.01V _{DC} | 4.06mA | 4.02mA |

NOTE: The analogue output ranges actually represent 0 to 25% or 0 to 100% O₂ however as SST's oxygen sensors cannot measure below 0.1% O₂ this value is displayed as the range minimum.

7.2.2 PWM Output

PWM output characteristics:

- **Frequency:** 1kHz
- **V_{OUT} (PWM):** 3.3V_{DC}

PWM System Requirements:

- Frequency Measurement: 3.3V_{DC} compatible input. Minimum sample frequency of 8kHz.
- Alternative RMS Voltage measurement: Any RMS input voltmeter. RMS Voltage Vs Duty Cycle is as follows.

Table 7-4 Duty Cycle Vs RMS Voltage

| Duty Cycle (ON time) | Approximate RMS Voltage |
|----------------------|-------------------------|
| 0% | 0V _{DC} |
| 25% | 0.83V _{DC} |
| 50% | 1.65V _{DC} |
| 75% | 2.48V _{DC} |
| 100% | 3.3V _{DC} |

8 OPERATION

8.1 General Operation

The following high-level process map gives an overview of the general operating procedure. For more in-depth information, refer to the lower-level maps in the following sections which detail the process stages.

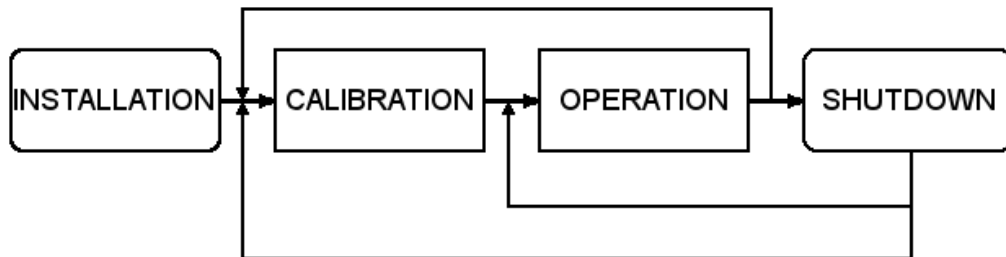

8.2 Operating Tips

To ensure the best performance from your equipment it is important that the attached oxygen sensor is installed and maintained correctly. Refer to [AN-0050, O₂ Sensors – Zirconia Dioxide Sensor Operation and Compatibility Guide](#) for some useful sensor operating tips and a list of gases and materials that must be avoided to ensure a long sensor life.

9 MAINTENANCE



WARNING: BEFORE performing any type of maintenance on the equipment read [2 SAFETY INSTRUCTIONS](#) on [page 2-1](#) of this document.

WARNING: The attached oxygen sensor is heated to over 700°C (1300°F) and is a source of ignition. Ensure the sensor is cool before attempting to touch or service the equipment.

9.1 Cleaning

If installed in a housing, clean the outer surfaces of the housing regularly with non-abrasive materials to prevent a buildup of contaminants. Isopropyl alcohol (IPA) and a lint-free cloth is recommended.



CAUTION: Never use any of the following for cleaning purposes:

- Chemical cleaning agents
- High-pressure water or steam

9.2 Calibrating

SST Sensing's range of zirconium oxygen sensors do not directly measure the oxygen concentration but instead measure the partial pressure of oxygen within the measurement gas. In order to output an oxygen concentration (%) the system must be calibrated, or more specifically, re-referenced in a known gas concentration, typically fresh air.

Regular calibration removes the effects of application contamination and also eliminates any sensor drift that may occur during the first few hundred hours of operation.

For maximum accuracy in the range 0.1 to 25% O₂ it is recommended that a calibration to 20.7% O₂ should occur every time the sensor is known to be in fresh air (20.7% O₂ takes into account typical humidity levels).

Calibration is achieved by initiating a calibration routine and monitoring the status of the output.

A software delay prevents calibration from being completed before the zirconia sensor has been powered ON for 5 minutes. If a calibration is initialised during this delay the unit will calibrate after the 5 minutes have elapsed.

9.2.1 Calibration Process

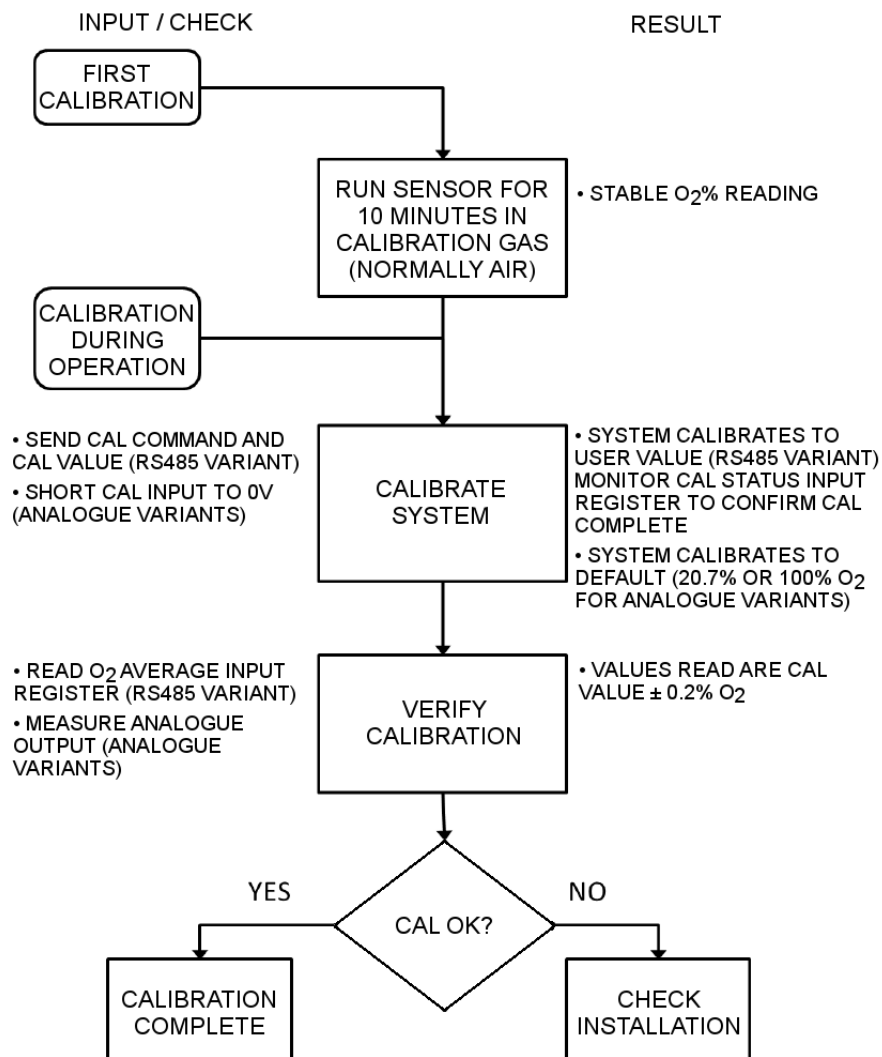

9.2.2 Calibration Routine – RS485 Variant

- Place the sensor probe in the calibration gas, typically fresh air.
 - Allow the output to stabilise for at least 5 minutes (10 minutes if powering from cold).
 - Send the known calibration gas value to the *Calibration (%)* holding register (for fresh air input '2070' for 20.70% O₂) then set the *Calibration Control* holding register to '1'.
- NOTE:** The interface will ONLY calibrate after the sensor has been in ON mode (heater voltage active) for more than 5 minutes; if a calibration is attempted during this period the calibration process will pause until the 5-minute period has elapsed.
- The *Calibration Status* input register remains at '1' until the calibration process is complete at which point it will change to '2' (Calibration Completed).
 - Once calibration completes, the *Calibration Control* holding register can be set to '2' to return the *Calibration Status* input register back to '0' (Calibration Idle) ready for the any future calibrations.

NOTE: New calibration values are stored in memory and retained on power loss. The value inserted into the *Calibration (%)* holding register is also stored in memory so does not need to be reinserted before each calibration unless the calibration gas is going to change.

9.2.3 Calibration Routine – Analogue Variants (PWM)

1. Place the sensor probe in the calibration gas, typically fresh air.
2. Allow the output to stabilise for at least 5 minutes (10 minutes if powering from cold).
3. Referring to [Figure 5-3](#) on [page 5-4](#), a calibration switch is used to connect the Cal IN/PWM OUT (pin 9) output to 0V_{DC} (pin 7). When the switch is closed (for a minimum of 1s) the interface will calibrate the analogue output as outlined in the table below.
NOTE: The interface will only calibrate after the sensor has been in ON mode (heater voltage active) for more than 5 minutes, if a calibration is attempted during this period the calibration process will pause until the 5-minute period has elapsed.
4. The output will now track to the correct value for the calibration gas.
5. Calibration is complete. Calibration values are retained on power loss.

| Analogue Output Variant | Output Calibrated to / Required Calibration Gas |
|---------------------------|---|
| 0.1 - 25% O ₂ | 20.7% O ₂ / Fresh air |
| 0.1 - 100% O ₂ | 100% O ₂ / Pure oxygen |

9.3 Diagnostic Routine

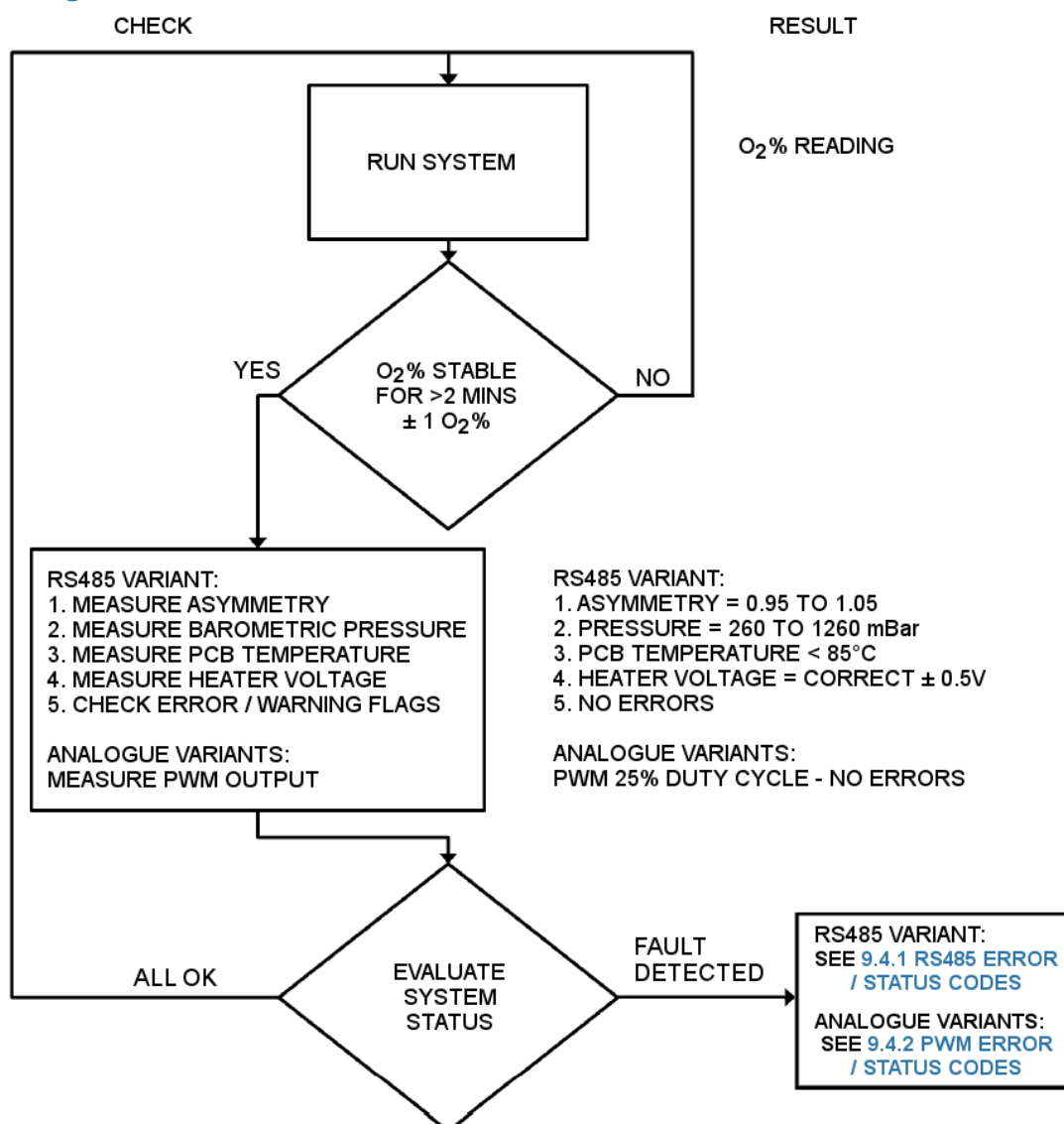

9.4 Error Conditions

If the oxygen sensor is incorrectly connected or is damaged, an error code is displayed on the RS485/PWM output and the analogue outputs will default to 4mA and 0V. Refer to the following sub-sections for a list of RS485/PWM codes.

If an error condition occurs the unit should be powered down and all wiring checked before reapplying the power. Refer to [9.5 Shutdown Procedure](#) on [page 9-10](#) for the correct power down procedure.

NOTE: Incorrect shutdown can result in sensor damage.

If the error condition remains, the O₂ sensor is damaged and should be replaced.

9.4.1 RS485 Error / Status Codes

Hex value output from the Error/Warnings input register should be converted to a 6-bit binary value. Each bit of the 6-bit word represents an error or warning as described in the table below. This method of displaying errors allows multiple errors or warnings to be displayed at the same time.

Example; Hex value = 5, binary representation = 000101, Bit 0 = 1 (Pump Error) and Bit 2 = 1 (Asymmetry Warning).

NOTE: Only the first 6 bits of the converted Hex value should be used for error detection. Other bits are reserved and may be used by SST for diagnostic purposes.

| Bit | Error Description | Possible Causes | Description / Actions (Final Action) |
|----------------|---|--|--|
| Bits [0:5] = 0 | No Error | System OK | No Action |
| Bit [0] = 1 | Sensor Pump Error (Interface forced into Sensor OFF mode) | Incorrect Sensor Wiring/Damaged Sensor | <ol style="list-style-type: none"> 1. Power down the interface. 2. Check the sensor wiring, orientation and connections referring to 5 INSTALLATION on page 5-4. 3. Check the sensor attached is the correct variant for the selected heater voltage (Refer to appropriate datasheet or AN-0076, Zirconia O₂ Sensor Selection Guide). 4. Repower the interface and put the sensor back into ON mode, if the error remains the sensor is no longer functioning correctly which is usually a sign of misuse (Refer to AN-0050, Zirconia O₂ – Sensor Operation and Compatibility Guide). <p>(Replace Sensor)</p> |

| Bit | Error Description | Possible Causes | Description / Actions (Final Action) |
|-------------|--|---|--|
| Bit [1] = 1 | Heater Voltage Error (Interface forced into Sensor OFF mode) | Interface Temperature out of Range Measured Heater Voltage out of tolerance for more than 30s. | Ensure ambient temperature has not exceeded the maximum rating of 70°C. Read Pressure Sensor Temperature register and ensure the PCB temperature is below 85°C. <ol style="list-style-type: none"> Put the sensor back into ON mode and measure the sensor heater voltage during the first 60s across interface Pins 1 & 2 (See page 5-4). If the heater voltage is 0V then remove power from the interface before disconnecting the two sensor heater wires. Repower the interface, restart the sensor then re-measure the heater voltage during the first 60s. If the heater voltage has returned to normal, then the sensor heater coil has gone short circuit which can be confirmed with a multi-meter. (Replace Sensor) If the heater voltage remains at 0V then the switch mode power supply on the interface has been electrically damaged (Replace Interface) |
| Bit [2] = 1 | Asymmetry Warning | Sensor waveform asymmetry out of specification for more than 30s | The value in the Asymmetry input register should be between 0.95 and 1.05 when the sensor is in a steady oxygen concentration. However, when the O ₂ level is changing the waveform period is also changing so the asymmetry value can vary outside of this range. If the asymmetry value falls outside this range for more than 30s an asymmetry warning will be set. Asymmetry warnings can be generated if the sensor has reached its end of life or has been damaged through misuse (Refer to AN-0050, Zirconia O₂ – Sensor Operation and Compatibility Guide). (Replace Sensor) |
| Bit [3] = 1 | O ₂ Under 0.1% Warning | Sensor measuring less than 0.1% oxygen for more than 30s. | Ensure measuring gas has at least 0.1% oxygen which is essential for correct sensor operation. Sustained use below 0.1% O ₂ will cause permanent readout errors. Low oxygen in a reducing atmosphere will accelerate sensor damage. (Refer to AN-0050, Zirconia O₂ – Sensor Operation and Compatibility Guide). |

| Bit | Error Description | Possible Causes | Description / Actions (Final Action) |
|-------------|-------------------------|--|--|
| Bit [4] = 1 | Pressure Sensor Warning | Atmospheric pressure value outside of the specified range for more than 30s. | <ol style="list-style-type: none"> 1. Ensure the sensor and interface are being operated within the specified pressure range of 260 to 1260mbar. 2. If the atmospheric pressure is correct then the out of range reading in the Pressure input register may be due to the pressure sensor being damaged either mechanically or by ESD damage due to incorrect handling procedures. (Replace Interface) |
| Bit [5] = 1 | Pressure Sensor Error | Communication with the Pressure Sensor has not been established or has broken. | <ol style="list-style-type: none"> 1. Communication with the pressure sensor has ceased due to the pressure sensor being damaged either mechanically or by ESD damage due to incorrect handling procedures. (Replace Interface) 2. If the pressure sensor fails, the interface reverts back to a non-pressure compensated oxygen reading allowing continued use of the interface until it can be replaced. NOTE: In this mode of operation, no ppO₂ measurement is available. The interface will require regular re-calibration to overcome the effects of atmospheric pressure fluctuations. Refer to 9.2.2 Calibration Routine – RS485 Variant on page 9-2. |

NOTE: The error flags can be cleared by setting the *Clear Error Flags* holding register to '1'. This register returns to '0' when complete.

9.4.2 PWM Error / Status Codes

| Duty Cycle (ON time) | Analogue Output Status | Error Description | Possible Causes | Response |
|----------------------|--|--------------------------------|---|---|
| 25% | Proportional to O ₂ | No Error | System OK | No Action |
| 50% | 4mA or 0V _{DC} (Interface is forced into an idle state and analogue outputs go to their minimum value) | System Error for more than 30s | <p>Interface over temperature</p> <p>Sensor heater short or heater voltage supply damaged</p> | <ol style="list-style-type: none"> 1. Power down the interface. 2. Check all wiring, orientations and measurement connections as described in 5 INSTALLATION on page 5-4. 3. Ensure ambient temperature has not exceeded the maximum rating. <ol style="list-style-type: none"> 1. Power cycle the interface supply voltage and measure the sensor heater voltage during the first 60s across pins 1 and 2 of the interface. 2. If the heater voltage is 0V then remove the power again before disconnecting the two sensor heater wires. 3. Repower the interface and re-measure the heater voltage during the first 60s. If the heater voltage has returned to normal, then the sensor heater coil has gone short circuit which can be confirmed with a multi-meter. (Replace Sensor) 4. If the heater voltage remains at 0V then the switch mode power supply on the interface has been electrically damaged. (Replace Interface) |

| Duty Cycle (ON time) | Analogue Output Status | Error Description | Possible Causes | Response |
|----------------------|---|--------------------------------|--|---|
| 50% | Proportional to O ₂ (Interface continues to operate with possible output errors) | System Error for more than 30s | Analogue output error Pressure sensor warning/error | <ol style="list-style-type: none"> 1. Power down the interface. 2. Check all wiring, orientations and measurement connections/loads as described in 5 INSTALLATION on page 5-1. 3. Retest the analogue output and PWM status to see if the error condition has been resolved. <p>Ensure the sensor and interface are being operated within the specified pressure range of 260 to 1260mbar. If the atmospheric pressure range is ok, the pressure sensor has been damaged either mechanically or by ESD damage due to incorrect handling procedures.</p> <p>(Replace Interface) If the pressure sensor fails, the interface reverts back to a non-pressure compensated oxygen reading allowing continued use of the interface until it can be replaced.</p> <p>NOTE: The interface will require regular re-calibration to overcome the effects of atmospheric pressure fluctuations. Refer to 9.2.3 Calibration Routine – Analogue Variants (PWM) on page 9-3.</p> |
| 75% | 4mA or 0V _{DC} (Interface is forced into an idle state and analogue outputs go to their minimum value) | Sensor Error for more than 30s | Sensor pump failure | <ol style="list-style-type: none"> 1. Power down the interface. 2. Check the sensor wiring, orientation and connections. 3. Check the sensor attached is the correct variant for the selected heater voltage. 4. Repower the interface, if the error remains the sensor is no longer functioning correctly which is usually a sign of misuse (Refer to AN-0050, Zirconia O₂ – Sensor Operation and Compatibility Guide). <p>(Replace Sensor)</p> |

| Duty Cycle (ON time) | Analogue Output Status | Error Description | Possible Causes | Response |
|----------------------|---|--------------------------------|---|--|
| 75% | Proportional to O ₂ (Interface continues to operate with possible output errors) | Sensor Error for more than 30s | Asymmetry error Measurement < 0.1% O ₂ | <ol style="list-style-type: none"> 1. Power down the interface. 2. Check the sensor wiring, orientation and connections. 3. Check the sensor attached is the correct variant for the selected heater voltage. 4. Repower the interface, if the error remains the sensor is no longer functioning correctly. Asymmetry warnings can be generated if the sensor has reached its end of life or has been damaged through misuse (Refer to AN-0050, Zirconia O₂ – Sensor Operation and Compatibility Guide). (Replace Sensor) <p>Ensure measuring gas has at least 0.1% oxygen which is essential for correct sensor operation. Sustained use below 0.1% O₂ will cause permanent readout errors. Low oxygen in a reducing atmosphere will accelerate the sensor damage (Refer to AN-0050, Zirconia O₂ – Sensor Operation and Compatibility Guide).</p> |
| 0 or 100% | | System Failure | Interface not powered correctly or irreversibly damaged PWM output not connected to PWM measurement system correctly | <ol style="list-style-type: none"> 1. Check all wiring and ensure the supply voltage is within the specified limits. 2. Check the power supply is capable of supplying the required current. (Replace Interface) 3. Check all wiring and ensure the 0V_{DC} of the interface is common to that of the measurement systems. |

9.5 Shutdown Procedure

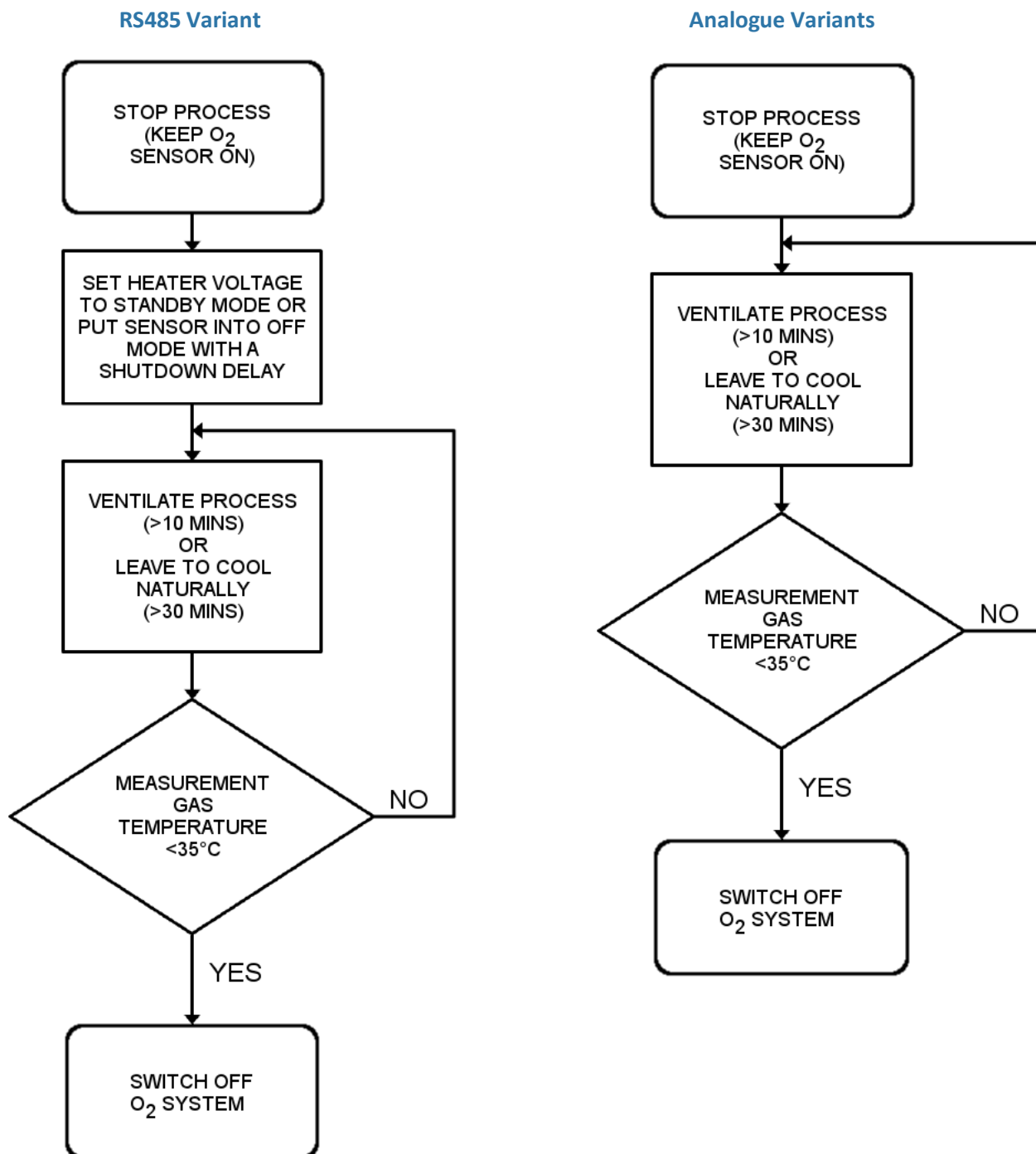

9.6 Disposal

The OXY-LC should be disposed of as electrical waste. Please observe your local regulations.

REFERENCE DOCUMENTS

Other documents in the Zirconium Dioxide product range are listed below; this list is not exhaustive, always refer to the [SST website](#) for the latest information.

| Part Number | Title |
|-------------|--|
| AN-0043 | Zirconia O ₂ Sensor Operating Principle and Construction Guide |
| AN-0050 | Zirconia O ₂ Sensor Operation and Compatibility Guide |
| AN-0076 | Zirconia O ₂ Sensor Selection Guide |
| DS-0058 | OXY-LC Oxygen Sensor Interface Board Datasheet |
| QS-001 | OXY-LC Oxygen Sensor Interface Board Quick Start Guide |
| DS-0044 | Zirconia O ₂ Sensors Flange Mounted Series Datasheet |
| DS-0051 | Zirconia O ₂ Sensors Miniature Series Datasheet |
| DS-0052 | Zirconia O ₂ Sensors Probe Series - Short Housing Datasheet |
| DS-0053 | Zirconia O ₂ Sensors Probe Series - Screw Fit Housing Datasheet |
| DS-0055 | Zirconia O ₂ Sensors Oxygen Measurement System Datasheet |
| DS-0072 | OXY-COMM Oxygen Sensor Datasheet |
| DS-0073 | OXY-Flex Oxygen Analyser Datasheet |
| DS-0074 | O2I-Flex Oxygen Sensor Interface Board Datasheet |
| DS-0122 | Zirconia O ₂ Sensors Probe Series - OEM Screw Fit Housing Datasheet |
| DS-0131 | Zirconia O ₂ Sensors Probe Series - Long Housing Datasheet |

CAUTION

Do not exceed maximum ratings and ensure sensor(s) are operated in accordance with their requirements.
Carefully follow all wiring instructions. Incorrect wiring can cause permanent damage to the device. Zirconium dioxide sensors are damaged by the presence of silicone. Vapours (organic silicone compounds) from RTV rubbers and sealants are known to poison oxygen sensors and MUST be avoided. Do NOT use chemical cleaning agents.

Failure to comply with these instructions may result in product damage.

INFORMATION

As customer applications are outside of SST Sensing Ltd.'s control, the information provided is given without legal responsibility. Customers should test under their own conditions to ensure that the equipment is suitable for their intended application.

For technical assistance or advice, please email: technical@sstsensing.com

General Note: SST Sensing Ltd. reserves the right to make changes to product specifications without notice or liability. All information is subject to SST Sensing Ltd.'s own data and considered accurate at time of going to print.

SST SENSING LIMITED, 5 HAGMILL CRESCENT, SHAWHEAD INDUSTRIAL ESTATE, COATBRIDGE, UK, ML5 4NS
www.sstsensing.com | e: sales@sstsensing.com | t: +44 (0)1236 459 020 | f: +44 (0)1236 459 026