

DYNAMOMETER INSTRUCTIONS

Single Element Multi-Component Dynamometer

Model: MC5-6

Serial Number _____

November 8, 2000

**Advanced Mechanical Technology, Inc.
176 Waltham Street
Watertown, Massachusetts 02472
USA**

Table of Contents

Section

1. General Description

2. Installation and Operation

3. Calibration

3.1 Calibration Procedure

3.2 Main Sensitivity Terms

3.3 Cross Talk Matrix

3.4 Ten Point Loading

4. Maintenance

5. Warranty

Appendix A- Dynamometer Description

Appendix B- Sensitivity Calibrations

Appendix C- Ten Point Loading Tables

1.0 General Description

The MC5 force/torque load cell measures loads in the mid-range of our multi-component transducers. These precision instruments feature high stiffness, high sensitivity, low crosstalk, excellent repeatability and long-term stability. They exhibit the inherent ruggedness of bonded strain gage transducers and they incorporate seals to prevent water and oil contamination by splashing. They are not waterproof or capable of being submerged in liquids.

The MC5 is available with one to six outputs corresponding to F_x , F_y , F_z , M_x , M_y , and M_z . Standard vertical load capacities are 5,340 N (1250 lb), 10,680 N (2,500 lb), 21,360 N (5000 lb) and 42,720 N (10,000 lb), and horizontal load capacities are half of the vertical rating. The model number designation MC5-X-XXX refers to the number of channels, and capacity. The “-X-“ refers to the number of channels the transducer measures. For example “-6-“ means all six components have been selected. The last group of numbers “-XXXX” refer to the vertical load capacity. For example “-5000” means a 5000 pound rating . The ratings are always given for the vertical (F_z) load. The transducer construction consists of a single cylindrical strain element. Strain gages are placed on the outer diameter of the strain element and wired in four arm bridges. The wiring is attached to the connector at the side.

The instrument has a 12.57 cm (4.95 in) inch diameter top and bottom mounting surfaces equipped with mounting holes and threaded inserts. A high-strength aluminum alloy (7075-T6) is used throughout to withstand harsh environments and a durable anodized finish protects the exterior from corrosion. Elastomeric O-ring seals provide internal protection of the strain gages and wiring, and the strain gages are coated to further insure long life and consistent, reliable performance.

A brochure showing the overall dimensions, mounting holes, and coordinate system conventions of this transducer is shown in Appendix A. Also in Appendix A is a specification sheet for this transducer and the pinout for the connector. Appendix B includes the sensitivity calibration terms while Appendix C gives the Ten Point Loading tables.

2. Installation and Operation

2.1 Installation

The transducer should be mounted between the load input and output devices using the threaded holes provided and described in the drawing of Appendix A. It is important that the surfaces to be attached are flat, clean, and lubricant free. Any movement of the transducer relative to the mounting surfaces during loading could cause unwanted hysteresis and zero shift during a measurement.

Recommended bolt tightening for the transducer depends on the size of the bolt, material, grade, bolt lubricant, use of inserts (helicoil) etc. The notes of Appendix A make suggestions for the recommended torque for the specific transducer and fastener indicated. Since the user will be performing the installation, they must follow their own guidelines for the fastener and conditions present at the installation. Ours is simply one method for fastening and is not necessarily the best for the installation. The user is the best judge of this. If unsure of how to best install the transducer please contact AMTI.

One important consideration in the operation of the transducer is the environmental conditions. The obvious concern is that the transducer be operated as intended and in the environment for which it was designed. Less obvious is the effect of some of the more subtle factors. One such factor is temperature. While the transducer output is not very temperature dependent, if possible the transducer should be in thermal equilibrium. Output data during swings in temperature may result in zero shift errors. In general, this is true not only of the sensors, but also the electrical conditioning equipment such as amplifiers. It is recommended that the system be turned on and left to stabilize for at least one hour before taking data. In fact, unless circumstances will not allow it, it is recommended that the system be left on continuously during long duration test periods.

A multi-component transducer is a sophisticated device and making recommendations for safe overloads are difficult. In addition, there is confusion between “overload limit”, “factor of safety”, etc. First a clarification of the difference between “factor of safety” and “overload limit” should be made. “Factor of safety” is a common engineering term and is somewhat a misnomer. The “factor of safety” is the ratio of the yield strength divided by the design stress. When we design a transducer, the strain elements are designed to reach the yield strength at three (3) times the design stress. **This does not mean that the transducer can be subjected to three (3) times the load without damaging the transducer.** The yield strength can vary, so AMTI recommends the use of the “overload limit” to define safe loads to which the transducer can be subjected. The listed capacities for uni-directional loading can be exceeded by 50% (1.5 times rated capacity) without damaging the transducer. It should be pointed out that the transducer is not calibrated above its rated capacity¹. The “overload limit” only relates to avoiding damage and not extending the useful range. The first evidence of serious overload will be

¹ It may actually be calibrated for full output below its capacity if requested by the customer.

a significant zero shift. This does not always indicate permanent damage, however, it should be recalibrated.

Warning! Extremely high impulse forces will result if the dynamometer is dropped. These are rugged instruments and should provide years of trouble-free operation when handled correctly. However, because of its mass, forces exceeding its safe range may result due to rapid deceleration upon being dropped onto a hard surface for even a short distance.

2.2 Operation

These instruments use metal foil strain gages to measure the forces and moments present. Strain gages are resistive elements that when "strained" change in resistance. Properly placed gages can provide information on strains in several directions. The measurement is accomplished by placing these gages in wheatstone bridges and applying an excitation voltage to the input of the bridge and measuring the output voltage at the bridge output. The output of the gages is very low and must be amplified to provide a useful output. Typical amplifier gains can range up to 4000. A discussion of the operation of AMTI or other manufacturer's amplifiers can be found in the amplifier operating manual.

The basic output of the strain gages is the gage sensitivity(s). This term is expressed as follows:

For Forces

$$S = \text{microVolts/Volt(Excitation)-lb}$$

$$S = \text{microVolts/Volt(Excitation)-N}$$

For Moments

$$S = \text{microVolts/Volt(Excitation)-lb-in}$$

$$S = \text{microVolts/Volt(Excitation)-N-m}$$

When your dynamometer is delivered, the values of the calibrated sensitivities are provided in Appendix B. The calibration procedure will be explained in Section 3. The governing equation that shows the relationship among the load, sensitivity, gain, output voltage, and excitation voltage is presented below:

$$F_f(\text{Load}) = V_{\text{fout}} / (V_{\text{fexc}} * S_f * G_f * 1 \times 10^{-6})$$

where:

- F_f is the load in the f direction in pounds or Newtons
- V_{fout} is the amplified voltage output for the f channel in volts.
- V_{fexc} is the excitation voltage applied to the bridge in volts
- G_f is the amplifier gain

- S_f is the calibrated gain sensitivity in microVolts/Vexc-lb
- or
- S_f is the calibrated gain sensitivity in microVolts/Vexc-N

For moments the above equations are the same except the moment sensitivities (S_m) are used and the resultant output is the moment M_m .

One important factor to keep in mind is that the gain and excitation voltage may differ for each channel. Thus the subscripts f and m are usually replaced by the load or moment direction x, y, or z.

3.0 Calibration

3.1 Calibration Procedure

AMTI calibrates every sensor it manufactures to rigorous industry standards. Our calibration facility and equipment is ISO 9001 certified and surveyed every six months. All of the equipment used in the manufacture of our sensors and the calibration equipment are on an annual calibration schedule.

The transducers are typically calibrated in eight (8) different load locations which will provide data for F_x , F_y , F_z , M_x , M_y , M_z , $-M_x$, and $-M_y$. The calibration sheets provided in Appendix C will indicate the loads used for this particular dynamometer. The loads are applied the same way for all standard transducers and the specific details are provided in Appendix A. The general procedure will be described in this section.

First a description of the axes convention is given. Figure 1 shows the X, Y, and Z conventions of the transducers AMTI manufactures. The standard right hand rule is followed as the axis convention. The positive F_z axis always points vertically down in our transducers. If the transducer has a side electrical connector then the positive Y axis points in the direction of the transducer from the side of the transducer with the connector. The +X axis is to the left of the +Y axis as shown in the figure. The axis location can always be found in the transducer drawing or brochure for the specific transducer.

The location of the true X and Y plane is approximately the midpoint of the transducer along the Z axis. Included in every calibration is the geometric location of this origin relative to the top of the sensor, along the Z axis. It can be found in Table B.1 of Appendix B.

In the calibration procedure the Z load locations are referenced to the top of the dynamometer rather than the center of the transducer. This is an artifact of the calibration procedure and should not be confused with the true origin. Another feature of our calibration procedure is the use of fixtures to apply the loads. In general the dynamometer is mounted between plates to which loads are precisely applied using fixtures that insure

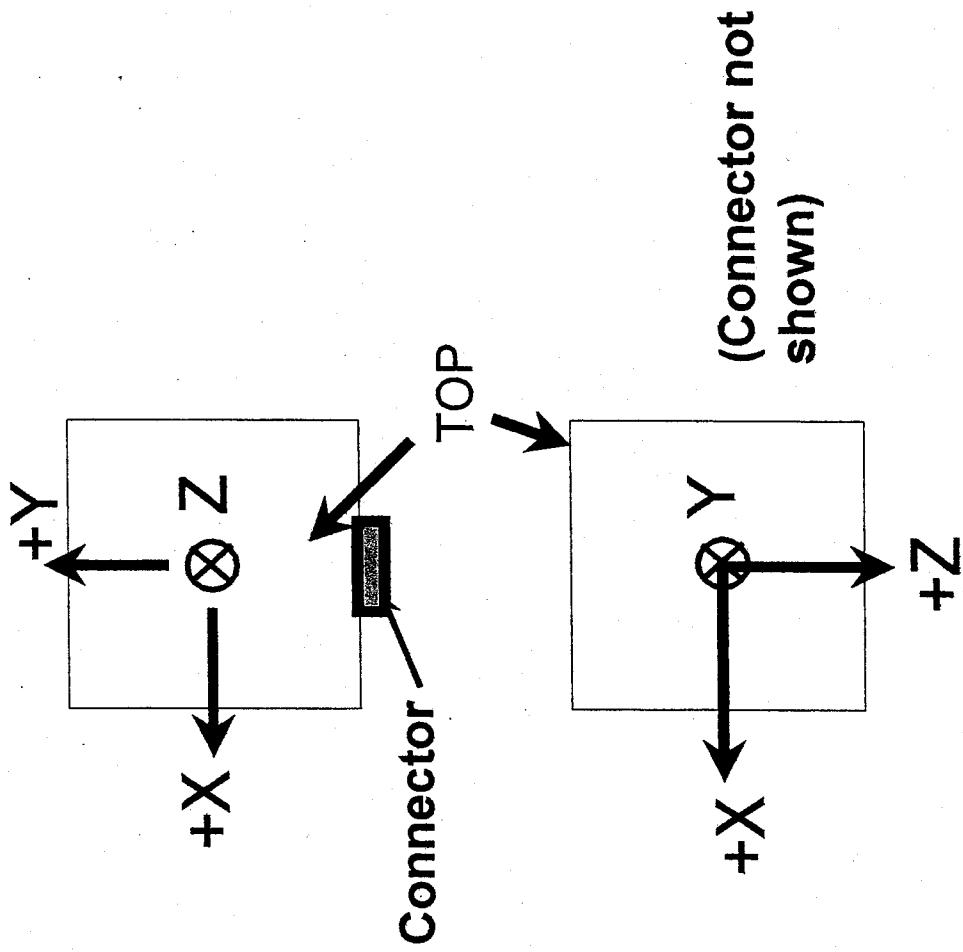

Fig. 1 Axis Convention

the application of pure loads in the direction applied. One can see the difficulty in trying to directly apply a load to a round transducer.

In general a 10 point calibration is performed for each load location. The transducer is installed into the calibration stand. Prior to applying the load zeros are taken. The load is then slowly applied up to the specified maximum working load.² As the load increases the computerized calibration system takes data at 10% increments of the maximum load up to 100% and then takes the same data as the load is released slowly. This is referred to as a "10 point" calibration. All channels of data are taken for every load point. This data is presented in Appendix C.

Following is a description of the applied loads in the F_x , F_y , F_z , M_x , M_y , M_z , $-M_x$, and $-M_y$ directions. Your calibration may only include some of these depending on the specification of your transducer. The location of the loads is shown as x , y , and z in the following figures. The numeric values of the location and magnitude of the loads can be found in Appendix A.

F_x & F_y Loads

The upper left corner of Figure 2 shows the application of the F_x calibration load. Two views of the transducer are shown, the top view and the side view. As can be seen in the figure, the F_x force is applied in the $+X$ direction at $Y=0$, $X=-x$, and $Z=+z$. The x , y , or z dimensions listed in Appendix A for your transducer may exceed the linear dimension of the transducer. This is because the calibration fixture to which the load was applied usually has greater dimensions than the sensor. The actual locations of the F_x (and other loads) are given in Appendix A. The F_y calibration loading can be found in the upper right of Fig. 2. It is basically the same as the F_x except rotated 90 degrees.

F_z Load

The application of the F_z load is at the geometric center of the top pushing down in the $+Z$ direction. The coordinates for the location relative to the top are $X=0$, $Y=0$, and $Z=0$. Some explanation is required at this point. The preceding dimensions are given relative to the center of the top. These dimensions are not referenced to the origin. The actual calibrations will provide the exact location of the effective X , Y , and Z origin. The effective location of the origin is determined using the M_x and M_y sensitivities to calculate the actual zero position when the F_z force is applied.

² This may or may not be equal to the maximum rated load. The customer can specify a different maximum load for calibration if they desire.

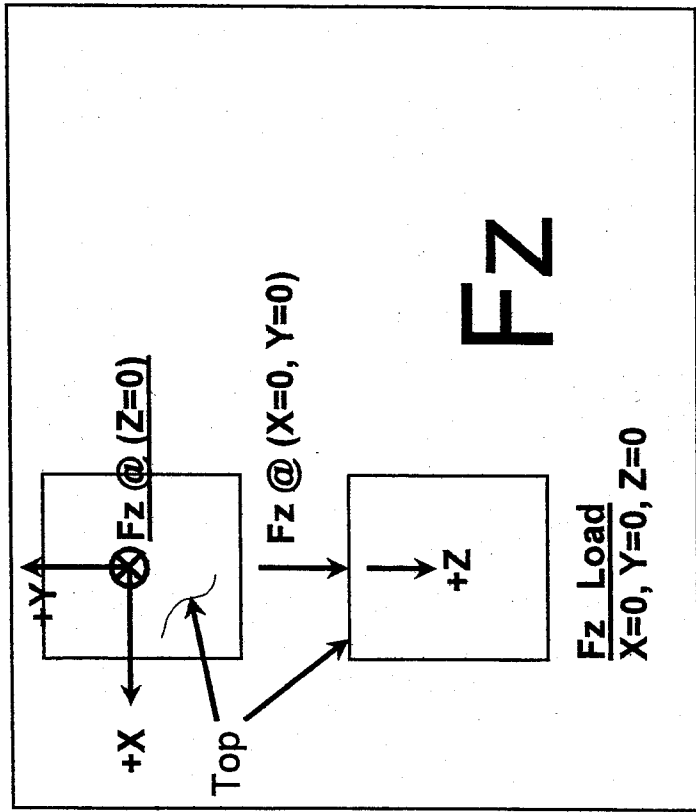
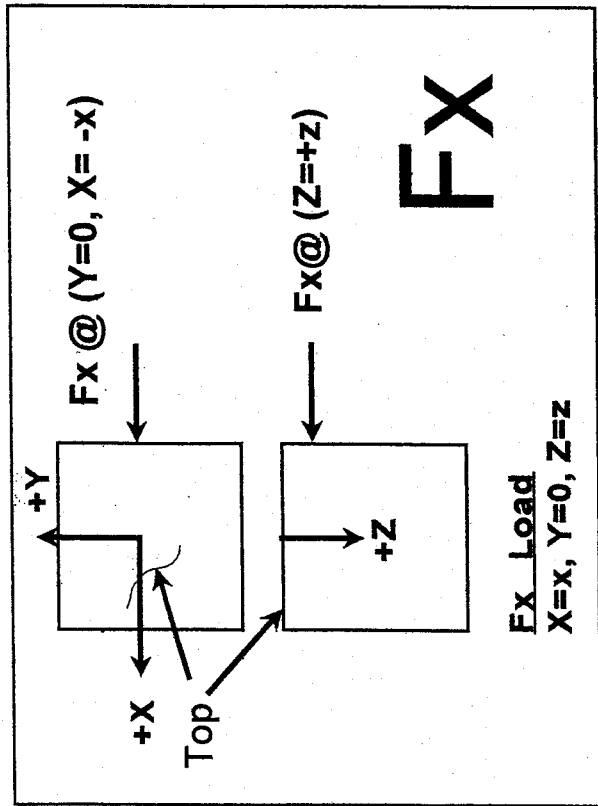
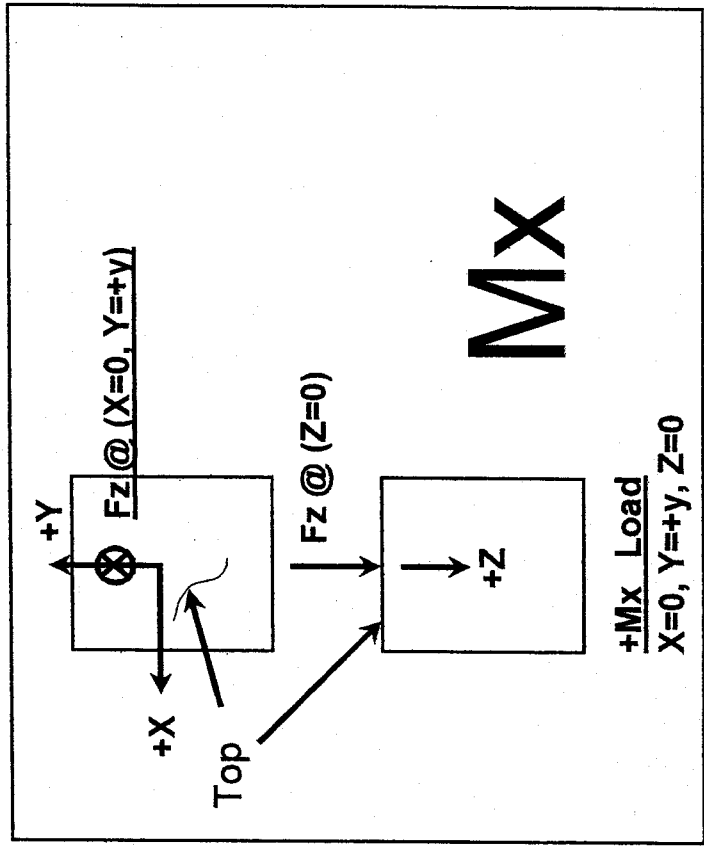
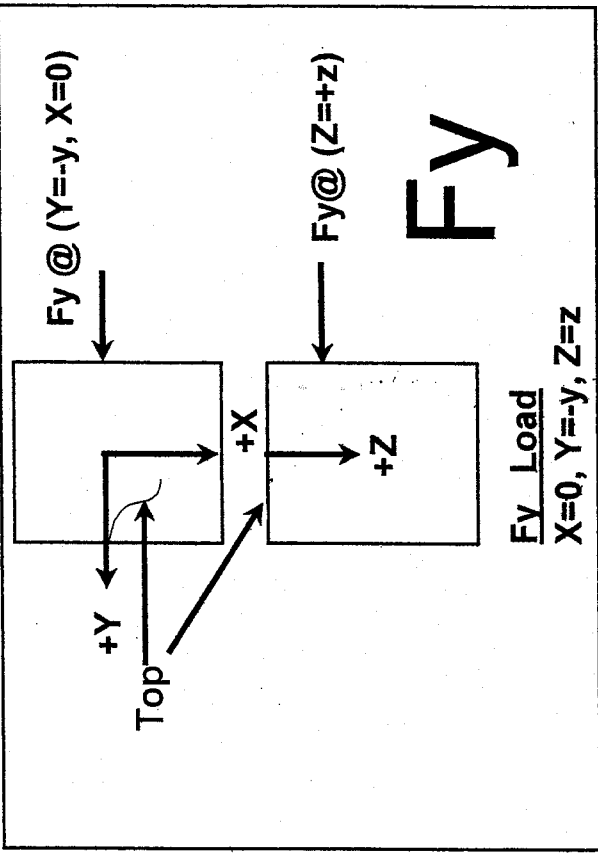

Fig. 2 Application of Fx, Fy, Fz, and Mx Loads

Mx Moment

The Mx moment is generated by applying an Fz load along the Y axis as shown in the lower right figure of Figure 2. The Fz load is applied in the positive Z direction at Y= +y and X=0. Using the “right hand rule” this result in a positive Mx moment.

My Moment

Like the Mx load the My moment is generated by an Fz load but on the X Axis as shown in the top right figure of Figure 3. The Fz load is applied in the positive Z direction at Y=0 and X=-x. Using the “right hand rule” this result in a positive My moment.

Mz Moment

The Mz moment is generated using an Fx load as shown in the top right sketch of Figure 3. The Fx load is applied +z down from the top surface. As mentioned before, the application of the loads are described from the top surface. The actual moment is reference to the z origin located at a moment arm Z3 between the Fx force and the origin.

-Mx Moment

The -Mx moment has the same load conditions described for the Mx moment, except that the force is applied at a -y location.

-My Moment

The -My moment has the same load conditions described for the My moment except that the force is applied at a +x location.

3.2 Main Sensitivity Terms

The first step in the calibration after the loads have been applied is to determine the main sensitivity terms. The equation that defines the relationship between the various terms is:

For forces:

$$F_f(\text{Load}) = V_{f\text{out}} / (V_{f\text{exc}} * S_f * G_f * 1 \times 10^{-6})$$

For moments:

$$M_m(\text{Load}) = V_{m\text{out}} / (V_{m\text{exc}} * S_m * G_m * 1 \times 10^{-6})$$

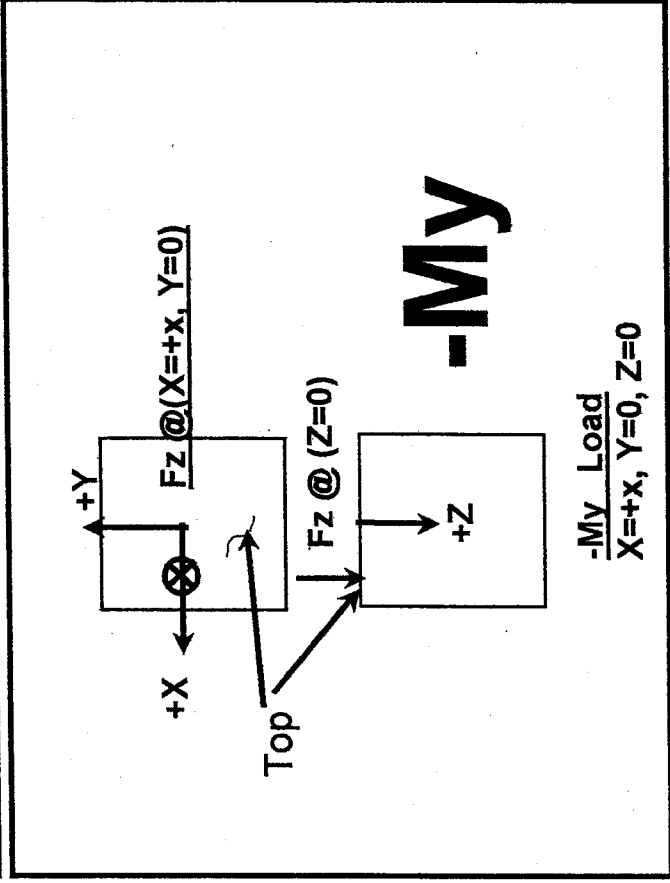
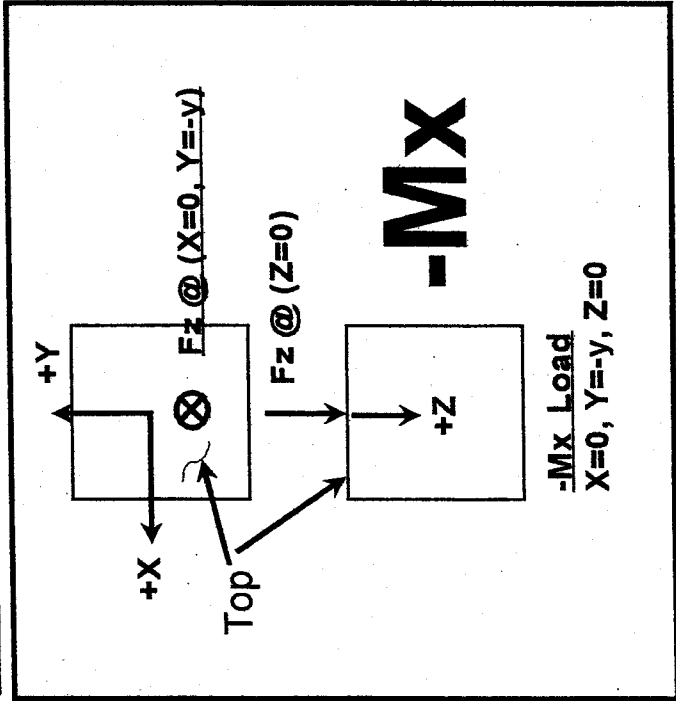
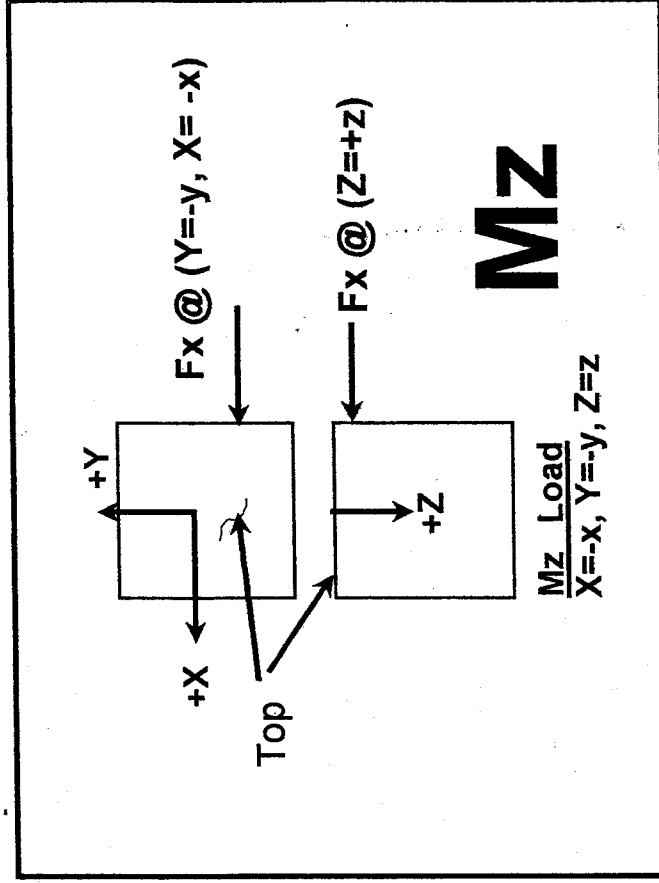
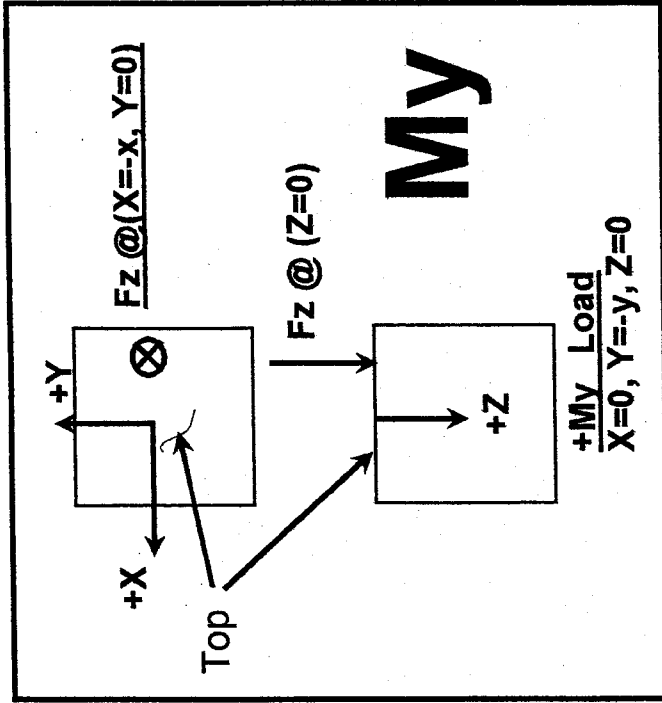

Fig. 3 Application of My, Mz, -Mx, and -My Loads

Where:

F_f = Applied calibrated load (lb or N). In general, the load used to calculate the sensitivity is the rated load for that channel of the transducer.

M_m = Applied moment using a calibrated load applied at a precise distance. In general, the moment used to calculate the sensitivity is the rated moment for that channel of the transducer.

S_f is the sensitivity of F_f in microVolts / V_{exc} -lb or microVolts/ V_{exc} -N

V_{fout} is the output voltage for an F_f load

V_{fexc} is the excitation voltage on the F_f channel

G_f is the gain on the F_f channel.

S_m is the sensitivity of M_m in microVolts / V_{exc} - in-lb or microVolts/ V_{exc} -N-m

V_{mout} is the output voltage for an M_m moment

V_{mexc} is the excitation voltage on the M_m channel

G_m is the gain on the M_m channel.

The sensitivity equations for F_x , F_y , F_z , M_x , M_y , and M_z are:

$$S_{fx} = V_{fxout} / (F_x * V_{fxexc} * G_{fx} * 1 * 10^{-6})$$

$$S_{fy} = V_{fyout} / (F_y * V_{fyexc} * G_{fy} * 1 * 10^{-6})$$

$$S_{fz} = V_{fzout} / (F_z * V_{fzexc} * G_{fz} * 1 * 10^{-6})$$

$$S_{mx} = V_{mxout} / (M_x * V_{mxexc} * G_{mx} * 1 * 10^{-6})$$

$$S_{my} = V_{myout} / (M_y * V_{myexc} * G_{my} * 1 * 10^{-6})$$

$$S_{mz} = V_{mzout} / (M_z * V_{mzexc} * G_{mz} * 1 * 10^{-6})$$

Using the following equation the load can be calculated from the measured output voltage using the following equation for forces:

$$F_f (\text{Load}) = V_{fout} / (V_{fexc} * S_f * G_f * 1 * 10^{-6})$$

Or

The following equation for moments:

$$M_m \text{ (moment)} = V_{\text{mout}} / (V_{\text{mexc}} * S_m * G_m * 1 \times 10^{-6})$$

The main sensitivity terms for the calibrated transducer accompanying this report are provided in the top of the Table B.1 in Appendix B. In general, these can be used with the preceding equations to calculate with great accuracy the forces and moments measured by the transducer.

These terms are individually calculated for each load. When these equations are used, the assumption is made that each axis is independent of the others. That is, there is no cross talk between channels. In general this is a good assumption. These are usually sufficient to predict forces in the direction of load to errors of less than 1 percent of full load and less than 2% cross talk. However, if the user wants to insure the greatest degree of accuracy then they are directed to the section which presents the concept of a Sensitivity matrix and its inverse, the Cross Talk matrix.

Geometric vs. "Effective Origin" or Center

The center of the top surface of the transducer is a convenient reference point for the X, Y, and Z origin. The actual origin, however, is located a distance along the Z-axis which makes the X-Y plane location beneath the top surface of the transducer by a distance z_0 in the positive Z direction. Horizontal loads applied at this z_0 distance will result in zero M_x or M_y moment output. The Z-axis can usually be assumed to lie along the geometric centerline of the transducer. Small deviations x_0 and y_0 from the centerline are also calculated. A vertical F_z force applied at x_0 and y_0 will result in zero M_x and M_y moment outputs. All three (x_0 , y_0 , and z_0) values are presented in Table B.1 of Appendix B.

3.3 Cross-Talk Matrix

As previously mentioned, using the Main Sensitivity terms based on a single load is adequate for most applications. If there is cross-talk due to unusual loading conditions the user can use a "cross-talk" matrix to correct for this effect. Table B.2 of Appendix B presents two matrices, the Sensitivity Matrix ($S(i,j)$) and the "inverse" Sensitivity Matrix ($B(i,j)$) in both English and metric units. The derivation of the Sensitivity Matrix is beyond the scope of this report, but it adjusts the sensitivities to compute "influence coefficients" that correct for any cross talk present.

The Sensitivity Matrix ($S(i,j)$) shows the relationship between the voltage output for each force and any cross talk voltages resulting for the application of the force load. The relevant equations are as follows:

V_F (Output Volt.) =

$$(S_{ij} * F_x * CF_{Fx}) + (S_{ij} * F_y * CF_{Fy}) + (S_{ij} * F_z * CF_{Fz}) + (S_{ij} * M_x * CF_{Mx}) + (S_{ij} * M_y * CF_{My}) + (S_{ij} * M_z * CF_{Mz})$$

(Where CF = Gain * V(excitation) * $1 * 10^{-6}$)

While the sensitivity matrix shows the relationship between the Voltage output and the different parameters, the user is more interested in the relationship between the measured load and the voltage. Thus the inverse of the Sensitivity Matrix or $B(i,j)$ is of more use. This inverse matrix is also presented in Table B.2.

Inverse Sensitivity Matrix ($B_{i,j}$)

	V_{fx}	V_{fy}	V_{fz}	V_{mx}	V_{my}	V_{mz}
F_x	B_{11}	B_{12}	B_{13}	B_{14}	B_{15}	B_{16}
F_y	B_{21}	B_{22}	B_{23}	B_{24}	B_{25}	B_{26}
F_z	B_{31}	B_{32}	B_{33}	B_{34}	B_{35}	B_{36}
M_x	B_{41}	B_{42}	B_{43}	B_{44}	B_{45}	B_{46}
M_y	B_{51}	B_{52}	B_{53}	B_{54}	B_{55}	B_{56}
M_z	B_{61}	B_{62}	B_{63}	B_{64}	B_{65}	B_{66}

The calculation of forces and moments including cross talk terms can be performed using the following equations:

$$F_x =$$

$$(B_{11} * V_{fx} / CF_{fx}) + (B_{12} * V_{fy} / CF_{fy}) + (B_{13} * V_{fz} / CF_{fz}) + (B_{14} * V_{mx} / CF_{mx}) + (B_{15} * V_{my} / CF_{my}) + (B_{16} * V_{mz} / CF_{mz})$$

·
·
·
·

$$M_z =$$

$$(B_{61} * V_{fx} / CF_{fx}) + (B_{62} * V_{fy} / CF_{fy}) + (B_{63} * V_{fz} / CF_{fz}) + (B_{64} * V_{mx} / CF_{mx}) + (B_{65} * V_{my} / CF_{my}) + (B_{66} * V_{mz} / CF_{mz})$$

If the matrix with English units is used then forces and moment will be in pounds and inch-

pounds respectively. If the matrix with metric units is used, then the loads and moments will be in Newtons and Newton-meters.

The user is cautioned to be consistent. If no cross talk correction is needed or used then the Main sensitivities of Table B.1 should be used. If the full cross-talk correction matrix ($B(i,j)$) is used, then they should use all of the terms in the calibration matrix. The two methods should not be mixed.

3.4 Ten Point Loading Tables

Tables C.1 to C.8 contain the F_x , F_y , F_z , M_x , M_y , M_z , $-M_x$, and $-M_y$ calibration data for the transducer. Each table contains the 10 point loading data for the transducer, which includes applying the rated load in 10% increments up to 100% of the rated load, and back down again in 10% increments to zero.

Included are the transducer output from all six channels, gain, excitation voltage, and calibration loads.

4.0 Maintenance

AMTI transducers do not require any maintenance. Theoretically a calibration should not be needed under static conditions as long as the sensor was operated in the elastic region and not damaged or subjected to gross overloads or abuse. Beyond these conditions it is up to the user to establish their own calibration period. These vary from never to once a year.

5.0 WARRANTY

Advanced Mechanical Technology, Inc. (AMTI) warrants all instruments it manufactures to be free from defects in materials and factory workmanship, and agrees to repair or replace any instrument that fails to perform as specified within one year (ten years on Biomechanics Force Platforms) after date of shipment. This warranty shall not apply to any instrument that has been:

- i) repaired, worked on, or altered by persons unauthorized by AMTI in such a manner as to injure, in our sole judgment, the performance, stability, or reliability of the instrument;
- ii) subjected to misuse, negligence, or accident; or

- iii) connected, installed, adjusted, or used otherwise than in accordance with the instructions furnished by us.

At no charge, we will repair at our plant or at our option, replace any of our products found to be defective under this warranty.

This warranty is in lieu of any other warranty, expressed or implied. AMTI reserves the right to make any changes in the design or construction of its instruments at any time, without incurring any obligation to make any change whatever in units previously delivered.

AMTI's sole liabilities, and buyer's sole remedies, under this agreement shall be limited to the purchase price, or at our sole discretion, to the repair or replacement of any instrument that proves, upon examination, to be defective, when returned to our factory, transportation prepaid by the buyer, within one year (ten years on Biomechanics Force Platforms) from the date of original shipment.

Return transportation charges of repaired or replacement instruments under warranty will be prepaid by AMTI.

AMTI is solely a manufacturer and assumes no responsibility of any form for the accuracy of adequacy of any test results, data, or conclusions which may result from the use of its equipment.

The manner in which the equipment is employed and the use to which the data and test results may be put are completely in the hands of the purchaser. AMTI shall in no way be liable for damages consequential of incidental to defects in any of its products.

This warranty constitutes the full understanding between the manufacturer and buyer, and no terms, conditions, understanding, or agreement purporting to modify or vary the terms hereof shall be binding unless hereafter made in writing and signed by an authorized official of AMTI.

Appendix A

MC5 Transducer Description

Transducer Load Specification

Rated maximum Loads

Transducer Model

MC5	-1250	-2500	-5000	-10000
Fx	2670 N(600 lb)	5340 N(1250 lb)	10680 N(2500 lb)	21360 N (5000 lb)
Fy	2670 N(600 lb)	5340 N(1250 lb)	10680 N(2500 lb)	21360 N (5000 lb)
Fz	5340 N(1250 lb)	10680 N(2500 lb)	21360 N(5000 lb)	42720 N (10000 lb)
Mx	203 N-m(1800in-lb)	418 N-m(3700in-lb)	848 N-m(7500in-lb)	1695 N-m(15000in-lb)
My	203 N-m(1800in-lb)	418 N-m(3700in-lb)	848 N-m(7500in-lb)	1695 N-m(15000in-lb)
Mz	136 N-m(1200in-lb)	283 N-m(2500in-lb)	565 N-m(5000in-lb)	1130 N-m(10000in-lb)

Rated loads are individually applied. The moment origin for load calculations can be taken as located at the geometric center of the transducer. The use of simultaneously applied maximum loads may result in a safety factor lower than recommended. Contact the factory for simultaneous loads above one-half the rated loads or for a check on the safety factor for specific loading conditions.

Transducer Torque Guidelines

The ¼-20 threaded holes are in stainless steel inserts. They have sufficient strength to allow taking grade 8 fasteners up to the yield point. The recommended fastener tightening torque depends upon bolt material and lubrication. To prevent possible galling, a thread lubricant should always be used. If you have bolt tightening specifications or guidelines you should follow these. If not, the following are some recommended tightening torques.

Bolt Size - 5/16"-18

- | | |
|---|---------------------|
| 1. Oil Lubricated Grade 8 Bolt | 400 in-lb(3540 N-m) |
| 2. Never Seize Lubricated Grade 8 Bolt | 260 in-lb(2300 N-m) |
| 3. Never Seize Lubricated Austenitic Stainless Bolt | 140 in-lb(1240 N-m) |

If you have any questions please contact AMTI for technical support.

Cable Connector Pinout

<u>Channel</u>	<u>Pin</u>	<u>Pair</u>	<u>Function</u>
Fx	A	Red	+ excitation
	B	Brown	- excitation
	D	Orange	+ output
	C	Black	- output
Fy	E	Red	+ excitation
	F	White	- excitation
	H	Yellow	+ output
	G	Black	- output
Fz	J	Red	+ excitation
	K	Blue	- excitation
	M	Green	+ output
	L	Black	- output
Mx	N	Red	+ excitation
	P	Yellow	- excitation
	S	Blue	+ output
	R	Black	- output
My	T	Red	+ excitation
	U	Green	- excitation
	W	Brown	+ output
	V	Black	- output
Mz	X	Red	+ excitation
	Y	Black	- excitation
	a	White	+ output
	Z	Black	- output

MC5

Force and Torque Transducer



APPLICATIONS

The MC5 force and torque transducer is particularly suitable for applications requiring simultaneous measurement of several forces and moments, or measurement of forces that change direction and position over time. Applications for this transducer include research and development in machining, robotics, ocean engineering and aerospace. It is commonly used in test frames and orthopedic simulators.

DESCRIPTION

The MC5 force and torque transducer measures loads in the range between the capacities of AMTI's popular MC3 and MC8 transducers. It is available with vertical force capacities of 5,600 to 45,000 N (1,250 to 10,000 lbs) and corresponding horizontal force and moment capacities (see table on reverse side). These sensors are available with one to six outputs corresponding to F_x , F_y , F_z , M_x , M_y , and M_z . Models with custom capacities and layouts are available for special applications.

The MC5 has five-inch diameter circular top and bottom surfaces manufactured from high strength aluminum with an anodized finish. An elastomeric O-ring seal protects the strain gages and wiring, and internal sealing of the strain gages further ensures long life and consistent, reliable performance.

CALIBRATION

Each sensor is inspected and tested in AMTI's calibration facility. The calibration procedure involves loading the transducer with ten point uniaxial loads at eight precise locations. These load sets are used by our calibration software to provide the six main sensitivity terms along with calibration matrices for crosstalk compensation.

AMPLIFICATION

The MC5 force and torque sensor incorporates strain gages and a precision element to isolate and measure applied forces and moments. As with most conventional strain gage transducers, bridge excitation and signal amplification are required. AMTI's amplifiers are stable high gain devices which provide excitation and amplification for multiple channels in one convenient package. AMTI's amplifiers process the signals from the transducer and provide outputs suitable for an A/D converter and digital computer or other recording instrument.

CUSTOM

AMTI also offers many other multi-axis transducers to meet your specific needs. Units smaller than 1 inch (2.54 cm) in diameter and large transducers with 200,000 pound vertical capacities are available as standard products. Many of our sensors are waterproof and custom transducers are routinely designed and manufactured. Contact AMTI for additional information.

The following specifications are for estimating purposes. Actual precision calibrations are furnished with each instrument. The manufacturer reserves the right to alter the specifications without notice.

MC5 Series Specifications	1250	2500	5000	10000
Fz Capacity ¹ , lb (N)	1250 (5560)	2500 (11125)	5000 (22250)	10000 (44500)
Fx, Fy Capacity ¹ , lb (N)	625 (2780)	1250 (5340)	2500 (11125)	5000 (22250)
Mz Capacity, in-lb (Nm)	1250 (140)	2500 (283)	5000 (565)	10000 (1130)
Mx, My Capacity ² , in-lb (Nm)	1800 (203)	3700 (418)	7500 (8480)	15000 (1695)
Fz Sensitivity, $\mu\text{V}/[\text{V}\cdot\text{lb}]$ ($\mu\text{V}/[\text{V}\cdot\text{N}]$)	1.0 (0.23)	0.5 (0.11)	0.24 (0.05)	0.12 (0.03)
Fx, Fy Sensitivity $\mu\text{V}/[\text{V}\cdot\text{lb}]$ ($\mu\text{V}/[\text{V}\cdot\text{N}]$)	4.0 (0.91)	2.0 (0.45)	1.0 (0.23)	0.5 (0.11)
Mz Sensitivity $\mu\text{V}/[\text{V}\cdot\text{in}\cdot\text{lb}]$ ($\mu\text{V}/[\text{V}\cdot\text{N}\cdot\text{m}]$)	1.4 (12.4)	0.7 (6.2)	0.4 (3.54)	0.2 (1.77)
Mx, My Sensitivity $\mu\text{V}/[\text{V}\cdot\text{in}\cdot\text{lb}]$ ($\mu\text{V}/[\text{V}\cdot\text{N}\cdot\text{m}]$)	2.3 (20.3)	1.15 (10.18)	0.6 (5.31)	0.3 (2.65)
Fz Stiffness $\times 10^6$ lb/in ($\times 10^7$ N/m)	0.6 (10.5)	1.2 (21.0)	2.5 (43.8)	5.0 (87.6)
Fx, Fy Stiffness ² $\times 10^6$ lb/in ($\times 10^7$ N/m)	0.12 (2.1)	0.25 (4.4)	0.5 (8.8)	1.0 (17.5)
Mz Stiffness $\times 10^6$ in-lb/rad ($\times 10^6$ Nm/rad)	0.5 (0.06)	1.0 (0.11)	2.0 (0.23)	4.0 (0.45)
Mx, My Stiffness $\times 10^6$ in-lb/rad ($\times 10^6$ Nm/rad)	0.75 (0.09)	1.5 (0.17)	2.9 (0.33)	5.5 (0.62)
Lowest Resonant Frequency, Hz; Mx and My	440	625	880	1250

WIRING FOR MC5 SENSOR

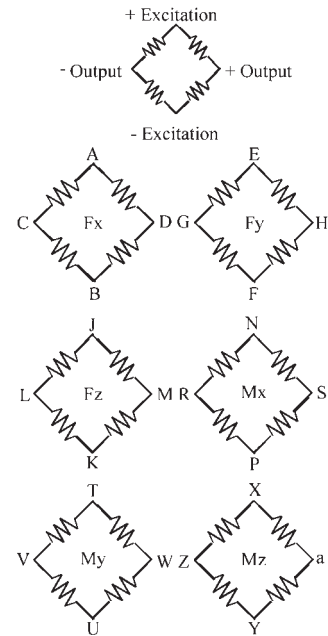

Bridge Fz = 700 ohms
Bridges Fx; Fy; Mx; My; Mz = 350 ohms

Dimensions in inches (cm).

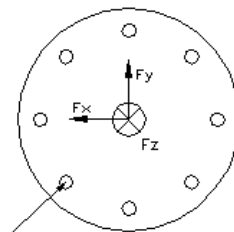

Eight 5/16\"-18 threaded inserts equally spaced on 4.000 (10.16) diam. circle (upper and lower surfaces)

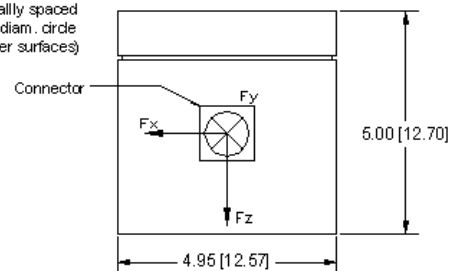

CONNECTOR TYPE

Souriau 851-02E16-26P50-44

¹ The Fx, Fy and Fz capacities can be exceeded by a factor of 3 as long as the Mx, My and Mz capacities are not exceeded.

² Referenced to transducer origin located 2.37 in (6 cm) below top surface.

GENERAL SPECIFICATIONS

Safety Factor: Minimum 50% above capacity

Total Weight: 7 lb (3 kg)

Sensor Top Weight: 3 lb (1.4kg)

Excitation, Recommended : 10V or less

Temperature Range: 0 to 125°F (-17 to 52°C)

Fx, Fy, Fz hysteresis: $\pm 0.2\%$ Full Scale Output

Fx, Fy, Fz non-linearity: $\pm 0.2\%$ Full Scale Output

Crosstalk: Less than 2% on all channels

The normalizing factor for force to moment crosstalk calculations is 40:1 (N to Nm), or 1:1 (lb to in-lb). For example, a 1 Nm moment is equivalent to a 40 N force and produces less than 0.8 N output on a force channel due to crosstalk.

ISO 9001:2000 CERTIFIED



ADVANCED MECHANICAL TECHNOLOGY, INC.

176 WALTHAM STREET WATERTOWN, MA 02472-4800
TEL: (617) 926-6700 • (800) 422-AMTI • FAX: (617) 926-5045
email: sales@amtimail.com • web: www.amti.biz

Appendix B
Sensitivity Terms

Appendix C

Ten Point Loading Tables

A 3.5" Diskette is provided at the end of this section with the calibration tables.