



LOW NOISE DC POWER SUPPLY

LP5393

INSTRUCTION MANUAL

NF Corporation

DA00049390-003

LOW NOISE DC POWER SUPPLY

LP5393

INSTRUCTION MANUAL

———— Preface ————

Thank you for purchasing “**LP5393 Low Noise DC Power Supply**”.

Please read "Safety Precautions" first to ensure the product is used in a correct and safe manner.

●Alert Symbols in this Manual

This manual uses the following alert symbols. The instructions by these alert symbols shall be carefully obeyed to ensure equipment operator's safety, and prevent damage to equipment.

WARNING

Equipment handling could result in death or serious injury. This symbol contains information to avoid such risk.

CAUTION

Equipment handling could result in minor or moderate injury, or property damage. This symbol contains information to avoid such risk.

● This manual consist of following chapters.

If using this product for the first time, start from "1. Outline."

1. Outline

This chapter describes an overview, features and simple operation principle of this product.

2. Preparation Before Use

This chapter describes important preparation before installation and operation.

3. Panels future and Basic Operations

This chapter describes the functions and basic operation of the front and rear panels.

4. Maintenance

This chapter describes the storage and repacking, and how to deal with troubles.

5. Specifications

This chapter describes the specifications (functions and performance).

6. Standard Data

This chapter describes the typical using the standard data as a supplementary.

———— Safety Precautions ————

For safe use, ensure to obey the following warnings and considerations.

We are not responsible for damage resulting from failure to obey these warnings and considerations.

This product is an insulation Class I device (with protective conductor terminal) complying with the JIS and IEC standards.

- **Ensure you obey the instructions in this instruction manual.**

This instruction manual contains instructions for the safe operation and use of this product.

Before using the product, please read this manual first.

All the warning items contained in this instruction manual are intended for preventing risks that may lead to serious accidents. Ensure to obey them.

- **Ensure to ground:**

To prevent electrical shock accidents, connect it to an earth ground so that ground resistance is 100 Ω or lower.

This product is automatically grounded by connecting a 3-pin power plug to a power outlet with a protective ground contact.

This product does not include a 3 pin to 2 pin adapter. To use a 3 pin to 2 pin adapter, be sure to connect the ground wire of the adapter to the ground terminal near the outlet.

- **Check the power input voltage.**

This product operates at a power supply voltage specified in "Grounding and Power Connections" of this instruction manual.

This product has a power supply voltage select function. Before connecting to the outlet, check that the set power input voltage matches the voltage of the outlet.

- **Observe the rating of the fuse.**

Failure to do so may cause fire or other accidents. Use a fuse with the rating specified in "Grounding and Power Connection" of this instruction manual.

Before replacing the fuse, be sure to disconnect the power plug from the outlet.

- **If you notice anything strange.**

If you notice smoke or a strange odor or sound being emitted from this product, promptly turn off the power switch and disconnect the power cord and output cable.

Should you encounter any anomaly like above, immediately contact us or our agent. Never use it until the repair is completed.

- **Do not use in a gaseous atmosphere.**

This may pose a risk of explosion or other.

Safety Precautions

- Do not remove the cover.

This product has high-voltage portions inside. Never remove the cover.

When inspection into the inside of the product is needed, never allow anybody to touch the innards except our certified service engineers.

- Do not modify this product.

Never modify the product. Modification to the product may pose a new risk. We may refuse the repair of a modified product at fault.

- Do not expose this product to water.

When this product is used in wet condition, it may cause an electric shock and a fire. If this product is exposed to water, cut the power at the distribution board immediately, and contact us or our agent.

- If lightning occurs, power off this product and cut the power at the distribution board.

A lightning may cause electric shock, a fire and a failure.

- Safety symbols

The following shows the general definitions of the safety symbols and used on the product main unit and in the instruction manual.



Refer to the instruction manual

This notifies the user of potential hazard and indicates that he/she must refer to the instruction manual.



Electric shock hazard

This indicates that an electric shock may occur under the specific conditions.



Warning Symbol

This contains information to avoid risks in equipment handling that could result in loss of life or bodily injury (e.g. electric shock).



Caution Symbol

This contains information to avoid damage to the equipment in equipment handling.

- Other Symbols



Indicates the ON position of the power switch.



Indicates the OFF position of the power switch.



Indicates that the external conductor of the connector is connected to the case.



Indicates that the external conductor of the connector is connected to the output GND.

Safety Precautions

- Request about disposal

This product does not include batteries and is designed in accordance with the RoHS Directive (EU).

Dispose of the product in accordance with the laws and regulations of the area where you use it.

Contents

	Page
Preface	i
Safety Precautions	ii
1. Outline	1-1
1.1 Overview	1-1
1.2 Features	1-1
1.3 Operating Principle	1-1
2. Preparation Before Use	2-1
2.1 Checking Before Use	2-1
2.2 Installation	2-3
2.3 Grounding and Power Connections	2-7
2.4 Simplified Operation Check	2-9
2.5 Inspection	2-9
3. Panel Futures and Basic Operations	3-1
3.1 Panel Component Names and Functions	3-1
3.1.1 LP5393 Panel Component Names and Functions	3-1
3.1.2 BNC Adapter Panel Component Names and Functions	3-4
3.1.3 Binding Post Adapter Panel Component Names and Functions	3-5
3.2 Output Terminals and GND	3-6
3.3 Optional Cable Output Terminals and GND	3-7
3.4 Output Connection	3-9
3.4.1 Connecting with SA-600 Series	3-10
3.4.2 Connecting with SA-200 and SA-400 Series except for SA-230F5	3-11
3.4.3 Connecting with SA-230F5	3-12
3.4.4 Connecting with Evaluation Kit PA-001-2179	3-13
3.4.5 Connecting with BNC Adapter	3-14
3.4.6 Connecting with Binding Post Adapter	3-15
3.5 Turning On Power and Warm-up Time	3-16
3.6 Protection Functions and Display	3-16
3.6.1 Overcurrent Protection	3-16
3.6.2 Overheat Protection	3-16
4. Maintenance	4-1
4.1 Preface	4-1
4.2 Daily Maintenance	4-1
4.3 Storage, Repacking, and Transportation	4-1
4.4 Troubleshooting	4-2
5. Specifications	5-1
5.1 LP5393 Specifications	5-1
5.1.1 Type	5-1

5.1.2	Output Characteristics.....	5-1
5.1.3	Input Characteristics	5-2
5.1.4	Others	5-2
5.2	BNC Adapter Specifications.....	5-4
5.2.1	Rating	5-4
5.2.2	Environmental Conditions	5-4
5.2.3	Dimensions and Weight	5-4
5.2.4	Standard	5-4
5.2.5	Block Diagram.....	5-4
5.3	Binding Post Adapter Specifications	5-5
5.3.1	Rating	5-5
5.3.2	Environmental Conditions	5-5
5.3.3	Dimensions and Weight	5-5
5.3.4	Standard	5-5
5.3.5	Block Diagram.....	5-5
5.4	External Dimensions.....	5-6
5.4.1	LP5393 External Dimensions	5-6
5.4.2	BNC Adapter External Dimensions.....	5-7
5.4.3	Binding Post Adapter External Dimensions.....	5-8
6.	Standard Data.....	6-1
6.1	Standard Data.....	6-1
6.2	Output Noise Voltage Waveforms	6-1
6.3	Output Noise Voltage Density Frequency Characteristic	6-2
6.4	Long Time Drift Characteristic	6-2
6.5	Temperature Drift	6-3

Warranty

Figures and Tables

	Page
Figure 1-1 Block Diagram.....	1-2
Figure 2-1 Rack Mount Kit (EIA, for 4 Units) External View	2-4
Figure 2-2 Rack Mount Kit (JIS, for 4 Units) External View	2-5
Figure 2-3 Fuse Holder External View.....	2-8
Figure 3-1 P5393 Front and Rear Panel Views	3-3
Figure 3-2 BNC Adapter Front and Rear Panel Views.....	3-4
Figure 3-3 Binding Post Adapter Front and Rear Panel Views	3-5
Figure 3-4 Connection between Output Terminals and GND	3-6
Figure 3-5 Connections between Optional Cable Terminals and Output GND	3-7
Figure 3-6 Connecting with SA-600 Series.....	3-10
Figure 3-7 Connecting with SA-200 and SA-400 Series except for SA-230F5	3-11
Figure 3-8 Connecting with SA-230F5	3-12
Figure 3-9 Connecting with Evaluation Kit PA-001-2179	3-13
Figure 3-10 Connecting with BNC Adapter	3-14
Figure 3-11 Connecting with Binding Post Adapter	3-15
Figure 5-1 HR10-7R-4S (73) Pin Numbers and Connections	5-1
Figure 5-2 Temperature and Humidity Range Explanatory Graph	5-3
Figure 5-3 BNC Adapter Block Diagram.....	5-4
Figure 5-4 Binding Post Adapter Block Diagram	5-5
Figure 5-5 LP5393 External Dimensions.....	5-6
Figure 5-6 BNC Adapter External Dimensions	5-7
Figure 5-7 Binding Post Adapter External Dimensions	5-8
Figure 6-1 Output Noise Voltage Waveform (+15 V Output, Rated Load, Bandwidth 10 Hz to 20MHz)	6-1
Figure 6-2 Output Noise Voltage Waveform (-15V Output, Rated Load, Bandwidth 10 Hz to 20MHz)	6-1
Figure 6-3 Output Noise Voltage Density Frequency Characteristic (+15 V Output, Rated Voltage)	6-2
Figure 6-4 Long Time Drift Characteristic	6-2
Figure 6-5 Temperature Drift (Rated Load)	6-3
Table 2-1 Configuration List.....	2-1
Table 4-1 Actions When Problems Occur	4-2

1. Outline

1.1	Overview.....	1-1
1.2	Features.....	1-1
1.3	Operating Principle	1-1

1.1 Overview

"LP5393" is a low noise DC power supply that has achieved an output noise of 10 μVrms or lower (typical) (10 Hz to 20 MHz bandwidth) and output voltage stability of ± 20 ppm/ $^{\circ}\text{C}$ (typical).

The output voltage can be adjusted in the range of ± 12 V to ± 15 V using the adjuster on the front panel. The maximum output current is ± 0.1 A.

1.2 Features

- a) The output noise is 10 μVrms or lower (typical).
- b) The output voltage stability is ± 20 ppm/ $^{\circ}\text{C}$ (typical).
- c) The output terminals are HR10-7R-4S (73) which is the same model as that of SA-600 Series.
- d) The output can be turned ON and OFF on the front panel.
- e) The output voltage can be adjusted in the range of ± 12 V to ± 15 V using the adjuster on the front panel.
- f) The output is insulated from the chassis (± 42 Vpk) to eliminate the current noise caused by the GND loop.
- g) The power input voltage can be selected from AC 100, 120, 220 and 240 V using the VOLTAGE SELECTOR switch on the rear panel.
- h) This is an ideal power supply for the Low Noise Amplifier SA Series.

1.3 Operating Principle

The power supply voltage is insulated, reduced, and rectified by a transformer, and then converted to a stable DC voltage by a series regulator. The output voltage can be adjusted in the range of ± 12 V to ± 15 V using the adjuster on the front panel.

The output stabilized by the regulator can be switched ON and OFF using the output selector switch on the front panel.

The output GND is connected with the chassis GND with 10 M Ω .

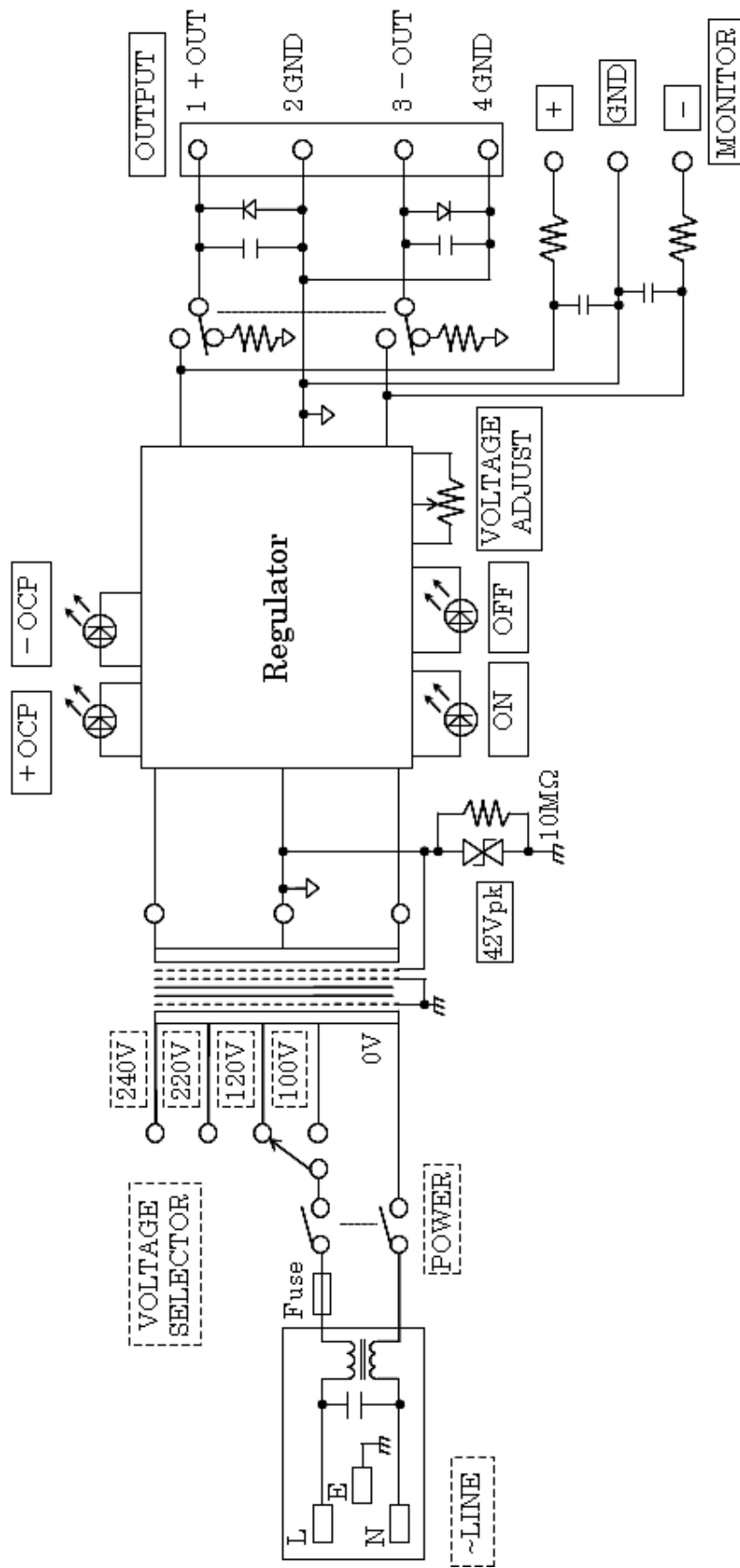

Figure 1-1 Block Diagram

2. Preparation Before Use

2.1	Checking Before Use	2-1
2.2	Installation.....	2-3
2.3	Grounding and Power Connections	2-7
2.4	Simplified Operation Check.....	2-9
2.5	Inspection	2-9

2.1 Checking Before Use

■ Safety Check

To ensure the safety of the user, be sure to read the following sections of the instruction manual first.

- "Safety Precautions" (at the beginning of this instruction manual)
- "2.3 Grounding and Power Connection"

■ Check the Appearance and Accessories

If you notice something out of the order on the outside of the packing box (such as a scratch or dent), closely check that the product is not affected when you remove it from the box.

When you have removed the contents from the packing box, check them.

If you find a scratch on the product or an accessory is missing, report the problem to Us or our agent.

● Appearance Check

Check that there is no scratch or dent on the panel surfaces, connectors, etc.

● Product Configuration Check

The following shows the product configuration. Check that the quantities are correct and there is no scratch.

Table 2-1 Configuration List

● LP5393 Main unit	1
● Accessories	
Instruction manual	1
Power cord set (3 pole, 2 m)	1
Fuse (100 V/120 V: 0.315 A or 220 V/240 V: 0.125 A) (Time-Lag, ϕ 5.2×20 mm) ..	1

⚠ WARNING

This product has high-voltage portions inside. Never remove the cover.

When inspection into the inside of the product is needed, never allow anybody to touch the innards except our certified service engineers.

- Options

There are the optional output cables, rack mount kits, and adapters listed below. The options are sold separately. Purchase and use them to suit the composition.

PA-001-2372: Output Cable A (for SA-600 Series, 2 m)

PA-001-2373: Output Cable B (for SA-200 and SA-400 Series except for SA-230F5, 2 m)

PA-001-2374: Output Cable C (for SA-230F5, 2 m)

PA-001-2590: BNC Adapter

PA-001-2591: Binding Post Adapter

PA-001-2642: Rack Mount Kit (EIA, for 4 units)

PA-001-2643: Rack Mount Kit (JIS, for 4 units)

2.2 Installation

■ Installation Position

Do not install the product so that the rear panel is at the bottom.

Install it so that all of the four rubber feet on the bottom sit on the flat surface of a table, etc.

■ Rack Mount

This product can be mounted in a 19-inch IEC rack, EIA standard rack, or JIS standard rack by attaching the rack mount kit (sold separately). Rack mount kits for a JIS standard rack and EIA standard rack are available.

First, attach the rack mount kit as shown in Figure 2-1 Rack Mount Kit (EIA, for 4 Units) External View and Figure 2-2 Rack Mount Kit (JIS, for 4 Units) External View, and then mount the product to a rack.

Pay attention to the following points when mounting the product in a rack.

- Be sure to install a rail, etc. in the rack to support this product.
- If this product is mounted in a sealed rack, the temperature will increase resulting in a malfunction.

Provide ventilation holes in the rack, or use a fan to forcibly cool the inside of the rack.

- Avoid dusty and humid locations.

The insulation resistance may decrease and the leakage current will increase causing deterioration of performance.

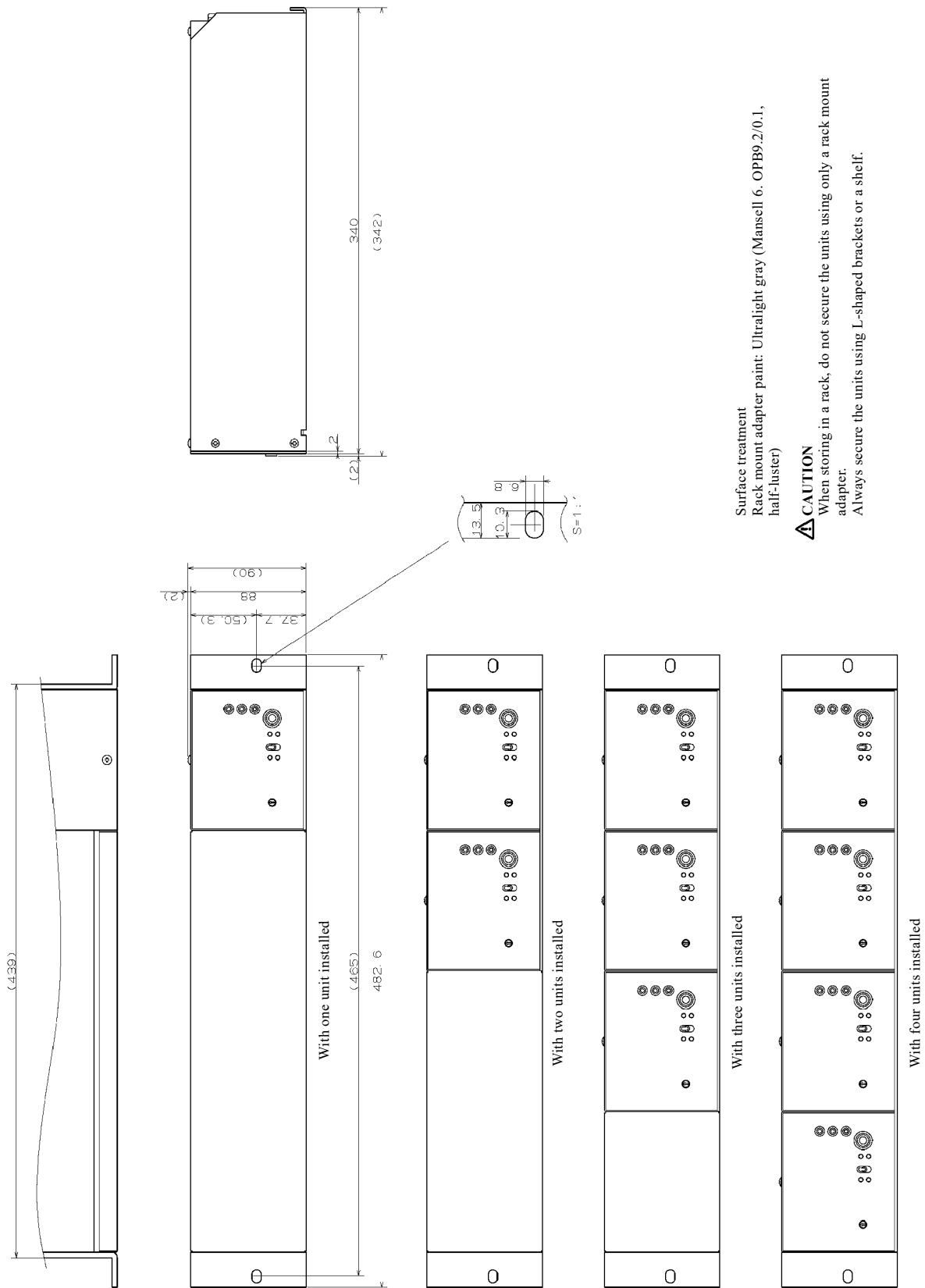

Figure 2-1 Rack Mount Kit (EIA, for 4 Units) External View

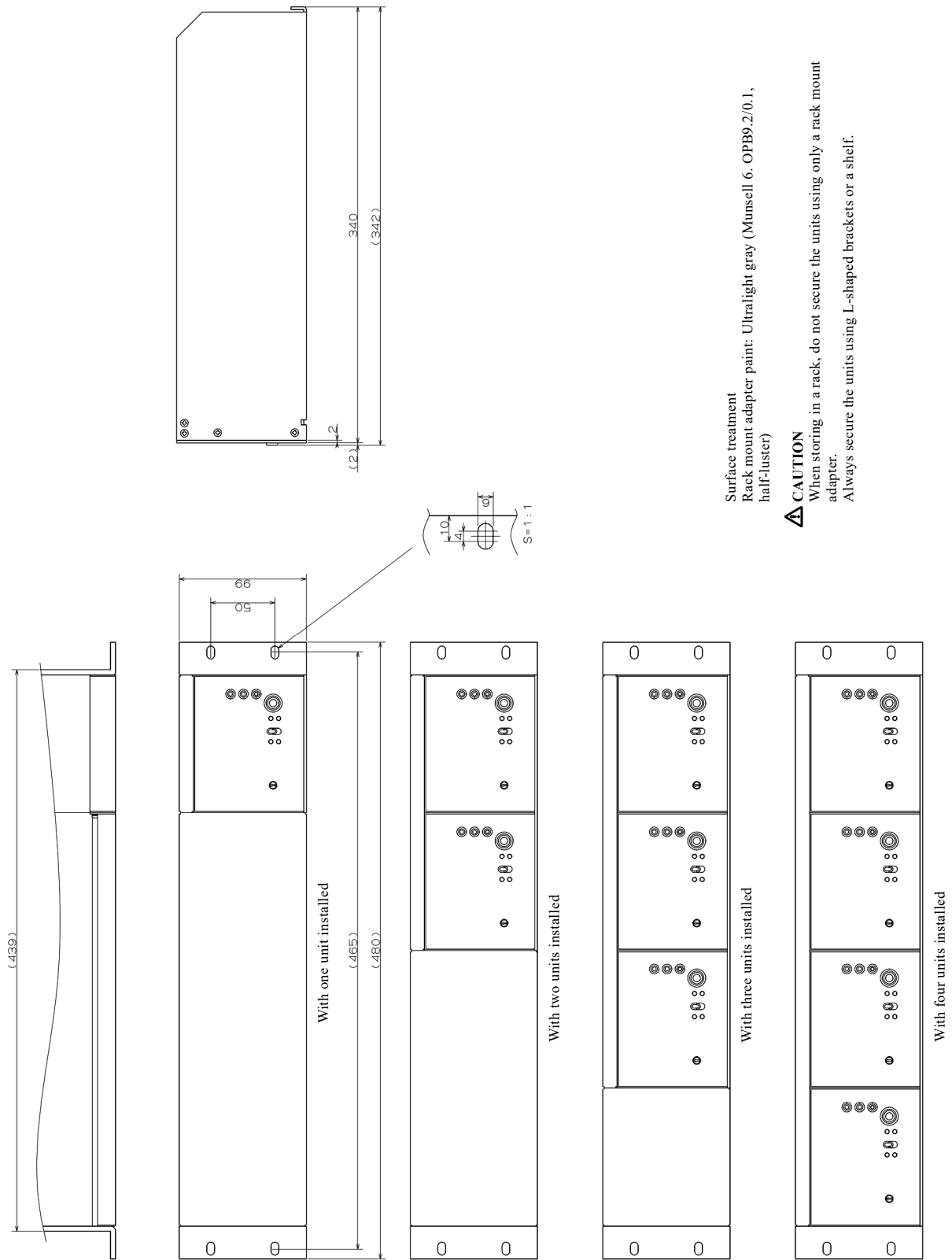

Figure 2-2 Rack Mount Kit (JIS, for 4 Units) External View

■ Conditions for Installation Location

- The installation location shall meet the following temperature and humidity conditions.

Operating conditions: 0 to 50 °C, 5 to 85 %RH

Storage conditions: -10 to 60 °C, 5 to 95 %RH

However, use the product with non-condensation. For the absolute humidity range, refer to the specifications.

- Use the product indoors, at altitude up to 2000 m.

- Do not install the product in the following locations:

- Location where flammable gases may be present

There is danger of explosion. Never install or use it at such a location.

- Outdoors or location exposed to direct sunlight, or near a fire or heat source

The expected performance of this product may not be exhibited, or a malfunction may result.

- Location where corrosive gases, water vapor, or dust may be present, or humid location

This product may become corroded, or a malfunction may result.

- Near an electromagnetic field source, high-voltage device, or power line

Noise may increase.

- Location where there is a lot of vibration

Noise may increase or a malfunction may result.

2.3 Grounding and Power Connections

- Ensure to ground

⚠ WARNING

To prevent electrical shock accidents, connect it to an earth ground so that ground resistance is 100 Ω or lower.

This product is automatically grounded by connecting a 3-pin power plug to a power outlet with a protective ground contact.

This product does not include a 3 pin to 2 pin adapter. To use a 3 pin to 2 pin adapter, be sure to connect the ground wire of the adapter to the ground terminal near the outlet.

- The following shows the power input conditions for this product.

Voltage range: AC 100, 120, 220 or 240 V \pm 10 %, but 250 V or lower

Frequency range: 50/60 Hz \pm 2 Hz

Power consumption: 25 VA or lower

Overvoltage category: II

This product has a power input voltage selector switch on the rear panel. Check that the voltage of the outlet matches the voltage set with the power input voltage selector switch. To select the power input voltage, disconnect the power cord and then turn the selector switch with a Coin-driver slowly.

- Perform the following steps to connect to the outlet.

- 1) Check that the outlet voltage to be connected is within the voltage range of this product.
- 2) Turn off the power switch of this product.
- 3) Insert the power cord into the inlet on the rear panel of this product.
- 4) Insert the plug of the power cord into the outlet with a protective ground contact.

- The power cord can be used to disconnect this product from the outlet in case of an emergency.

⚠ WARNING

To ensure that the power cord can be disconnected from the inlet on LP5393, allow sufficient space around the inlet, or to ensure that the power plug can be disconnected from the outlet, use an outlet in an easily accessible location and allow sufficient space around the outlet.

- Observe the rating of the power fuse.

The following shows the rating of the power fuse of this product.

100 V/120 V: time-Lag 0.315 A

220 V/240 V: time-Lag 0.125 A

The rated voltage for both is 250 V/ $\phi 5.2 \times 20$ mm.

To replace the fuse, disconnect the power cord, and then turn the fuse holder on the rear panel left with a screwdriver and pull it out. Replace the old fuse with a new one, insert the fuse holder, and turn it right with a screwdriver to lock it.

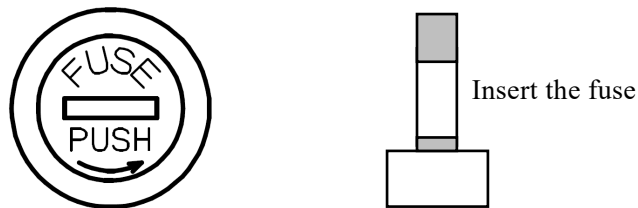

Figure 2-3 Fuse Holder External View

⚠ WARNING

There is risk of fire or other accidents. Use a fuse of the same rating when replacing the old fuse.

Before replacing the fuse, be sure to disconnect the power plug from the outlet.

⚠ CAUTION

Set the power input voltage selector switch to the position where it clicks to prevent the switch from being in a half-way position.

Check the power input voltage selector switch setting and then connect the product to the outlet.

Check that the voltage of the outlet is within the specified power input voltage and then connect to the outlet. Failure to do so may damage this product.

2.4 Simplified Operation Check

Turn on this product and check that the OUTPUT OFF LED turns on and the +OCP LED and -OCP LED are off.

Furthermore, turn on the OUTPUT without load. Check that the OUTPUT ON LED turns on and + OCP LED and -OCP LED are off.

Connect the voltage meter to the output monitor terminal and turn the VOLTAGE ADJUST dial fully clockwise, and check that the output voltage is within $\pm 15 \pm 0.15$ V. Likewise, turn the VOLTAGE ADJUST dial fully counter clockwise and check that the output voltage is within $\pm 12 \pm 0.12$ V.

The simplified operation check is now complete.

WARNING

If you notice smoke or a strange odor or sound being emitted from this device

Promptly disconnect the power cord from the outlet and put a notice on the product stating that it cannot be used until repairs are completed.

2.5 Inspection

The periodic inspection interval varies depending on the operating environment and operating frequency, but it is recommended to perform periodic inspection for this product at least once every year.

If inspection is required, contact us or our agent.

Charges apply for inspection, calibration, and adjustment services.

3. Panel Futures and Basic Operations

3.1	Panel Component Names and Functions	3-1
3.1.1	LP5393 Panel Component Names and Functions	3-1
3.1.2	BNC Adapter Panel Component Names and Functions	3-4
3.1.3	Binding Post Adapter Panel Component Names and Functions	3-5
3.2	Output Terminals and GND	3-6
3.3	Optional Cable Output Terminals and GND....	3-7
3.4	Output Connection	3-9
3.4.1	Connecting with SA-600 Series	3-10
3.4.2	Connecting with SA-200 and SA-400 Series except for SA-230F5	3-11
3.4.3	Connecting with SA-230F5	3-12
3.4.4	Connecting with Evaluation Kit PA-001-2179	3-13
3.4.5	Connecting with BNC Adapter	3-14
3.4.6	Connecting with Binding Post Adapter	3-15
3.5	Turning On Power and Warm-up Time	3-16
3.6	Protection Functions and Display	3-16
3.6.1	Overcurrent Protection	3-16
3.6.2	Overheat Protection	3-16

3.1 Panel Component Names and Functions

3.1.1 LP5393 Panel Component Names and Functions

See Figure 3-1 LP5393 Front and Rear Panel Views

■ Front Panel

① VOLTAGE ADJUST

This adjuster allows you to adjust the output voltage. It can be set to ± 15 V by turning the adjuster all the way to the right, and to ± 12 V by turning the adjuster all the way to the left.

Using a screwdriver whose tip does not match or applying excessive force during adjustment may cause damage.

② OUTPUT ON/OFF LED

These LEDs indicate the ON/OFF status of the output voltage. Furthermore, if the overheat protection function is activated, the OFF LED flashes.

③ OUTPUT Switch

This switch allows you to switch between ON and OFF. Flip the switch up to turn on the output, and flip it down to turn off the output.

Applying excessive force to the switch may cause damage.

④ +OCP LED, -OCP LED

When the output current is over approximately 150 mA or more, +OCP LED and -OCP LED turn on with working positive or negative output over current protection function respectively.

⑤ Output Connector

This is an output terminal. The connector is HR10-7R-4S (73). Applying excessive force to the connector may cause damage.

⑥ Monitor Terminals

These are output voltage monitor terminals (mating pin diameter 2 mm). The output resistance of the monitor terminals is approximately 1 k Ω . Therefore, it is recommended to monitor the output voltage with, for example, a multimeter with an input resistance of 1 M Ω or more (error 0.1 % with an input resistance of 1 M Ω and 0.01 % with 10 M Ω).

Applying excessive force to the terminal may cause damage.

■ Rear Panel

⑦ POWER Switch

This switch allows you to turn on and off the power. Set the switch to the “I” position to turn on the power, and set it to the “O” position to turn off the power.

Applying excessive force to the switch may cause damage.

⑧ Inlet

This is a connector to the outlet. Apply the power input voltage set with VOLTAGE SELECTOR. Furthermore, one of the pins of the three-prong power connector serves as a protective grounding terminal so is sure to connect it to an earth ground.

⑨ Fuse Holder

The fuse holder holds the fuse in place.

Strictly observe the rating of the fuse (refer to 2.3). Before replacing the fuse, be sure to disconnect the power cord.

⑩ VOLTAGE SELECTOR

This switch allows you to switch the power input voltage. Switch the power input voltage to the one you want to use with a Coin-driver.

Set the switch to the position where it clicks to prevent it from being in a half-way position.

Applying excessive force to the switch may cause damage.

3.1 LP5393 Panel Component Names and Functions

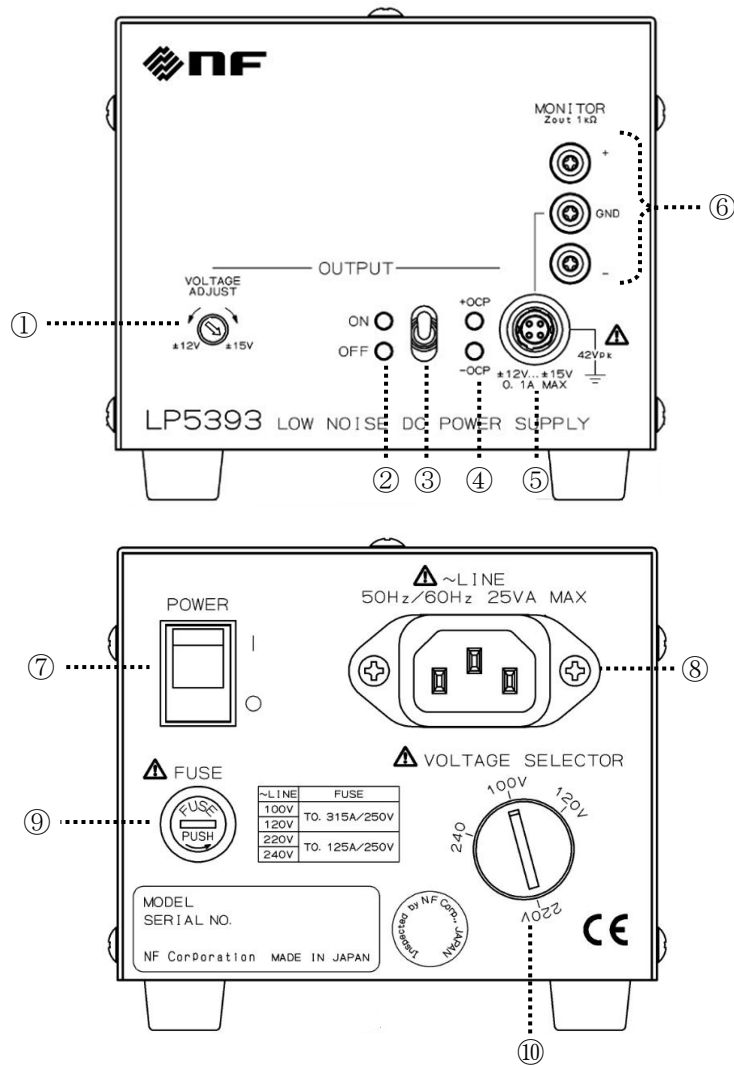

Figure 3-1 P5393 Front and Rear Panel Views

3.1.2 BNC Adapter Panel Component Names and Functions

Optional BNC adapter (PA-001-2590) for converting LOW NOISE DC POWER SUPPLY LP series output to BNC connector output is available.

See Figure 3-2 BNC Adapter Front and Rear Panel Views

■ Front Panel

① DC INPUT

This is an input terminal. DC INPUT is connected to the LP series supply power output with optional output cable A. The connector is HR10-7R-4P (73). Applying excessive force to the connector may cause damage.

② +OUTPUT

This is a positive output terminal. The connector is a BNC connector. Applying excessive force to the connector may cause damage. GND of the BNC connector is connected to the chassis.

③ -OUTPUT

This is a negative output terminal. The connector is a BNC connector. Applying excessive force to the connector may cause damage. GND of the BNC connector is connected to the chassis.

■ Rear Panel

④ (Holes for BNC adapter mounts)

To remove the bottom plate and mount this adapter directly to the chassis, etc., use these screw holes (M3) (the length of the screws should be 5 mm or lower).

Note that if the bottom plate is removed, the adapter and the chassis to which it is mounted are electrically connected. The bottom plate is mounted to the adapter using 8 mm plastic screws (M3).

⑤ (Mounting holes)

These holes (M3) are used to mount this adapter to the chassis, etc. with the bottom plate mounted to it. This adapter can be mounted to the chassis while they are electrically insulated.

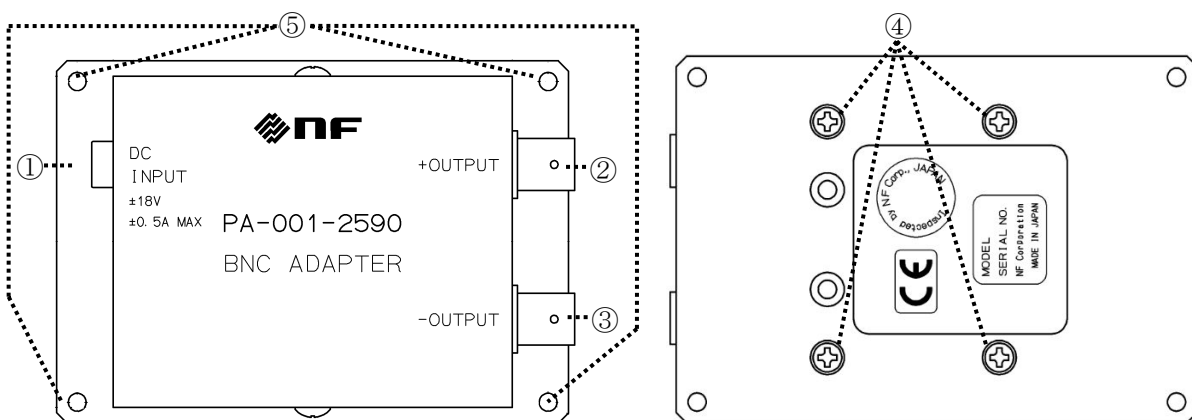

Figure 3-2 BNC Adapter Front and Rear Panel Views

3.1.3 Binding Post Adapter Panel Component Names and Functions

Optional binding post adapter (PA-001-2591) for converting LOW NOISE DC POWER SUPPLY LP series output to binding post output is available.

See Figure 3-3 Binding Post Adapter Front and Rear Panel Views.

■ Front Panel

① DC INPUT

This is an input terminal. DC INPUT is connected to the LP series power supply output with optional output cable A. The connector is HR10-7R-4P (73). Applying excessive force to the connector may cause damage.

② +OUTPUT

This is a positive output terminal. The connector is a binding post. Applying excessive force to the connector may cause damage.

③ GND

This is an output GND terminal. The connector is a binding post. Applying excessive force to the connector may cause damage. The output GND terminal is connected to the chassis.

④ -OUTPUT

This is a negative output terminal. The connector is a binding post. Applying excessive force to the connector may cause damage.

■ Rear Panel

⑤ (Holes for binding post adapter mounts)

To remove the bottom plate and mount this adapter directly to the chassis, etc., use these screw holes (M3) (the length of the screws should be 5 mm or lower).

Note that if the bottom plate is removed, LP5394 and the mounted adapter are electrically connected. The bottom plate is mounted to LP5394 using 8 mm plastic screws (M3).

⑥ (Mounting holes)

These holes (M3) are used to mount this adapter to the chassis, etc. with the bottom plate mounted to it. This adapter can be mounted to the chassis while they are electrically insulated.

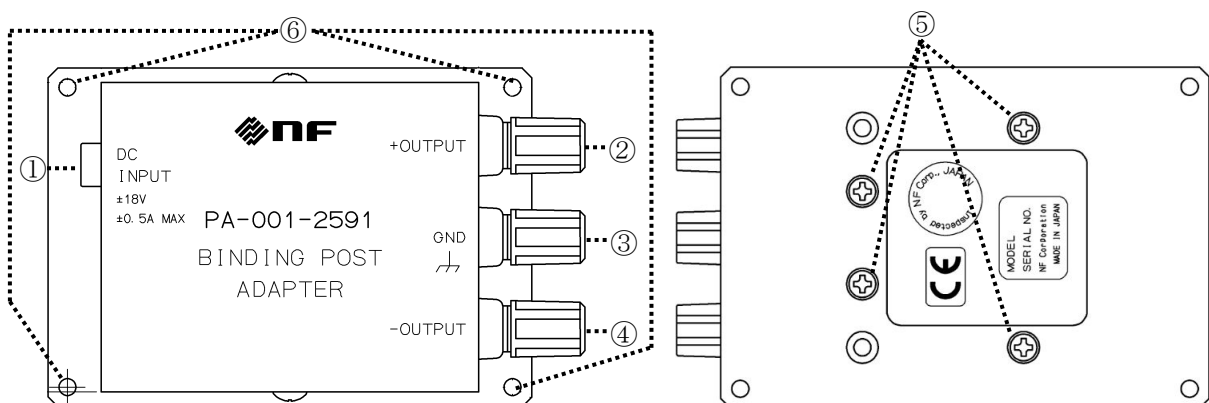

Figure 3-3 Binding Post Adapter Front and Rear Panel Views

3.2 Output Terminals and GND

The following figure shows the internal connections for the output terminals. GND of the output terminal (output GND) is connected with the chassis GND with $10\text{ M}\Omega$. When output is off, the both of $\pm\text{OUT}$ terminals are connected to output GND with $1\text{ k}\Omega$ to discharge the capacitor. The withstanding voltage between output GND and chassis GND is 42 Vpk (DC + ACpeak).

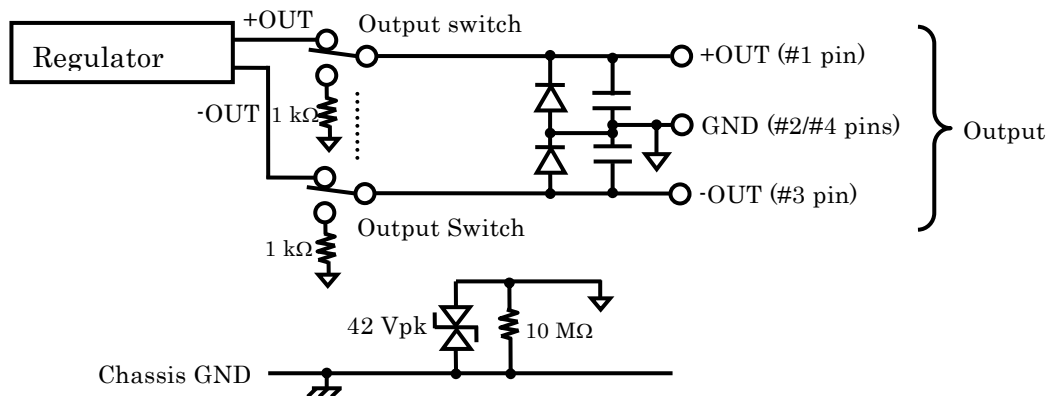

Figure 3-4 Connection between Output Terminals and GND

Use a HR10-7P-4P (73) connector to be connected to the output terminals and insert it to the point where it clicks. To remove the connector, hold the outer body of the connector and pull it out straight. There is a lock release mechanism on the outer body of the connector. Pulling any other part may cause damage to the cable.

The outer body of the connector for the output terminal is connected to output GND.

⚠ WARNING

To prevent electric shock, do not apply a voltage greater than 42 Vpk (DC + ACpeak) between GND of the output terminal and chassis GND.

If the voltage exceeds this value, the internal voltage limiting element works to suppress the voltage, but if the applied voltage (energy) is large, the voltage limiting element of this product may be damaged by heat.

⚠ CAUTION

Do not apply voltage between output terminals from outside. This product may be damaged.

3.3 Optional Cable Output Terminals and GND

The following shows the connections between the optional cable output terminals and output GND. The left side is connected to the output terminal side of this product.

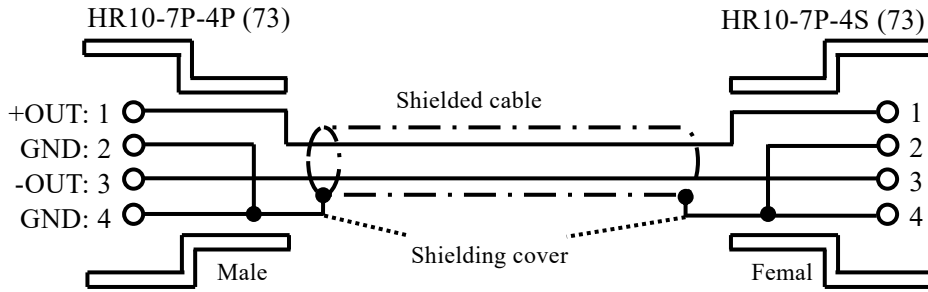

(a) Output Cable A (for SA-600 Series)

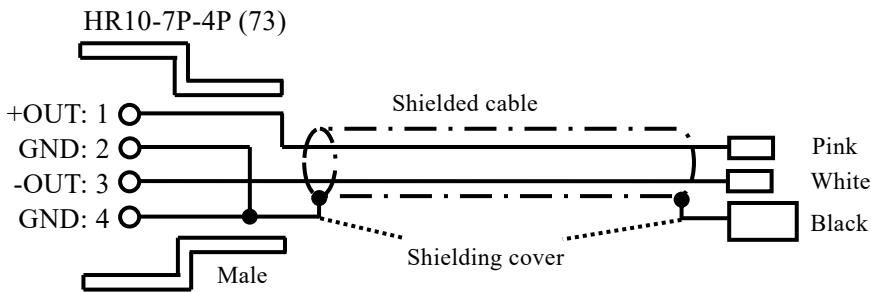

(b) Output Cable B (for SA-200 and SA-400 Series except for SA-230F5)

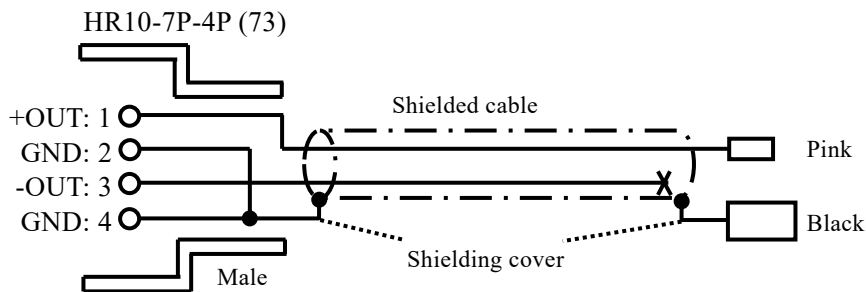

(c) Output Cable C (for SA-230F5)

Figure 3-5 Connections between Optional Cable Terminals and Output GND

HR10-7P-4P (73) is used as the connector for all optional cables to be connected to this product. The outer body of the connector is connected to the output GND of this product.

HR10-7P-4S (73) is used as the connector for output cable A (for SA-600 series) to be connected to the preamplifier. The outer body of the connector is connected to the chassis of the preamplifier. Output GND and the preamplifier chassis have the same electric potential.

⚠ WARNING

To prevent electric shock, do not apply a voltage greater than 42 Vpk (DC + ACpeak) between GND of the output terminal and chassis GND.

If the voltage exceeds this value, the internal voltage limiting element of this product works to suppress the voltage, but if the applied voltage (energy) is large, the voltage limiting element of this product may be damaged by heat.

3.4 Output Connection

Shielding of output cables and the connection and installation method are important to supply low noise power. Follow the instructions below to connect and install the product.

- It is recommended to use optional output cables that are shielded for connection to reduce disturbance and noise from outside. Connection using an alligator clip or non-shielded cable is not recommended.
- If there is a device including any transformer such as a DC power supply nearby, install this product as far as possible from it.
- Install the product in a location where there is as little vibration as possible.
- Place and use the product in a stable location.

3.4.1 Connecting with SA-600 Series

The output cable A (PA-001-2372) is available to connect this product to SA-600 series. Contact us or our agent.

The following figure shows connection using the output cable A. To use SA-600 series, set the output voltage of this product to ± 15 V (turn VOLTAGE ADJUST fully clock wise).

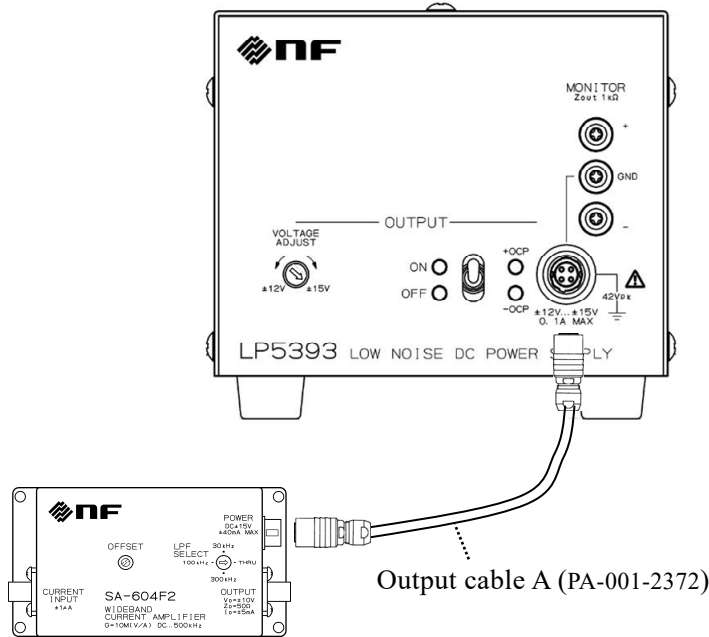

Figure 3-6 Connecting with SA-600 Series

⚠ WARNING

To prevent electric shock, do not apply a voltage greater than 42 Vpk (DC + ACpeak) between GND of the output terminal of this product and chassis GND.

If the voltage exceeds this value, the internal voltage limiting element works to suppress the voltage, but if the applied voltage (energy) is large, the voltage limiting element of this product may be damaged by heat.

⚠ CAUTION

Do not disconnect and connect the output cable A when this product output is on. SA-600 series may be damaged.

3.4.2 Connecting with SA-200 and SA-400 Series except for SA-230F5

The output cable B (PA-001-2373) is available to connect this product to SA-200 and SA-400 series except for SA-230F5. Contact us or our agent.

The following figure shows connection using the output cable B. To use SA-200 and SA-400 series except for SA-230F5, set the output voltage of this product to ± 15 V (turn VOLTAGE ADJUST fully clock wise).

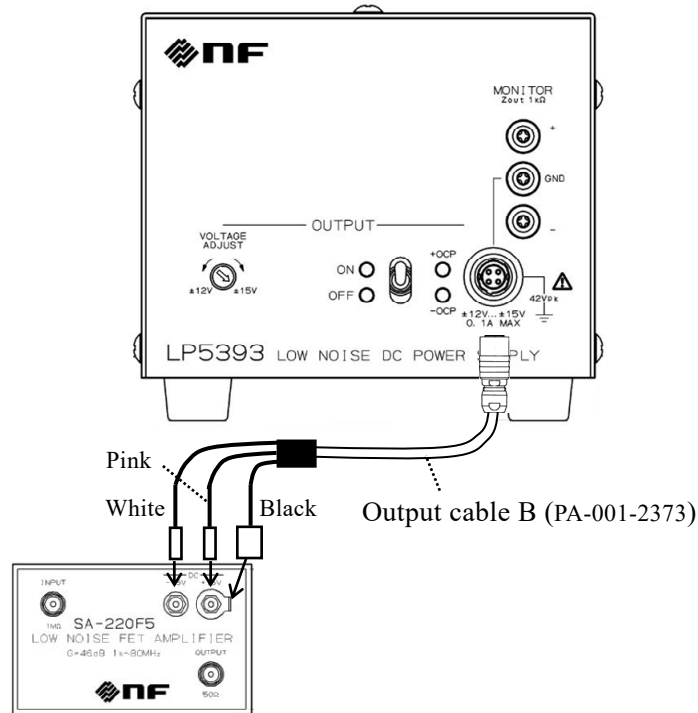

Figure 3-7 Connecting with SA-200 and SA-400 Series except for SA-230F5

⚠ WARNING

To prevent electric shock, do not apply a voltage greater than 42 Vpk (DC + ACpeak) between GND of the output terminal of this product and chassis GND.

If the voltage exceeds this value, the internal voltage limiting element works to suppress the voltage, but if the applied voltage (energy) is large, the voltage limiting element of this product may be damaged by heat.

⚠ CAUTION

Do not disconnect and connect the output cable B when this product output is on. SA-200 and SA-400 series may be damaged.

If the power supply for SA-200 and SA-400 series is connected in reverse, SA-200 and SA-400 series may be damaged. Before connection, check the power polarity again.

3.4.3 Connecting with SA-230F5

The output cable C (PA-001-2374) is available to connect this product to SA-230F5. Contact us or our agent.

The following figure shows connection using the output cable C. To use SA-230F5, set the output voltage of this product to ± 15 V (turn VOLTAGE ADJUST fully clock wise).

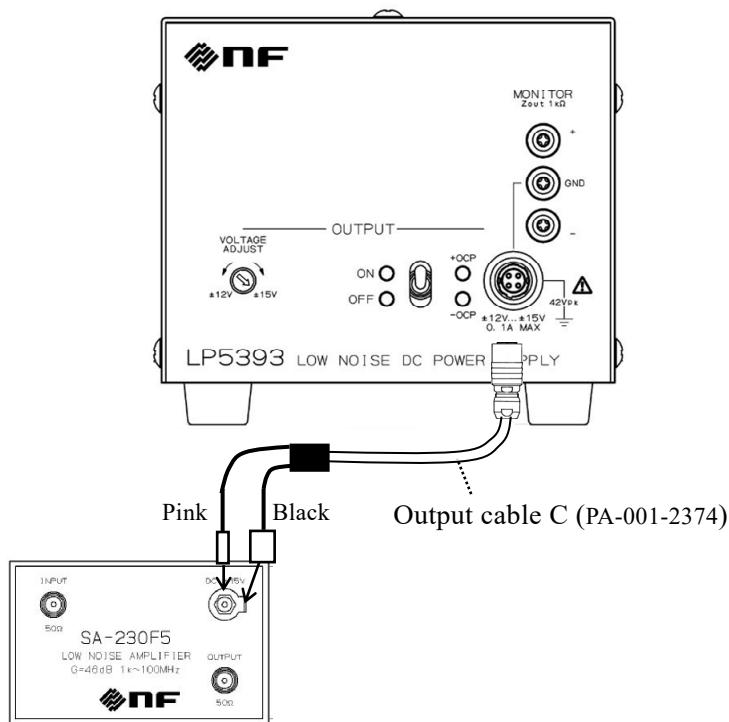

Figure 3-8 Connecting with SA-230F5

WARNING

To prevent electric shock, do not apply a voltage greater than 42 Vpk (DC + ACpeak) between GND of the output terminal of this product and chassis GND.

If the voltage exceeds this value, the internal voltage limiting element works to suppress the voltage, but if the applied voltage (energy) is large, the voltage limiting element of this product may be damaged by heat.

CAUTION

Do not disconnect and connect the output cable C when this product output is on. SA-230F5 may be damaged.

3.4.4 Connecting with Evaluation Kit PA-001-2179

Wide Band Current Amplifier SA-600 Series substrate mounting type CA-550 Series and CA-650 Series are available.

Evaluation Kit PA-001-2179 to evaluate CA-550/CA-650 Series is available. The output cable A (PA-001-2372) is available to connect this product to the Evaluation Kit PA-001-2179. Contact us or our agent.

The following figure shows connection using the output cable A. To operate the CA-550 Series or CA-650 Series by mounting it to the Evaluation Kit PA-001-2179, set the output voltage of this product to ± 15 V (turn VOLTAGE ADJUST fully clock wise).

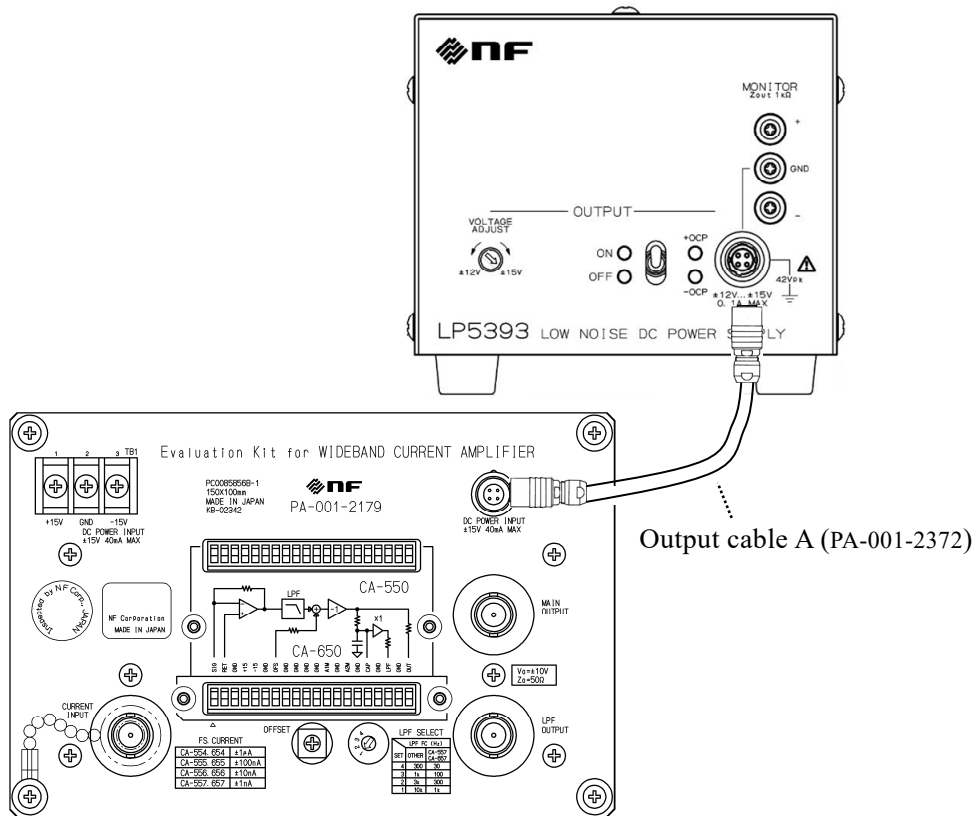

Figure 3-9 Connecting with Evaluation Kit PA-001-2179

WARNING

To prevent electric shock, do not apply a voltage greater than 42 Vpk (DC + ACpeak) between GND of the output terminal of this product and chassis GND.

If the voltage exceeds this value, the internal voltage limiting element works to suppress the voltage, but if the applied voltage (energy) is large, the voltage limiting element of this product may be damaged by heat.

CAUTION

Do not disconnect and connect the output cable A when this product output is on. The module connected to the valuation kit may be damaged.

3.4.5 Connecting with BNC Adapter

Optional BNC adapter (PA-001-2590) for converting HR10 series to BNC is available.

Output cable A (PA-001-2372) is available to connect this product to the BNC adapter. Contact us or our agent.

The following figure shows connection using the output cable A.

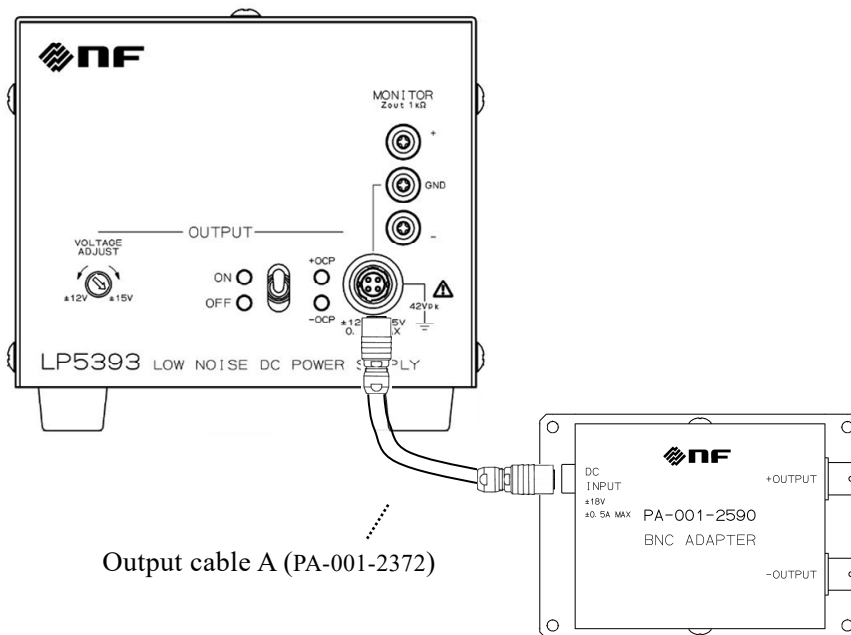

Figure 3-10 Connecting with BNC Adapter

⚠ WARNING

To prevent electric shock, do not apply a voltage greater than 42 Vpk (DC + ACpeak) between GND of the output terminal of this product and chassis GND.

If the voltage exceeds this value, the internal voltage limiting element works to suppress the voltage, but if the applied voltage (energy) is large, the voltage limiting element of this product may be damaged by heat.

⚠ CAUTION

The chassis of the BNC adapter and output GND have the same electric potential. When the BNC adapter is used by applying voltage to the output GND, do not connect the BNC adapter with the chassis GND of this product.

3.4.6 Connecting with Binding Post Adapter

Optional binding post adapter (PA-001-2591) for converting HR10 series to binding post is available.

Output cable A (PA-001-2372) is available to connect this product to the binding post adapter. Contact us or our agent.

The following figure shows connection using the output cable A.

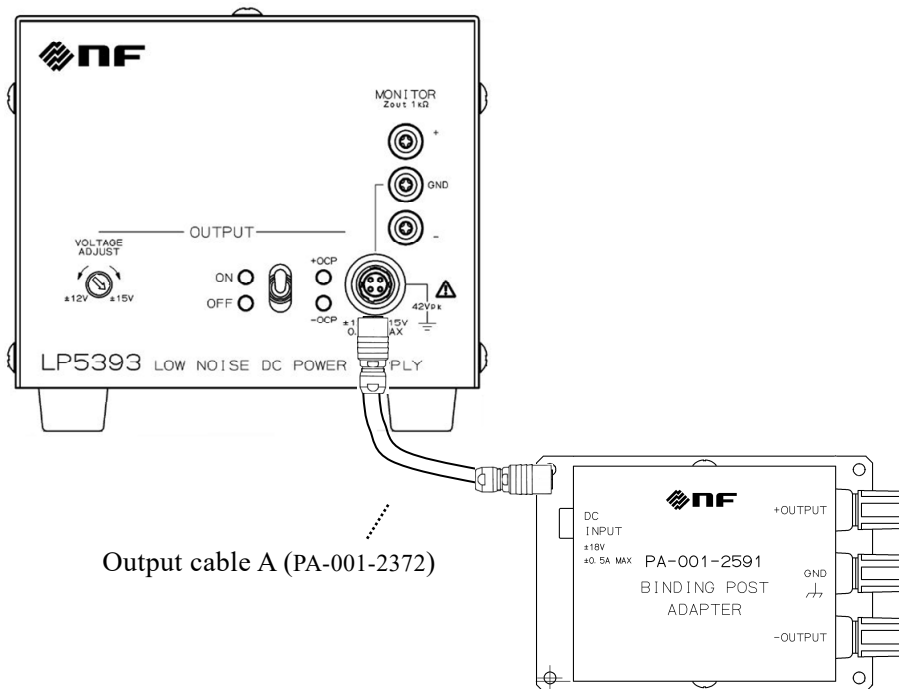

Figure 3-11 Connecting with Binding Post Adapter

⚠ WARNING

To prevent electric shock, do not apply a voltage greater than 42 Vpk (DC + ACpeak) between GND of the output terminal of this product and chassis GND.

If the voltage exceeds this value, the internal voltage limiting element works to suppress the voltage, but if the applied voltage (energy) is large, the voltage limiting element of this product may be damaged by heat.

⚠ CAUTION

The chassis of the binding post adapter and output GND have the same electric potential. When the binding post adapter is used by applying voltage to the output GND, do not connect the binding post adapter with the chassis GND of this product.

3.5 Turning On Power and Warm-up Time

This product exhibits the specified performance immediately after the power is turned on, but if you need a stable DC voltage within ± 50 ppm, allows the product to warm up for at least 30 minutes before use.

For details on the Long Time drift characteristic, refer to Figure 6-4 in Standard Data.

3.6 Protection Functions and Display

3.6.1 Overcurrent Protection

If the output current of this product is over ± 0.15 A, OCP LED turns on to indicate that the product has over the rated current.

The overcurrent protection is based on a drooping characteristic of approximately ± 0.15 A. If the overcurrent protection function works, the OCP LED turns on. If the output current falls below approximately ± 0.1 A, operation is automatically restored.

If the OCP LED turns on, turn off the output switch and check that the output load does not over the rating of this product and the connection is correct.

 **CAUTION**

Do not disconnect and connect connectors while output is on. This product or the connected load may be damaged.

3.6.2 Overheat Protection

If the internal temperature of this product is over 75 °C, the output turns off and the OUTPUT OFF LED flashes. If the internal temperature falls below 45 °C, normal operation is automatically restored.

A load short circuit over a long period of time or continuous operation at a room temperature of 50 °C or more works the overheat protection function. If the overheat protection function is works, check that the environmental conditions and output load are within the specifications.

 **CAUTION**

If this product is used under environmental conditions that over the specifications (0 to $+50$ °C, 5 to 85 %RH [absolute humidity 1 to 25 g/m³ or lower]), this product may malfunction.

4. Maintenance

4.1	Preface	4-1
4.2	Daily Maintenance	4-1
4.3	Storage, Repacking, and Transportation.....	4-1
4.4	Troubleshooting	4-2

4.1 Preface

- This chapter describes the following instructions.
 - Precautions and storage method when the product is not used for a long period of time.
 - Precautions for repacking and transportation.

For the simplified operation check, refer to 2.4.

If the specifications fail to be met in the operation check or performance test, contact NF Corporation for calibration or repair.

4.2 Daily Maintenance

- If the panels and cases are dirty

Wipe off the dirt with a soft cloth. To remove persistent contamination, wipe with a cloth that has been soaked in neutral detergent and then wrung out.

Never use any volatile solvents like thinner or benzene or a chemical cleaning cloth, as they may cause the surface finish to deteriorate or peel off.

4.3 Storage, Repacking, and Transportation

- Storage when not used for a long period of time
 - Disconnect the power cord from the outlet and this product.
 - Store the product in a location free from falling objects and dust, such as a shelf or rack.
If dust may be present, cover the product with a cloth or polyethylene cover.
 - The environmental conditions for storage are $-10\text{ }^{\circ}\text{C}$ to $+60\text{ }^{\circ}\text{C}$ and 5 %RH to 95 %RH. However, avoid a location where the temperature fluctuates significantly or where the product will be exposed to direct sunlight, and store it in an environment as close to room temperature as possible.
- Repacking and Transportation

When repacking the product to transport or send it for repairs, pay attention to the following instructions.

 - Wrap the product in a polyethylene bag or sheet.
 - Prepare a carton box that can well withstand the weight of the product and is of a large enough size to accommodate it.
 - Fill the carton box with a cushioning material so that the top, bottom, and six sides of the product can be protected.
 - When making a request for transportation, inform the transport operator that the product is a precision instrument.

4.4 Troubleshooting

If a problem such as the following occurs, take the necessary action. If the problem still cannot be resolved, contact us or our agent.

Table 4-1 Actions When Problems Occur

Symptom	Possible Cause	Necessary Action
+OCP LED or -OCP LED turns on	Output current is greater than 0.15 A.	Turn off the output and reduce the current of the connected load to 0.1 A or lower.
OUTPUT OFF LED flashes	Temperature is high.	Reduce the temperature of the operating environment to 50 °C or lower. If heat discharge is prevented, enable it. To reduce the internal temperature, this product may need to be left for at least 2 hours in the guaranteed operating environment to allow it to cool down before restarting.
All LED's don't turn on	The fuse is blown.	Check whether the fuse in the fuse holder is blown, and if necessary, replace it. Check that the voltage set in VOLTAGE SELECTOR matches the voltage of the outlet. If necessary, select the correct voltage with a Coin-driver.
Output voltage is not normal	Voltage in VOLTAGE SELECTOR is not correct.	Check that the voltage set in VOLTAGE SELECTOR matches the voltage of the outlet. If necessary, select the correct voltage with a Coin-driver.

WARNING

This product has high-voltage portions inside. Never remove the cover.

When inspection into the inside of the product is needed, never allow anybody to touch the innards except our certified service engineers.

5. Specifications

5.1	LP5393 Specifications	5-1
5.1.1	Type	5-1
5.1.2	Output Characteristics	5-1
5.1.3	Input Characteristics	5-2
5.1.4	Others	5-2
5.2	BNC Adapter Specifications	5-4
5.2.1	Rating	5-4
5.2.2	Environmental Conditions	5-4
5.2.3	Dimensions and Weight	5-4
5.2.4	Standard	5-4
5.2.5	Block Diagram	5-4
5.3	Binding Post Adapter Specifications	5-5
5.3.1	Rating	5-5
5.3.2	Environmental Conditions	5-5
5.3.3	Dimensions and Weight	5-5
5.3.4	Standard	5-5
5.3.5	Block Diagram	5-5
5.4	External Dimensions	5-6
5.4.1	LP5393 External Dimensions	5-6
5.4.2	BNC Adapter External Dimensions	5-7
5.4.3	Binding Post Adapter External Dimensions	5-8

5.1 LP5393 Specifications

Output current = ± 0.1 A, unless otherwise noted.

5.1.1 Type

Series regulator

5.1.2 Output Characteristics

5.1.2.1 Voltage/Current

Voltage	± 15 V ± 1 % when adjuster turned all the way to right. ± 12 V ± 1 % when adjuster turned all the way to left.
Voltage adjustment method	Set with the front panel adjuster.
Maximum current	± 0.1 A
Output ON/OFF	Set with the front panel switch.
Output monitor	MONITOR terminal on the front panel ($Z_{out} = 1$ k Ω).

5.1.2.2 Rated Voltage Characteristics

Input regulation (for power supply ± 10 %)	Within ± 3.5 mV
Load regulation (load 0 % reference for load 0 to 100 %)	Within ± 15 mV
Ripple noise (load 0 to 100 %, bandwidth 10 Hz to 20 MHz)	10 μ V _{rms} or lower (typical)
Output voltage temperature coefficient	± 20 ppm/ $^{\circ}$ C (typical)
Time drift (8 hours after warm-up)	± 50 ppm (typical)

5.1.2.3 Output Connector

HR10-7R-4S (73)

On the front panel

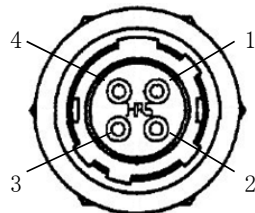

Pin numbers and connections

- 1: +OUT
- 2: GND
- 3: -OUT
- 4: GND

Figure 5-1 HR10-7R-4S (73) Pin Numbers and Connections

5.1.3 Input Characteristics

5.1.3.1 Power Supply

Input voltage	AC 100, 120, 220 and 240 V (select switch) $\pm 10\%$ However, AC 250 V or lower
Frequency	50/60 ± 2 Hz
Power consumption	25 VA or lower
Oversvoltage category	II

5.1.3.2 Fuse

Power supply voltage	Rated current	Rated voltage	Remark
100 V	0.315 A	250 V	Time-Lag type ϕ 5.2 \times 20 mm
120 V			
220 V	0.125 A		
240 V			

5.1.4 Others

5.1.4.1 Insulation Resistance

Between all power inputs and chassis	50 M Ω or more (with DC 500 V)
Between all power inputs and outputs	50 M Ω or more (with DC 500 V)
Between output GND and chassis	10 M Ω

5.1.4.2 Withstanding Voltage

Between all power inputs and chassis	AC 1500 V for 1 minute
Between all power inputs and outputs	AC 1500 V for 1 minute
Between output GND and chassis	± 42 Vpk (DC + ACpeak)

5.1.4.3 Protection Functions

Overcurrent protection	Drooping characteristic (approx. 0.15 A) self-recovery type.
Overcurrent status indication	By the front panel +OCP LED and -OCP LED.
Overheat protection	Output is turned off at an internal temperature of approx. 75 °C.
Overheat status indication	Front panel OUTPUT OFF LED flashes (self-recovery).

5.1.4.4 Environmental Conditions

Altitude	2000 m or lower
Operating temperature range	0 to +50 °C
Operating humidity range	5 to 85 %RH, absolute humidity 1 to 25 g/m ³ , non-condensation
Storage temperature range	-10 to +60 °C
Storage humidity range	5 to 95 %RH, absolute humidity 1 to 29 g/m ³ , non-condensation
Cooling method	Natural convection cooling
Pollution degree	2 (indoor use)
Warm-up time	30 minutes

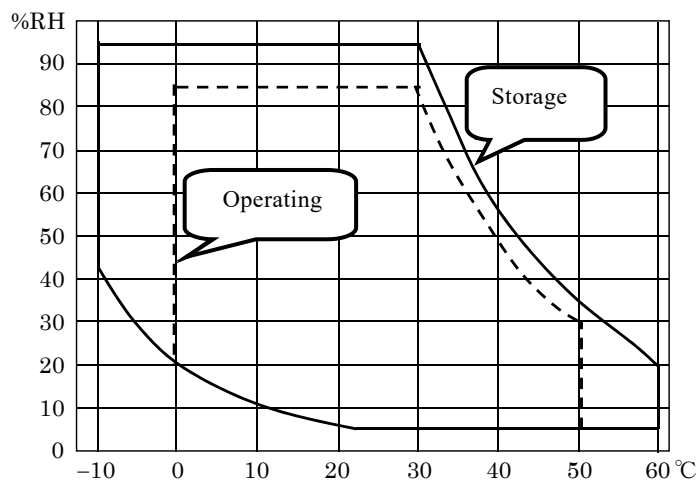

Figure 5-2 Temperature and Humidity Range Explanatory Graph

5.1.4.5 Dimensions and Weight

Dimensions (W×H×D)	107×86×330 mm (without protrusions)
Weight	Approx. 1.7 kg (without accessories)

5.1.4.6 Standards

RoHS	Directive 2011/65/EU
EMC (Models with CE marking on the rear panel only)	EN 61326-1 (Group1, Class A) EN 61000-3-2 EN 61000-3-3
Safety (Models with CE marking on the rear panel only)	EN 61010-1

5.2 BNC Adapter Specifications

5.2.1 Rating

Input/Output voltage	±18 V
Input/Output current	±0.5 A

5.2.2 Environmental Conditions

Operating temperature range	0 to +50 °C
Storage temperature range	-10 to +60 °C
Pollution degree	2 (indoor use)

5.2.3 Dimensions and Weight

Dimensions (W×H×D)	With bottom plate: 100×30×70 mm (without protrusions) Without bottom plate: 78×26×64 mm (without protrusions)
Weight	Approx. 230 g

5.2.4 Standard

RoHS	Directive 2011/65/EU
------	----------------------

5.2.5 Block Diagram

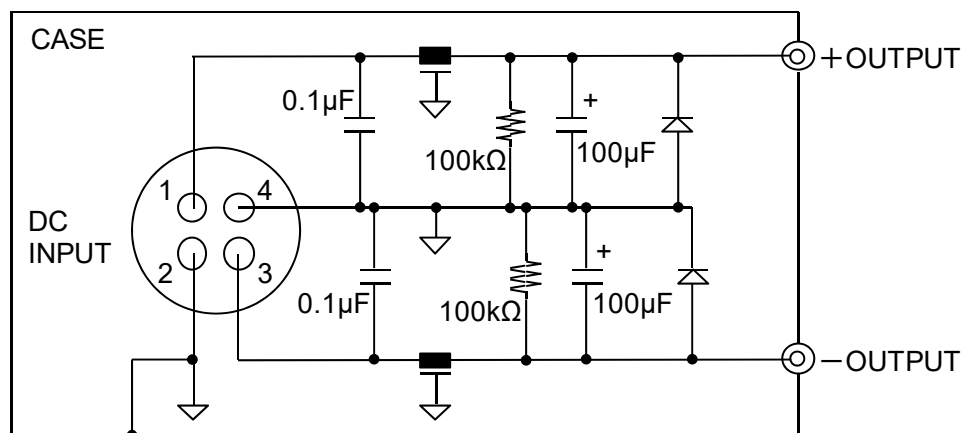

Figure 5-3 BNC Adapter Block Diagram

5.3 Binding Post Adapter Specifications

5.3.1 Rating

Input/Output voltage	$\pm 18\text{ V}$
Input/Output current	$\pm 0.5\text{ A}$

5.3.2 Environmental Conditions

Operating temperature range	0 to +50 °C
Storage temperature range	-10 to +60 °C
Pollution degree	2 (indoor use)

5.3.3 Dimensions and Weight

Dimensions (W×H×D)	With bottom plate: 100×30×70 mm (without protrusions) Without bottom plate: 78×26×64 mm (without protrusions)
Weight	Approx. 240 g

5.3.4 Standard

RoHS	Directive 2011/65/EU
------	----------------------

5.3.5 Block Diagram

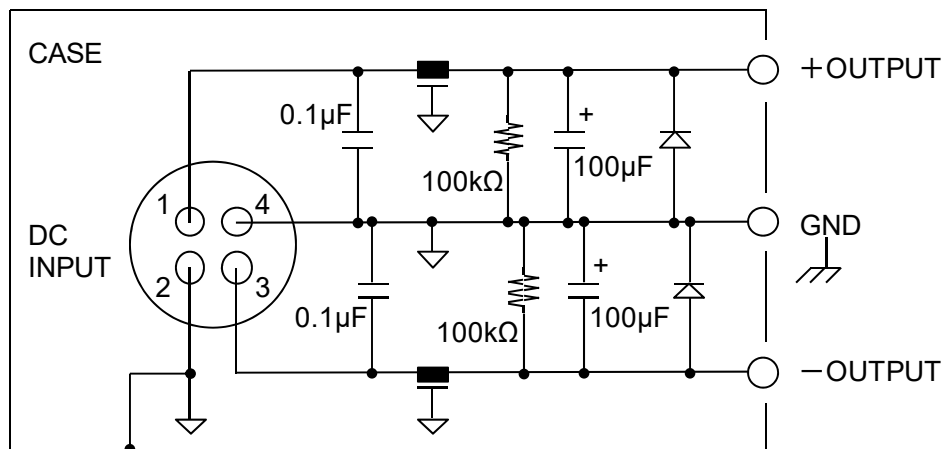

Figure 5-4 Binding Post Adapter Block Diagram

5.4.2 BNC Adapter External Dimensions

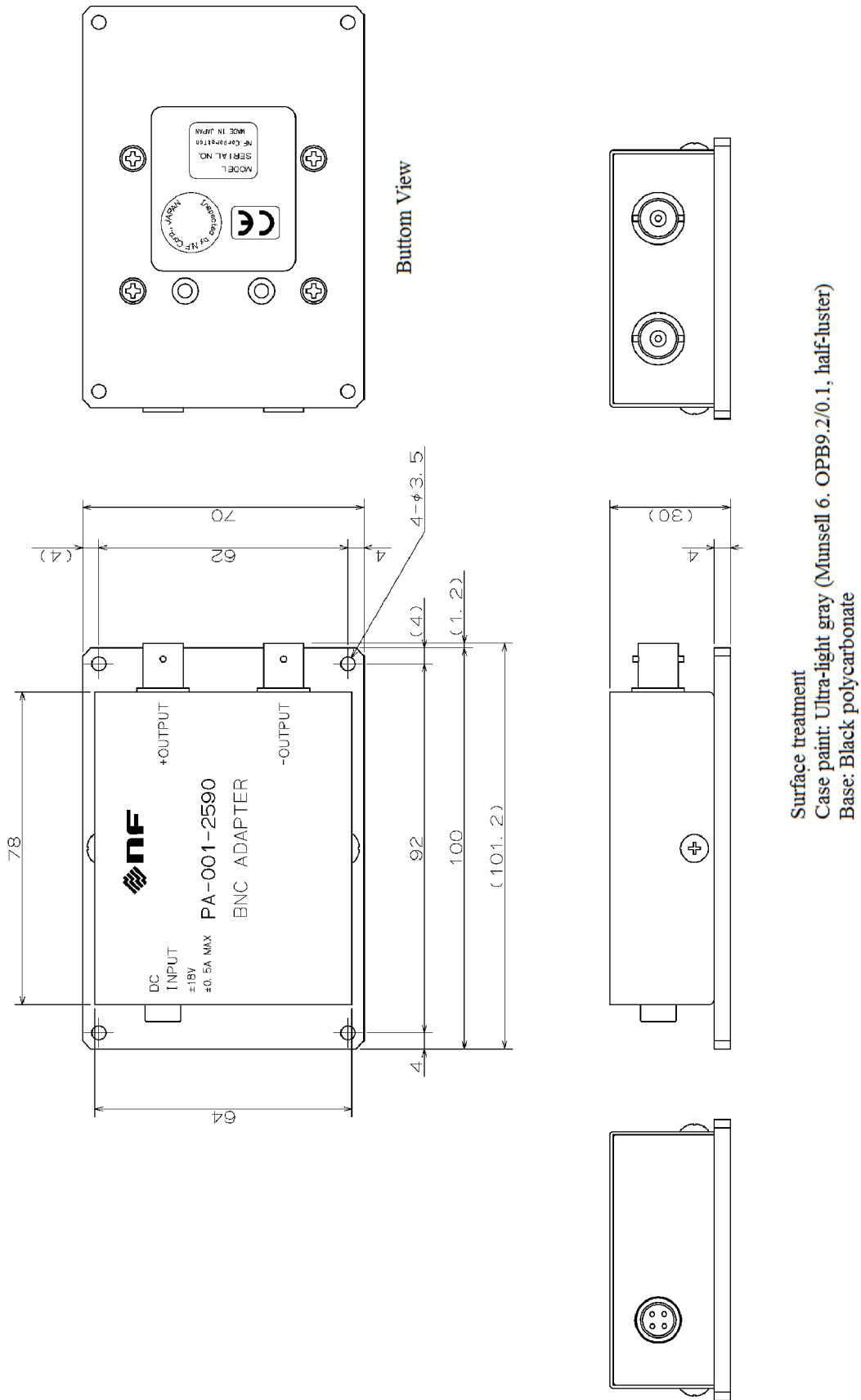

Figure 5-6 BNC Adapter External Dimensions

5.4.3 Binding Post Adapter External Dimensions

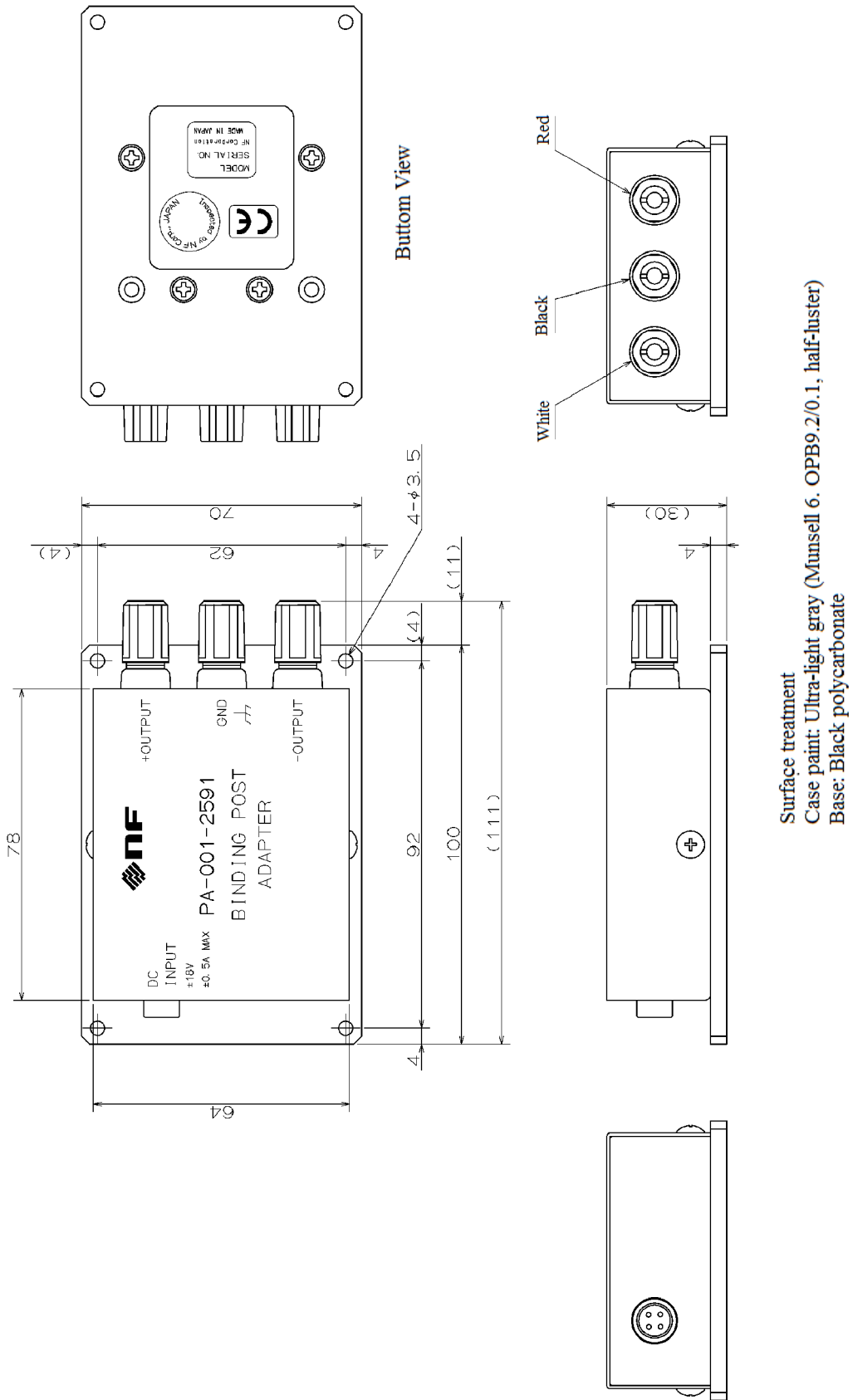

Figure 5-7 Binding Post Adapter External Dimensions

6. Standard Data

6.1	Standard Data.....	6-1
6.2	Output Noise Voltage Waveforms	6-1
6.3	Output Noise Voltage Density Frequency Characteristic.....	6-2
6.4	Long Time Drift Characteristic	6-2
6.5	Temperature Drift.....	6-3

6.1 Standard Data

This chapter describes the standard data as a reference. This data shows the average values obtained by measuring the performance of individual products. The performance of this product may not achieve the level of this data, but all products have been strictly tested before shipment to check that they meet the specifications.

6.2 Output Noise Voltage Waveforms

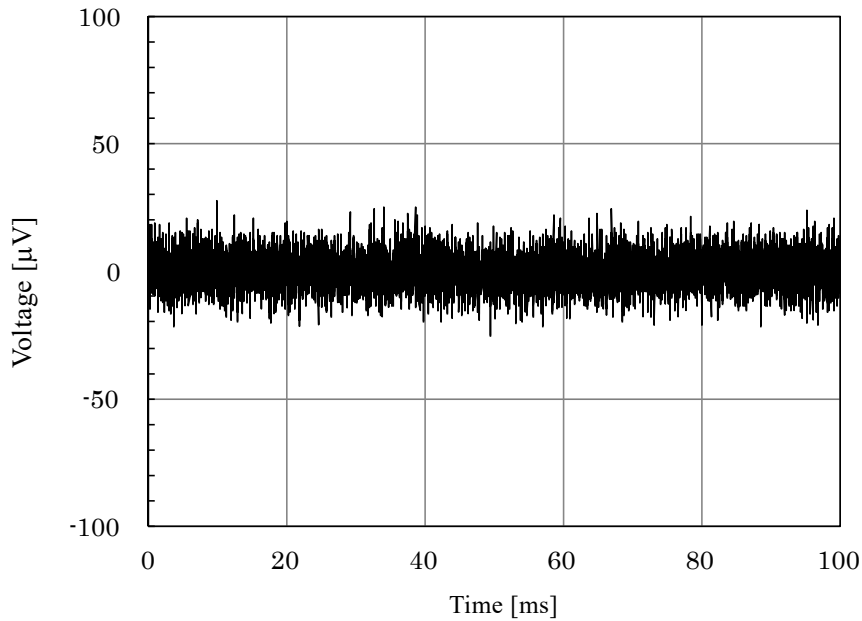

Figure 6-1 Output Noise Voltage Waveform (+15 V Output, Rated Load, Bandwidth 10 Hz to 20 MHz)

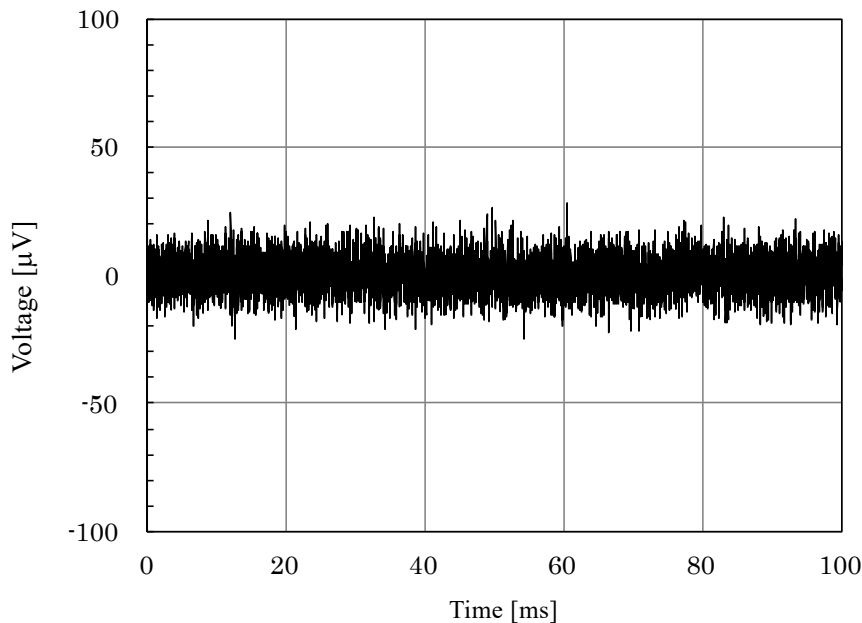

Figure 6-2 Output Noise Voltage Waveform (-15V Output, Rated Load, Bandwidth 10 Hz to 20 MHz)

6.3 Output Noise Voltage Density Frequency Characteristic

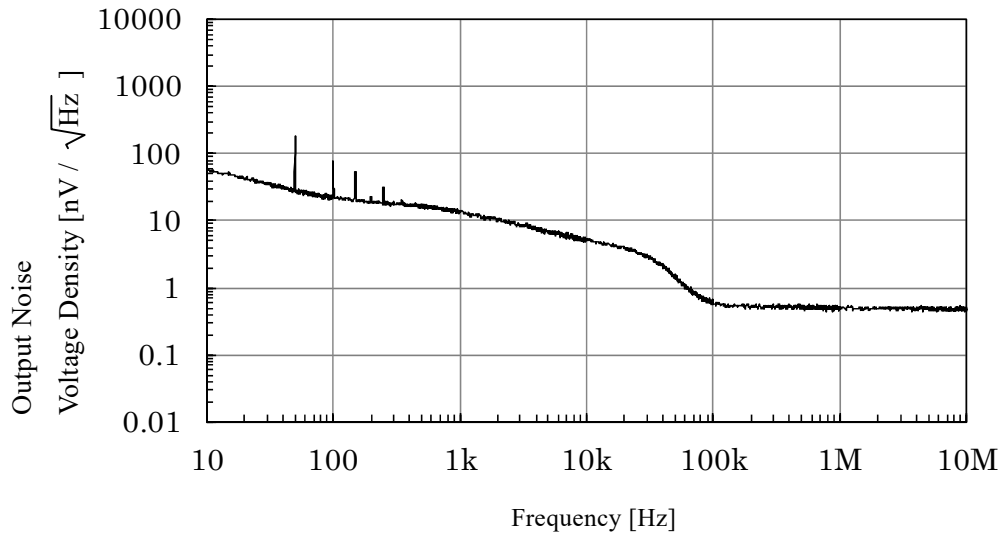

Figure 6-3 Output Noise Voltage Density Frequency Characteristic (+15 V Output, Rated Voltage)

6.4 Long Time Drift Characteristic

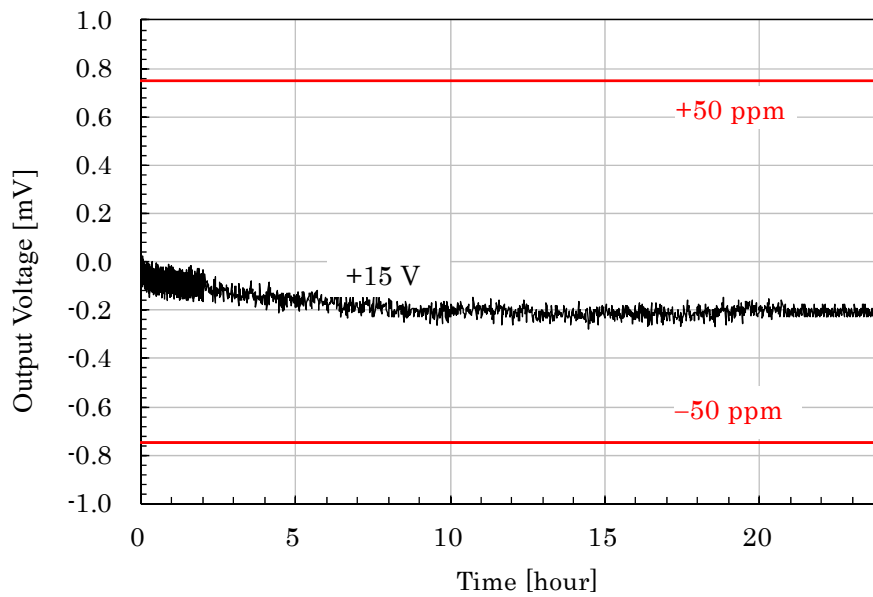

Figure 6-4 Long Time Drift Characteristic
(Rated Load, Output Voltage Reference at Time of Start)

6.5 Temperature Drift

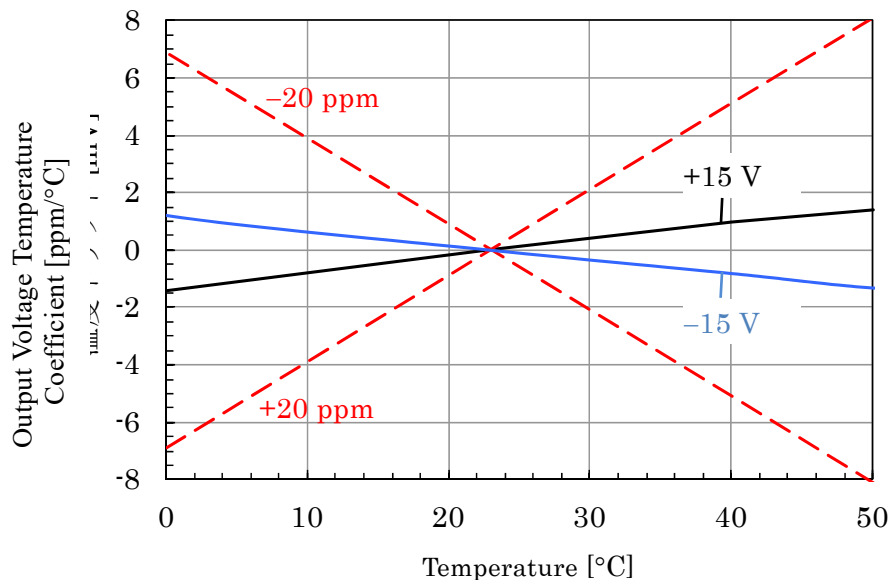

Figure 6-5 Temperature Drift (Rated Load)

— WARRANTY —

NF Corporation certifies that this product was thoroughly tested and inspected and found to meet its published specifications when it was shipped from our factory.

All **NF** products are warranted against defects in materials and workmanship for a period of one year from the date of shipment. During the warranty period, **NF** will repair the defective product without any charge for the parts and labor. For repair service under warranty, the product must be returned to either **NF** or an agent designated by **NF**. Purchaser shall prepay all shipping charge, duties and taxes for the product to either **NF** or the agent from another country, and shipping charge for the return of the product to purchaser shall be paid by **NF** side.

This warranty shall not apply to any defect, failure or damage caused by a) improper use; b) improper or inadequate maintenance and care; or c) modification by purchaser or personnel other than **NF** representatives.

NF Corporation

If there are any misplaced or missing pages, we will replace the manual. Contact the sales representative.

NOTES

- Reproduction of the contents of this manual is forbidden by applicable laws.
- The contents of this manual may be revised without notice.
- Information provided in this manual is intended to be accurate and reliable. However, we assume no responsibility for any damage regarding the contents of this manual.
- We assume no responsibility for influences resulting from the operations in this manual.

Copyright 2015-2022, **NF Corporation**

LP5393 INSTRUCTION MANUAL

NF Corporation

6-3-20, Tsunashima Higashi, Kohoku-ku, Yokohama
223-8508 JAPAN

Phone: +81-45-545-8128 Fax: +81-45-545-8187

