



LDGSS

USER'S MANUAL

GAS STREAM SELECTION SYSTEM



LDGSS

Gas Stream Selection System

USER'S MANUAL
V4.5

Printed in Canada
Copyright 2019

Table of Content

1	Forewarning	4
2	Warranty, maintenance and service policies	5
3	Cautions & Warnings	8
3.1	Electrical shock hazard	8
3.2	Possible explosion hazard	8
4	Declaration of conformity	9
5	Specifications	10
6	Installation	11
7	Hardware description.....	12
7.1	Rotary Switch.....	12
7.2	Sample bypass flowmeter/valve mounted on the front panel	12
7.3	Diaphragm Valve version (6 streams & 4 streams versions).....	13
7.4	Electric 3 ways solenoid valve version	14
7.5	Control board	14
8	Leak certification.....	15
9	Drawings & Schematics	17
9.1	Back Panel Identification	17
9.2	Front Panel Identification.....	19
9.3	Internal parts identification (version 3 ways solenoid valve, 8 streams)	20
9.4	Internal part identification (version diaphragm's valve, pneumatic actuation, 8 streams).....	21
9.5	Cabinet dimensions	22
9.6	Internal schematic with 3 ways electric valve (8 streams).....	23
9.7	Internal schematic with pneumatic diaphragm valve (10 streams).....	24
9.8	Internal schematic with pneumatic diaphragm valve double block and bleed (6 streams).....	25
10.	Ordering information	26
10.1	Options	27

1 Forewarning

Any user that wants to use the LDGSS Gas Stream Selection System must read this manual. It contains important information to successfully operate the instrument. LDetek makes assumptions that all operators have taken the time to read this information before installing, operating and troubleshooting the system.

If any error is suspected by the reader, please contact LDetek. LDetek reserves the right to make changes to subsequent editions of this document without prior notice to holders of this edition.

We want to thank you to choose LDetek.

2 Warranty, maintenance and service policies

Goods and part(s) (excluding consumable) manufactured by the seller are warranted to be free from defects in workmanship and material under normal use and service for a period of **twelve (12)** months after installation and start-up and not exceeding **18 months** from shipment date. Consumable, chemical trap, O-rings, etc., are warranted to be free from defects in workmanship and material under normal use and service for a period of ninety (90) days from the date of shipment by the seller. Goods, part(s) proven by the seller to be defective in workmanship and/or material shall be replaced or repaired, free of charge, F.O.B. Seller's factory provided that the goods, part(s) are returned to Seller's designated factory, transportation charges prepaid, within the twelve (12) months after installation and start-up and not exceeding 18 months from shipment date. In the case of consumable; within the ninety (90) days period of warranty, a defect in goods, part(s) and consumable of the commercial unit shall not operate to condemn such commercial unit when such goods, part(s) and consumable are capable of being renewed, repaired or replaced.

The Seller shall not be liable to the Buyer, or to any other person, for the loss or damage directly or indirectly, arising from the use of the equipment of goods, from breach of any warranty, or from any other cause.

ALL OTHER WARRANTIES, EXPRESSED OR IMPLIED ARE HEREBY EXCLUDED.

IN CONSIDERATION OF THE HEREIN STATED PURCHASE PRICE OF THE GOODS, SELLER GRANTS ONLY THE ABOVE STATED EXPRESS WARRANTY. NO OTHER WARRANTIES ARE GRANTED INCLUDING, BUT NOT LIMITED TO, EXPRESS AND IMPLIED WARRANTIES OF MERCHANTABILITY AND FITNESS FOR A PARTICULAR PURPOSE.

THIS WARRANTY IS THE ONLY WARRANTY MADE BY LDETEK INC. WITH RESPECT TO THE GOODS DELIVERED HEREUNDER, AND NO EMPLOYEE, REPRESENTATIVE OR OTHER PERSON OR ENTITY IS AUTHORIZED TO ASSUME FOR LDETEK INC ANY OBLIGATION OR LIABILITY BEYOND OR AT VARIANCE WITH THIS WARRANTY IN CONNECTION WITH THE SALE OF LDETEK PRODUCTS.

Limitations of Remedy. SELLER SHALL NOT BE LIABLE FOR DAMAGES CAUSED BY DELAY IN PERFORMANCE. THE SOLE AND EXCLUSIVE REMEDY FOR BREACH OF WARRANTY SHALL BE LIMITED TO REPAIR OR REPLACEMENT UNDER THE STANDARD WARRANTY CLAUSE. IN NO CASE, REGARDLESS OF THE FORM OF THE CAUSE OF ACTION, SHALL SELLER'S LIABILITY EXCEEDS THE PRICE TO BUYER OF THE SPECIFIC GOODS MANUFACTURED BY SELLER GIVING RISE TO THE CAUSE OF ACTION. BUYER AGREES THAT IN NO EVENT SHALL SELLER'S LIABILITY EXTEND TO INCLUDE INCIDENTAL OR CONSEQUENTIAL DAMAGES. CONSEQUENTIAL DAMAGES SHALL INCLUDE BUT ARE NOT LIMITED TO, LOSS OF

ANTICIPATED PROFITS, LOSS OF USE, LOSS OF REVENUE, COST OF CAPITAL AND DAMAGE OR LOSS OF OTHER PROPERTY OR EQUIPMENT. IN NO EVENT SHALL SELLER BE LIABLE FOR PROPERTY DAMAGE AND/OR THIRD PARTY CLAIMS COVERED BY UMBRELLA INSURANCE AND/OR INDEMNITY COVERAGE PROVIDED TO BUYER, ITS ASSIGNS, AND EACH SUCCESSOR INTEREST TO THE GOODS PROVIDED HERE UNDER.

Major force. Seller is not liable for failure to perform due to labor strikes or acts beyond Seller's direct control.

SERVICE POLICY

1. If a product should fail during the warranty period, it will be repaired free of charge. For out of warranty repairs, the customer will be invoiced for repair charges at current standard labor and materials rates.
2. Customers who return products for repairs, within the warranty period, and the product is found to be free of defect, may be liable for the minimum current repair charge.
3. For parts replacement, the original part must be returned with serial and model numbers of the system. **NO PART WILL BE SHIPPED IF THE ORIGINAL IS NOT SENT BACK TO LDETEK INC.**

RETURNING A PRODUCT FOR REPAIR

Upon determining that repair services are required, the customer must :

10. Obtain an RMA (Return Material Authorization) number.
10. Supply a purchase order number or other acceptable information.
10. Include a list of problems encountered along with name, address and telephone, and RMA number.
10. **Ship the system in its original crating or equivalent. Failure to properly package the system will automatically void the warranty.**
10. **Every gas connection must be capped with appropriate metal caps. Failure to do so will automatically void the warranty.**
10. Write RMA number on the outside of the box.
10. Use a LDetek approved carrier. Also, the delivery must be sent to LDetek facilities. LDetek will not accept airport to airport delivery.
10. LDetek will not cover transport fees.

Other conditions and limitations may apply to international shipments.

PROPRIETARY RIGHTS

Buyer agrees that any LDetek's software, firmware and hardware products ordered or included in the goods ordered are proprietary of LDetek. No change, modification, defacement, alteration, reverse engineering, software decompilations nor reproduction of such software or hardware products, or disclosures of programming content to other parties is authorized without the express written consent of LDetek.

To maintain LDetek trade secret and other proprietary protection of such software and firmware, such items are not sold hereunder but are licensed to buyer.

LDetek Inc. reserves the right to interrupt all business relationship and warranty or service if there is any tentative from any customers to reverse engineering any of LDetek products or to tamper with any sealed module.

Trademarks and product identification as LDGSS are the property of LDetek Inc. and shall be used only in connection with LDetek's products. No third party could remove or deface any model number or marks.

3 Cautions & Warnings

Improper installation, operation or service of this analyzer may cause damage to the analyzer and void the manufacturer's warranty.

3.1 *Electrical shock hazard*

Do not operate unless the cabinet is securely closed. Servicing this instrument implies possible exposure to shock hazard level voltages which can cause death or serious injury.

For both safety and proper performance, this instrument **must** be connected to a properly grounded three-wire source of electrical power.

Both alarm switching relay contacts and digital output contacts wired to a separate power source must be disconnected before servicing.

Tampering or unauthorized substitution of components may adversely affect the safety of this product. Use only factory-approved components for repair.

3.2 *Possible explosion hazard*



Never introduce hydrogen and oxygen in the same system. LDetek isn't responsible if hydrogen and oxygen source is mixed in the same system. LDetek policy is to separate oxygen and hydrogen using two distinct system used in two separate areas.

With the use of any type of hazardous gases in the LDGSS, it is necessary to have the LDGSS system installed in a ventilated area. If the LDGSS can't be installed in a well-ventilated area, it is then necessary to have the purge option installed in the LDGSS.

It is the responsibility of the client to advise LDetek about the use and installation environment where will work the LDGSS.

This analyzer must be installed in laboratory environments: moisture- and vibration-free, with stable temperatures.

4 Declaration of conformity

EU Declaration of Conformity



1. **Product model:** LDGSS – Gas Stream Selector

2. **Name and address of the manufacturer:**

LDetek Inc.
990 Monfette E.
Thetford Mines, QC G6G 7K6
+1 (418) 755-1319
Email: info@ldetek.com



This product is in conformity with the following EU Directives ,Standard(s) or Normative Document(s):

3. **Directives.**

Low Voltage Directive (LVD) 2014/35/EU,

Electromagnetic Compatibility Directive (EMC) 2014/30/EU,

Restriction of Hazardous Substances (RoHS) Directive 2011/65/EU/2014/68/EU

Pressure Equipment Directive

This product does not bear CE marking for the Pressure Equipment Directive, but are supplied in accordance with Article 4, paragraph 3 of 2014/68/EU by using SEP (sound engineering practice) in the design and manufacturer and are provided with adequate instructions for use.

4. **Standards:**

CISPR 32: 2015 A1: 2019, Class A : Electromagnetic compatibility of multimedia equipment - Emission requirements

EN61010-1:2010 Safety Requirements for Electrical Equipment for Measurement, Control, and Laboratory Use - Part 1: General Requirements

5. **On behalf of the above-named company, I declare that under our sole responsibility, on the date that the equipment accompanied by this declaration is placed on the market, it conforms with all technical and regulatory requirements of the above listed EU Directives.**

A handwritten signature in blue ink, appearing to read "Dany Gagné".

Dany Gagné / CTO
Thetford Mines, QC
Date: 03/2022

5 Specifications

Number of Inlets:

- 2 to 10 streams configurable

Standard Features:

- Front mounted stream fast loop bypass valves & flowmeters
- Dry contacts that remotely give status of selected stream
- Local or Remote control via 12VDC or 24VDC supply
- Front mounted rotary switch selector for local control
- Electrical or pneumatic valves available
- Particle filter frit type 10 microns is mounted on each stream inlet
- Choice between purged pneumatic valve or 3 ways electric sample bypass valve

Options:

- BRP: Sample outlet back pressure regulator to maintain a constant ultra high purity sample outlet pressure control
- VPB: Valve purged box for toxic and/or hazardous gases
- PG: Purging gas inlet flowmeter/valve mounted on front panel to adjust the diaphragm valve purge flowrate
- PR: Stream inlet inline pressure regulator for reducing and adjusting the stream pressure below the maximum operating pressure
- C: Coating for aggressive or absorbent gases
- MBP: Metal bellow pump when sample pressure is below 2-3 psig
- O2: Oxygen clean certified
- DBB: Double block and bleed configuration

Sample Bypass adjustable valve flow range:

- 0 to 500 ml/min in reference to air installed by default (larger ranges possible for faster purge)

Gas Inlet & Outlet Connections:

- 1/16''- 1/8'' or 1/4'' Stainless Steel Compression Type Swagelok compatible.
- 1/8'' or 1/4'' Stainless Steel Ultra High Purity VCR type.

Purged Gas Vent Connections:

- 1/8'' - 1/4'' Stainless Steel Compression Type Swagelok compatible
- 1/8'' - 1/4'' Stainless Steel High Purity face seal (VCR) type

Supply:

- 85VAC to 240VAC 50/60Hz

Power Consumption:

- Max 15 watts

Maximum Operating Pressure:

- 30 PSIG (206Kpa) with 3 ways valve version
- 300 PSIG (2068Kpa) with stainless steel diaphragm valve version¹

Minimum Operating Pressure:

- 3 PSIG (20Kpa) (lowest pressure and vacuum mode applications can be achieved by adding the optional metal bellow pump)

Nominal Working Pressure:

- 20 PSIG (138Kpa)

Remote control voltage input:

- 12 VDC or 24VDC at 200mA maximum

Weight:

- Max 25 lbs (11Kg)

¹ Front mounted stream bypass valves are not available above 100PSIG

6 Installation

Some simple steps are required to make a successful installation.

1. Unpack the instrument from the box carefully and make a visual inspection.
2. Remove the plugs from the gas connections on the back panel.
3. Purge every gas line before to connect to the LDGSS gas inlet connections to avoid any liquids, dust, contaminants going in the LDGSS piping. A 10 microns frit particle filter is installed in every stream inlet to avoid any particles going in the device.
4. Connect each "Stream Inlet" to the appropriate stream channel. (Stream 1 to Stream 10 are available depending on the model version) For VCR face seal version, be sure to use a new gasket every time. Using an old gasket may result in leak and damaging the edging sealing joint.
5. Be sure the "Purge Vent" and the "Sample Bypass Vent" connections of the LDGSS are left to the atmospheric pressure. Any backpressure may result in gas mixing and contamination of the internal flow path of the device.
6. For the pneumatic version, the actuation gas line with a pressure range set between 65-100psig must be connected to actuation/purge inlet port on the back panel of the unit. When connected with a MultiDetek2 GC, the actuation gas is the same as the carrier gas of the GC which is generally set at 100psig.
7. Put the power on the unit. Refer to the electrical identification plate on the back panel next to the power inlet module for proper power source.
8. For proper purge and startup, the sample bypass flowrate must be adjusted at a minimum of 0.2LPM with the front valve/flowmeter. Each stream must be adjusted and purge.
9. For a complete purging of the internal plumbing and valves, each stream must be selected one by one and leave on purge for a minimum of 1 hour. Each stream must be selected for a one-hour period each. Once each stream has been selected, then the unit is ready to be used with the analytical equipment.
10. Connect the "Sample Outlet" of the LDGSS to the analyzer. For VCR face seal version, be sure to use a new gasket every time. Using a old gasket may result in leak and damaging the edging sealing joint.
11. For electrical wiring of the connector located at the rear panel that allow remote control and stream ID, refer to section 8.1 that describes the connections.

7 Hardware description

The LDGSS has different components included in the enclosure. This section will describe the main parts.

7.1 Rotary Switch



The rotary switch installed on the front panel is used to switch manually from stream 1 up to stream 9.

The R position must be selected if the LDGSS is controlled remotely via external 12VDC or 24VDC source.

The 12VDC or 24VDC source must be supplied from an external source to allow the remote control of the unit from a PLC.

A red led turns ON when the unit is on power.

7.2 Sample bypass flowmeter/valve mounted on the front panel

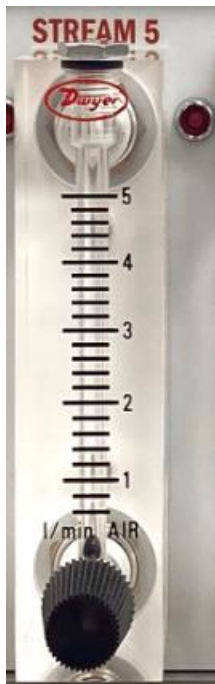

Each stream offers a sample bypass fast loop to purge each stream prior to get into the selection valve. The default range of the flow meter is 0-0.5LPM in reference to air media. Other ranges are possible.

A stainless-steel adjustment valve is mounted at the bottom of the flow meter to adjust to the desired flowrate.

The default model used can accept up to 100psig as maximum pressure. If higher pressure is required, it is suggested to install an inline pressure regulator to reduce the maximum pressure to 100psig prior to enter in the LDGSS.

7.3 Diaphragm Valve version (6 streams & 4 streams versions)

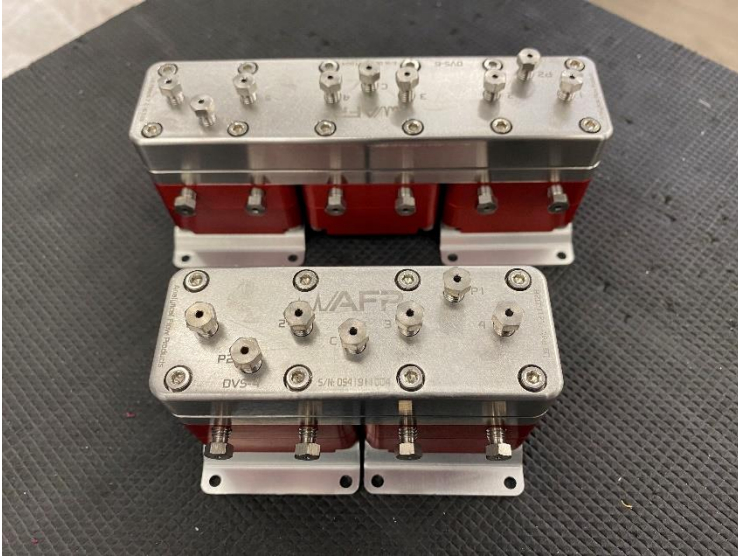

The tight shut-off diaphragm valves used are designed for ultra-high purity application. Up to 10 streams in one LDGSS unit can be mounted. No dead volume effects, continuous flow path and purge systems make it deal for UHP stream selector system. The purge feature prevents inboard and outboard contamination. The valve has independent normally closed ports ensuring complete sample blocking on power shut down. The actuation

pressure required is 65psig. The solenoid valves used for the stream actuation are mounted inside the LDGSS. A 12VDC or a 24VDC version is available depending on the requirements. The actuation pressure is regulated at 65psig by the internal pressure regulator, requiring a pressure inlet between 65-100psig on the actuation port.

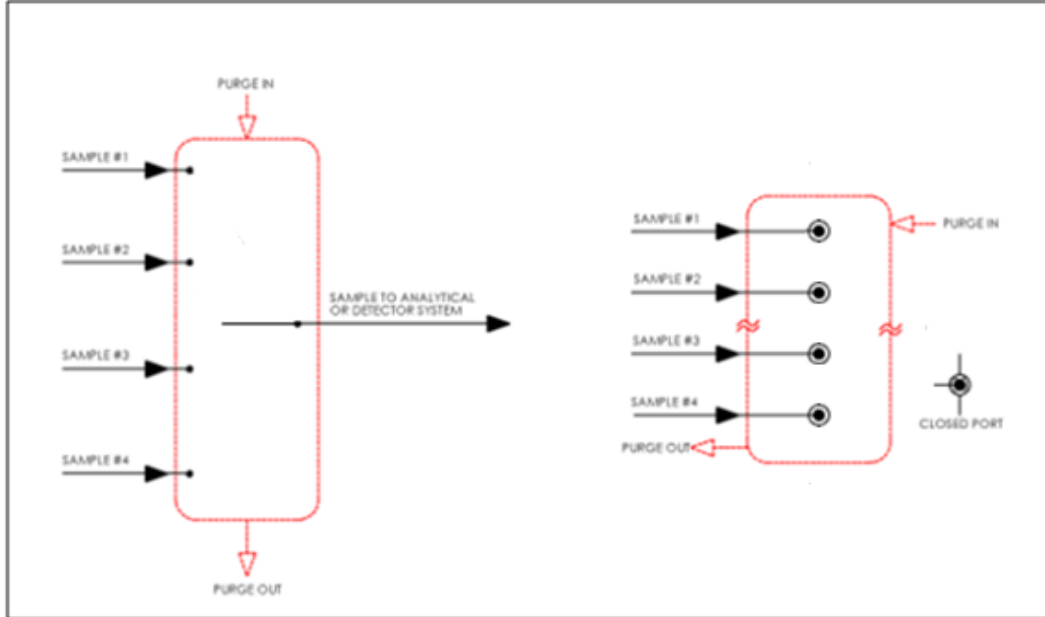

Flow diagram of a 4 streams diaphragm valve version.

Different materials and surface coatings are available for the diaphragm valve. Stainless Steel 316L is the default material. Hastelloy and Monel can be used for more aggressive gases. Different surface coating can also be done as sulfinert, silcosteel and silcolloy.

7.4 Electric 3 ways solenoid valve version

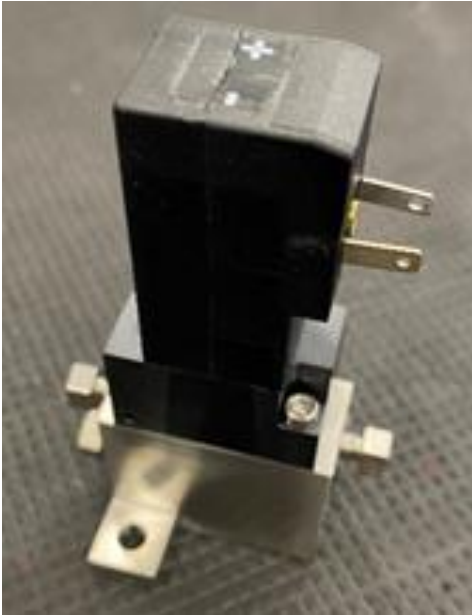

An electric actuated solenoid valve can be used for high purity ppb/ppm/% applications. Up to 10 streams in one LDGSS unit can be mounted. The 3 ways valve having its normally close port in sample bypass mode offers a quick response time by keeping a constant flowrate purging the valve body. All the unselected streams are mixed inside the same welded manifold to be flow regulated from the front mounted purge valve/flowmeter. This flow rate is evacuated by the purge vent gas vent. By this 3-way configuration, each stream is always purged with its own gas line. When, the stream is selected the flow rate is instantly directed from the bypass loop to the selected stream that is going to the analytical equipment for analysis. Having this type of configuration, no dead volume is present, and each stream is permanently purged. The valve

is mounted on a stainless-steel manifold having 1/16" single ferrule type fittings to eliminate any dead volume normally present in standard double ferrules compression fittings. Again, this precaution is in place to ensure purity and quick response time of the sampling system. Different surface coating can also be done as sulfinert, silcosteel and silcolloy.

7.5 Control board

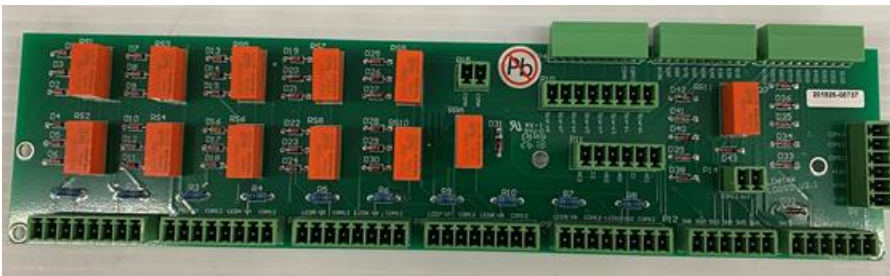

The control PSB is used to make all electrical connections between the different streams inside the LDGSS and the

external devices that control the LDGSS. The pcb can be configured for 12VDC or 24VDC, but this info must be supplied to LDetek prior to order a unit to be sure the proper hardware is installed for it. The DC voltage source is used to remotely controlled and select the streams from an external PLC system. The DC source must be supplied externally to the LDGSS. When the LDGSS is used in combination with a Multidetek2 GC, then the default DC voltage is supplied from the MD2 and is 12VDC. The control pcb also gives a dry contact signal from each selected stream.

8 Leak certification

Each LDGSS system is tested and certified using LDetek standard procedure. The procedure ensures the stream selector system is leak free. A certification sheet is included with every LDGSS.

In a first step, the LDGSS is pressurized under Helium and check for outboard leakage using a Helium sniffer.

In a second step, the LDGSS is installed on-line with a Nitrogen ppb analyzer to monitor the nitrogen level introduced by the LDGSS. See below the explanation of the certification chart included:

The calibrated trace nitrogen analyzer is then installed without the LDGSS and the flow rate is changed from 50sccm to 100sccm to evaluate the leak rate in the unit and the installation.

Leak Certification :

Trace ppb Nitrogen analyzer

Zero calibration(ppb)	Span calibration(ppb)	Reading on zero gas at 50sccm(ppb)	Reading on zero gas at 100sccm (ppb)
10	4110	13	10

Stream #	ppb reading at 50sccm	ppb reading at 100sccm
1	14	12
2	13	12
3	17	13

Then, the LDGSS is installed online with the trace nitrogen analyzer and each stream is tested with a flow rate of 50sccm and 100sccm. The trace nitrogen analyzer gives the leak rate introduced by each LDGSS stream.

Drawings
&
Schematics

9 Drawings & Schematics

9.1 Back Panel Identification

Stream Inlet 1/8" compression connections

Note: A 10 microns 1/8" frit type particle filter is mounted individually in each inlet)

Sample outlet 1/8" compression connection. Must be connected to the analyzer sample inlet.



Stream ID 1 to 10

These dry contacts are used to give the status of the selected stream. It's a normally open contact and the contact is closed when the stream is selected.

Common contact is Common ID

STR Remote 1 to 10

When the front rotary switch is at R position, the stream selection can be done remotely. A 12VDC or 24VDC (depending of the LDGSS configuration) must be supplied between the contacts "str remote x" and the "common rmt".

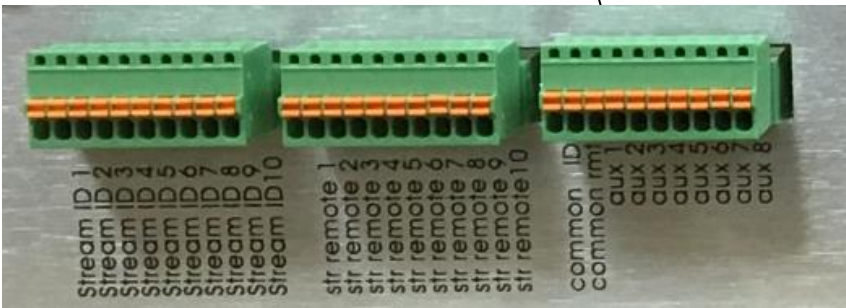

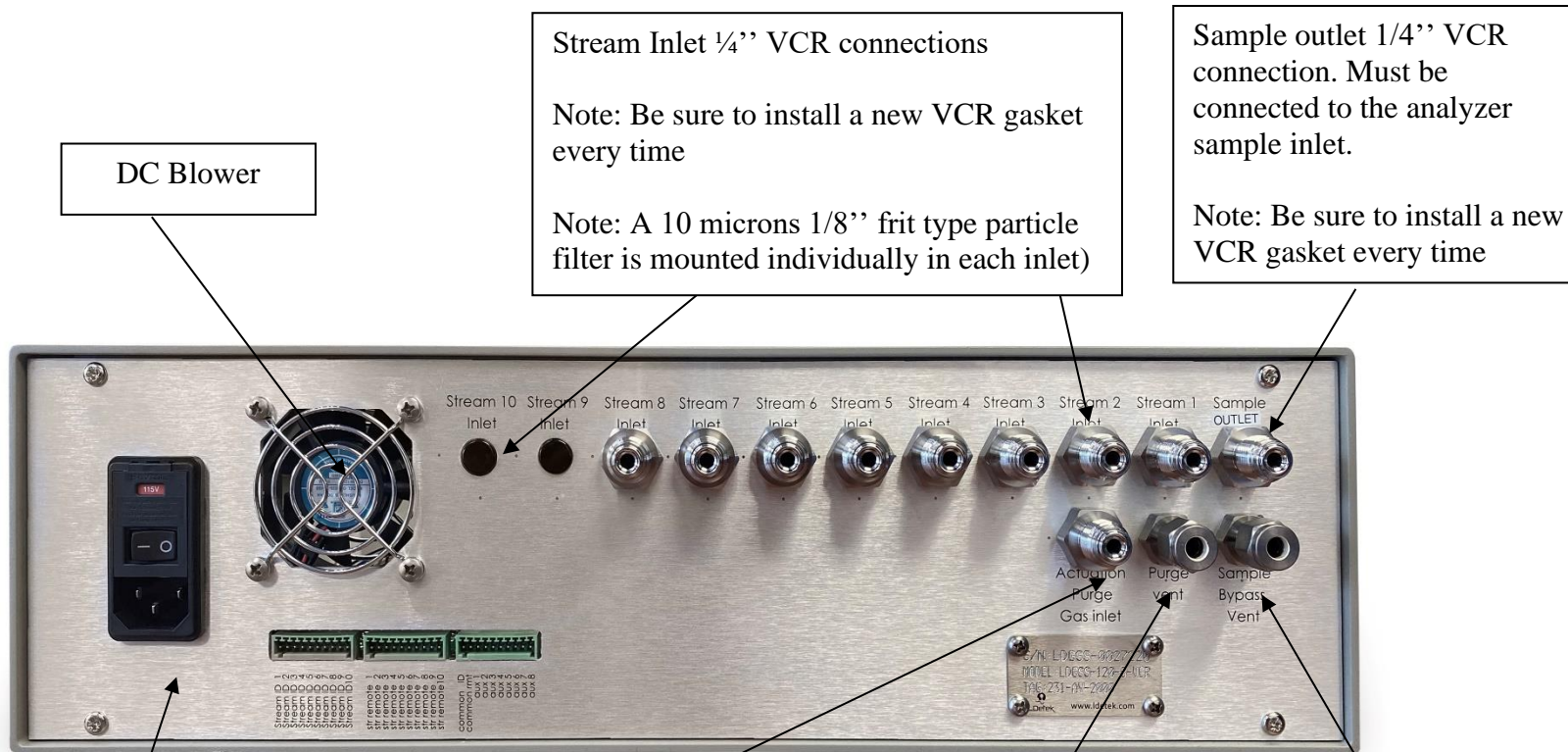

DC Blower

Stream Inlet 1/4" VCR connections

Note: Be sure to install a new VCR gasket every time

Note: A 10 microns 1/8" frit type particle filter is mounted individually in each inlet

Sample outlet 1/4" VCR connection. Must be connected to the analyzer sample inlet.

Note: Be sure to install a new VCR gasket every time

Power Inlet switch module & fuses.
+
Voltage indicator (user's selectable)

Actuation purge gas inlet:

- For the diaphragm valve version, a pneumatic actuation is required which is set at 65 psig internally to the LDGSS with a pressure regulator. Supply pressure 65-100psig is required at the gas connection. Gas source is the same as the GC

Purge Vent:

- Comes from the internal purge of the Stainless-Steel valve in the diaphragm valve version.
- Comes from the unselected streams in the 3 ways valve version.
- Purge flow is adjusted from the front panel adjustable

Sample bypass Vent:

- Sample bypass flow is adjusted from the front panel adjustable valves.
- The flow is adjustable individually and the sample bypass vent is the total of all bypass vents together.

9.2 Front Panel Identification

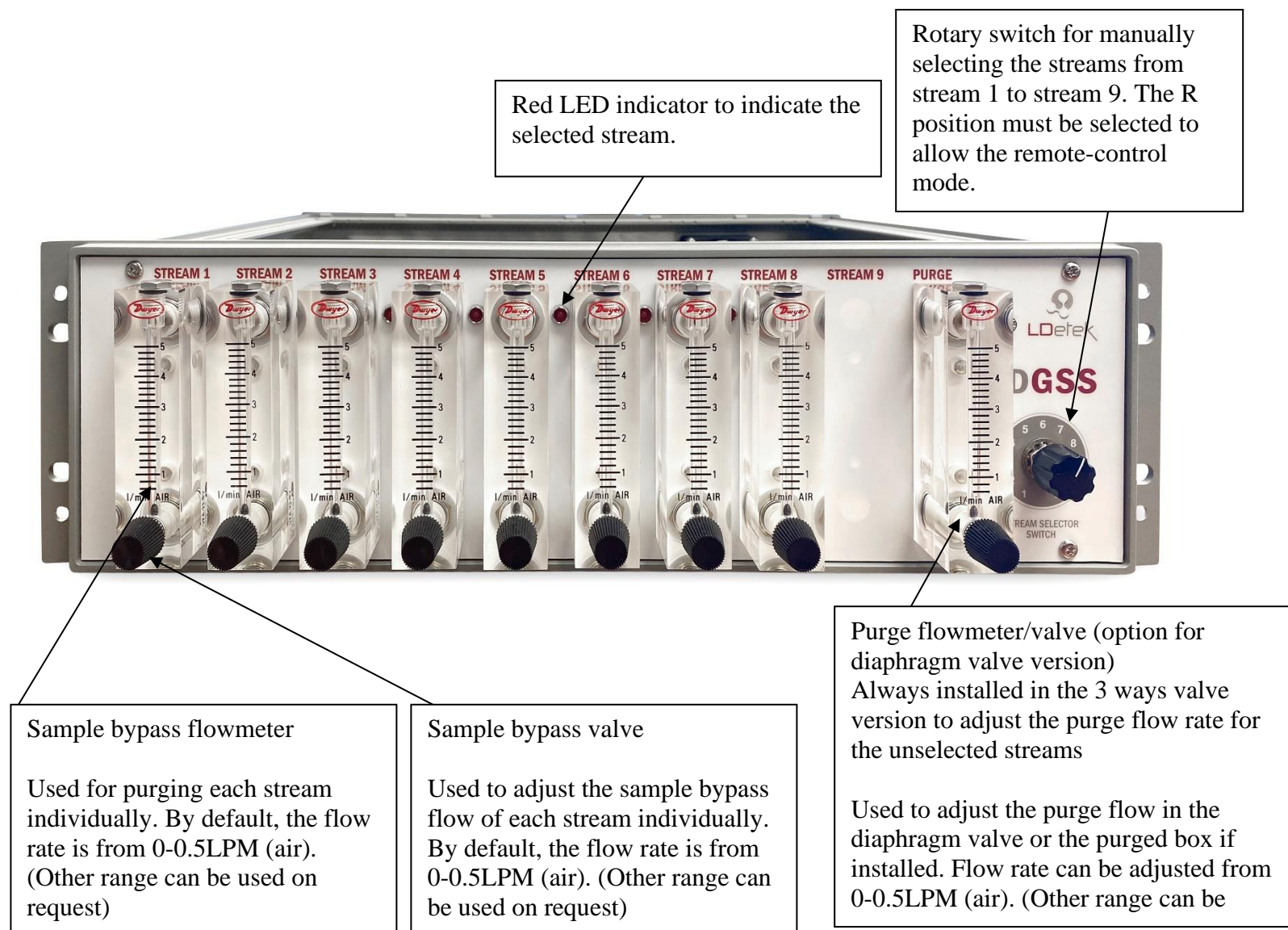

9.3 Internal parts identification (version 3 ways solenoid valve, 8 streams)

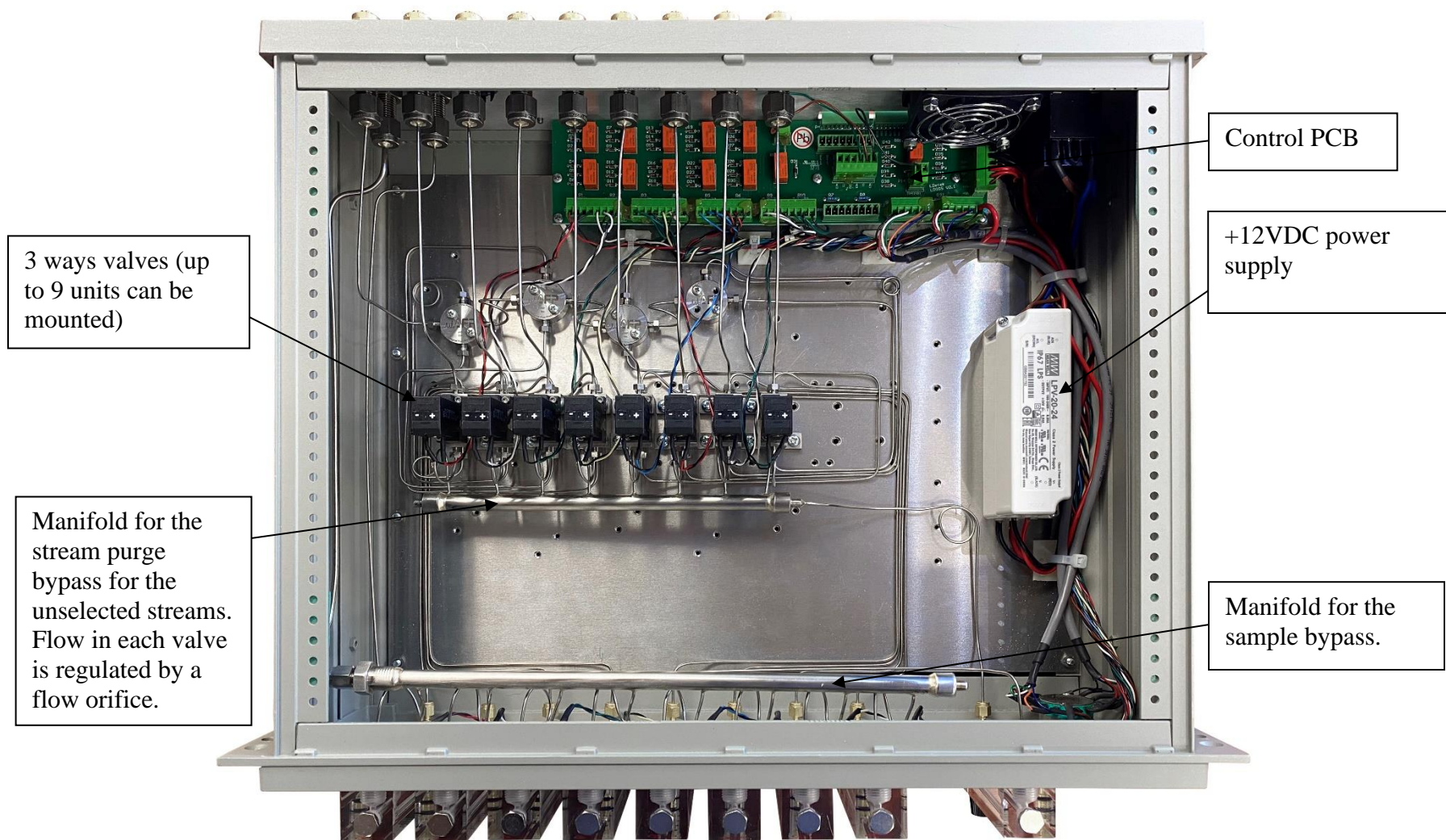

9.4 Internal part identification (version diaphragm's valve, pneumatic actuation, 8 streams)

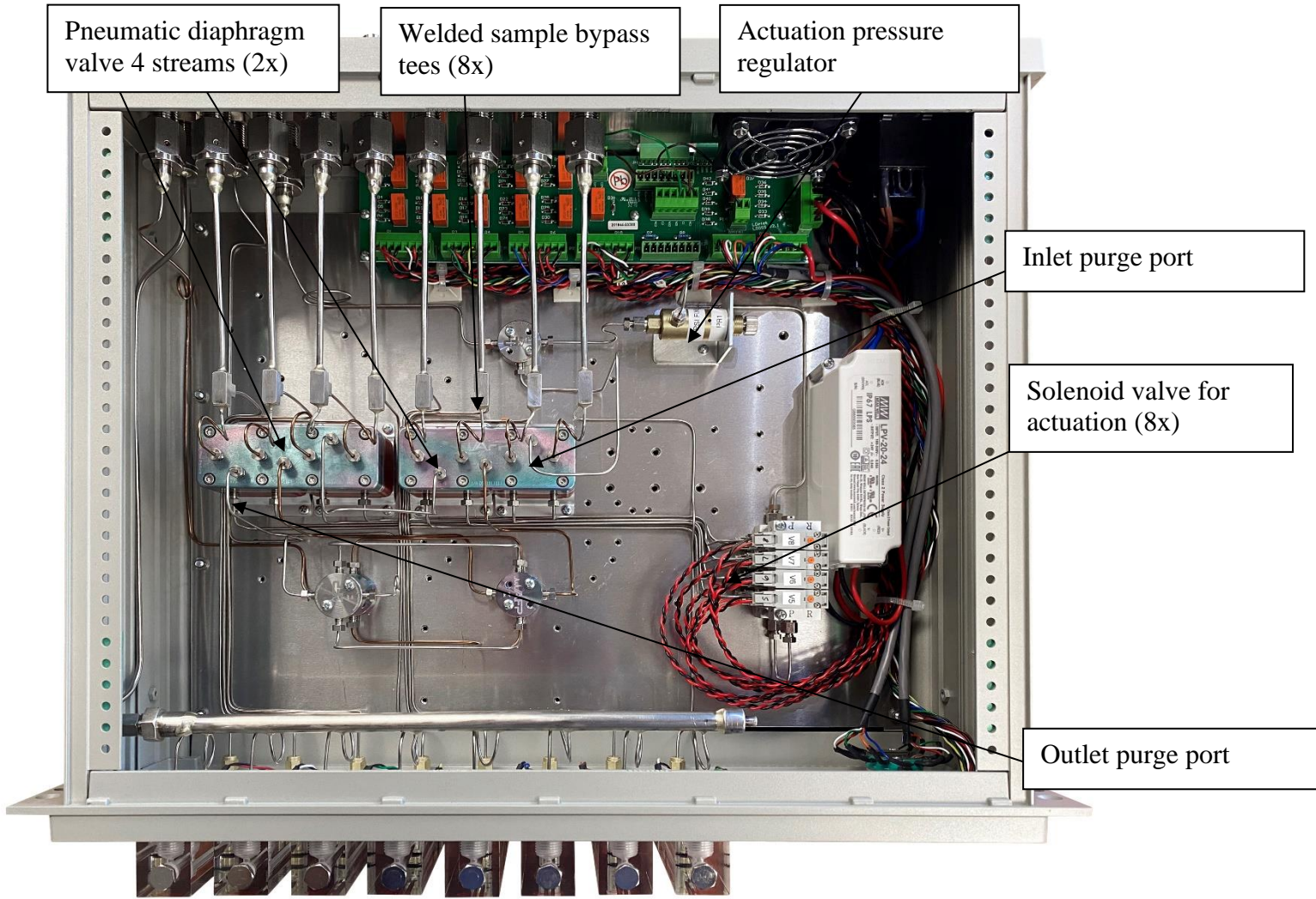

9.5 Cabinet dimensions

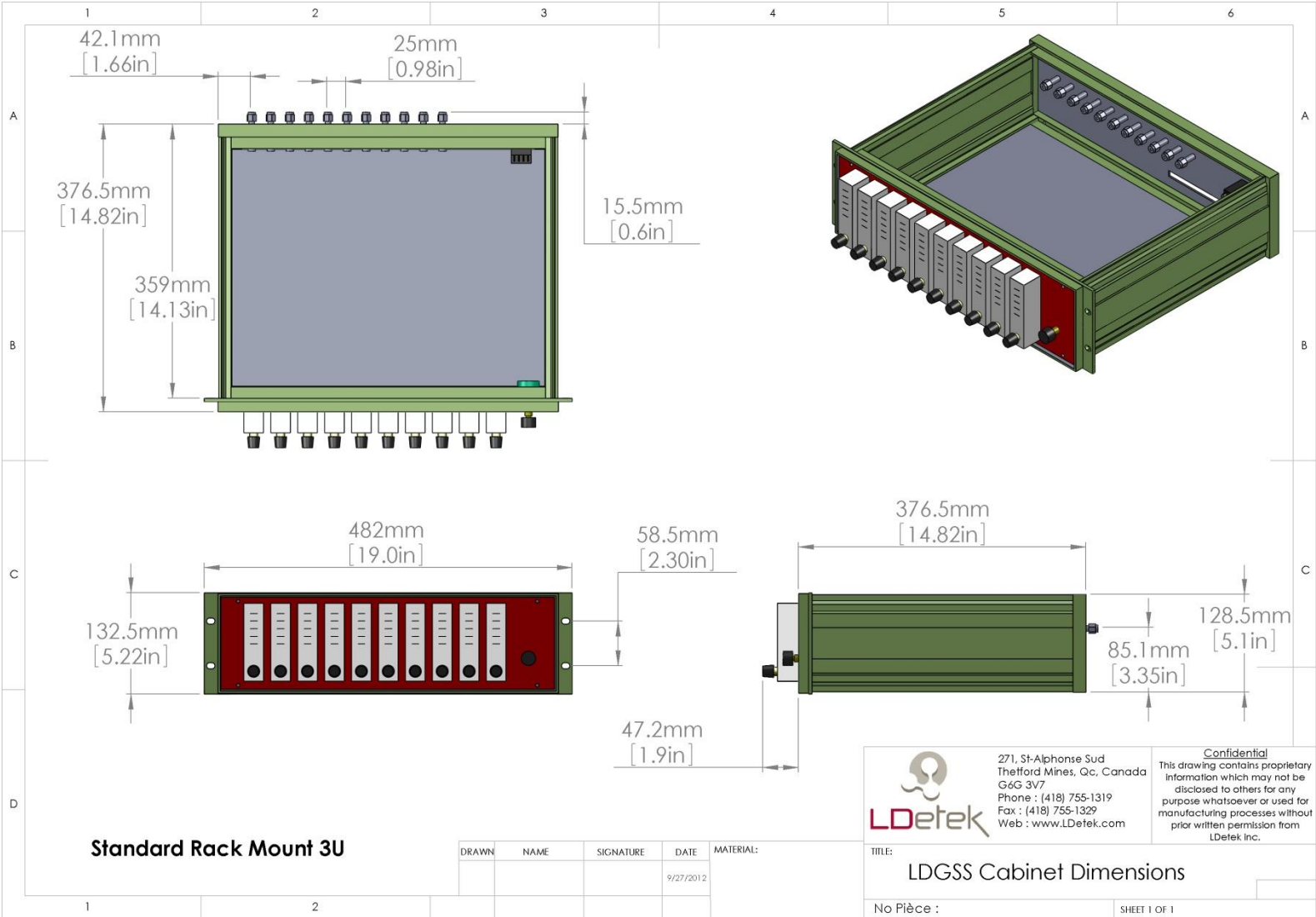

9.6 Internal schematic with 3 ways electric valve (8 streams)

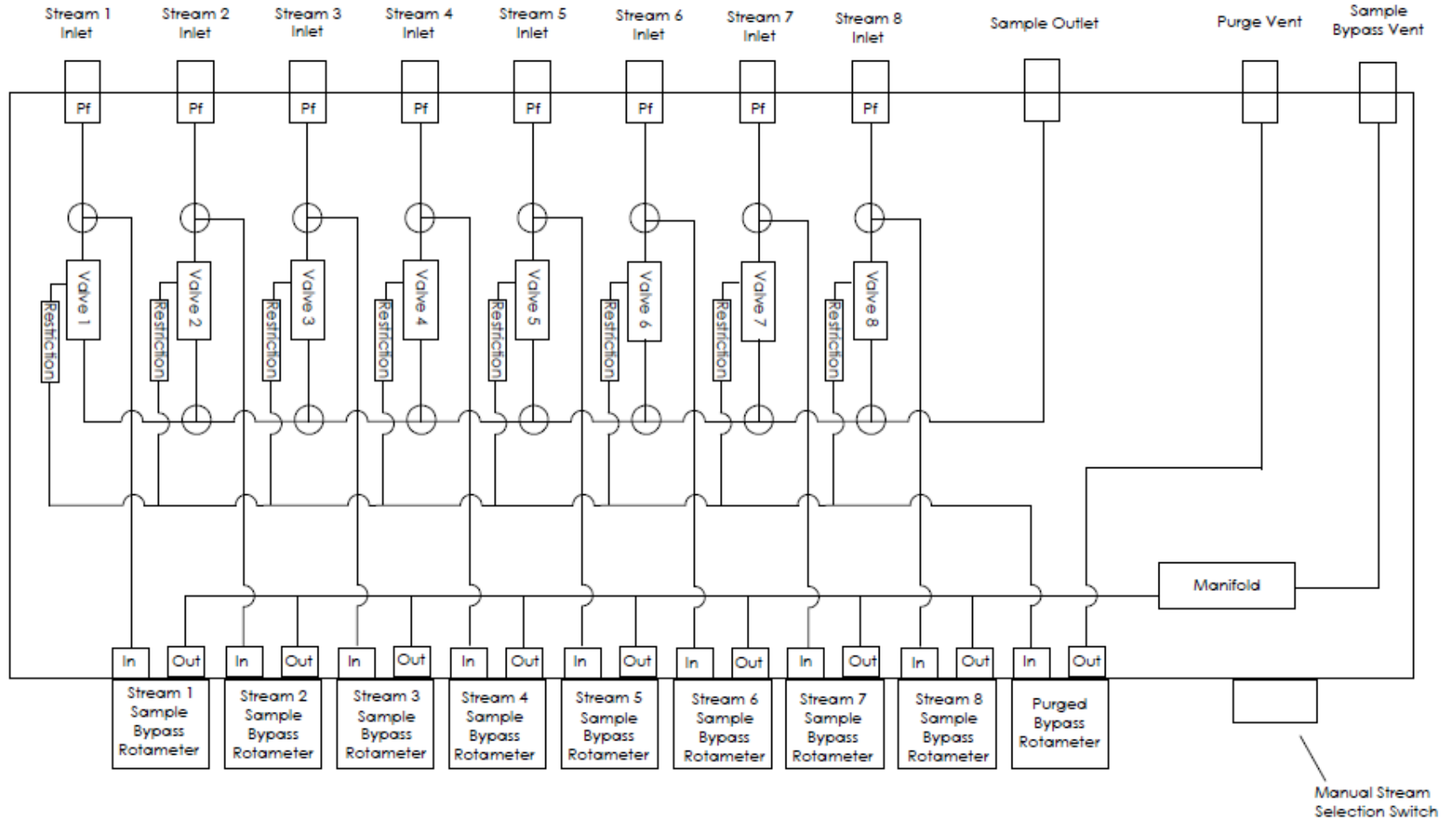

Pf = Particle filter (inserted frit model)

9.7 Internal schematic with pneumatic diaphragm valve (10 streams)

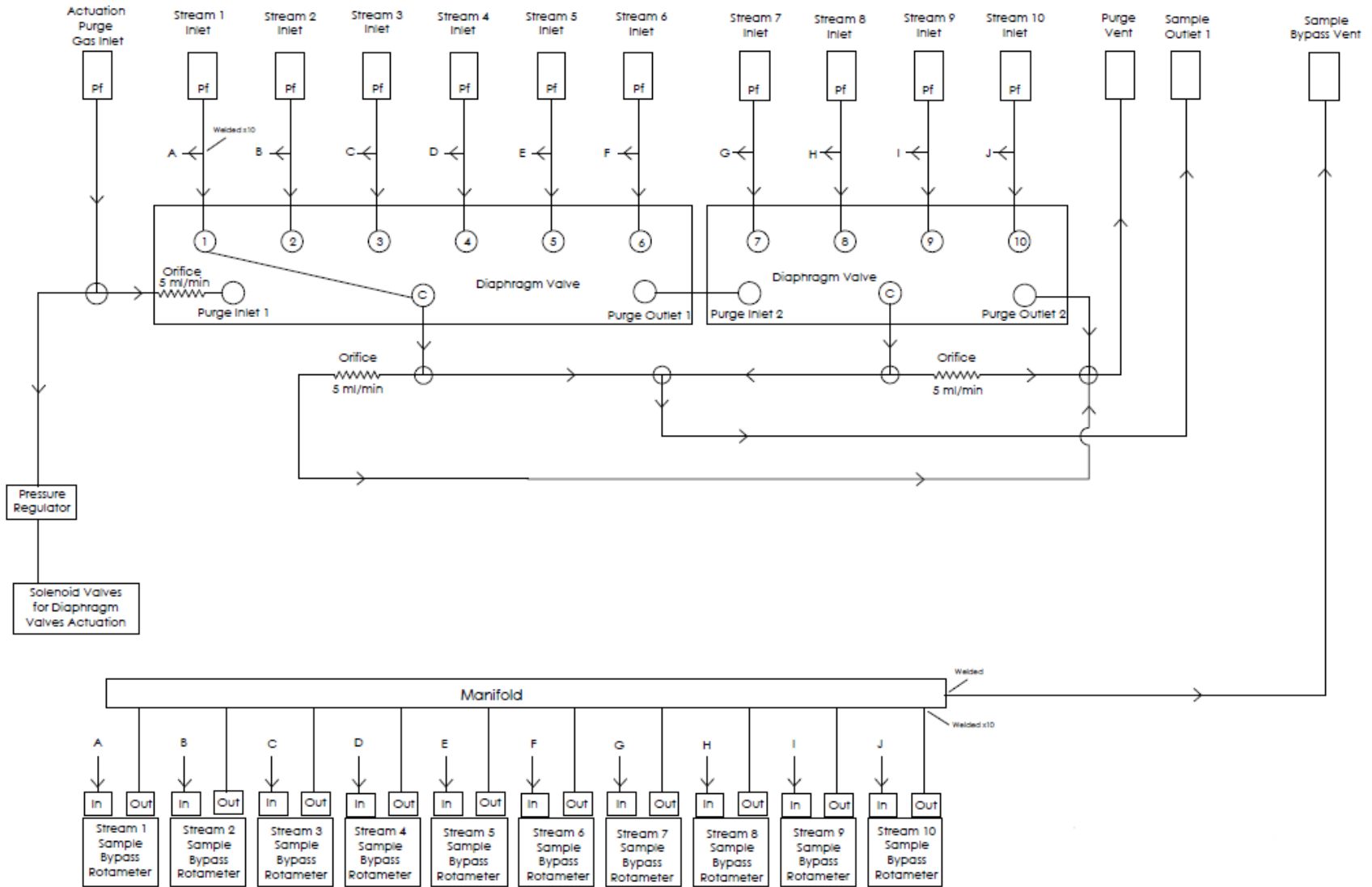

Pf = Particle filter (inserted frit model)

9.8 Internal schematic with pneumatic diaphragm valve double block and bleed (6 streams)

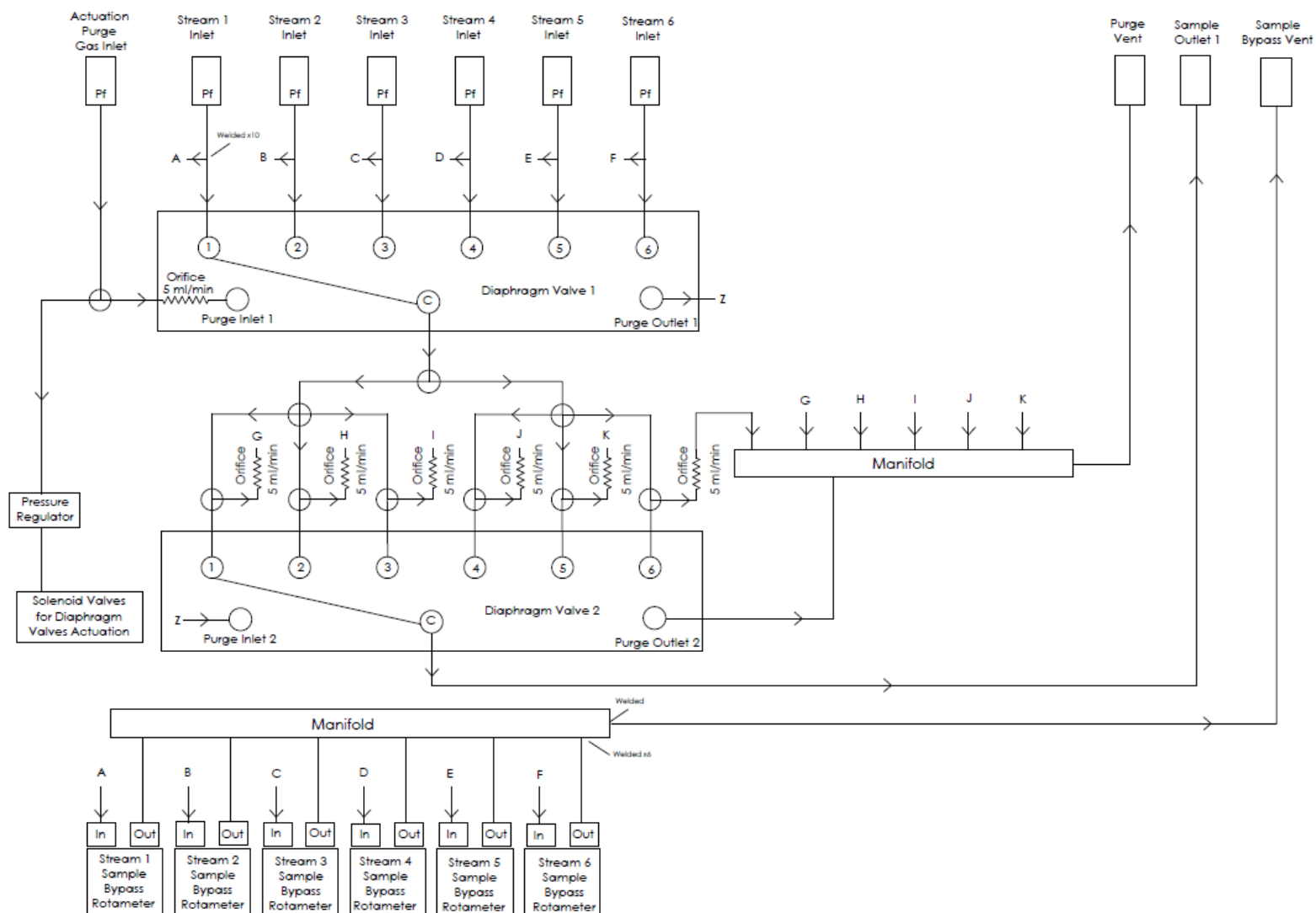

Pf = Particle filter (inserted frit model)

10. Ordering information

LDGSS	-XXX	-X	-X/X	-XXX	-X	-XXX
	Operating Voltage	Number of inlets	Gas inlets connections size	Gas inlets type	Valve type	Options
	120 Volts (-120) 220 Volts (-220)	2 to 10 : 2 to 10 streams	1/16 : 1/16 inches 1/8 : 1/8 inches 1/4 : 1/4 inches	VCR : face seal type SWG : compression type	P : Pneumatic E : Electric	BPR : Sample outlet back pressure regulator VPB : Valves purge box PG : Purging gas flowmeter/valve on front panel PR : Stream inlet pressure regulator C : Coated flow path for corrosive and absorbent gases MBP : Metal bellow pump for low pressure application O2 : Oxygen clean certified for Oxygen service DBB : Double block and bleed

10.1 Options

BRP:

A back pressure regulator can be mounted on the sample outlet of the LDGSS to regulate the outlet pressure at a fixed pressure.

VPB:

A valve purged box can be added for hazardous applications. When hazardous gases are used in the LDGSS and the area where the LDGSS is used is not ventilated, the purged box is necessary to avoid explosion and any other kind of hazardous situation

PG:

A purging gas inlet flowmeter/valve can be added to the LDGSS front panel when an external source of inert gas is required for purging the diaphragm version of the valves. This is for ultra high purity applications or for hazardous gases.

PR:

A pressure regulator can be added in line with a stream to reduce the operating pressure.

C:

Different versions of coating can be used depending of the type of gases. The coating is used for corrosive and/or absorbent gases

MBP:

Metal bellows pump for low pressure application to increase the stream pressure in the working range of the LDGSS.

O2:

Oxygen clean certified for Oxygen service.

DBB: Double block and bleed

Ask LDetek to have more details about ordering information for these options

Thanks for using LDetek Products



Where **innovation** leads to **success**

271 St-Alphonse Sud, Thetford Mines, (Qc), Canada, G6G 3V7
Phone: 418 755-1319 • Fax: 418 755-1329 • info@ldetek.com www.ldetek.com

©Copyright 2013 LDetek inc.

PRINTED IN CANADA