



# LDGDSA

## USER'S MANUAL

GAS DILUTION SYSTEM



***LDGDSA***

**Gas Dilution System**

**USER'S MANUAL**  
V1.4

Printed in Canada  
Copyright 2020



---

---

## Table of Content

1. Forwarning.....	5
2. Warranty, maintenance and service policies.....	6
3. Cautions & Warnings .....	9
3.1 Electrical shock hazard .....	9
3.2 Possible explosion hazard .....	9
4. Specifications .....	10
5. Installation .....	11
5.1 Installation with a MultiDetek2 .....	11
5.1.1 Connection to LDChroma .....	11
5.2 Standalone Installation .....	14
5.2.1 Connection to LDChroma (Standalone).....	15
5.2.2 Import a configuration file.....	16
6. Hardware description .....	18
6.1. Zero and Span pneumatic shut off valves .....	18
6.2. Electronic pressure controllers.....	18
6.3. MCU .....	18
6.4. Solenoid valves .....	18
6.5. Orifices.....	18
6.6. Integrated gas purifier (Compact-LDP1000).....	19
6.7. Optional diaphragm valves for zero and span selection .....	19
7. Software interface .....	20
7.1 Settings menu .....	20
7.2 Chromatogram menu.....	21
7.3 Diagnostic menu.....	22
8.0 Drawings & Schematics.....	25
8.1. Piping diagram.....	25
8.2. Dimensions & cutout.....	26
8.3. Internal view .....	27
8.4. Back Panel view.....	28
8.5. Front panel view .....	29
8.6. Internal view with options 2 inlets for zero/span with dual purifiers .....	30
8.7. Piping diagram with options 2 inlets for zero/span with dual purifiers.....	31
9. Ordering information.....	32
10. Maintenance .....	33
10.1 Spare part list .....	33
10.2 Frequently asked questions .....	33



## Table of Figures

Figure 1: LDGDSA Alert .....	12
Figure 2: Serial cable connection.....	13
Figure 3: LDGDS communication settings .....	14
Figure 4: LDGDS communication settings (standalone).....	15
Figure 5: Download/Upload LDGDS Settings .....	16
Figure 6: LDGDS Import Settings.....	17
Figure 7: LDGDS Settings menu.....	21
Figure 8: Chromatogram menu.....	22
Figure 9: LDGDS diagnostic menu .....	23



## 1. Forwarning

This manual is required to be read by any user wanted to use the LDGDSA Gas Dilution System. It contains important information to successfully operate the instrument. LDetek makes assumption that all operators have taken the time to read this information prior to install, operate and troubleshoot the system.

If any error is suspected by the reader, please contact LDetek. LDetek reserves the right to make changes to subsequent editions of this document without prior notice to holders of this edition.

We want to thank you to choose LDetek.

## 2. Warranty, maintenance and service policies

Goods and part(s) (excluding consumable) manufactured by Seller are warranted to be free from defects in workmanship and material under normal use and service for a period of **twelve (12)** months after installation and start up and not exceeding **18 months** from shipment date. Consumable, chemical trap, O-rings, etc., are warranted to be free from defects in workmanship and material under normal use and service for a period of ninety (90) days from date of shipment by Seller. Goods, part(s) proven by Seller to be defective in workmanship and/or material shall be replaced or repaired, free of charge, F.O.B. Seller's factory provided that the goods, part(s) are returned to Seller's designated factory, transportation charges prepaid, within the twelve (12) months after installation and start up and not exceeding 18 months from shipment date. In the case of consumable; within the ninety (90) days period of warranty. A defect in goods, part(s) and consumable of the commercial unit shall not operate to condemn such commercial unit when such goods, part(s) and consumable are capable of being renewed, repaired or replaced.

The Seller shall not be liable to the Buyer, or to any other person, for the loss or damage directly or indirectly, arising from the use of the equipment of goods, from breach of any warranty, or from any other cause. **All other warranties expressed or implied are hereby excluded.**

IN CONSIDERATION OF THE HEREIN STATED PURCHASE PRICE OF THE GOODS, SELLER GRANTS ONLY THE ABOVE STATED EXPRESS WARRANTY. NO OTHER WARRANTIES ARE GRANTED INCLUDING, BUT NOT LIMITED TO, EXPRESS AND IMPLIED WARRANTIES OF MERCHANTABILITY AND FITNESS FOR A PARTICULAR PURPOSE.

THIS WARRANTY IS THE ONLY WARRANTY MADE BY LDETEK INC. WITH RESPECT TO THE GOODS DELIVERED HEREUNDER, AND NO EMPLOYEE, REPRESENTATIVE OR OTHER PERSON OR ENTITY IS AUTHORIZED TO ASSUME FOR LDETEK INC ANY OBLIGATION OR LIABILITY BEYOND OR AT VARIANCE WITH THIS WARRANTY IN CONNECTION WITH THE SALE OF LDETEK PRODUCTS.

**Limitations of Remedy.** SELLER SHALL NOT BE LIABLE FOR DAMAGES CAUSED BY DELAY IN PERFORMANCE. THE SOLE AND EXCLUSIVE REMEDY FOR BREACH OF WARRANTY SHALL BE LIMITED TO REPAIR OR REPLACEMENT UNDER THE STANDARD WARRANTY CLAUSE. IN NO CASE, REGARDLESS OF THE FORM OF THE CAUSE OF ACTION, SHALL SELLER'S LIABILITY EXCEED THE PRICE TO BUYER OF THE SPECIFIC GOODS MANUFACTURED BY SELLER GIVING RISE TO THE CAUSE OF ACTION. BUYER AGREES THAT IN NO EVENT SHALL SELLER'S LIABILITY EXTEND TO INCLUDE INCIDENTAL OR CONSEQUENTIAL DAMAGES. CONSEQUENTIAL DAMAGES SHALL INCLUDE BUT ARE NOT LIMITED TO, LOSS OF ANTICIPATED PROFITS, LOSS OF USE, LOSS OF REVENUE, COST OF CAPITAL AND DAMAGE OR LOSS OF OTHER PROPERTY OR EQUIPMENT. IN NO EVENT SHALL SELLER BE LIABLE FOR PROPERTY DAMAGE AND/OR THIRD PARTY CLAIMS COVERED BY UMBRELLA INSURANCE AND/OR INDEMNITY COVERAGE PROVIDED TO BUYER, ITS ASSIGNS, AND EACH SUCCESSOR INTEREST TO THE GOODS PROVIDED HERE UNDER.

**Major force.** Seller is not liable for failure to perform due to labor strikes or acts beyond Seller's direct control.

### **SERVICE POLICY**

1. If a product should fail during the warranty period, it will be repaired free of charge. For out of warranty repairs, the customer will be invoiced for repair charges at current standard labor and materials rates.
2. Customers who return products for repairs, within the warranty period, and the product is found to be free of defect, may be liable for the minimum current repair charge.
3. For parts replacement, the original part must be returned with serial and model numbers of the system. **NO PART WILL BE SHIPPED IF THE ORIGINAL IS NOT SENT BACK TO LDETEK INC.**



## RETURNING A PRODUCT FOR REPAIR

Upon determining that repair services are required, the customer must:

1. Obtain an RMA (Return Material Authorization) number.
2. Supply a purchase order number or other acceptable information.
3. Include a list of problems encountered along with name, address and telephone, and RMA number.
4. **Ship the system in its original crating or equivalent. Failure to properly package the system will automatically void the warranty.**
5. **Every gas connection must be capped with appropriate metal caps. Failure to do so will automatically void the warranty.**
6. Write RMA number on the outside of the box.
7. Use a LDetek approved carrier. Also, the delivery must be sent to LDetek facilities. LDetek will not accept airport to airport delivery.
8. LDetek will not cover transport fees.

Other conditions and limitations may apply to international shipments.

## PROPRIETARY RIGHTS

Buyer agrees that any LDetek's software, firmware and hardware products ordered or included in the goods ordered are proprietary of LDetek. No change, modification, defacement, alteration, reverse engineering, software decompilations nor reproduction of such software or hardware products, or disclosures of programming content to other parties is authorized without the express written consent of LDetek.

To maintain LDetek trade secret and other proprietary protection of such software and firmware, such items are not sold hereunder but are licensed to buyer.

LDetek Inc. reserves the right to interrupt all business relationship and warranty or service if there is any tentative from any customers to reverse engineering any of LDetek products or to tamper with any sealed module.

Trademarks and product identification as LDGDSA are the property of LDetek Inc. and shall be used only in connection with LDetek's products. No third party could remove or deface any model number or marks.



### 3. Cautions & Warnings

Improper installation, operation or service of this analyzer may cause damage to the analyzer and void the manufacturer's warranty.

#### 3.1 *Electrical shock hazard*

**Do not operate unless the cabinet is securely closed. Servicing this instrument implies possible exposure to shock hazard level voltages which can cause death or serious injury.**

For both safety and proper performance, this instrument **must** be connected to a properly grounded three-wire source of electrical power.

Both alarm switching relay contacts and digital output contacts wired to a separate power source must be disconnected before servicing.

Tampering or unauthorized substitution of components may adversely affect the safety of this product. Use only factory-approved components for repair.

#### 3.2 *Possible explosion hazard*



**Never introduce hydrogen and oxygen in the same system. LDetek isn't responsible if hydrogen and oxygen source is mixed in the same system. LDetek policy is to separate oxygen and hydrogen using two distinct system used in two separate areas.**

**With the use of any type of hazardous gases in the LDGDSA, it is necessary to have the LDGDSA system installed in a ventilated area. If the LDGDSA can't be installed in a well-ventilated area, it is then necessary to have the purge option installed in the LDGDSA.**

**It is the responsibility of the client to advise LDetek about the use and installation environment where will work the LDGDSA.**

This analyzer must be installed in laboratory environments: moisture- and vibration-free, with stable temperatures.

## 4. Specifications

<b>Flow controllers:</b>	Electronic flow controllers
<b>Dilution Ratios:</b>	0 – 10 0 – 100 0 – 1000 other ratios possible on request
<b>Repeatability:</b>	< 1%
<b>Accuracy:</b>	Better than $\pm 1\%$
<b>Options:</b>	1 or 2 heated gas purifiers for zero gas reference(s) 2 streams for choice between 2 types of zero gas 2 streams for choice between 2 types of span gas
<b>Gas connections:</b>	Inlets/Outlets: 1/8" compression fittings (Swagelok type) 1/4" compression fittings (Swagelok type) 1/8" VCR fittings (Swagelok type) 1/4" VCR fittings (Swagelok type)  Vents: 1/8" compression fitting (Swagelok type)
<b>Recommended maximum operating pressure:</b>	100 PSIG (6.89 Bar)
<b>Recommended minimum operating pressure:</b>	10 PSIG (0.7 Bar)
<b>Operating temperature:</b>	10 °C to 50 °C
<b>Supply:</b>	115 VAC, 50 – 60 Hz or 220 VAC, 50 – 60 Hz
<b>Power consumption:</b>	Maximum 20 watts Maximum 70 watts with optional integrated heated gas purifier
<b>Drift:</b>	< $\pm 1\%$ over 24 hours
<b>Weight:</b>	16 lbs (13 kg)

## 5. Installation

### 5.1 Installation with a MultiDetek2

Some simple steps are required to make a successful installation.

1. Unpack the instrument from the box carefully.
2. Remove the plugs on the backplate.
3. Purge every gas line before to connect to the LDGDSA gas inlet connections to avoid any liquids, dust, contaminants going to the LDGDSA piping. A 10micron particle filter is installed at every gas inlet port to avoid contamination of the internal parts.
4. Connect each gas line to the appropriate gas source. **For VCR version, be sure to use a new gasket.**
5. Connect the blended outlet of the LDGDSA to the analyzer. **For VCR version, be sure to use a new gasket.**
6. Be sure the vent connections of the LDGDSA is left to the atmosphere.
7. Put Power on the unit.
8. Make sure the RS232 or the ethernet cable is connected to ensure remote control of the unit.

#### 5.1.1 Connection to LDChroma

Once the LDGDSA is connected to the appropriate gas sources and power on, you can open LDChroma to confirm that it is communicating with the MultiDetek2. LDChroma should already be configured with the right setting for the LDGDSA. In case there is a communication issue, an alert will be generated. As shown in the following picture, you will be able to see it in the right section of the bottom bar on the chromatogram menu. To have more details about the alert, you can double-click on the bottom bar to open the Alert menu.

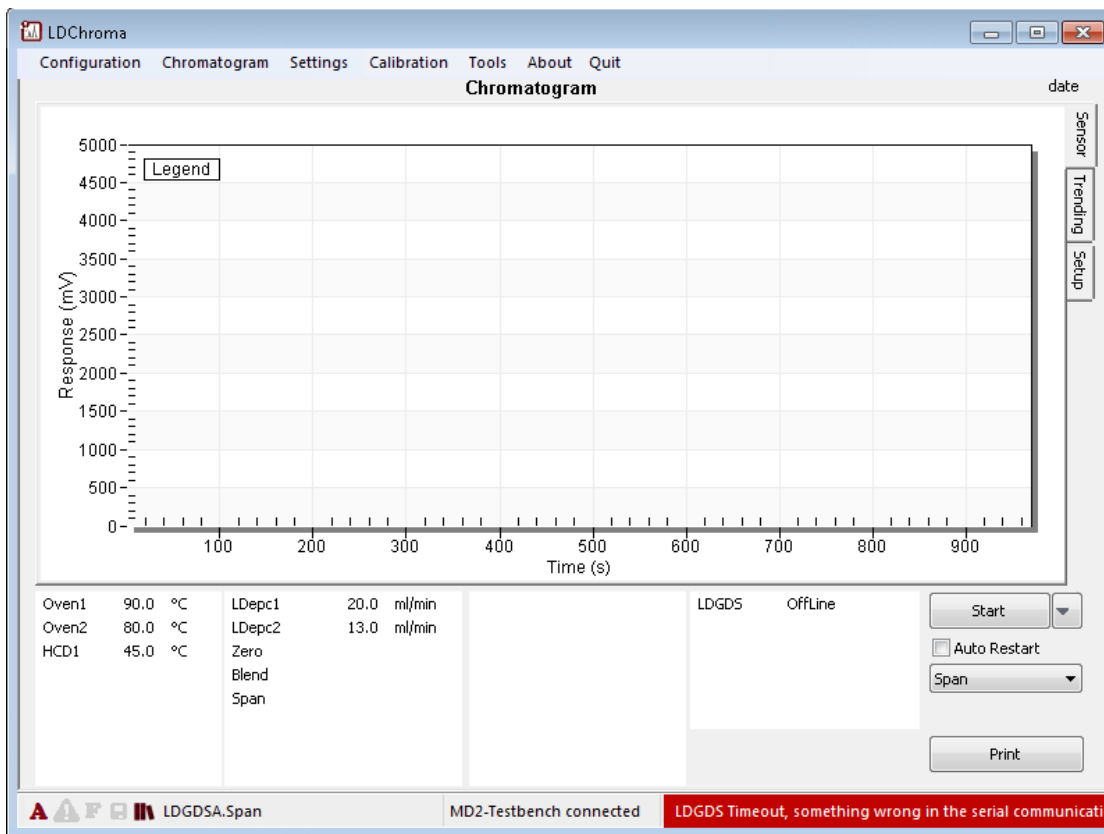

Figure 1: LDGDSA Alert

If you encounter this alert, the following step will help you resolve it:

- 1- Make sure that the LDGDSA is powered ON using the power switch at the back of the unit.
- 2- Make sure that the serial cable is well connected at the back of the LDGDSA.
- 3- Make sure that the serial cable is well connected at the back of the MultiDetek2.
- 4- Make sure that the serial cable is well connected to the panel PC. To do so, open the front door of the MultiDetek2 using the black push button. As shown in the following picture, the serial cable should be connected to the right serial port.



**Figure 2: Serial cable connection**

- 5- Make sure that settings are well configured in the setting menu. To verify this, go to Setting>>Settings>>LDGDS. Then, double-click on “Serial port” to open the serial settings. The following picture shows the setting that should be entered for a typical system.



Figure 3: LDGDS communication settings

Once the communication restored, the alert “LDGDS Timeout” will disappear. In the event the above steps do not solve the issue, then it is required to contact LDeTek support for further instructions.

## 5.2 Standalone Installation

Some simple steps are required to make a successful installation.

1. Unpack the instrument from the box carefully.
2. Remove the plugs on the backplate.
3. Purge every gas line before to connect to the LDGDSA gas inlet connections to avoid any liquids, dust, contaminants going to the LDGDSA piping. A 10micron particle filter is installed at every gas inlet port to avoid contamination of the internal parts.
4. Connect each gas line to the appropriate gas source. **For VCR version, be sure to use a new gasket.**
5. Connect the blended outlet of the LDGDSA to the analyzer. **For VCR version, be sure to use a new gasket.**
6. Be sure the vent connections of the LDGDSA is left to the atmosphere.
7. Put Power on the unit.
8. Make sure the RS232 cable is connected to ensure remote control of the unit.

### 5.2.1 Connection to LDChroma (Standalone)

Once the LDGDSA is connected to the appropriate gas sources and power on, it can now be connected to the computer using the RS232 cable. LDChroma must be installed on the computer in order to control the LDGDS. The installation file of LDChroma is on the USB drive provided with the unit.

Once LDChroma installed, you can open it to configure the communication with the LDGDSA. To configure the communication, the below steps can be followed:

1. Open LDChroma and go to Settings>>Settings>>LDGDS
2. Under the section “Block A”, double-click on the row “type”, select “Automatic” and click on “OK”.
3. Then, double on the row “Serial” to configure the communication.
  - a. Tick the checkbox “Enable”
  - b. Select the port on which the LDGDSA is connected
  - c. The baud rate must be set to “57600”
  - d. The polarity must be set to “None”
  - e. Data bits must be set to “8”
  - f. Stop bit must be set to “1”

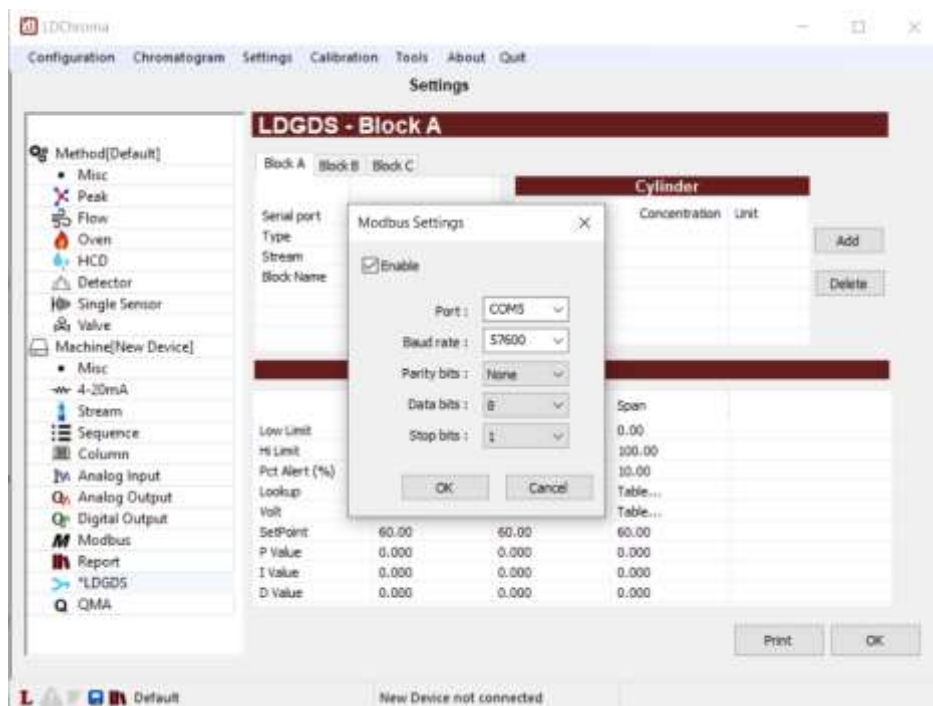

Figure 4: LDGDS communication settings (standalone)

4. Once done, click on “OK” to close the window and click on “OK” from the setting menu (beside the print button).
5. After a few seconds, LDChroma will ask you if you want to upload the data from the LDGDSA or if you want to download data to the LDGDSA. The most convenient option is to upload the data from the LDGDSA. To do that, click on “LDGDA -> LDChroma”. After a few seconds, the data will be updated, and the window will close.

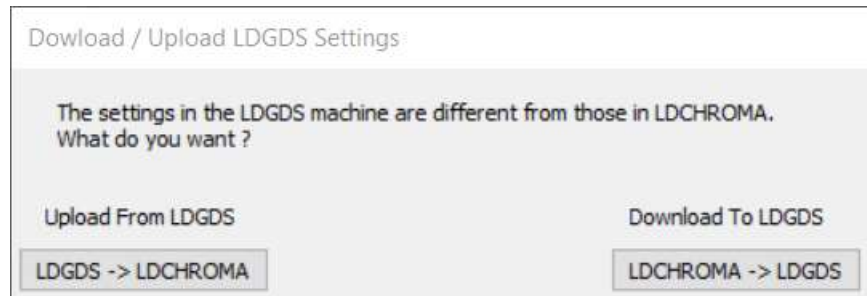

Figure 5: Download/Upload LDGDS Settings

If you encounter the alert “LDGDS, Timeout”, the following step will help you resolve it:

- 1- Make sure that the LDGDSA is powered ON using the power switch at the back of the unit.
- 2- Make sure that the serial cable is well connected at the back of the LDGDSA.
- 3- Make sure that the serial cable is well connected to your computer
- 4- Make sure that the serial settings are well configured and that the right port is selected.

In the event the above steps do not solve the issue, then it is required to contact LDetek support for further instructions.

### **5.2.2 Import a configuration file**

On the USB drive, there is an XML file that contains all the settings of the LDGDSA, and you can use it as a backup. To import it into LDChroma, you must go to Settings>>Settings. Then, right-click on “LDGDS” to open the context menu as shown in the below picture.



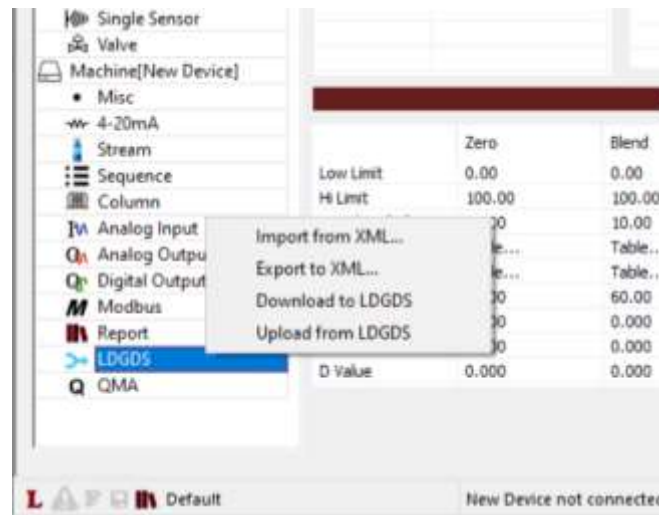

Figure 6: LDGDS Import Settings

By clicking on “Import from XML”, you will be allowed to select the XML file to import the data. You can then click on “Download to LDGDS” to send the data to the dilution system. If you want to create a backup, you can click on “Export XML” to generate an XML file.

## 6. Hardware description

This section will describe the main components. Refer to the internal view section of this manual to identify the parts.

### **6.1. Zero and Span pneumatic shut off valves**

Two high purity stainless steel pneumatic diaphragm type valves are used to shut off the zero and span gases in order to save gas consumption when the system isn't used.

### **6.2. Electronic pressure controllers**

Three high purity stainless steel electronic pressure regulators are used to control the pressure rate for each of the zero, the span and the blended outlet. Each electronic pressure controller module has its own proportional valve and pressure sensor.

It is essential that the blended outlet pressure is stable at its setpoint value to ensure accuracy of the mixture. The flow tables have been certified using a fixed blended outlet pressure value. By default, this value is 10psig, but can be changed depending of the application. The settings can all be changed from the remote interface.

### **6.3. MCU**

The MCU circuit is controlled from a RS232 communication port with an external computer. The LDGDSA software interface must be used to monitor and control the unit.

### **6.4. Solenoid valves**

Two solenoid valves are used to actuate the shut off valves.

### **6.5. Orifices**

A certified laser "VCR" gasket style 1/8"OD stainless steel is used for each zero and span to ensure an accurate/precise flow rate with no variation in time.

### **6.6. Integrated gas purifier (Compact-LDP1000)**

An integrated compact heated gas purifier is used as option to generate an ultra-clean zero gas certified for less than 10ppb total impurities. A version for noble gas or nitrogen or hydrogen is available depending of the requirements. An option for having 2 x integrated gas purifiers is available is more than one zero gas is required. Both units are integrated inside the same unit and are controlled from the interface.

### **6.7. Optional diaphragm valves for zero and span selection**

The option to have 2 x zero gases and 2 x span gases use our ultra-high purity purged diaphragm valve. The gas consumption can be shutoff when the unit is in standby mode by opening all ports of the valve. This for the zero and span gases. The selection of the proper stream can be selected from the interface and actuate the proper stream of the valves.

## 7. Software interface

The LDGDSA is controlled by our interface named LDChroma. It is installed on the 8-inch pannel PC (touch screen) provided with our MultiDetek2 which is working on Windows 10 embedded. However, it can be installed on any computer that is running Windows for stand-alone installation.

The following section shows the different tabs and menus used to operate the LDGDSA using LDChroma.

### 7.1 *Settings menu*

The settings menu contains all the parameters of the MultiDetek2 and the LDGDSA. Unless specified otherwise, **these parameters should not be changed without contacting LDetek support**. The available settings may vary depending on the software version. To update the software, **please contact LDetek support to ensure the versions are compatible with your system**.

In the settings menu, the section “LDGDS” contains all the parameters related to the LDGDSA. For operation, the only parameters that need to be changed are the ones in the section “Cylinder”. The concentration of the impurities from your calibration gas (COA) must be entered in this section. The LDGDSA will then use those values to adjust the flows and blend at the right concentration. For instance, the following picture shows that the calibration gas that is connected to the dilution system has 1050 ppb of CH<sub>4</sub>, 980 ppb of H<sub>2</sub> and 1010 ppb of N<sub>2</sub>. If the cylinder is replaced by another one, the values of all impurities must be updated. To do so, double-click on the value and enter the new concentration.

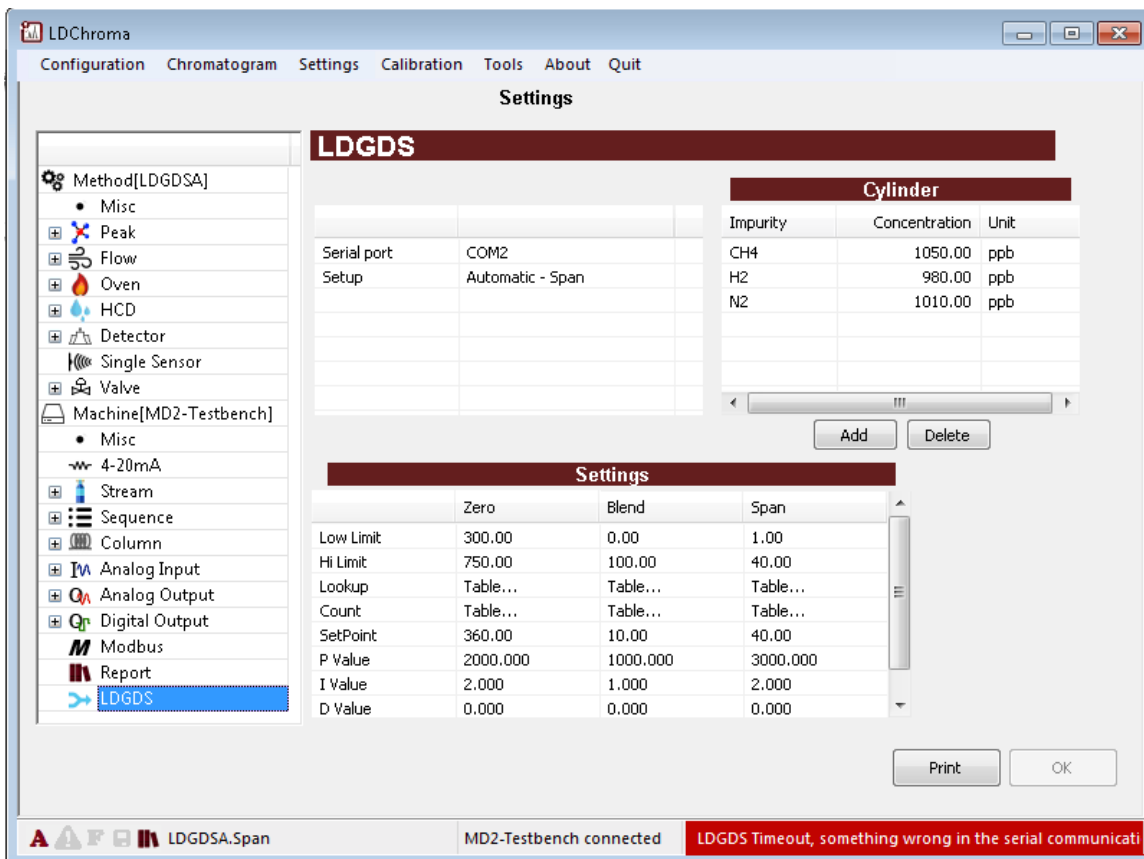

Figure 7: LDGDS Settings menu

## 7.2 Chromatogram menu

From the chromatogram menu, you can see the running chromatogram, the current results, the alerts, the oven temperature, the sample flow and the carrier flow. When an LDGDSA is connected to LDChroma, it can be controlled from this menu.

When the communication between the LDGDSA and LDChroma is established, the different flow (Zero, Span and Blend) will be displayed in the 2<sup>nd</sup> table. The value of the actual blend will be displayed in the 4<sup>th</sup> table.

In automatic mode, there is a stream associated with the LDGDSA. This stream is configured in the setting menu. When this stream is selected from the chromatogram menu, the LDGDSA will automatically open the zero and span shutoff valves. The unit will also adjust the flow in order to blend the span gas at the desired concentration. To edit the desired concentration, just double click on the impurity (from the 4<sup>th</sup> table) and enter the new concentration. The LDGDSA will automatically adjust the LDEPC to blend at the new value.

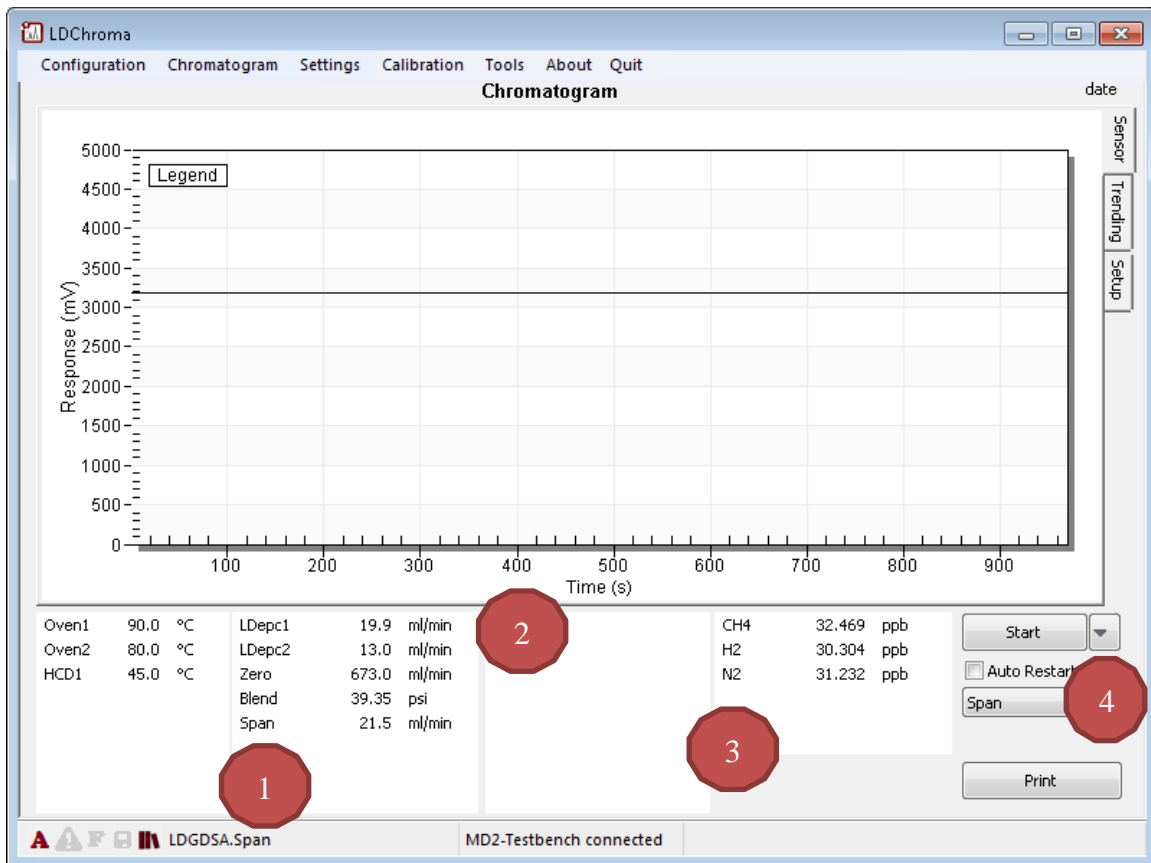

Figure 8: Chromatogram menu

- 1- Zero, Blend and Span flows are displayed in this section.
- 2- Result of the current analysis are displayed in this section.
- 3- Values of the actual blend are displayed in this section. To change the setpoint (blend value), double-click on a row and enter a new concentration. The LDGDSA will automatically adjust the flows to blend at the right value.
- 4- This context menu allows you to select the stream. In automatic mode, there is a stream associate with the LDGDSA. When this stream is selected, the shutoff valves will automatically open.

### 7.3 Diagnostic menu

The diagnostic menu can be accessed by clicking on Tools>>Diagnostics>> LDGDS. From that menu, you have access to all the parameters of the dilution system (e.g.

pressures, flows, voltages, etc.). This menu also allows you to force the value of parameters for diagnostic purposes.

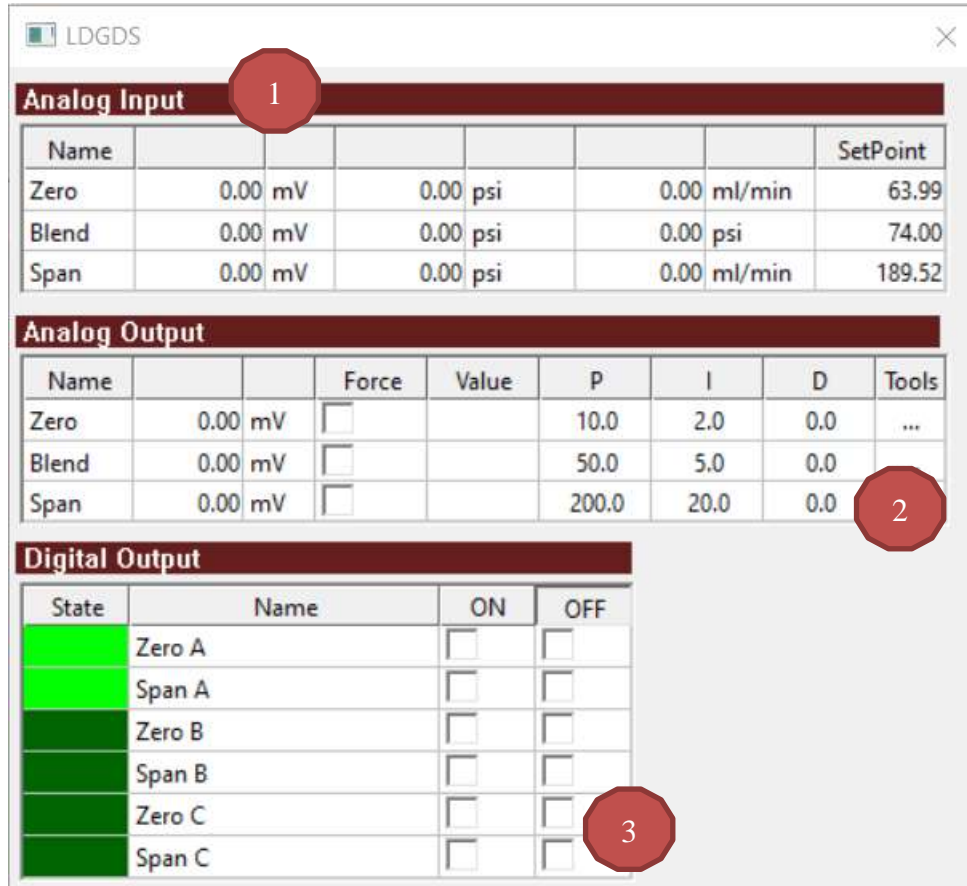

Figure 9: LDGDS diagnostic menu

- 1- In the section “Analog input”, you can monitor all the input signals (e.g. pressure and flow).
- 2- This section allows you to monitor or force the analog output signals (e.g. LD that controls zero, blend, and span pressure).
- 3- This section allows you to monitor and control the digital output signals (e.g. shutoff valves).

Drawings  
&  
Schematics



## 8.0 Drawings & Schematics

### 8.1. Piping diagram

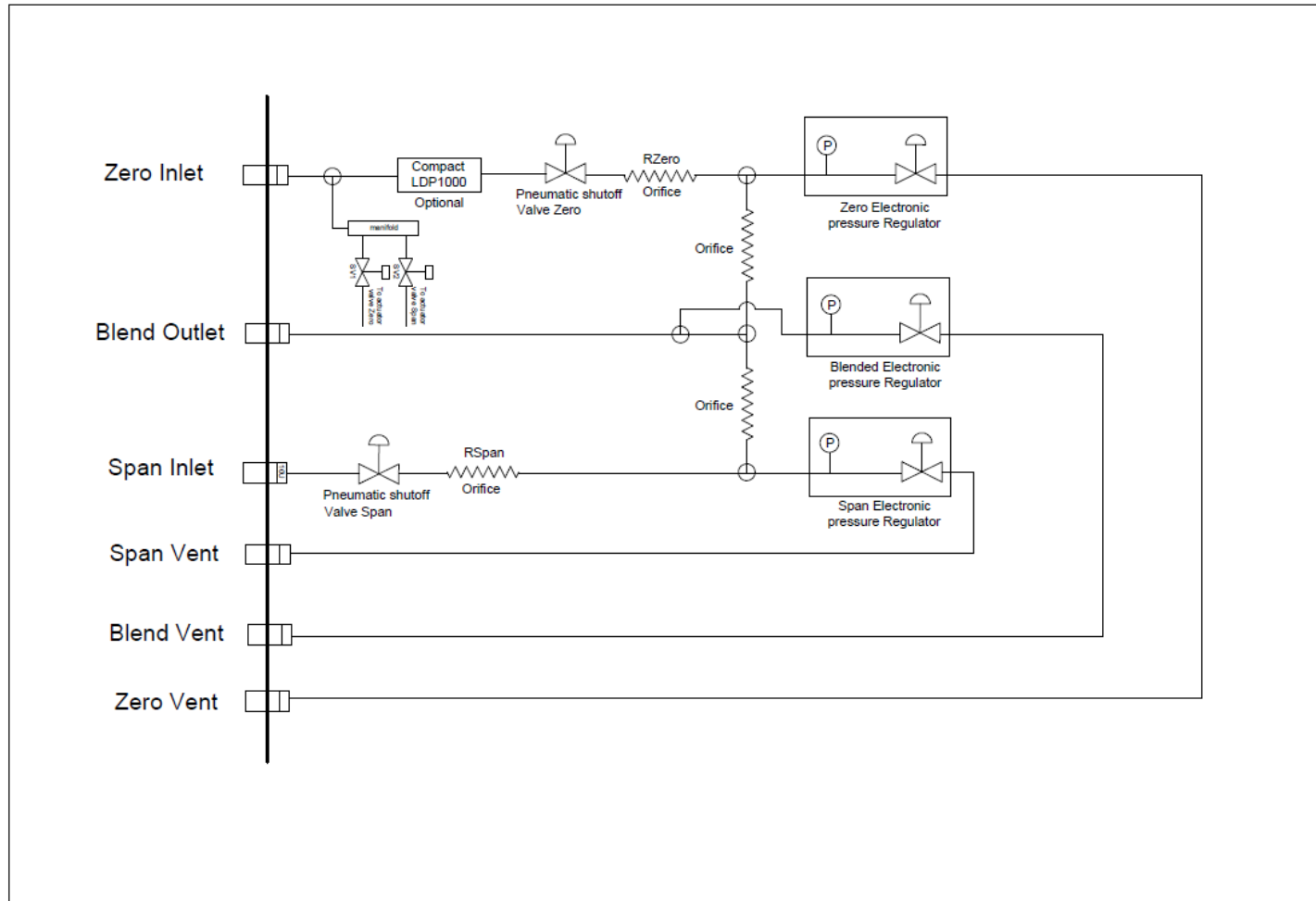

## 8.2. Dimensions & cutout

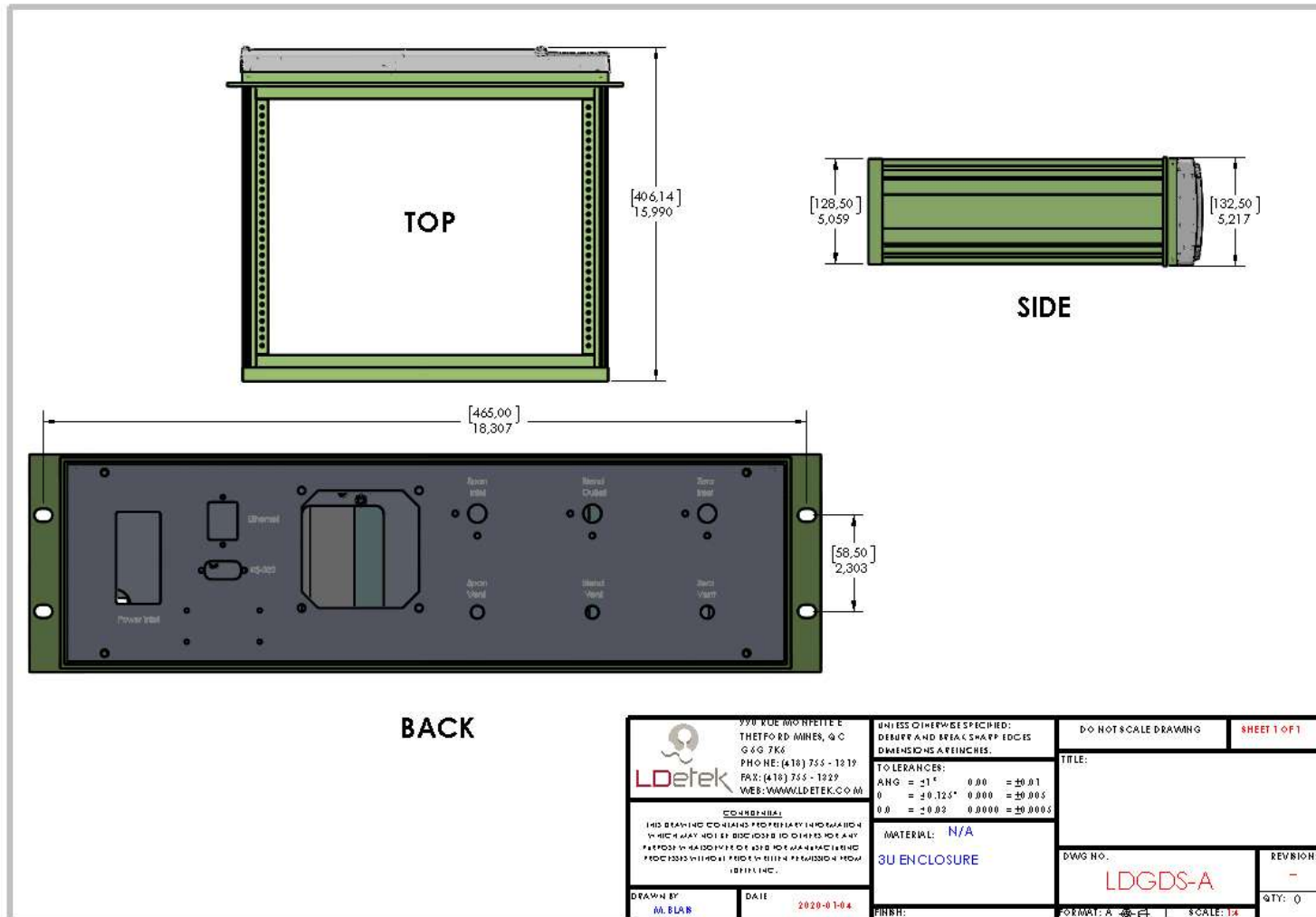

C:\SVN\SWConfig\Fonds de plan\A\_Part\_po.sldprt 6 mai 2020 06:44:32

### 8.3. Internal view

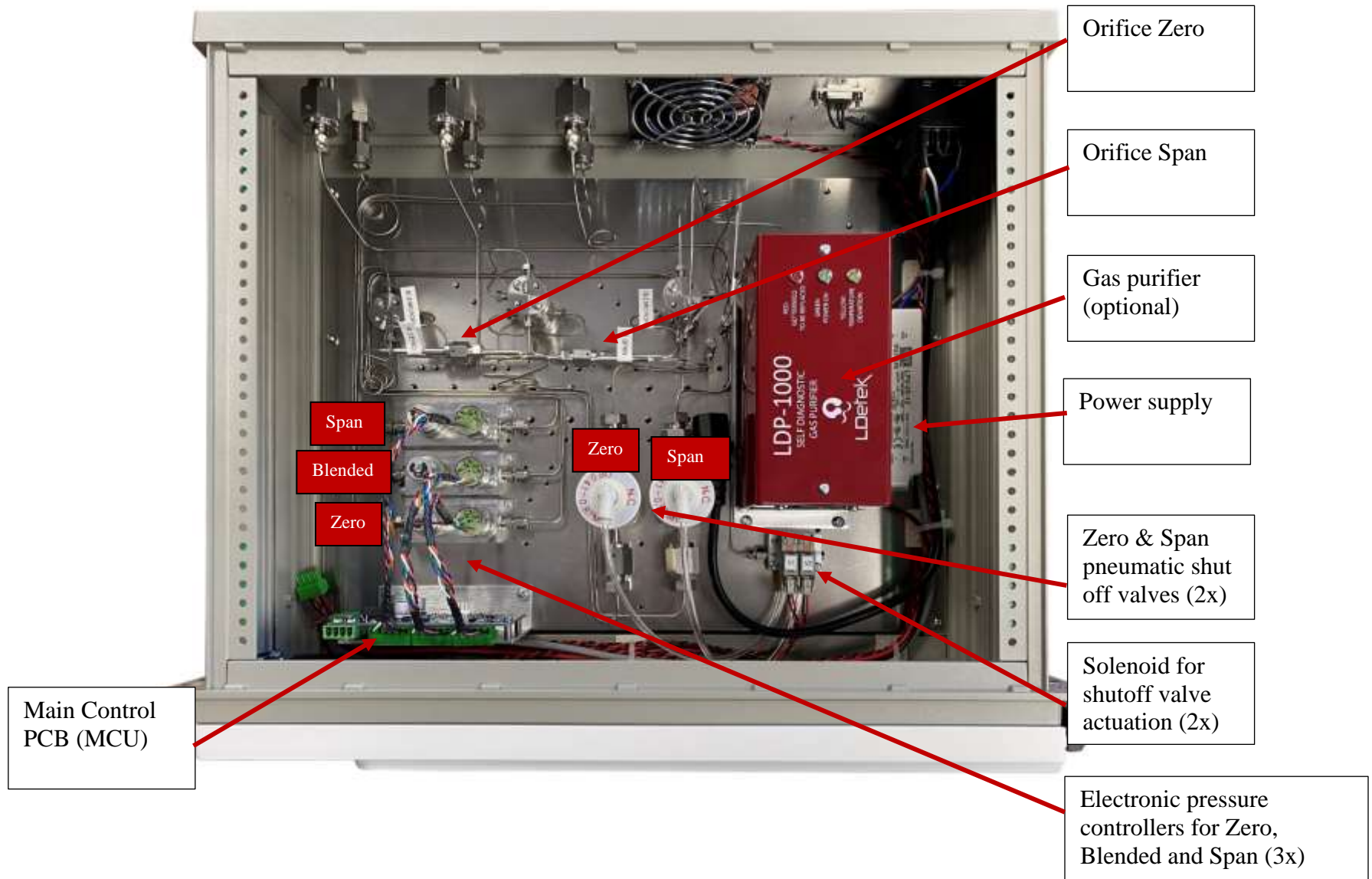

### 8.4. Back Panel view



### ***8.5. Front panel view***



### 8.6. Internal view with options 2 inlets for zero/span with dual purifiers

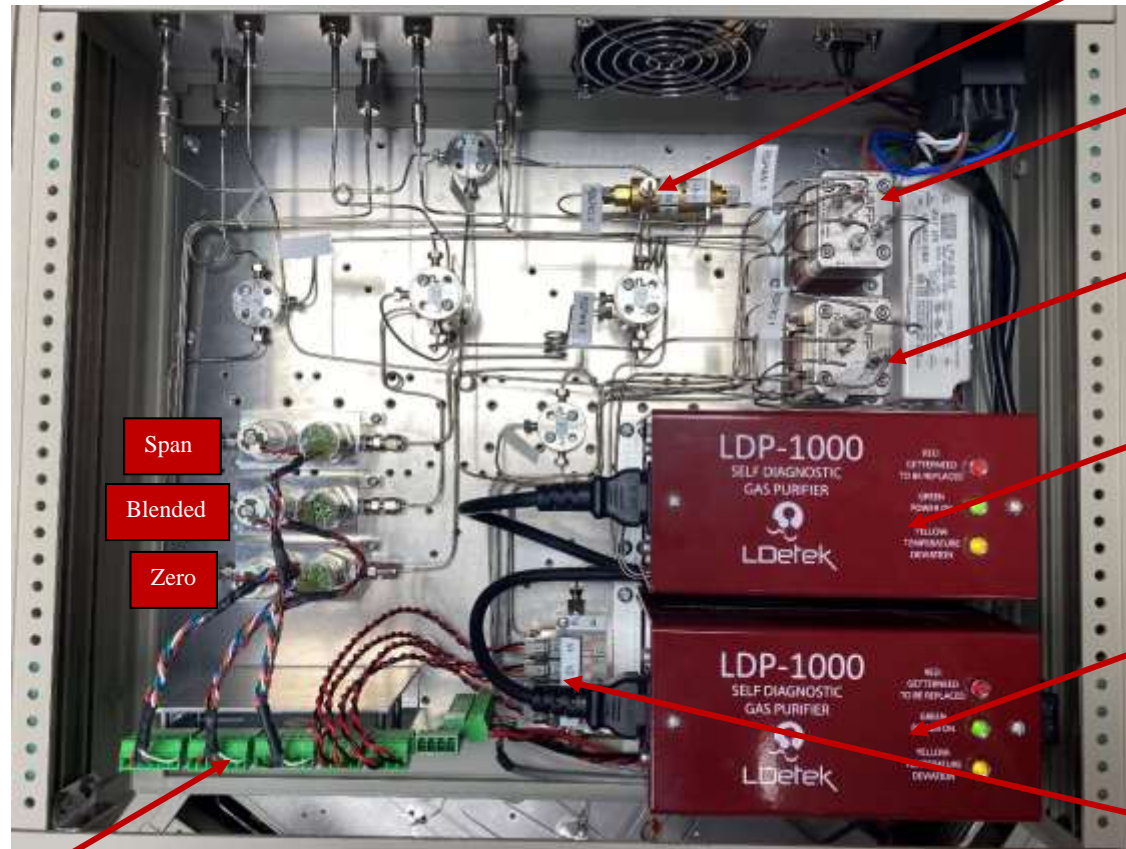

Pressure regulator adjusted at 65psig for valve actuation

2 streams diaphragm valve (Span) (optional)

2 streams diaphragm valve (Zero) (optional)

Gas purifier 2 (optional)

Gas purifier 1 (optional)

Solenoid 1 to 4 for valve actuation

Span  
Blended  
Zero

Main Control PCB (MCU)

### 8.7. Piping diagram with options 2 inlets for zero/span with dual purifiers

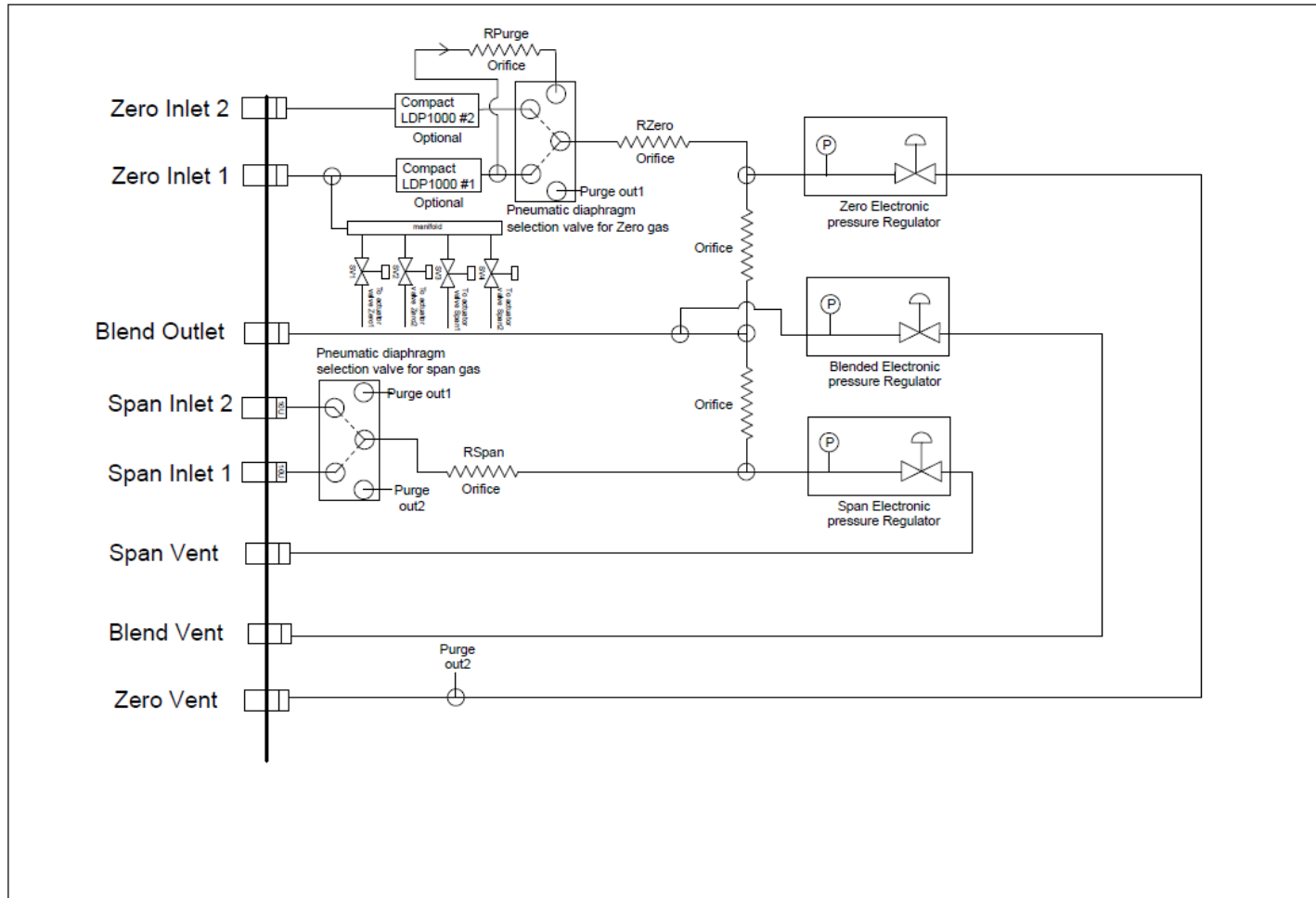

## 9. Ordering information

LDGDSA	-X	-X	-X	-XXXX	-XXX	-XX	-XX	-XX
	Zero Gas type: A: Argon H: Helium N2: Nitrogen (other possible on request)	Span Gas type: A: Argon H: Helium N2: Nitrogen (other possible on request)	ratio: 10 : 10 to 1 100: 100 to 1 1000: 1000 to 1 1 (other possible on request)	Inlet/Outlets Fittings 2SWG:1/8'' Swagelok  4SWG:1/4'' Swagelok  2VCR:1/8'' VCR  4VCR: 1/4'' VCR	Operating Voltage: 120 : 120 volts  220: 220 volts	C: Integrated heated gas purifier for zero reference  CC: Dual integrated heated gas purifier for zero reference	DS: Dual span inlets with 2 streams isolation valve	DZ: Dual zero inlets with 2 streams isolation valve





## 10. Maintenance

Referring to the spare part list: the manufacturer item numbers, the descriptions, the replacement frequencies as well as the associated procedure numbers are identified.

### 10.1 Spare part list

Contact LDetek service department with reference to the serial number of your instrument : [support@ldetek.com](mailto:support@ldetek.com) and they will send you the spare part list referring to your instrument

### 10.2 Frequently asked questions

Problems	Solutions (by priority)
Can't connect to the device	Instruction to fix the communication issue are explain in section 5.

Thanks for using LDetek Products





---

Where **innovation** leads to **success**

271 St-Alphonse Sud, Thetford Mines, (Qc), Canada, G6G 3V7  
Phone: 418 755-1319 • Fax: 418 755-1329 • [info@ldetek.com](mailto:info@ldetek.com) [www.ldetek.com](http://www.ldetek.com)

©Copyright 2013 LDetek Inc.

LDGDSA 1013-001