

GPR-Portable Oxygen Analyzers

User Manual PST-UM-3005-EN-00



Issue No.	Description	Date	Author Initials
00	New document	02/2024	IM, CK, KS, JW, OP



GPR-1100, GPR-1200, GPR-2000 Oxygen Analyzers

For contact information, visit
ProcessSensing.com

Analytical Industries Inc (Aii) is part of the Process Sensing Technologies Group (PST). This document is the property of Process Sensing Technologies and may not be copied or otherwise reproduced, communicated to third parties, nor stored in any Data Processing System without the express written authorization of Process Sensing Technologies.

©2024 Process Sensing Technologies

Before using your portable analyzer

Safety information

Please read this manual, ensuring that you fully understand the content before attempting to setup, maintain or use the portable analyzer. Important safety information is highlighted throughout this document as follows:



The electrical warning symbol indicates instructions that must be followed to avoid serious or fatal injury from hazardous voltages and electric shock.



The warning symbol indicates instructions that must be followed to avoid minor, serious or even fatal injury to personnel.



The **electrostatic discharge (ESD) warning** symbol indicates the user must take precautions and follow the necessary steps to avoid generating electrostatic discharge.



The **caution** symbol indicates instructions that must be followed to avoid damage to equipment (hardware and/or software) or the occurrence of a system failure.

NOTE: Highlights an essential operating procedure, condition, or statement.

Abbreviations

AC	Alternating Current
°C	Degrees celcius
°F	Degrees fahrenheit
DC	Direct Current
EC	Electrochemical
ELV	Extra Low Voltage
ESD	Electrostatic Discharge
FSD	Full-scale Deflection
barg	Gauge pressure (above ambient)
g	Grams
GND	Ground
H ₂ S	Hydrogen sulphide
IS	Intrinsically Safe
kg	Kilograms
LD	Liquid Drain
LDL	Lower Detection Limit
LED	Light Emitting Diode
LPM	Liters Per Minute
mA	Milliampere
OEM	Original Equipment Manufacturer
oz	Ounces
O ₂	Oxygen
ppb	Parts Per Billion
ppm	Parts Per Million
PC	Personal Computer
lb	Pounds
psig	pound-force per square gauge
PCB	Printed Circuit Board
PLC	Programmable Logic Controller
SCFH	Standard Cubic Feet per Hour
SS	Stainless Steel

Contents

Before using your portable analyzer	iii
Safety information	iii
Abbreviations	iv
1 Introduction	1
1.1 Overview	1
1.2 Models	2
1.3 Applications	2
1.4 Sensors	2
1.4.1 GPR-12-333	3
1.4.2 GPR-11-60-4	3
1.4.3 XLT-12-333	3
1.4.4 XLT-11-24-4	3
1.4.5 -H suffix	3
1.5 Further general considerations	4
1.5.1 Conditions of use in hazardous areas	4
1.6 Safety approvals and directives	5
2 Installation	6
2.1 Unpack your analyzer	7
2.2 Analyzer features	8
2.3 Set-up	9
3 Before connecting gas	10
3.1 Necessary considerations	10
3.2 Sample gas requirements	11
3.2.1 Inlet pressure	11
3.2.2 Outlet pressure	11
4 Connect your gas	12
4.1 Calibration gases	13
4.2 Prepare your zero/span gas	13
5 Disconnect your gas	14
6 Install your sensor	15
6.1 GPR-1100 and GPR-1200	15
6.2 GPR-2000	17
7 Operation	18
7.1 User interface	18
7.2 Initial start-up and self-test	19
7.3 Menus	20
7.3.1 Main Menu and interface keys	20
7.3.2 Range selection	21
7.3.3 Analyzer calibration	22
7.3.4 Data logging	26

- 7.3.5 System 28
- 7.3.6 Info 30
- 7.4 Recharge your battery 31

- 8 Maintenance 33**
 - 8.1 Replace your sensor 33
 - 8.2 Routine cleaning 34
 - 8.3 Routine inspection of sensor housing 35
 - 8.4 Troubleshooting 36

- 9 Warranty information 39**
 - 9.1 Coverage 39
 - 9.2 Limitations 39
 - 9.3 Exclusions 39
 - 9.4 Service 40

- 10 Appendices 41**
 - Appendix A - Technical Specifications 41
 - Appendix B - Hazardous Area Certification 42
 - Appendix C - Safety Data Sheet 43
 - Appendix D - Controlled drawings 51
 - Appendix E - Dimensions 52
 - Appendix F - Menu displays 54
 - Appendix G - Spare parts 55
 - Appendix H - Rating plate 56
 - Appendix I - Quality, recycling, and warranty information 57

1 Introduction

This user manual is applicable to the GPR-1100, GPR-1200 and GPR-2000 portable oxygen analyzers.

⚠ These products are for indoor and outdoor use. If they are used in a manner not specified by the manufacturer, the protection provided by this equipment may be impaired.

This document contains the following information for your analyzer:

- Installation
- Operation
- Maintenance and troubleshooting.

To ensure that the latest manual is being used please visit the PST website www.processsensing.com.

Access the latest datasheets, user manuals, certificates and more at the product page **Downloads** tab.



GPR-1200



GPR-1100
GPR-2000

1.1 Overview

GPR portable oxygen analyzers are reliable, compact, robust, and designed to perform verification measurements in a variety of industrial oxygen applications.

Features of our GPR portable range of analyzers include:

- Simple, intuitive HMI
- Additional sensors available
- User-selectable or automatic adjusted measurement ranges
- Gas temperature compensation
- Battery-powered configurations
- Range of sampling options available for different applications.

1.2 Models

The GPR range of oxygen analyzers covered in this manual are detailed as follows:

- GPR-1100 - ppm oxygen portable analyzer
- GPR-1200 - ppm oxygen portable analyzer
- GPR-2000 - % oxygen online analyzer.

These are battery-powered and certified for safe and hazardous area use indicated by the display. A blue display outline is for general use, red is for hazardous area as shown below.

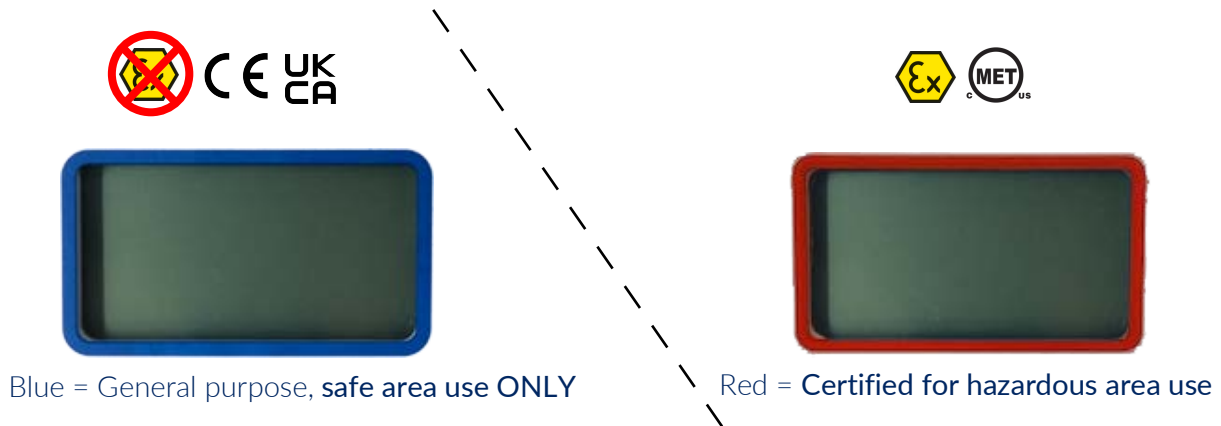

Figure 1. Safe area and hazardous area displays

1.3 Applications

- Monitoring inertization and blanketing gases for the storage or transport of hydrocarbons
- Monitoring natural gas quality
- Monitoring oxygen in pharmaceutical reactors and centrifuges
- Monitoring gas quality in processes: steel production, heat-treatment furnaces, solder re-flow ovens
- Monitoring pure gas quality on feed gases: the beverage industry, food packaging, N2 generators.

1.4 Sensors

Our maintenance-free electrochemical sensors are galvanic cells capable of superior performance, accuracy and stability; designed to be unaffected by the presence of background gases. As a consumptive sensor type, it is disposable and requires only periodic calibrations.

Operational life is typically up to 18 months however, replacement frequency is dependent on the individual application.

If contaminants are present in the sample gas, the sensor can be affected, and the validity of the measurement impacted. Please ensure that the sensor is protected, and any contamination is prevented from reaching the analyzer’s pipework and the sensor.

Consult the PST sales team about our cost-effective standard sample conditioning systems.

Table 1: Available sensor types

Analyzer Model	GPR-1100	GPR-1200	GPR-2000
Model Number	GPR-12-333 XLT-12-333 GPR-12-333-H	GPR-12-333 XLT-12-333 GPR-12-333-H	GPR-11-60-4 XLT-11-24-4
Recommended O ₂ Measurement Range	0...1000 ppm _v	0...1000 ppm _v	0...25 %
Minimum Range	0...10 ppm _v	0...10 ppm _v	0...1 %
Sensitivity	0.01 ppm _v	0.01 ppm _v	0.005 %

For full sensor technical specifications, please refer to "Appendix A - Technical Specifications" on page 41.

1.4.1 GPR-12-333

Our standard ppm sensor can be used to measure O₂ in a wide variety of gases.

Specific sensor selection should be given when the background gases are helium (He), hydrogen (H₂) or greater than 0.5 % carbon dioxide (CO₂).

1.4.2 GPR-11-60-4

The 0.25 % sensor can be used to measure O₂ in a wide variety of gases.

Specific sensor selection should be given when the background gases greater than 0.5 % CO₂.

1.4.3 XLT-12-333

For measurement applications with ppm levels of O₂ in a background gas containing more than 0.5 % CO₂, the specially designed XLT sensor should be selected.

With most standard electrochemical sensors, an alkaline electrolyte is used; this is neutralized over time when exposed to acid gases, such as CO₂. To combat this, PST has developed the XLT sensor with a special electrolyte formula, which maintains functionality in temperatures as low as -10 °C (14 °F).

1.4.4 XLT-11-24-4

Our 0...25 % sensor is for measurement applications with % levels of O₂ in a background gas containing more than 0.5 % CO₂.

With most standard electrochemical sensors, an alkaline electrolyte is used; this is neutralized over time when exposed to acid gases, such as CO₂. To combat this, PST has developed the XLT sensor with a special electrolyte formula, which maintains functionality in temperatures as low as -10 °C (14 °F).

1.4.5 -H suffix

For measurement applications with ppm levels of O₂ in a background gas of either H₂ or He, the specially design -H sensor should be selected for optimum performance.

NOTE: Calibration is required each time your sensor is replaced. Ideally, your sensor should be replaced before reaching the end of its operational life.

1.5 Further general considerations

When your portable analyzer is used with or in other equipment please consider the following:

- The analyzer should not be submerged in any liquid. Care should be taken to ensure liquids are not spilled and objects do not fall into the unit.
- Avoid force when using connectors, switches and knobs. Before moving your analyzer, be sure to disconnect the wiring/power cord and any cables connected to the output terminals.
- Ensure the sensor selected and supplied is suitable for the gas composition to which it will be presented; if in doubt, review the application and consult the PST Factory before initiating the installation.
- The products covered should be evaluated to the environmental conditions as defined by the standard up to 2,000 m (6,500 ft) altitude and within the temperature range applicable to your sensor; refer to "Appendix A - Technical Specifications" for details.
- The products covered by this manual should be installed using the manufacturer's instructions.
- Only the sensor provided by the manufacturer is to be used with the analyzer.
- In natural gas applications such as extraction and transmission, a low voltage current is applied to the pipeline itself to inhibit corrosion of the pipeline. As a result, electronic devices connected to the pipeline can be affected unless they are adequately grounded.

1.5.1 Conditions of use in hazardous areas

NOTE: Always ensure the power is switched off prior to accessing the Ex enclosure for any purpose other than normal operation, or prior to disconnecting any cables.

Only analyzers marked and certified for use in **hazardous areas** (identified with a **red** display outline) should be used in hazardous areas.

General purpose analyzers (with **blue** display outlines) are for safe area use only. See "1.2 Models" on page 2 for reference.



Using a general purpose analyzer in a hazardous area could lead to injury to personnel.

Refer to "Appendix B - Hazardous Area Certification" on page 42 for certification details.

1.6 Safety approvals and directives



The CE marking indicates the portable oxygen analyzer conforms to European health, safety, safety and environmental protection directives.



The Ex marking indicates the portable oxygen analyzer conformity to European Union directive 2014/34/EU (ATEX) and UK Statutory Instrument 2016 No. 1107 (as amended) (UKEX). It complies with Intrinsically Safe (I.S) standards for equipment category 2 when used following the instructions for safe use in this user manual. This makes it normally suitable for use in Zones 1 or 2 hazardous areas.



This UKCA marking demonstrates the portable oxygen analyzer complies with UK designated standards in electric and electronic engineering and measuring technology.



The MET marking certifies the portable oxygen analyzer is compliant in North America and Canada, with the electrical and hazardous location safety directive.

NOTE: The portable range of analyzers are not tri-rated. These analyzers are built to comply with ATEX / IECEx / UKEX or cMETus.

The hazardous area compliance rating is shown on the rating plate on the analyzer. Please ensure your analyzer is compliant with site or location requirements. This user manual details installation, operation and support for all our portable analyzers for all certifications.

2 Installation

NOTE: Installation, operation and maintenance of this equipment should be carried out only by appropriately trained and suitably qualified technicians in accordance with the instructions in this user manual, and any applicable standards/certificates associated with the country, industry and application.



Failure to correctly adhere to these instructions may result in injury to personnel. In this regard, the manufacturer will not be held liable.

NOTE: The operator may only perform modifications and repairs to the equipment or system with approval from the manufacturer.



Do not operate damaged equipment. If faults cannot be rectified, the equipment must be taken out of service and secured against unintentional commissioning.

Before using your portable analyzer, ensure that its specifications are suitable for the process in which it will be installed.

2.1 Unpack your analyzer

Your portable analyzer pack is comprised of the following equipment (pack contents may vary depending on your specification):

1. Portable analyzer
2. Sensor in double-foil packet (only applicable to ppm models without a crossover valve, the sensor is installed in all other portable analyzers)
3. Memory token
4. Memory token USB adapter
5. Battery charger
6. Output connector
7. PST Factory calibration certificate
8. Quick Start Guides (ref: PST-QSG-3203, span calibration, PST-QSG-3204, air calibration)
9. User Manual, this document (ref: PST-UM-3005) on a USB stick.



Figure 2. Contents of portable pack

2.2 Analyzer features

The portable analyzer is a single enclosure, hinged on the left side. The measurements for our portable analyzers are in "Table 2: Portable analyzer dimensions" below.



Figure 3. The portable oxygen analyzer

Table 2: Portable analyzer dimensions

Model	Dimensions (L x W x H)
GPR-1100	5.4 x 5.6 x 8.8 " (137.2 x 142.2 x 223.5 mm)
GPR-1200	10.5 x 6.4 x 10 " (266.7 x 162.6 x 254 mm)
GPR-2000	5.8 x 5.6 x 8.8 " (147.3 x 142.2 x 223.5 mm)

See "Appendix E - Dimensions" on page 52 for further information.

2.3 Set-up

The analyzer is approved for indoor as well as outdoor use if the ambient temperature remains within the specified range. Please refer to "Appendix A - Technical Specifications" on page 41.

This portable analyzer configuration is designed to be used on a flat horizontal surface.

The analyzer's design provides immunity from RFI/EMI by maintaining good conductive contact between the two halves of the enclosures via a conductive gasket (the smaller enclosure containing signal processing electronics).

The surfaces contacting the conductive gasket are unpainted. Do not paint these areas. Painting will negate the RFI/EMI protection.

3 Before connecting gas

3.1 Necessary considerations

With standard flow-through configuration, the portable analyzers are designed for positive pressure samples and require connections for incoming sample and outgoing vent lines.

Your analyzer is equipped with two gas ports as highlighted in [Figure 4](#). On the GPR-1200 model, the **Sample In** and **Sample Out** ports are labeled. With the GPR-1100 and GPR-2000 models, assign one of the ports the vent and the other Sample In.

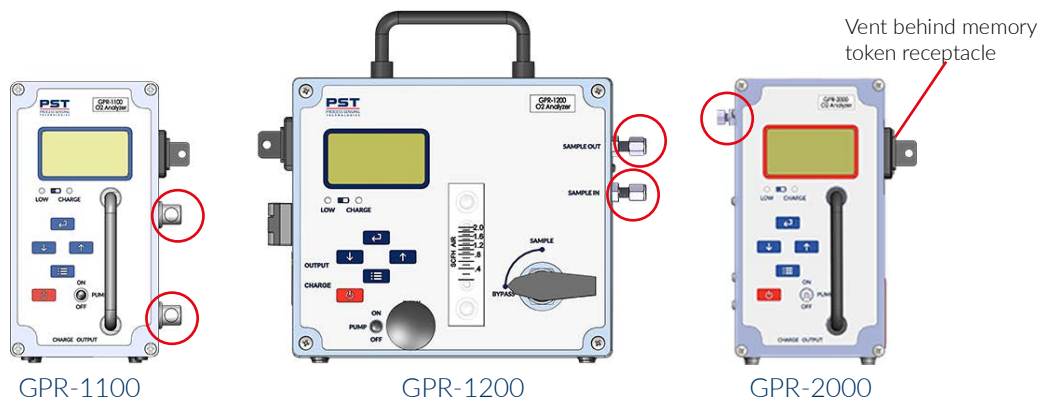

Figure 4. Gas ports

The sample inlet and outlet vent gas lines for the GPR-1100 model require 1/8" PTFE / PVDF tubing. The fittings are self-sealing push-fit fittings.

The sample inlet tubing for ppm portable analyzer models (GPR-1100 and GPR-1200) must be metallic, preferably stainless steel (SS). The sample vent line may be of SS or hard plastic tubing with low gas permeability.

PTFE sample inlet tubing is recommended for the GPR-2000 % portable analyzer.

To ensure the best possible operation, a review of the installation is recommended:

- a. Sample gas quality
 - Is the sensor suitable for gas?
 - Is a gas scrubber required?
 - Is the sample gas clean and liquid free?
- b. Stainless steel tubing (essential for maintaining the integrity of the gas stream for very low ppm or % level analysis.

NOTE: If operated in potentially contaminated gases, which can interfere with measurement and reduce the sensor’s life expectancy. Consult PST for recommendations concerning the proper selection and installation of components.

3.2 Sample gas requirements

All gas analyzers utilizing electrochemical oxygen sensors respond to partial pressure changes in oxygen. To ensure accurate measurement of the oxygen sample, gas must be presented to the analyzer at a stable pressure and flow rate.

3.2.1 Inlet pressure

For the analyzers designed to measure oxygen in a flowing gas stream, the inlet sample pressure must be regulated in the range 5...30 psig (0.34...2 barg).

3.2.2 Outlet pressure

It is recommended that the sample is be vented to atmospheric pressure or into a flare at atmospheric pressure. If this is not possible, it should be vented to a pressure that is less than the inlet pressure to allow the sample gas to flow through the sensor housing.

NOTE: The sensor may be used at a slightly positive pressure (e.g., when sample is vented to a common exhaust where the pressure might be higher than 1 atmosphere). However, the pressure at the sensor **must remain constant at all times including during the span calibration. This may be accomplished by using a back-pressure regulator on the vent line of the analyzer.**

If assistance is required to configure a measurement at a positive pressure, please contact PST with full application details for a review.



A sudden change in pressure at the sensor may result in the sensor electrolyte leakage.

4 Connect your gas

After reading "3 Before connecting gas" on page 10, follow the procedure below specific to your portable analyzer to connect your gas.



Do not place your finger over the vent (it pressurizes the sensor) to test the flow indicator when gas is flowing to the sensor. Removing your finger (the restriction) generates a vacuum on the sensor and may damage the sensor, voiding the sensor warranty.

See [Figure 4 on page 10](#) for port designation

GPR-1100

NOTE: The GPR-1100 analyzer is equipped with quick-disconnect fittings.

1. To ensure gas is venting to atmosphere, connect the vent line to a port.
2. Set the sample gas pressure between 5 and 30 psig (0.34...2 barg).
3. Set your flow rate to 1...2 SCFH (0.5...1 LPM) before connecting gas.
4. Connect your process gas line to the other port and allow gas to flow for 2...3 minutes to purge the system.
Your analyzer is now ready for operation.

GPR-1200

NOTE: The GPR-1200 analyzer is equipped with a bypass valve. Ensure it is in the Bypass position before connection gas.

1. With the bypass valve in the **Bypass** position, connect your gas line to the **Sample In** port.
2. Set the sample gas pressure between 5 and 30 psig (0.34...2 barg).
3. Set your flow rate to 1...2 SCFH (0.5...1 LPM) and allow gas to flow for 2...3 minutes to purge the bypass valve before connecting gas.
Your analyzer is now ready for operation.

GPR-2000

1. Set your flow rate to 1...2 SCFH (0.5...1 LPM).
2. Connect your process gas line to the port using the fitting provided.
3. Start the flow of gas and allow it to flow for 2...3 minutes.
Your analyzer is now ready for operation.

Span calibration gas ports are offered as part of the optional sample systems.

NOTE: If the analyzer is equipped with an optional H₂S scrubber, sample inlet pressure must not exceed 30 psig (2 barg).

4.1 Calibration gases

NOTE: It is recommended that you use certified zero and span gases for calibration to ensure the best measurement readings.

Cylinders of the appropriate certified zero and span gases should be made available for verification of the analyzer's performance. Calibration gases will need to be set to the same input pressure and flow rate as the sample gas to ensure calibration integrity.

4.2 Prepare your zero/span gas

Avoid contamination of the zero/span gas cylinder when connecting the pressure regulator. Bleed the air-filled regulator for a couple of minutes before closing the vent valve of the pressure regulator (faster and more reliable method of purging the regulator than simply allowing the zero/span gas to flow through the regulator and the span gas line).

The following components/tools are required to set up a zero/span gas cylinder:

- a. Certified zero/span gas cylinder with an oxygen concentration, balance nitrogen, of approximately 80 % of the full scale range above the intended measuring range.
- b. A pressure regulator to enable reduction of gas pressure to between 5 and 30 psig (0.34 and 2 barg).
- c. A flow meter (for use only if the analyzer is not equipped with one) to set the flow rate between 1 and 2 SCFH (0.5...1 LPM).
- d. Suitable fittings and 1/8" diameter metal tubing to connect the regulator to the inlet of the analyzer.

Ensure your zero/span gas cylinder valve is closed, then:

1. Install the regulator on the cylinder using good practice.
2. Open the regulator's exit valve and partially open the pressure regulator's control knob.
3. Slightly open the cylinder valve.
4. Loosen the nut connecting the regulator to the cylinder and bleed the pressure regulator.
5. Re-tighten the nut connecting the regulator to the cylinder.
6. Adjust the regulator exit valve and slowly bleed the pressure regulator.
7. Open the cylinder valve completely.
8. Set the output pressure between 5 and 30 psig (0.34 and 2 barg) using the pressure regulator's control knob.



Do not exceed the recommended pressure. Excessive pressure will make flow adjustment more difficult.

5 Disconnect your gas

Follow the procedure below that is applicable to your portable oxygen analyzer model to disconnect your gas.

GPR-1100

1. Disconnect your span gas line using the quick disconnect fitting.
2. Stop the flow of gas.
3. Now disconnect the gas line venting to atmosphere using the quick disconnect fitting.

GPR-1200

1. Turn the Bypass Valve to the **Bypass** position then stop the flow of gas.
2. Disconnect your span gas lines from the Sample In and Sample Out ports.

GPR-2000

1. Stop the flow of gas.
2. Disconnect the sample gas line by loosening the fitting.

6 Install your sensor

NOTE: Please read through this procedure and "3 Before connecting gas" on page 10 before attempting to install your sensor.

Your portable oxygen analyzer is equipped with stainless steel sensor housing. This housing offers ease of replacement of sensor whilst preventing any leakage into the system. The two sections of the sensor are held together by a metal clamp secured in place by an easy to access bolt.

The integrity of the sensor housing has been tested at the PST Factory prior to shipment.

The analyzer must be calibrated once the installation has been completed and periodically thereafter.

6.1 GPR-1100 and GPR-1200

To install or replace an oxygen sensor:

1. Press  to switch on your portable analyzer.
2. Using a screwdriver, remove the four screws to open the front of the enclosure.
3. Open the sensor housing (refer to [Figure 5](#) below for guidance).

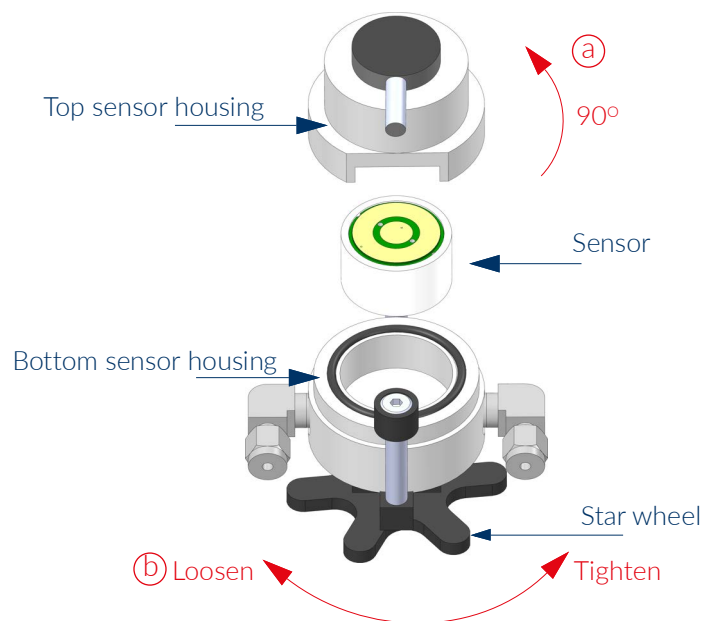

Figure 5. Installing and uninstalling your sensor (GPR-1100 and GPR-1200)

4. Loosen the star wheel then disengage the top sensor housing by turning it 90° counter-clockwise.
5. If replacing your sensor, remove the old sensor from the sensor housing, otherwise continue to the next step.

6. Remove the sensor from its packaging, remove the shorting flags and immediately place in the top sensor housing with the gold contact plate facing towards two gold contact pins in the top sensor housing as shown in [Figure 6](#).



Figure 6. Aligning your sensor

NOTE: You may perform a zero and span calibration or an air calibration to confirm that the sensor output is within the recommended limits. See "Zero and span vs span calibration" on page 23 for guidance.

7. Secure it with the star wheel at the bottom of the housing assembly (refer to 'b' in Figure 5 on page 15).
8. Quickly close your analyzer and connect your process sample gas or zero oxygen gas immediately, following the procedure in "4 Connect your gas" on page 12.

6.2 GPR-2000

To install or replace an oxygen sensor:

1. Press  to switch on your portable analyzer.
2. Using a screwdriver, remove the four screws to open the front of the enclosure.
3. If replacing the sensor, disconnect the sensor cable from the old sensor by turning the lock nut counter-clockwise, otherwise continue to step 5. Refer to [Figure 7](#) below.

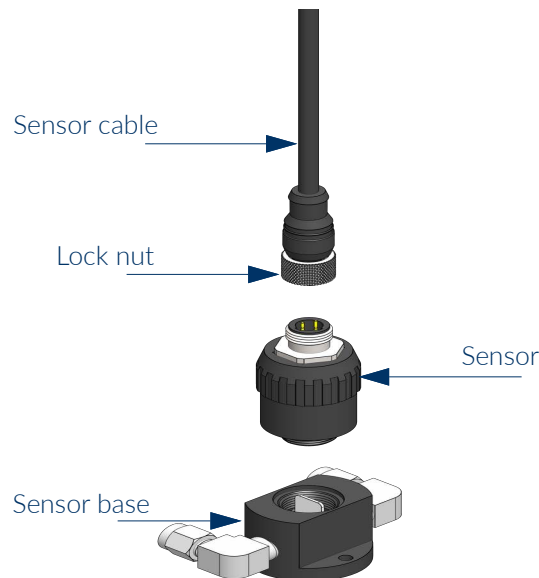

Figure 7. Installing and uninstalling your sensor (GPR-2000)

4. Remove the sensor from its base by unscrewing counter-clockwise.
5. Remove the new sensor from its packaging and screw it into the sensor base.
6. Reconnect the sensor cable by plugging it into the sensor and turning the lock nut clockwise.
7. Replace the enclosure door, securing it with the four screws.

7 Operation

This section details the best practice operation for a correctly installed analyzer. Please refer to "2 Installation" on page 6 for analyzer installation guidance and gas connection.

7.1 User interface

The portable analyzer has a 3.5-inch LCD display and a five-key keypad interface.

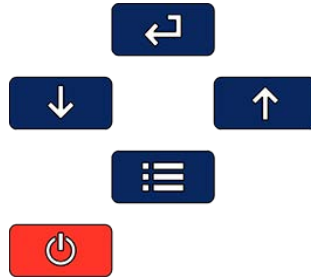







Figure 8. Portable analyzer user interface

The interface keys can be used as identified in the table below:

Table 3: Interface key functions

Key	Function
	On/off
	Menu open/close
	Enter
	Next (increment)
	Previous (decrement)

Only analyzers marked and certified for use in **hazardous areas** (identified with a **red** display outline) should be used in hazardous areas.

General purpose analyzers (with a **blue** display outline) are for safe area use only. See "1.2 Models" on page 2 for reference.

 **Using a general purpose analyzer in a hazardous area could lead to injury to personnel.**

7.2 Initial start-up and self-test

Once you press the  button, the analyzer will immediately start up. The digital display responds instantaneously and will display an initial start-up screen:



Figure 9. GPR-series analyzer start-up screen

After self-diagnostic tests, the analyzer switches to sampling mode and displays the oxygen reading from the sensor (larger size numeric value) and the measurement range (small size font with units).

Auto indicates that the analyzer is in AUTO mode. In this mode, the measured value affects the range, which will automatically adjust to the next higher level. See **Range** (page 21) in the **Main Menu** to select.

If the **Auto** is not selected, the range display will not show **Auto**. An example of a sampling mode screen is shown below in [Figure 10](#).



Figure 10. Measurement mode display

7.3 Menus

NOTE: Available menu options and sequences will vary between analyzer model and sensor type.

7.3.1 Main Menu and interface keys

To access the Main Menu, press the **Menu** key and the following Main Menu display will appear:

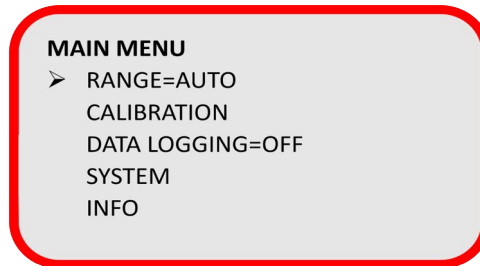





Figure 11. Main menu display

This screen shows the menu options available.

- Use the  and  keys to move the cursor to the desired menu
- Press  to access the sub menu
- Use the  key to return to the previous screen.

Range

Configure analyzer measurement range (see "7.3.2 Range selection" on page 21).

Calibration

Perform zero or span calibration functions (see "Zero and span vs span calibration" on page 23).

Data logging

Configure on board logging function (see "7.3.4 Data logging" on page 26).

System

Configure system-level settings (see "7.3.5 System" on page 28).

Info

View analyzer information (see "7.3.6 Info" on page 30).

7.3.2 Range selection

Within the Range menu, you can select 6 options. The range is linked to the display and the 4...20 mA analog output of the analyzer.

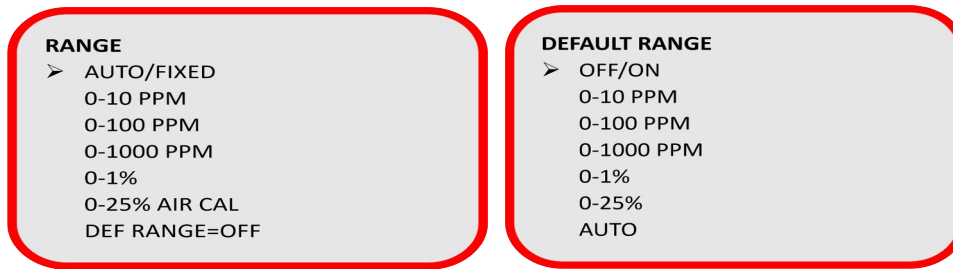







Figure 12. Portable analyzer Range and Default Range displays

NOTE: For trace oxygen analyzers, the range 0...25 % is for air calibration purposes only. It is not a measurement range of the analyzer (see " Zero and span vs span calibration" on page 23 for calibration). Using this range will significantly shorten the sensor life.

Range menu options

In the Range menu:

1. Use  and  to move the cursor to the desired range option.
2. Once the cursor is pointing to your chosen range, press  to select the range.

Selecting a range will cause the **Auto** option to change to **Fixed**. To select Auto, use  to move the cursor to **Fixed**, then press  to toggle between **Auto** and **Fixed**.

Auto

Selecting **Auto** will enable automatic adjustment of your measurement range depending on the oxygen levels detected by your oxygen sensor. For example, a 0...10 ppm range will change to 0...100 ppm if the measured oxygen value is higher than 10 ppm.

Default Range

This option will prevent incorrect range-setting if multiple users have access to the analyzer.

If the analyzer range has been changed, for instance for the purpose of checks or maintenance, and a default range has been pre-set, the analyzer will automatically return to the default range after 30 minutes of inactivity.

Def Range allows you to set the default range for the analyzer. Within this sub-menu, all standard ranges or **Auto** mode can be selected.

It is recommended that you set your preferred default range for the analyzer.

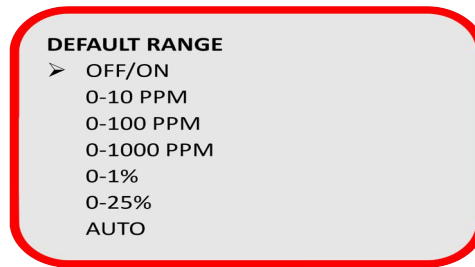

Figure 13. Default Range display

Measurements outside manual range

If the oxygen reading goes above the manual or auto range maximum value, the values will be displayed up to 10% above the maximum range. Beyond this, an OVER RANGE warning will be displayed.

7.3.3 Analyzer calibration

All electrochemical sensor-based analyzers require periodic calibration. The electrochemical sensor signal will remain relatively constant throughout its useful life, however, some components in a gas stream, e.g. sulfides, can adversely affect the sensor causing changes in sensitivity with time. As such, regular calibration is recommended to ensure accuracy and ascertain the integrity of the sensor (e.g. weekly intervals to a 3-month maximum).

It is the user’s responsibility to determine the frequency of calibration or verification. This should take into account the significance of the measurements that are being performed.

Always use good calibration practices.

- Calibrate the analyzer at or close to the temperature and pressure of the sample gas
- Use known reference gases or fresh air
- Allow suitable stability time especially when making significant changes in measurement value (e.g. 20.9 % to 0.0 %). See the table below.

Table 4: Example stability times

Condition example	Typical stability time
<1 % to air (20.9 %)	<3 minutes
Air (20.9 %) to 0.1%	<30 seconds
Air (20.9 %) to 0.01%	<2 minutes
2 minute air exposure to 10 ppm	60 minutes

Set sensor serial number

Updating the sensor serial number is critical for the calibration process.

When replacing O₂ sensors it is important to update the sensor serial number. To view the current 9-digit sensor serial number, enter the **Calibration** menu.

The sensor serial number can be seen in the menu as shown below:



Figure 14. Calibration display

NOTE: Entering a new serial number will reset calibration (span and zero) to default values and erase the Calibration Log.

To change the sensor serial number:

1. Use  to select **Sensor SN=00000000**.
The display will change as shown below in [Figure 15](#).

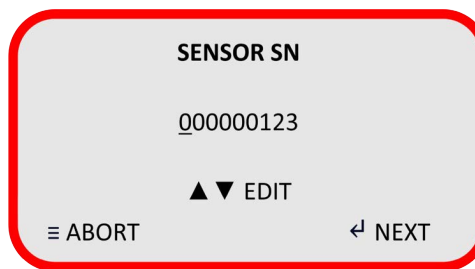







Figure 15. Sensor serial number display

2. Enter your sensor serial number by using  or  to edit the value.
3. Press  to progress to the next digit or  to move to the previous digit.
4. When you have entered your sensor serial number's last digit, press  to **Accept** the new serial number.

Zero and span vs span calibration

Electrochemical oxygen sensors generate an electrical current that is linear or proportional to the oxygen concentration in a sample gas. In the absence of oxygen the sensor exhibits an absolute zero, i.e. the sensor does not generate a current output in the absence of oxygen. Given the properties of linearity and an absolute zero, a single point calibration is possible.

Zero calibration is required for any measurement below the analyzer's lowest measurement range.

Span calibration is required routinely for accurate measurements of oxygen.

NOTE: Zero calibration should always be carried out before a span calibration.

Span calibration

To perform a Span Calibration, enter the **Calibration** menu and select **Span Calibration**.

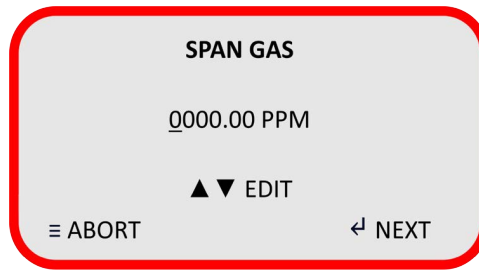

Figure 16. Span gas display

In the sub-menu, set the Span Gas value. If using certified cylinder gas, this can be found on the certificate that was supplied with the cylinder:

1. Use to progress to the next digit or to move to the previous digit; use and to edit the values.
2. Now select the calibration gas units (% or ppm).
3. When you press , the analyzer will switch to the appropriate range and display the live readings.

NOTE: When a Span or Zero Cal starts, only "Abort" when is shown until the reading is stable, then "Accept" when appears.

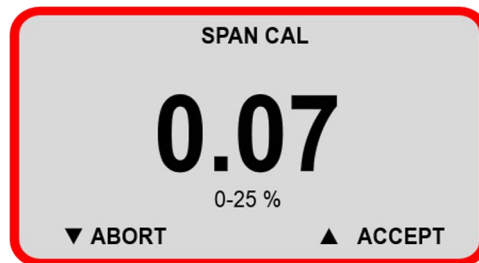

Figure 17. Span calibration display

During calibration ensure stability of readings, secure gas connections and supply of suitable reference gas.

Once gas readings are stable you can **Accept** or **Abort** the calibration. The calibration will **Pass** or **Fail** and the analyzer will return to normal operation at the configured range.

If a first span calibration receives a **Pass** this indicates the measurement was within acceptable limits. Subsequent span calibrations will pass when output is between 70 % and 115 % of the first span calibration.

A first span calibration will **Fail** if the sensor is weak. This is indicated with a measurement outside of the acceptable range. An alert in the form of a persistently blinking error message on the analyzer's **Home** screen will indicate a weak sensor.

Subsequent span calibrations will fail if the output is lower than 80 % of the first span calibration, if it drops by 30 % of the first span calibration, or if it increases above the first span calibration by 15 %. This could be caused by a bad first calibration or a bad sensor.

If your span calibration fails, use the **Reset Calibration** function.

NOTE: If using a ppm sensor we do not recommend exposure of the sensor to ambient air as it will significantly degrade the sensor life.

Zero calibration

The zero calibration adjustments are limited to 30 % of the most sensitive range. All analyzers are QC-tested to confirm the zero calibration. Should you observe a zero calibration error more than 30 % of the lowest range, we recommend first:

- Check the sample system for any possible leaks
- Confirm the integrity of the zero gas
- Ensure the analyzer has been given enough time to stabilize on the zero gas
- Ensure CLIP = OFF. Refer to "Clipping" on page 29 for information.

If adequate time is not allowed for the analyzer to establish the true baseline and a ZERO calibration is performed, the analyzer will likely display a negative reading in the sample mode when exposed to zero gas. If a negative reading is observed, we recommend repeating the ZERO calibration.

To perform a zero calibration:

1. Enter the **Calibration** menu and select **Zero Calibrate**.
The analyzer will switch to **Zero Cal** mode and display the live readings.

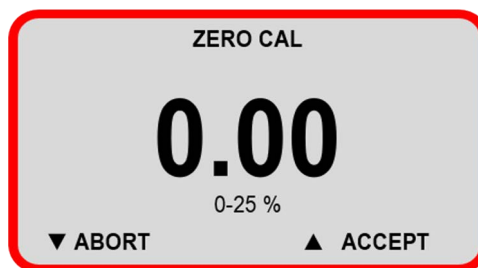

Figure 18. Zero calibration display

2. Once gas readings are stable you can **Accept** or **Abort** the calibration.
The calibration will **Pass** or **Fail** and the analyzer will return to normal operation at the configured range.

During calibration ensure stability of readings, secure gas connections and supply of suitable reference gas.

Calibration log

The Cal Log shows a summary of events on the analyzer. A total 256 records can be recorded.

Details included are shown below;

Date	Cal Type	Correction Value	Pass/Fail
01/01/23	RST		
01/01/23	SPN	-0.05	P
01/01/23	ZRO	-1.00	F

ZRO =	Zero calibration
SPN =	Span calibration
RST =	Reset calibration to factory calibration

NOTE: The correction value does not relate to actual readings it is a proportional value. This value can be used by the PST Factory for diagnostics.

Reset calibration

This function will reset both span and zero calibration information to default values. It will not clear the Calibration Log.

7.3.4 Data logging

The analyzer has an on board logging function. The logging rate is 60 seconds and capacity is 30 days.

Logging is enabled via the **Data Logging** menu:

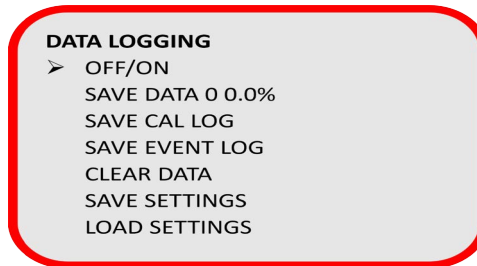

Figure 19. Data logging display

See "Table 5: Data logging functions" on page 27 for the functions of each menu item.

Table 5: Data logging functions

Function	Action
Off/On	Switch the data logger on or off
Save Data 0 0.0%	The first figure represents the number of data files stored The percentage figure represents the amount of memory used (100 % = 30 days)
Save Cal Log	Save the current calibration log (to the memory token)
Save Event Log	Save the current event log (to the memory token)
Clear Data	Clears all previously logged data (from the internal logger)
Save Settings	Logs or backs up current settings (to the memory token)
Load Settings	Loads configuration settings from the memory token to the analyzer

To enable logging:

1. Switch the first menu item from **Off** > **On**.
2. When the analyzer's 30-day memory is full, logging will automatically stop and an alert will be shown on the main screen.



The memory token must be inserted in the analyzer in a Safe Area only.

To export data:

1. Insert the memory token into the analyzer.
2. Use the interface buttons to select:
 - **Save Data** to export log files
 - **Save Cal Log** to export the calibration log data
 - **Save Event Log** to export the analyzer event log.



Figure 20. Data logging memory token

Once exported to the memory token, the data can be transferred to a Windows PC via its USB port. Data stored on the memory token is in .CSV format.

On board data can be cleared using the **Clear Data** menu item.

Export or import device settings

The Data Logging menu can be used to export your analyzer settings for loading to other analyzers.

To export analyzer settings:

1. Insert the memory token into your analyzer.
2. Select **Save Settings** using the interface navigation keys.

To import analyzer settings:

1. Insert the memory token with the saved settings file into the analyzer to which you want to load the settings.
2. Select **Load Settings** using the interface navigation keys.

7.3.5 System

Use the System menu to make the system adjustments shown in [Figure 21](#).

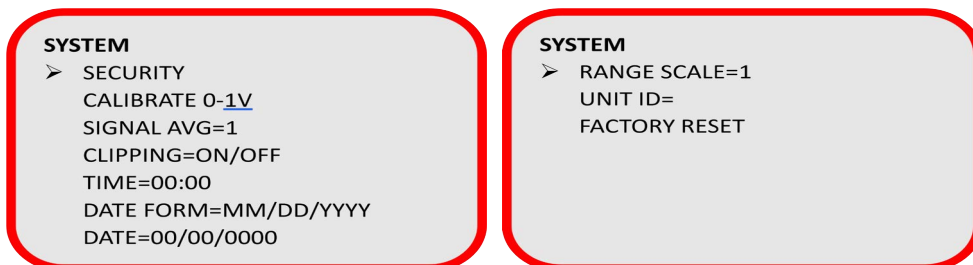

Figure 21. System display



Figure 22. System sub-menu displays

Security

- Enable Screen Lock with a pass code (default code is 0000)
- Set Pass Code > Set the 4-digit pass code
- Enable Auto Lock > Locks the screen after 30 minutes.

Calibrate 0-1 V

This sub-menu ensures alignment between the analyzer and your data acquisition system so that readings are consistent. Two calibration points - zero and full scale - will offset and scale the output.

1. Use the keypad to adjust the reference corrections for both 4 and 20 mA outputs.
2. Select **Accept** to apply the adjustments or **Abort**.

Signal AV - signal average

This function enables the setup of a measurement rolling average. A value between 1...100 readings can be used in a simple average calculation for the display measurements. Measurements are made at 1 Hz so that a value of 60 will give a 1-minute rolling average.

Higher signal average will help remove measurement instability but will reduce measurement response.

Clipping

Enabling Clipping will stop the analyzer displaying negative readings below 0 ppm_v / 0 %. A negative reading may occur when:

- Electronics drift or malfunction
- The sensor drifts
- The system's leak rate changes
- The sensor is bad
- A premature zero calibration is performed (most common)
- There's pressure change at the sensor.

Time

Sets the on board 24-hour clock for data logging.

Date form

This user-configurable functions enables you to set your date format preference to one of the following:

mm/dd/yy
dd/mm/yy
yy/mm/dd

Date

Set the on board device date (after a full power cycle the date time will be 00:00 1 Jan 2000).

Range scale

Adjusts the ppm range max value by a multiple (1-5). For example, setting Range Scale to 5 will give the following Range Options in the **Range** menu:

- 0-50 ppm
- 0-500 ppm
- 0-5000 ppm

Your analyzer is supplied with a Range scale of 1 as standard. This will generate ranges of:

- 0-10 ppm
- 0-100 ppm
- 0-1000

NOTE: Range scale only applies to the lowest three ranges of group 1 O₂ (10, 100, 1000 ppm O₂).

Unit ID

Allows an Alpha numeric ID to be given to the analyzer. This value will be stamped on log files and viewable in the INFO sub-menu.

Factory reset

Reverts all settings to Factory Configuration including security settings, sensor calibration and analog calibration.

7.3.6 Info

The **Info** menu displays the device information including:

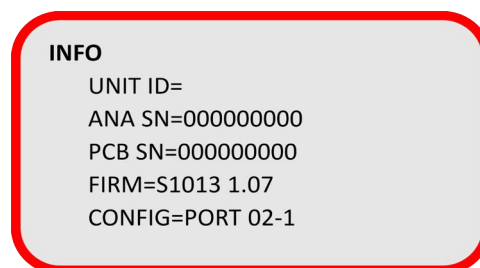

Figure 23. Info display

- **UNIT ID:** User defined (this is left blank for user, usually a location ID or asset number is entered here)
- **ANA SN:** Serial number of the analyzer (The 9-digit analyzer serial number is also displayed in log files)
- **PCB SN:** Serial number of the circuit board (a 9-digit number)
- **FIRM:** Firmware part number and revision
- **CONFIG:** This number refers to your analyzer's power, gas and Factory group number.

7.4 Recharge your battery

The analyzer is powered by an integrated lead-acid rechargeable battery that is mounted inside the housing.

A 9 V DC/AC battery charger is supplied with your analyzer. It can enable indefinite operation whilst the analyzer is plugged in, and continuous operation during the 12-hour charging cycle.

 **All analyzers, whether General Purpose or Hazardous Area, must be charged in a Safe Area only.**

The analyzer's charging circuit accepts only 9 V DC from any standard AC 110 V or 220 V adapter (with positive supply in the center of the female charging jack).

When your analyzer's battery requires a recharge, a **Low** LED will light up, indicating there are 72 hours of battery life remaining.

NOTE: The battery must be recharged within the 72-hour window to prevent permanent damage.

To charge your battery:

1. Unless the analyzer is being used while charging, press  to turn it off.
2. Plug the 9 V DC adapter supplied with your analyzer to a 110 V or 220 V outlet.
3. Connect the jack to your analyzer's charging port, which is located at the bottom as shown in [Figure 24](#)
The **Charge** LED at the front of the analyzer will be illuminated during the charging cycle.

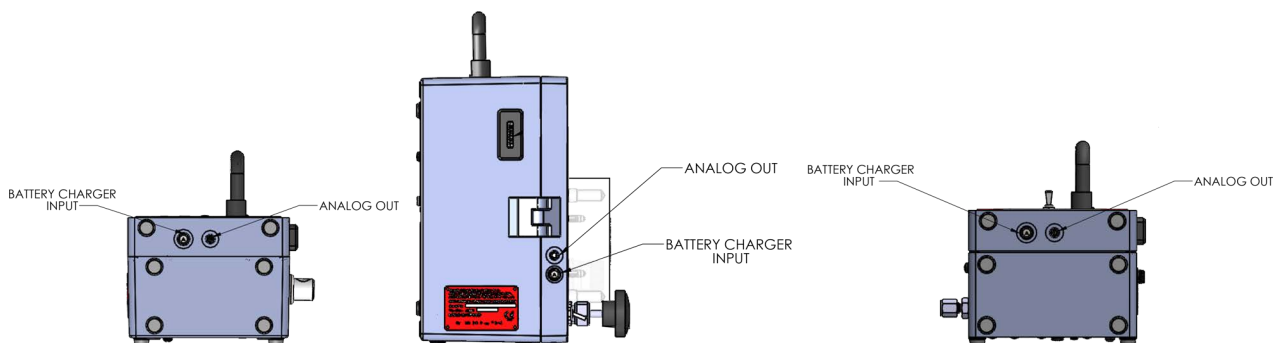

Figure 24. Battery charging input

A single charge will enable you to use your portable analyzer unplugged for 30 days. If your analyzer is fitted with integrated sampling pumps, the battery life will be 24 hours if used continuously.

8 Maintenance

The portable analyzer will provide reliable and fault-free service with regular maintenance and calibration.

During periods without use, the sensor should be purged with nitrogen or argon gas to preserve the sensor life.

- GPR-1100: This model has self-sealing connectors to trap purge gas preserving the sensor
- GPR-1200: This analyzer requires valve operation, to protect the sensor from depletion the valve must be in the "Bypass" position
- GPR-2000: The % sensor in this analyzer will not deplete with exposure to open air.



Do not attempt to make repairs to the analyzer. This will void the warranty and may result in electrical shock, injury, or damage. All servicing should be referred to qualified service personnel.

Some parts of your portable analyzer may require replacement due to normal wear. For a full list of replaceable parts and item codes, please refer to "Appendix G - Spare parts" on page 55.

8.1 Replace your sensor

To maintain performance, the sensor in your portable analyzer will require replacement. Sensor life is application dependent.

When your sensor reaches the end of its serviceable life, calibration can no longer be performed and the sensor must be replaced.

Depending on the application, our EC sensors can last between 12 and 24 months. Sensor life is a combination of shelf and operational life. Shelf-life is typically 3...6 months when stored in an inert environment. Factors that affect sensor life include:

- Sample gas contaminations i.e. acid gases and/or moisture
- The oxygen concentration level being measured - the higher the concentration the shorter the sensor life
- Sample gas temperature - a sample gas that is very dry or has an elevated temperature can lead to the electrolyte drying out and a shorter sensor life.

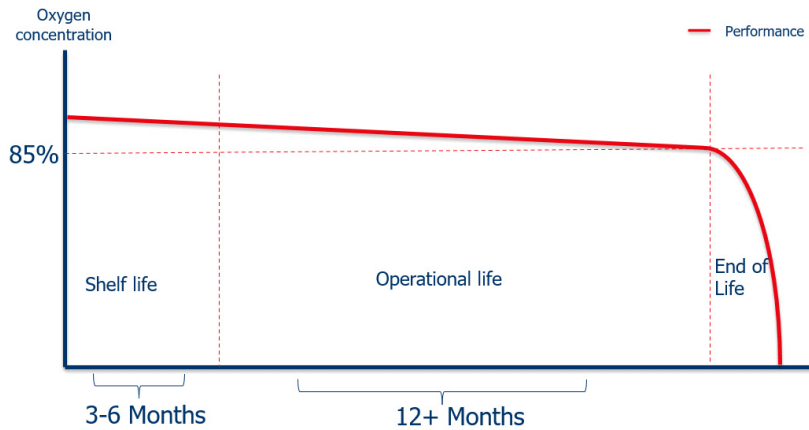

Figure 25. Sensor performance chart

A regular program of calibration will mitigate against sudden sensor failure. It is advisable to establish a program of preventative maintenance to ensure process downtime is kept to a minimum or avoided.

The protective plugs on your sensor should only be removed when your portable analyzer is installed and ready to begin gas measurement.

Refer to "3 Before connecting gas" on page 10 for the sensor installation procedure.

8.2 Routine cleaning

During sensor replacement, it is recommended that light cleaning of electrical contacts is carried out.

⚠ Never use chemical cleaning agents, solvents or high pressure water or steam to clean the equipment. Do not submerge in water.

To perform routine cleaning:

1. Use a clean cloth that is damp with water to wipe away dust and dirt from the outside of the unit.
2. Dry the analyzer with a clean, dry cloth.

8.3 Routine inspection of sensor housing

The maximum interval between routine inspections should be determined with consideration of the application and importance of the measurement.

The interval should be reassessed on a regular basis and can be extended and reduced as the process control requires.

This can be carried out during sensor replacement. To perform routine inspection:

1. Ensure the gas entry and vent ports on the sensor housing are not obstructed.
2. Inspect the sensor housing seal and replace it if damage is visible.

To replace the sensor housing seal:

1. Using a screwdriver, loosen the enclosure screws to remove the front cover.
2. Loosen the star wheel underneath the sensor assembly by turning it counter-clockwise until the top sensor assembly is loose, as shown in [Figure 26a](#).

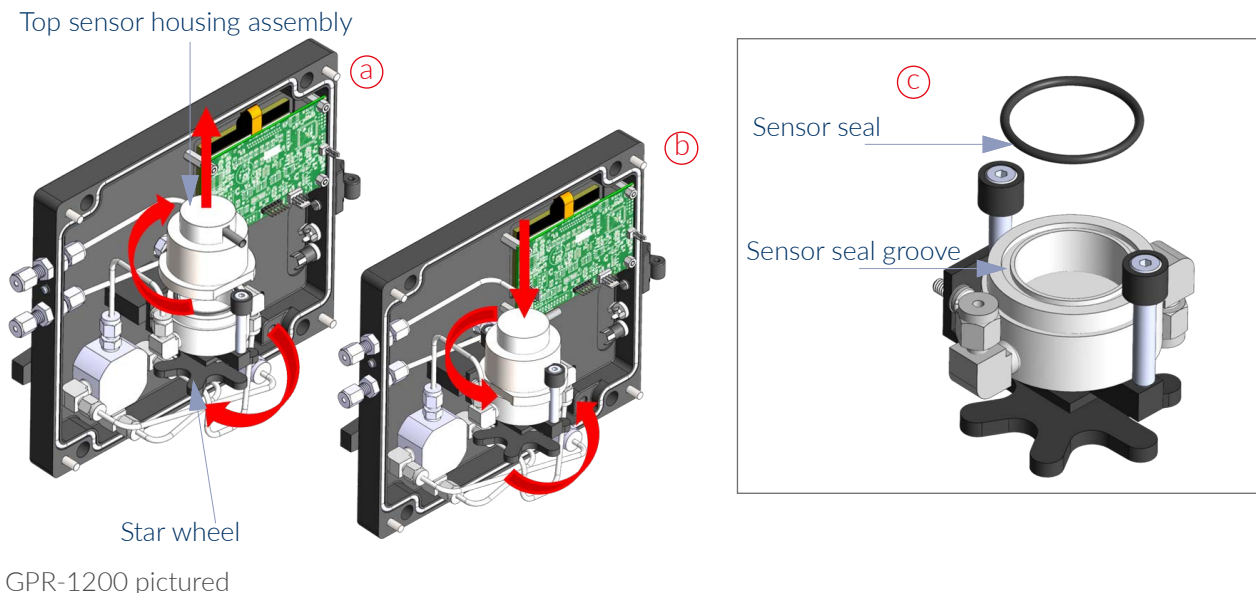

Figure 26. Replacing the sensor seal (GPR-1100 and GPR-1200)

3. Disengage the top sensor assembly by turning it 90° counter-clockwise then pulling it.
4. Using a flat screwdriver, remove the old sensor seal from the sensor housing body and dispose of it.
5. Apply vacuum grease to the new sensor seal then place it in the groove of the sensor housing body as shown in [Figure 26c](#).
6. Position the top sensor assembly, ensuring it is correctly oriented (refer to [Figure 26b](#)), then turn it 90° to re-engage.
7. Secure it using the star wheel.
8. Re-fit the front enclosure, using a flat screwdriver to tighten the enclosure screws.

8.4 Troubleshooting

- Ensure the correct calibration gas is used when performing a validation or calibration of your analyzer. This will prevent unpredictable operation and incorrect readings.
- The calibration gas should be within range of your portable analyzer, typically 100 ppm for the 0...1 % range analyzer, and 20.9 % for the 0...25 %. See the PST Factory calibration certificate supplied with your module for specific calibration gas values.
- A faulty sensor or one that is incorrectly installed will display 'FLT' on your analyzer's display.
- Do not expose the sensor to moisture in a non-powered state. If this happens, allow the sensor to dry out, and if necessary, apply clean dry inert gas:

Table 6: Troubleshooting causes and recommendations

Symptoms	Possible cause	Recommended actions
Slow recovery	At installation, defective sensor	Replace sensor if recovery unacceptable or O ₂ reading fails to reach 10 % of lowest range
	Air leak in sample system connection(s)	Leak test the entire sample system: Vary the flow rate, if the O ₂ reading changes inversely with the change in flow rate indicates an air leak - correct source of leak
	Abnormality in zero gas	Qualify with zero gas Replace sensor
	Damaged in service - prolonged exposure to air, electrolyte leak	Replace sensor
	Sensor nearing end of life	Replace sensor
High O ₂ reading after installing or replacing sensor	Analyzer calibrated before sensor stabilized caused by:	
	Prolonged exposure to ambient air, worse if sensor was left in air un-shorted	Allow O ₂ reading to stabilize before making any calibration adjustment, continue purge with zero gas
	Air leak in sample system connection(s)	Leak test the entire sample system (above)
	Abnormality in zero gas	Qualify with zero gas
High O ₂ reading sampling	Flow rate exceeds limits Pressurized sensor	Correct pressure and flow rate Remove restriction on vent line or open SHUT OFF valve completely
	Improper sensor selection	Replace GPR/PSR sensor with XLT sensor when CO ₂ or acid gases are present. Replace GPR/PSR sensor with -H sensor when H ₂ or He gas is the background gas.
	Abnormality in sample gas measurement	Validate with portable oxygen analyzer
Response time slow	Air leak, dead legs, longer distance of sample line, low flow rate, high volume of optional filters and scrubbers	Leak test sample system bringing sample gas to analyzer, reduce dead volume and/or increase sample flow rate
O ₂ reading doesn't agree with expected O ₂ values	Pressure and temperature of the sample may be different than the span gas used for calibration Abnormality in the sample gas	Calibrate the analyzer (calibrate close to the pressure and temperature of the sample gas)
		Qualify sample gas independently

Symptoms	Possible cause	Recommended actions
Erratic O ₂ reading or No O ₂ reading	Test sensor signal output independent from analyzer	Remove sensor from housing. Using a volt-meter set to uA output; apply the (+) lead to the outer ring of the sensor PCB and the (-) lead to the center circle to obtain the sensor's output in air. If no current signal, replace sensor, otherwise contact the PST Factory.
	Abrupt changes in sample pressure	Regulate sample gas pressure and flow.
	Dirty electrical contacts in upper section of sensor housing	Replace sensor
	Corroded solder joints on sensor PCB from corrosive sample or electrolyte leakage from sensor Corroded spring loaded contact in upper section of sensor housing from liquid in sample or electrolyte leakage from sensor	Clean spring loaded contacts in upper section of sensor housing with a damp cloth or cotton swab, water or IPA can be used. If electrolyte leakage from sensor is evident, replace sensor
	Liquid in sensor housing	Wipe sensor and sensor housing with a damp cloth or cotton swab. Water or IPA can be used.
	Improper sensor selection	Replace GPR/PSR series sensor with XLT sensor when CO ₂ or acid gases are present
	Presence of other interference gases	Consult PST Factory
	Presence of sulfur gases	Replace sensor and install H ₂ S scrubber
	Unauthorized maintenance	Replace sensor, obtain authorized service
Erratic O ₂ reading or Negative O ₂ reading or No O ₂ reading possibly accompanied by electrolyte leakage	Sensor nearing end of life	Replace sensor,
	Pressurizing the sensor by flowing gas to the sensor with the vent restricted	Zero the analyzer. If not successful replace the sensor
	Pressurizing the sensor by flowing gas to the sensor with SHUT OFF valve closed and then suddenly removing the restriction draws a vacuum on the sensor or partially opening the valves upstream of the analyzer when using a pump downstream of the analyzer to draw sample from a process at atmospheric pressure or a slight vacuum A pressurized sensor may not leak but still can produce negative readings. Placing a vacuum on the sensor in excess 40" of water column is strongly discouraged.	Avoid drawing a vacuum on the sensor
	A premature ZERO OFFSET of analyzer	From MAIN MENU select DEFAULT ZERO and perform a zero calibration

9 Warranty information

The design and manufacture of Analytical Industries Inc. oxygen analyzers and oxygen sensors are performed under a certified Quality Assurance System that conforms to established standards and incorporates state of the art materials and components for superior performance and minimal cost of ownership.

Prior to shipment every analyzer is thoroughly tested by the manufacturer and documented in the form of a Quality Control Certification that is included in the Owner's Manual accompanying every analyzer.

When operated and maintained in accordance with the Owner's Manual, the units will provide many years of reliable service.

9.1 Coverage

Under normal operating conditions, the analyzers and sensors are warranted to be free of defects in materials and workmanship for the period specified in accordance with the most recent published specifications, said period begins with the date of shipment by the manufacturer.

The manufacturer information and serial number of this analyzer are located on the rear of the analyzer. Analytical Industries Inc. reserves the right in its sole discretion to invalidate this warranty if the serial number does not appear on the analyzer.

If your PST monitor, analyzer and/or oxygen sensor is determined to be defective with respect to material and/or workmanship, PST will repair it or, at our option, replace it at no charge to you.

This warranty applies to all monitors, analyzers and sensors purchased worldwide.

9.2 Limitations

Analytical Industries Inc. will not pay for: loss of time; inconvenience; loss of use of your Analytical Industries Inc. analyzer or property damage caused by your Analytical Industries Inc. analyzer or its failure to work; any special, incidental or consequential damages; or any damage resulting from alterations, misuse or abuse; lack of proper maintenance; unauthorized repair or modification of the analyzer; affixing of any attachment not provided with the analyzer or other failure to follow the user manual.

US Customers only: Some states and provinces do not allow limitations on the duration of an implied warranty or the exclusion or limitation of special, incidental or consequential damages, in this case, these exclusions may not apply. This warranty gives you specific legal rights. You may have other rights, which vary between states and provinces.

9.3 Exclusions

This warranty does not cover installation; defects resulting from accidents; damage while in transit to our service location; damage resulting from alterations, misuse or abuse; lack of proper maintenance; unauthorized repair or modification of the analyzer; affixing of any label or attachment not provided with the analyzer; fire, flood, or acts of God; or other failure to follow the User Manual.

9.4 Service

For queries related to service and warranty, please contact your local Process Sensing Technologies office, sales partner or supplier.

Offices are listed at ProcessSensing.com or email oxygen@processsensing.com.



10 Appendices

Appendix A - Technical Specifications

Sensor				
	GPR-1100 & GPR-1200		GPR-2000	
	ppm		%	
Model Number	GPR-12-333 GPR-12-333-H	XLT-12-333	GPR-11-60-4	XLT-11-24-4
Measuring Range	0...10, 0...100, 0...1000 ppm _v , 0...1 % 0...25 % (calibration only)		0...1, 0...5, 0...10, 0...25 %	
Accuracy	< 2 % of selected range at constant conditions			
Output Resolution	0.01 ppm _v		0.001 %	
Lower Detection Limit (LDL)	0.05 ppm _v		0.01 %	
Sample Flow Rate	1...2 SCFH (0.5...1 LPM)			
Pressure Range	5...30 psi (0.3...2 bar)			
Response Time (T ₉₀)	< 2 minutes		< 30 seconds	
Operating Temperature Range	+5...+45 °C (+41...+113 °F)	-10...+45 °C (+14...+113 °F)	+5...+45 °C (+41...+113 °F)	-10...+45 °C (+14...+113 °F)
Humidity	0...80 %rh non-condensing			
Life Expectancy (application dependent)	24 months in 1000 ppm _v		60 months in air	24 months in air
Calibration Interval (application dependent)	30 days			
Analyzer				
Electrical				
Display	LCD			
Output Signal	0...1 V DC			
Power Supply (battery charger)	100...240 V AC			
Voltage Output (battery charger)	9 V DC (2 A)			
Power Requirement (battery charger)	18 W			
Mechanical				
Analyzer Housing Material	Painted aluminum			
Compliance				
Complies with EMC Directive: 2014/30/EU				

Appendix B - Hazardous Area Certification

Region	Certification details	Standards
Europe	 ATEX / UKCA II 1 G Ex ia IIC T4 Ga T _{amb} (-20 °C...+50 °C)	EN 60079-0:2018 EN 60079-1:2014 EN 60079-11:2012
North America/Canada	 cMETus Class I, Division 1, Groups A, B, C & D, T4 Class I, Zone 0, AEx ia IIC T4 Ga T _{amb} (-20 °C...+50 °C)	UL 60079-0:2019 (R2020) UL 60079-1:2020 UL 60079-11:2013 (R2018) UL 1203:2022 UL 61010-1:2019 CSA C22.2 No. 60079-0:2019 CSA C22.2 NO. 60079-1:16 (R2021) CSA C22.2 No. 60079-11:2014 (R2018) CSA C22.2 NO. 30:20 CSA C22.2 No. 61010-1:2017
International	 IECEx Ex ia IIC T4 Ga T _{amb} (-20 °C...+50 °C)	IEC 60079-0:2017 IEC 60079-1:2014 IEC 60079-11:2011

Appendix C - Safety Data Sheet



Analytical Industries Inc.

A PST Brand

Safety Data Sheet (KOH)

I. Product Identification

Product Name: Oxygen Sensor (Series AII, GPR, PSR, Private Label derivations)
Product Use: Oxygen Sensors
Manufacturer: Analytical Industries Inc.
Address: 2855 Metropolitan Place, Pomona, CA 92767 USA
Contact Information: Tel: 909-392-6900, Fax: 909-392-3665, email: info@aii1.com
Emergency Number:

Date Prepared: January 1, 1995
Date Revised: January 31, 2023

II. Hazardou(s) Identification

GHS Classification:
Lead (Pb)

Health

Acute Toxicity- Category (Inhalation)
 Acute Toxicity- Category 4 (oral/dermal)
 Carcinogenic- Category 2ty
 Reproductive/Developmental- Category 2
 Target organ Toxicity (Repeated) Category 2

Environmental

Acute Aquatic Toxicity-Cat
 Chronic Aquatic Toxicity-Category 1

Physical

NA

Potassium Hydroxide (KOH)

Health

Corrosive to Metal- Category 1
 Acute Toxicity- Category 4 (oral)
 Skin Corrosion-Category 1A
 Serious Eye Damage-Category 1

Environmental

Acute Aquatic Toxicity-Cat

Physical

NA

GHS Labels:

Potassium Hydroxide (KOH)

Symbols:



Hazardous Statements

- Danger
- May be corrosive to metal
- Harmful if swallowed
- Causes severe skin burns and eye damage
- Harmful to aquatic life

Precautionary Statements

- Wash skin thoroughly after handling.
- Do not eat, drink or smoke when using this product.
- Avoid release to the environment.
- Wear protective gloves/ protective clothing/ eye protection/ face protection.
- IF SWALLOWED: Call a POISON CENTER or doctor/ physician if you feel unwell.
- IF SWALLOWED: Rinse mouth. Do NOT induce vomiting.
- IF ON SKIN (or hair): Remove/Take off immediately all contaminated clothing. Rinse skin with water/ shower.
- IF INHALED: Remove victim to fresh air and keep at rest in a position comfortable for breathing.
- IF IN EYES: Rinse cautiously with water for several minutes. Remove contact lens if present and easy to do. Continue rinsing. Immediately call a POISON CENTER or doctor/ physician.
- Wash contaminated clothing before reuse.
- Absorb spillage to prevent material damage.
- Store in corrosive resistant stainless steel container with a resistant inner liner.
- Dispose of contents/ container to an approved waste disposal plant.

GHS Labels:

Lead (Pb)



Analytical Industries Inc.

A PST Brand

Safety Data Sheet (KOH)

Symbols:



Hazardous Statements

- Warning !
- Harmful if swallowed
- Suspected of causing cancer.
- Suspected of damaging fertility or the unborn child.
- May cause damage to organs through prolonged or repeated exposure.
- Very toxic to aquatic life with long lasting effects.

Precautionary Statements

- If breathed in, move person into fresh air. In not breathing, give artificial respiration. Consult a physician.
- In case of skin contact, wash off with soap and plenty of water.
- In case of eye contact, flush eyes with water as a precaution.
- If swallowed, rinse mouth with water.

III. Composition /Information on Ingredients

Material	C.A.S. #	Weight %	GHS Classification	Notes
Lead (Pb)	7439-92-1	50-75	Carc 1A;H350 Aquatic Acute 1:H400	Substance classified with a health & Environmental hazard. Substance with a work place limit
Potassium Hydroxide (KOH)	1310-58-3	1.0-10	Acute Tox. 4; H302 Skin Corr.1A; H314	Substance classified with a health & Environmental hazard. Substance with a work place limit.

IV. First Aid Measures

4.1. Description of aid measures

General:

- In all cases of doubt, or when symptoms persist, seek medical attention. Never give anything by mouth to an unconscious person.

Inhalation:

- Remove to fresh air, keep patient warm and at rest. If breathing is irregular or stopped, give artificial respiration. If unconscious place in the recovery position and obtain immediate

Eyes:

- Irrigate copiously with clean water for at least 15 minutes, holding the eyelids apart and seek medical attention.

Skin:

- Remove contaminated clothing. Wash skin thoroughly with soap and water or use a recognized skin cleanser.

Ingestion:

- Do NOT induce vomiting. Rinse mouth and slowly drink several glasses of water. Call a physician. Do NOT give anything by mouth to an unconscious or

4.2. Most important symptoms and effects, both acute and delayed

- The most important known symptoms and effects are described in the labelling (see section II) and/or in section XI

V. Fire -Fighting Measures

5.1. Extinguishing media

- Use standard fire fighting media on surrounding materials including water spray, foam, and carbon dioxide. (Do not use dry chemical extinguisher

5.2. Special hazards arising from the substance or mixture

- Lead Oxides.

5.3. Advice for fire-fighters

- Wear self-contained breathing apparatus for firefighting if necessary.



Analytical Industries Inc.

A PST Brand

Safety Data Sheet (KOH)

5.4. Further Information

- Gives off hydrogen by reaction with metals.

VI. Accidental release measures

Note: The Oxygen sensor contains a strong basic solution encapsulated in a plastic housing. Under normal operating conditions the solution (electrolyte) is never exposed. In case of a leak please observe the following instructions:

6.1. Personal precautions, protective equipment and emergency procedures

- Use appropriate personal protective equipment. Avoid dust formation. Avoid breathing vapors, mist or gas. Ensure adequate ventilation. Evacuate personnel to safe areas. Avoid breathing dust. For personal protection see section

6.2. Environmental precautions

- Do not allow spills to enter drains or waterways. Use good personal hygiene practices. Wash hands before eating, drinking, smoking or using toilet. Promptly remove soiled clothing and wash thoroughly before reuse.

6.3. Methods and material for containment and cleaning up

- Contain spillage. Neutralize spill with soda ash or lime. Carefully place material into clean dry contain and cover. Flush spill area with water. Avoid creating dust.

VII. Handling and storage

7.1. Precautions for safe handling

- Under normal circumstances the lead anode and potassium hydroxide electrolyte are sealed inside the oxygen sensor which is then sealed in a polyethylene bag and placed in a cardboard box for shipment) and do not present a health hazard. The following guidelines are provided in the event an oxygen sensor leaks
- Before opening the bag containing the sensor cell, check the sensor cell for leakage. If the sensor cell leaks, do not open the bag. If there is liquid around the cell while in the instrument, put on gloves and eye protection before removing the

7.2. Conditions for safe storage, including any incompatibilities

- Store sensors in a cool ,dry and well-ventilated places. Exercise due caution to prevent damage to or leakage from the container. Keep containers closed when

7.3. Specific end use(s)

- Apart from the uses mentioned in section I no other specifies are stipulated.

VIII. Exposure Controls/Personal Protection

8.1. Control parameters

Exposure

<u>CAS No.</u>	<u>Ingredient</u>	<u>Source</u>	<u>Value</u>
0001310-58-3	Potassium hydroxide	OSHA ACGIH NIOSH Supplier	No Establish Limits Ceiling: 2mg/m3 Ceiling: 2mg/m3
007439-92-1	Lead (Pb)	OSHA ACGIH NIOSH Supplier	No Establish Limits (1910.1025)TWA 0.050mg/m3 TWA:0.05 mg/m3R,2B,2A TWA (8 Hour)0.050 mg/m3 No Establish Limits

Carcinogen Data

<u>CAS No.</u>	<u>Ingredient</u>	<u>Source</u>	<u>Value</u>
0001310-58-3	Potassium hydroxide	OSHA NTP IARC	Select Carcinogen: No Known: No; Suspected: No Group 1: No; Group 2a: No; Group 2b: No; Group 3: No; Group 4: No;
007439-92-1	Lead (Pb)	OSHA	Select Carcinogen: Yes



Analytical Industries Inc.

A PST Brand

Safety Data Sheet (KOH)

NTP Known: No; Suspected: Yes
 Group 1: No; Group 2a: No;
 IARC Group 2b: Yes; Group 3: No;
 Group 4: No;

**8.2. Exposure controls
Respiratory**

- If workers are exposed to concentrations above the exposure limit they must use the appropriate, certified respirators.

Eyes

- Chemical splash goggles

Skin

- Apron, face shield Wear gloves. Gloves must be resistant to corrosive materials. Nitrile or PVC gloves are suitable. Do not use cotton or leather gloves.

Engineering Controls

- Provide adequate ventilation. Where reasonably practicable this should be achieved by the use of local exhaust ventilation and good general extraction. If these are not sufficient to maintain concentrations of particulates and any vapor below occupational exposure limits suitable respiratory protection must be worn.

Other Work Practices

- Use good personal hygiene practices. Wash hands before eating, drinking, smoking or using toilet. Promptly remove soiled clothing and wash thoroughly

IX. Physical / Chemical Characteristics

9.1 Information on basic physical and chemical properties

Material / Component:	<u>Lead (Pb) - Anode</u>	<u>Potassium Hydroxide (KOH) - Electrolyte</u>
Appearance	Article Solid	Form: Liquid; Color: Clear Translucent
Odor	None	None
Odor threshold	Not Measured	Not Measured
pH	Not Measured	>13
Melting point / freezing point	>328° C	Not Measured
Initial boiling point and boiling range	>1320° C	Not Measured
Flash Point	Not Measured	>100° C
Evaporation rate (Ether = 1)	Not Measured	Not Measured
Flammability (solid, gas)	Not Applicable	Not Measured
Upper/lower flammability or explosive limits	Not Measured	Not Measured
Vapor pressure	Not Measured	Not Measured
Vapor Density	Not Measured	Not Measured
Specific Gravity	Not Measured	Not Measured
Solubility in Water	Insoluble	100% (Water based solution)
Partition coefficient n-octanol/water (Log Kow)	Not Measured	Not Measured
Auto-ignition temperature	Not Measured	Not Measured
Decomposition temperature	Not Measured	Not Measured
Viscosity (cSt)	Not Measured	Not Measured

9.2. Other information

No other relevant information.

X. Stability and Reactivity

10.1. Reactivity

- Hazardous Polymerization will not occur

10.2. Chemical stability

- Stable under normal circumstances

10.3. Possibility of hazardous reactions

- Incompatible with strong oxidizers, leather and halogenated compounds. Product will react with 'soft' metals such as aluminum, tin, magnesium, and zinc



Analytical Industries Inc.

A PST Brand

Safety Data Sheet (KOH)

10.4. Conditions to avoid

releasing flammable hydrogen gas.

- Excessive heat and open flame.

10.5. Incompatible materials

- Aluminum, organic materials, acid chlorides, acid anhydrides, magnesium, copper. Avoid contact with acids and hydrogen peroxide >52%

10.6. Hazardous decomposition products

- Toxic fumes.

XI. Toxicological Information

11.1 Information on toxicological effects (Potassium Hydroxide)

Acute toxicity

- LD50 Oral - Rat- 333mg/kg
- Inhalation : no data available
- Dermal: no data available

Skin Corrosion/irritation

- Skin Rabbit- Severe skin irritation 24 h

Serious eye damage/eye irritation

- Eyes Rabbit- Corrosive to eyes (OECD Test Guideline 405)

Respiratory or skin sensitization

- No Data Available

Germ cell mutagenicity

- No Data Available

Carcinogenicity

IARC • No component of this product presents at levels greater than or equal to 0.1% is identified as probable, possible or confirmed human carcinogen by IARC.

ACGIH • No component of this product presents at levels greater than or equal to 0.1% is identified as a carcinogen or potential carcinogen by ACGIH.

NTP • No component of this product presents at levels greater than or equal to 0.1% is identified as a known or anticipated carcinogen by NTP

OSHA • No component of this product presents at levels greater than or equal to 0.1% is identified as a carcinogen or potential carcinogen by OSHA

Reproductive toxicity

- No Data Available

Specific target organ toxicity-single exposure

- No Data Available

Specific target organ toxicity-repeated exposure

- No Data Available

Additional information

- RTECS:TT2100000

11.2 Information on toxicological effects (Lead)

Acute toxicity

- Inhalation : no data available
- Dermal: no data available

Skin Corrosion/irritation

- No Data Available

Serious eye damage/eye irritation

- No Data Available

Respiratory or skin sensitization

- No Data Available

Germ cell mutagenicity

- Rat - Cytogenetic analysis



Analytical Industries Inc.

A PST Brand

Safety Data Sheet (KOH)

- Carcinogenicity**
 - Limited evidence of carcinogenicity in animal studies
 - IARC** • 2B-Group 2B. Possibly carcinogenic to humans (Lead)
 - NTP** • Reasonably anticipated to be a human carcinogen (Lead)
 - OSHA** • 1910.1025 (Lead)
- Reproductive toxicity**
 - Suspected human reproductive toxicant
 - Rat-Inhalation: Effects on Newborn; Biochemical metabolic
 - Rat-Oral: Effects on Newborn; Behavioral
 - Mouse-Oral: Effect on Fertility: Female fertility index (e.g., # females pregnant per # sperm positive females; # females pregnant per # females mated). Effects on Fertility: Pre-implantation mortality (e.g., reduction in number of implants per female; total number of implants per corpora lutea).
- Development Toxicity**
 - Rat-Inhalation: Effects on Embryo or Fetus: Fetotoxicity (except death, e.g., stunted fetus). Specific Developmental Abnormalities: Blood and lymphatic system (including spleen and marrow).
 - Rat-Oral: Specific Developmental Abnormalities: Blood and lymphatic system (including spleen and marrow). Effects on Newborn: Growth statistics (e.g.,
 - Rat-Oral: Effects on Embryo or Fetus: Fetotoxicity (except death, e.g., stunted fetus). Effects on Embryo or Fetus: Fetal death.
 - Mouse-Oral: Effects on Embryo or Fetus: Fetotoxicity (except death, e.g., stunted fetus). Effects on Embryo or Fetus: Fetal death.
- Specific target organ toxicity – single exposure**
 - No Data Available
- Specific target organ toxicity – repeated exposure**
 - May cause damage to organs through prolonged or repeated exposure.
- Aspiration hazard**
 - No Data Available
- Additional Information**
 - RTECS: OF7525000

XII. Ecological Information

12.1. Toxicity
 Very toxic to aquatic life
Aquatic Ecotoxicity

Ingredient	96 hr. LC50 fish, mg/l	48 hr. EC50 crustacea, mg/l	ErC50 algae, mg/l
Lead Compounds (as Pb) - (7439-92-1)	0.44, Cyprinus carpio	4.40, Daphnia magna	0.25 (72 hr.), Scenedesmus subspicatus
Potassium hydroxide. - (1310-58-3)	Not Available	Not Available	Not Available

- 12.1. Persistence and degradability**
 - There is no data available on the preparation itself.
- 12.3. Bioaccumulative potential**
 - Not Measured
- 12.4. Mobility in soil**
 - No Data Available
- 12.5. Result of PBT and vPvB assessment**
 - This Product contains no PBT and vPvB chemicals.
- 12.6. Other adverse effects**
 - Lead is bioaccumulative in most aquatic life and mammals. It is highly mobile as lead dust or fume, yet forms complexes with organic material which limits its

XIII. Disposal Considerations



Analytical Industries Inc.

A PST Brand

Safety Data Sheet (KOH)

13.1. Waste treatment methods

- Do not allow into drains or water courses. Wastes and emptied containers should be disposed of in accordance with regulations made under the Control of Pollution Act and the Environmental Protection Act.
- Using information provided in this data sheet advice should be obtained from the Waste Regulation Authority, whether the special waste regulations apply.

XIV. Transport Information

DOT:

- Regulated. Refer to Small Quantity Exceptions: 49 CFR 173.4
- UN3266, Corrosive liquid, basic, inorganic, n.o.s., (potassium hydroxide, lead), 8, II NOTE: This description is used for shipping purposes when not using Analytical Industries Inc. US DOT Approval.
- UN3363, Dangerous Goods in Machinery or Dangerous Goods in Apparatus, 9. NOTE: This description is used when shipping under the US DOT Approval.

IATA:

- Regulated. Meets criteria for IATA Dangerous Goods in Excepted Quantities, Secti

Environmental hazards IMDG

- Marine Pollutant: Yes (Lead Compounds (as Pb))

XV. Regulatory Information

Regulatory Overview

- The regulatory data in Section 15 is not intended to be all-inclusive, only selected regulations are represented.

Toxic Substance Control Act (TSCA)

- All components of this material are either listed or exempt from listing on the TSCA Inventory

WHMIS Classification

- D2A E

US EPA Tier II Hazards

Fire: No
Sudden Release of Pressure: No
Reactive: No
Immediate (Acute): Yes
Delayed (Chronic): Yes

EPCRA 311/312 Chemicals and RQs (lbs.):

- Lead Compounds (as Pb) (10.00)
- Potassium hydroxide. (1,000.00)

EPCRA 302 Extremely Hazardous :

- (No Product Ingredients Listed)

EPCRA 313 Toxic Chemicals:

- Lead Compounds (as Pb)

Proposition 65 - Carcinogens (>0.0%):

- Lead Compounds (as Pb)

Proposition 65 - Developmental Toxins (>0.0%):

- Lead Compounds (as Pb)

Proposition 65 - Female Repro Toxins (>0.0%):

- Lead Compounds (as Pb)

Proposition 65 - Male Repro Toxins (>0.0%):

- Lead Compounds (as Pb)

N.J. RTK Substances (>1%):

- Lead Compounds (as Pb)
- Potassium hydroxide.

XVI. Other Information

The information and recommendations contained herein are based upon data believed to be correct. However, no guarantee or warranty of

**Analytical Industries Inc.**

A PST Brand

Safety Data Sheet (KOH)

any kind, expressed or implied, is made with respect to the information contained herein. We accept no responsibility and disclaim all liability for any harmful effects which may be caused by exposure to our products. Customers/users of this product must comply with all applicable health and safety laws, regulations, and orders.

H302 Harmful if swallowed.

H314 Causes severe skin burns and eye damage.

H350 May cause cancer.

H400 Very toxic to aquatic life.

This is the first version in the GHS SDS format. Listings of changes from previous versions in other formats are not

All chemicals may pose unknown hazards and should be used with caution. While the information contained in this Material Safety Data Sheet is believed to be correct and is offered for your information, consideration and investigation, Analytical Industries Inc assumes no responsibility of the completeness or accuracy of the information contained herein.

End of Document

Appendix D - Controlled Drawings

4	3	2	1																																	
<p>THE PORTABLE GAS ANALYZER IS NOT CAPABLE OF WITHSTANDING THE 500V INSULATION DIELECTRIC STRENGTH TEST REQUIRED BY IEC 60079-11. THIS SHALL BE TAKEN INTO ACCOUNT WHEN INSTALLING THE EQUIPMENT.</p> <p>THE INSTALLATION MUST COMPLY WITH THE INSTALLATION PRACTICES OF THE COUNTRY OF USE, I.e. THE NATIONAL ELECTRICAL CODE ANSI/NFPA 70 AND THE CANADIAN ELECTRICAL CODE CSA C22.1.</p>		<p>PRODUCT MODEL NUMBER: GPR-1000, GPR-1100, GPR-1200 GPR-1200 MS2, GPR-2000, GPR-7100</p> <p>EQUIPMENT TYPE ID: PORTABLE GAS ANALYZER</p> <p>CERTIFICATE NUMBER: E115647</p> <p>DIVISION SYSTEM MARKING: Class I Div 1 Groups ABCD, T4</p> <p>ZONE SYSTEM MARKING: Class I Zone 0 AEx ia IIC T4 Ga</p> <p>IEC / CANADA: Ex ia IIC T4 Ga</p>																																		
<p>HAZARDOUS AREA INSTALLATIONS</p> <p>1. PARAMETERS TABLE FOR NON-INTRINSICALLY SAFE BATTERY CHARGER CONNECTION:</p> <table border="1" style="width:100%; border-collapse: collapse;"> <tr> <th>GROUP</th> <th>U_i / U_m (V)</th> </tr> <tr> <td>B or IIC</td> <td rowspan="3" style="text-align:center;">9.45</td> </tr> <tr> <td>C ou IIB</td> </tr> <tr> <td>D ou IIA</td> </tr> <tr> <td colspan="2">OTHER PARAMETERS ARE DETERMINED BY THE CONNECTED EQUIPMENT</td> </tr> </table>		GROUP	U _i / U _m (V)	B or IIC	9.45	C ou IIB	D ou IIA	OTHER PARAMETERS ARE DETERMINED BY THE CONNECTED EQUIPMENT																												
GROUP	U _i / U _m (V)																																			
B or IIC	9.45																																			
C ou IIB																																				
D ou IIA																																				
OTHER PARAMETERS ARE DETERMINED BY THE CONNECTED EQUIPMENT																																				
<p>PARAMETERS TABLE FOR ANALOG OUTPUT:</p> <table border="1" style="width:100%; border-collapse: collapse;"> <tr> <th>GROUP</th> <th>U_i/U_m (V)</th> <th>U_o (V)</th> <th>I_o (mA)</th> <th>P_o (mW)</th> <th>C_i (nF)</th> <th>C_o (nF)</th> <th>L_o (H)</th> <th>L_o/R_o (μH/Ω)</th> </tr> <tr> <td>B or IIC</td> <td rowspan="3" style="text-align:center;">28</td> <td rowspan="3" style="text-align:center;">4.6</td> <td rowspan="3" style="text-align:center;">2</td> <td rowspan="3" style="text-align:center;">2</td> <td rowspan="3" style="text-align:center;">12</td> <td style="text-align:center;">71</td> <td style="text-align:center;">8.8</td> <td style="text-align:center;">15,000</td> </tr> <tr> <td>C or IIB</td> <td style="text-align:center;">638</td> <td style="text-align:center;">35</td> <td style="text-align:center;">61,000</td> </tr> <tr> <td>D or IIA</td> <td style="text-align:center;">2138</td> <td style="text-align:center;">71</td> <td style="text-align:center;">123,000</td> </tr> <tr> <td colspan="9">OTHER PARAMETERS ARE DETERMINED BY THE CONNECTED EQUIPMENT</td> </tr> </table>		GROUP	U _i /U _m (V)	U _o (V)	I _o (mA)	P _o (mW)	C _i (nF)	C _o (nF)	L _o (H)	L _o /R _o (μH/Ω)	B or IIC	28	4.6	2	2	12	71	8.8	15,000	C or IIB	638	35	61,000	D or IIA	2138	71	123,000	OTHER PARAMETERS ARE DETERMINED BY THE CONNECTED EQUIPMENT								
GROUP	U _i /U _m (V)	U _o (V)	I _o (mA)	P _o (mW)	C _i (nF)	C _o (nF)	L _o (H)	L _o /R _o (μH/Ω)																												
B or IIC	28	4.6	2	2	12	71	8.8	15,000																												
C or IIB						638	35	61,000																												
D or IIA						2138	71	123,000																												
OTHER PARAMETERS ARE DETERMINED BY THE CONNECTED EQUIPMENT																																				
<p>2. BATTERY CHARGER/SD CARD CONNECTION CAN ONLY BE USED IN NON-HAZARDOUS LOCATION.</p> <p>3. WARNING: SUBSTITUTION OF COMPONENTS MAY IMPAIR INTRINSIC SAFETY.</p> <p>4. ALL CABLE MUST BE SHIELDED TO GROUND AT CUSTOMER SIDE.</p>		<p>UNLESS OTHERWISE SPECIFIED:</p> <p>DIMENSIONS ARE IN INCHES</p> <p>TOLERANCES: FRACTIONAL 1/16 ANGULAR - MATCH ± 1/2 BEND ± 2 TWO PLACE DECIMAL .500 THREE PLACE DECIMAL .005</p> <p>INTERPRET GEOMETRIC TOLERANCING PER ANSI Y14.5</p> <p>MATERIAL: FRESH</p> <p>DO NOT SCALE DRAWING</p> <table border="1" style="width:100%; border-collapse: collapse;"> <tr> <th>NAME</th> <th>DATE</th> </tr> <tr> <td>DRAWN: EW</td> <td>07/10/23</td> </tr> <tr> <td>CHECKED:</td> <td></td> </tr> <tr> <td>AVG APPR:</td> <td></td> </tr> <tr> <td>G.A.:</td> <td></td> </tr> <tr> <td>COMMENTS:</td> <td></td> </tr> </table> <p>ANALYTICAL INDUSTRIES INC.</p> <p>TITLE: PORTABLE GAS ANALYZER SYSTEM DRAWING</p> <p>SIZE DWG. NO. REV</p> <p>B A-5592-EX 0</p> <p>SCALE: WEIGHT: SHEET 1 OF 2</p>		NAME	DATE	DRAWN: EW	07/10/23	CHECKED:		AVG APPR:		G.A.:		COMMENTS:																						
NAME	DATE																																			
DRAWN: EW	07/10/23																																			
CHECKED:																																				
AVG APPR:																																				
G.A.:																																				
COMMENTS:																																				
4	3	2	1																																	

4	3	2	1																																	
<p>L'ANALYSEUR DE GAZ PORTABLE N'EST PAS CAPABLE DE SUPPORTER UN TEST DE RIGIDITE DIELECTRIQUE DE 500 V EXIGE PAR LA NORME IEC 60079-11 L'ESSAI DE RIGIDITE DIELECTRIQUE DE 500V EXIGE PAR LA NORME IEC 60079-11, IL CONVIENT D'EN TENIR COMPTE LORS DE L'INSTALLATION DE L'EQUIPEMENT.</p> <p>L'INSTALLATION DOIT ETRE CONFORME AUX PRATIQUES D'INSTALLATION DU PAYS D'UTILISATION, C'EST-A-DIRE LE CODE ELECTRIQUE NATIONAL ANSI/ NFPA 70 ET LE CODE ELECTRIQUE CANADIEN CSA C22.1.</p>		<p>NUMÉRO DE MODÈLE DU PRODUIT: GPR-1000, GPR-1100, GPR-1200 GPR-1200 MS2, GPR-2000, GPR-7100</p> <p>TYPE D'ÉQUIPEMENT ID : ANALYSEUR DE GAZ PORTABLE</p> <p>NUMÉRO DE CERTIFICAT: E115647</p> <p>MARQUAGE DU SYSTÈME DE DIVISION: Class I Div 1 Groups ABCD, T4 ZONE</p> <p>MARQUAGE DU SYSTÈME: Class I Zone 0 AEx ia IIC T4 Ga</p> <p>IEC / CANADA: Ex ia IIC T4 Ga</p>																																		
<p>INSTALLATIONS EN ZONE DANGEREUSE</p> <p>TABLEAU DES PARAMÈTRES POUR LA CONNEXION D'UN CHARGEUR DE BATTERIE À SÉCURITÉ NON INTRINSÈQUE</p> <table border="1" style="width:100%; border-collapse: collapse;"> <tr> <th>GRUPE</th> <th>U_i / U_m (V)</th> </tr> <tr> <td>B ou IIC</td> <td rowspan="3" style="text-align:center;">9.45</td> </tr> <tr> <td>C ou IIB</td> </tr> <tr> <td>D ou IIA</td> </tr> <tr> <td colspan="2">LES AUTRES PARAMÈTRES SONT DÉTERMINÉS PAR L'ÉQUIPEMENT CONNECTÉ</td> </tr> </table>		GRUPE	U _i / U _m (V)	B ou IIC	9.45	C ou IIB	D ou IIA	LES AUTRES PARAMÈTRES SONT DÉTERMINÉS PAR L'ÉQUIPEMENT CONNECTÉ																												
GRUPE	U _i / U _m (V)																																			
B ou IIC	9.45																																			
C ou IIB																																				
D ou IIA																																				
LES AUTRES PARAMÈTRES SONT DÉTERMINÉS PAR L'ÉQUIPEMENT CONNECTÉ																																				
<p>TABLEAU DES PARAMÈTRES POUR LES SORTIES ANALOGIQUES :</p> <table border="1" style="width:100%; border-collapse: collapse;"> <tr> <th>GRUPE</th> <th>U_i/U_m (V)</th> <th>U_o (V)</th> <th>I_o (mA)</th> <th>P_o (mW)</th> <th>C_i (nF)</th> <th>C_o (nF)</th> <th>L_o (H)</th> <th>L_o/R_o (μH/Ω)</th> </tr> <tr> <td>B ou IIC</td> <td rowspan="3" style="text-align:center;">28</td> <td rowspan="3" style="text-align:center;">4.6</td> <td rowspan="3" style="text-align:center;">2</td> <td rowspan="3" style="text-align:center;">2</td> <td rowspan="3" style="text-align:center;">12</td> <td style="text-align:center;">71</td> <td style="text-align:center;">8.8</td> <td style="text-align:center;">15,000</td> </tr> <tr> <td>C ou IIB</td> <td style="text-align:center;">638</td> <td style="text-align:center;">35</td> <td style="text-align:center;">61,000</td> </tr> <tr> <td>D ou IIA</td> <td style="text-align:center;">2138</td> <td style="text-align:center;">71</td> <td style="text-align:center;">123,000</td> </tr> <tr> <td colspan="9">LES AUTRES PARAMÈTRES SONT DÉTERMINÉS PAR L'ÉQUIPEMENT CONNECTÉ</td> </tr> </table>		GRUPE	U _i /U _m (V)	U _o (V)	I _o (mA)	P _o (mW)	C _i (nF)	C _o (nF)	L _o (H)	L _o /R _o (μH/Ω)	B ou IIC	28	4.6	2	2	12	71	8.8	15,000	C ou IIB	638	35	61,000	D ou IIA	2138	71	123,000	LES AUTRES PARAMÈTRES SONT DÉTERMINÉS PAR L'ÉQUIPEMENT CONNECTÉ								
GRUPE	U _i /U _m (V)	U _o (V)	I _o (mA)	P _o (mW)	C _i (nF)	C _o (nF)	L _o (H)	L _o /R _o (μH/Ω)																												
B ou IIC	28	4.6	2	2	12	71	8.8	15,000																												
C ou IIB						638	35	61,000																												
D ou IIA						2138	71	123,000																												
LES AUTRES PARAMÈTRES SONT DÉTERMINÉS PAR L'ÉQUIPEMENT CONNECTÉ																																				
<p>2. LE CHARGEUR DE BATTERIE/LA CONNEXION DE LA CARTE DD NE PEUT ÊTRE UTILISÉ QUE DANS UN ENDROIT NON DANGEREUX.</p> <p>3. AVERTISSEMENT : LA SUBSTITUTION DE COMPOSANTS PEUT NUIRE À LA SÉCURITÉ INTRINSÈQUE.</p> <p>4. TOUS LES CÂBLES DOIVENT ÊTRE BLINDÉS JUSQU'À LA TERRE PAR LE CLIENT.</p>		<p>SANS INDICATION CONTRAIRE: LES DIMENSIONS SONT EXPRIMÉES EN POUCES, AVEC DES TOLERANCES: VÉRIFIÉ FRACTIONNELLES 1/16 ANGULAR - MATCH ± 1/2 BEND ± 2 DECIMALE A DEUX PLACES ± 0.05 DECIMALE A TROIS PLACES ± 0.005</p> <p>INTERPRÉTER LE SYMBOLOGE DE TOLÉRANCE SELON ANSI Y14.5</p> <p>MATÉRIAU: FRESH</p> <p>NE PAS METTRE LE DESSIN À L'ÉCHELLE</p> <table border="1" style="width:100%; border-collapse: collapse;"> <tr> <th>NOM</th> <th>DATE</th> </tr> <tr> <td>TRACÉ: EW</td> <td>07/10/23</td> </tr> <tr> <td>VÉRIFIÉ:</td> <td></td> </tr> <tr> <td>ENG APPR:</td> <td></td> </tr> <tr> <td>AVG APPR:</td> <td></td> </tr> <tr> <td>G.A.:</td> <td></td> </tr> <tr> <td>COMMENTAIRES:</td> <td></td> </tr> </table> <p>ANALYTICAL INDUSTRIES INC.</p> <p>TITRE: ANALYSEUR DE GAZ PORTABLE SCHEMA DU SYSTEME</p> <p>TAILLE DWG. NO. REV</p> <p>B A-5592-EX 0</p> <p>ÉCHELLE: POIDS: FICHE 1 SUR 2</p>		NOM	DATE	TRACÉ: EW	07/10/23	VÉRIFIÉ:		ENG APPR:		AVG APPR:		G.A.:		COMMENTAIRES:																				
NOM	DATE																																			
TRACÉ: EW	07/10/23																																			
VÉRIFIÉ:																																				
ENG APPR:																																				
AVG APPR:																																				
G.A.:																																				
COMMENTAIRES:																																				
4	3	2	1																																	

Appendix E - Dimensions

GPR-1100

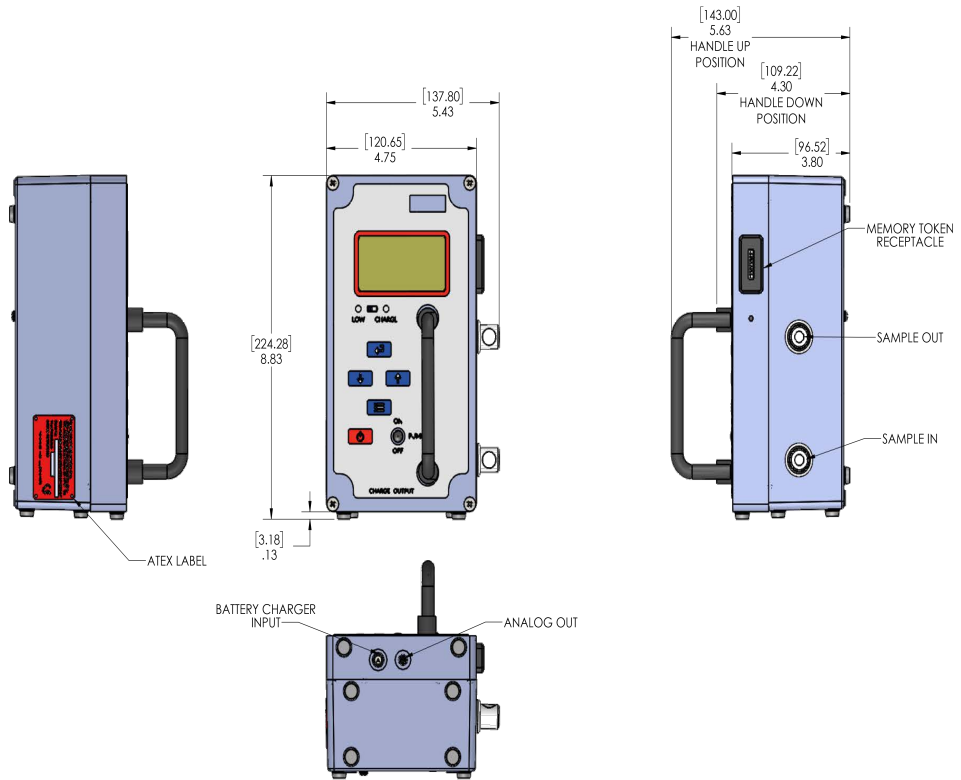

GPR-1200

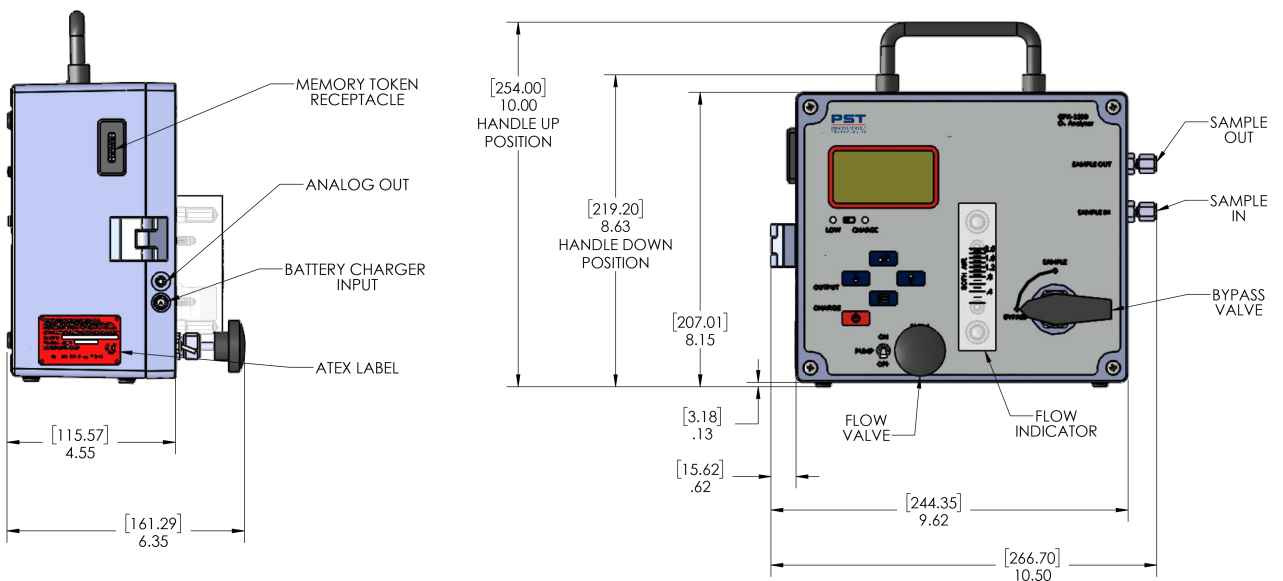

GPR-2000

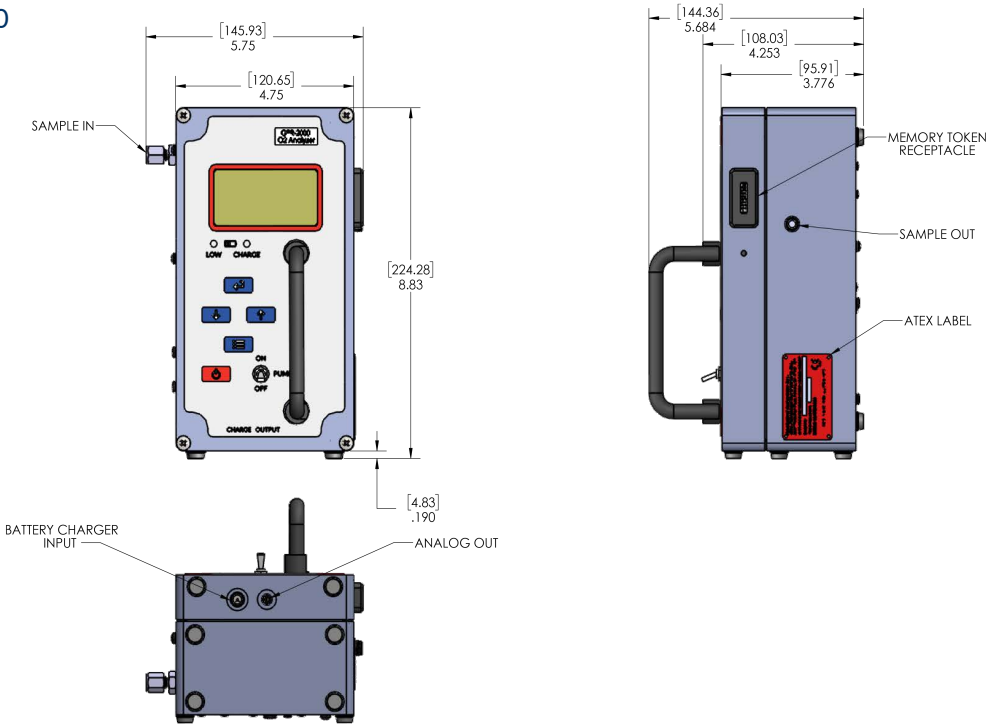

Appendix F - Menu Displays

```

MAIN MENU
> RANGE=AUTO
  CALIBRATION
  DATA LOGGING=OFF
  SYSTEM
  INFO
    
```

```

RANGE
> AUTO/FIXED
  0-10 PPM
  0-100 PPM
  0-1000 PPM
  0-1%
  0-25% AIR CAL
  DEF RANGE=OFF
    
```

```

DEFAULT RANGE
> OFF/ON
  0-10 PPM
  0-100 PPM
  0-1000 PPM
  0-1%
  0-25%
  AUTO
    
```

```

CALIBRATION
> SENSOR SN=000000123
  SPAN CALIBRATE
  ZERO CALIBRATE
  CALIBRATION LOG
  RESET CALIBRATION
    
```

```

SENSOR SN
  000000123
  ▲▼ EDIT
≡ ABORT      ↵ NEXT
    
```

```

SYSTEM
> SECURITY
  CALIBRATE 0-1V
  SIGNAL AVG=1
  CLIPPING=ON/OFF
  TIME=00:00
  DATE FORM=MM/DD/YYYY
  DATE=00/00/0000
    
```

```

SECURITY
> LOCK NOW
  SET PASSCODE
  AUTO LOCK=OFF
    
```

```

CALIBRATE 0-1V
  ADJUST OUTPUT TO 0V
  REF: 0
  ▲▼ EDIT
≡ ABORT      ↵ 1V
    
```

```

SIGNAL AVG
  1 . . 100
  001
  ▲▼ EDIT
≡ ABORT      ↵ next
    
```

```

SYSTEM
> RANGE SCALE=1
  UNIT ID=
  FACTORY RESET
    
```

```

INFO
  UNIT ID=
  ANA SN=000000000
  PCB SN=000000000
  FIRM=S1013 1.07
  CONFIG=PORT 02-1
    
```

NOTE: The menu structure may vary depending on your configuration.

Appendix G - Spare Parts

		GPR-1100	GPR-1200	GPR-2000
Sensors				
GPR-12-333	ppm Oxygen sensor	x	x	
GPR-12-333-H	ppm Oxygen sensor for H ₂ and He gases	x	x	
XLT-12-333	ppm Oxygen sensor for gases with < 0.5 % CO ₂ presence	x	x	
GPR-11-60-4	% Oxygen sensor			x
XLT-11-24-4	% Oxygen sensor for gases with < 0.5 % CO ₂ presence			x
Memory Token				
LOGR-1003	Memory token	x	x	x
LOGR-1005	Memory token to USB adapter	x	x	x
Operational Spares				
PWRS-1003-KIT	9 V DC charger	x	x	x
A-4771	Battery assembly (for portable without pump)	x	x	x
A-4770	Battery assembly (for portable with pump)			
FITN-1003	Quick release plug - SS 1/8" NPT (qty 1)	x		
FLTR-1037	Coalescing filter element (for A-4442-1)		x	
CHEM-1008-2	H ₂ S scrubber media (1 liter)		x	x
Analyzer Hardware Spares				
CONN-1034	Analog output mini plug	x	x	x
A-2166	Sample pump		x	x
A-4665	Sample pump switch		x	x
	Carry case	x		x
	Carry case		x	
	Carry case (portable with H ₂ S scrubber)		x	
	Sensor cable	x	x	
A-4383-2	Sensor cable			x
B-2762-A-3-14	Sensor top housing assembly	x	x	
	Sensor top housing assembly			x
ORNG-1007	Sensor housing O-ring (Viton)	x	x	x
Accessories				
A-2734-6	Vent H ₂ S scrubber assembly		x	
A-4442-1	Sample coalescing filter assembly		x	x
	Panel with sample coalescing filter and vent H ₂ S scrubber		x	
	Panel with sample flow meter			x
	Panel with sample coalescing filter and flow meter			x
	Panel with sample coalescing filter, flow meter and vent H ₂ S scrubber			x



Appendix H - Rating Plate

Analytical Industries Inc.
2855 Metropolitan Place, Pomona, CA, 91767 USA
Portable Gas Analyzer: GPR-1000, GPR-1100, GPR-1200
GPR-1200 MS2, GPR-2000, GPR-7100

Serial No: [REDACTED] Year of Manufacture: [REDACTED]
CML 22ATEX2595X CML 22UKEX2594X IECEX CML 22.0090X

 II 1 G Ex ia IIC T4 Ga Class I Div 1 Groups ABCD, T4
Class I Zone 0 AEx ia IIC T4 Ga

Ambient Temperature Range: -20 to +50°C
Entity Parameters: Um = 9.45 VDC
0 - 1 V Analog Output Parameters:
Ui = Um = 28V, Ci= 12nF, Co= 71nF
Uo= 4.6V, Po= 2mW, Io= 2mA

 2776  2503
 LISTED Hazardous Location Safety E115647

 REFERENCE DWG. A-5592-EX FOR INSTALLATION REQUIREMENT
RÉFÉRENCE DWG. A-5592-EX POUR LES EXIGENCES D'INSTALLATION
WARNING - DO NOT CHARGE OR OPEN IN HAZARDOUS AREA
AVERTISSEMENT - NE PAS CHARGER NI OUVRIR DANS UN
EMPLACEMENT DANGEREUX

Appendix I - Quality, Recycling, and Warranty Information

Analytical Industries Inc. (Aii) is part of the Process Sensing Technologies (PST) Group. The PST Oxygen group of companies - Aii, Ntron and SST - comply with applicable national and international standards and directives.

Full information can be found on this website

<https://www.processsensing.com/en-us/resources/compliance/>

The compliance site contains information on the following directives:

- ATEX (equipment for explosive atmosphere, Europe)
- CE
- cMETus (electrical equipment for hazardous areas, North America)
- IECEx
- REACH (Registration, Evaluation, Authorization, and Restriction of Chemicals)
- Recycling policy
- RoHS (Restriction of Hazardous Substances in electrical and electronic equipment)
- UKCA
- WEEE (Waste Electrical and Electronic Equipment recycling).



ProcessSensing.com

Analytical Industries Incorporated (Aii) is part of the Process Sensing Technologies Group

©2024 Process Sensing Technologies
