



FREQUENCY RESPONSE ANALYZER

FRA5022

Instruction Manual

DA00016981-006

FREQUENCY RESPONSE ANALYZER

FRA5022

Instruction Manual

Registered Trademarks

National Instruments is a registered trademark of National Instruments Corporation in the United States.

Other company names and product names may be trademarks or registered trademarks of their respective companies.

———— Preface ————

Thank you very much for purchasing our “FRA5022 FREQUENCY RESPONSE ANALYZER”.

To ensure safe and proper use of this electric equipment, please read first “Safety Precautions” on the following pages.

● Caution Symbols Used in This Manual

The following caution symbols are used in this manual. Be sure to observe these caution symbols and their contents to ensure the safety of the user and avoid damage to the equipment.

WARNING

This symbol indicates information for the avoidance of a hazard such as electric shock that may endanger human life or cause injury during handling of the equipment.

CAUTION

This symbol indicates information for the avoidance of damage to the equipment during handling.

● This manual has the following chapter organization.

If using this equipment for the first time, start from Chapter 1.

1. OUTLINE

This chapter describes the overview, specificities, applications, functions and simple principle of operations of this product.

2. PREPARATIONS BEFORE USE

This chapter describes important preparation before installation and operation.

3. PANEL FEATURES AND BASIC OPERATIONS

This chapter describes the functions and simple operations available for each panel screen part.

Read while operation the device.

4. ADVANCED OPERATIONS

This chapter describes even further the device operation.

5. REMOTE CONTROL

This chapter describes remote control through GPIB or USB.

6. TROUBLESHOOTING

This chapter describes how to deal with error messages and troubles.

7. MAINTENANCE

This chapter describes storage, repacking, transportation as well as performance testing.

8. SPECIFICATIONS

This chapter describes the product's specifications (functions and performance).

———— Safety Precautions ————

To ensure safe use, be sure to observe the following warnings and cautions.

NF Corporation shall not be held liable for damages that arise from a failure to observe these warnings and cautions.

This product is a Class I product (with protective conductor terminal) that conforms to the JIS and IEC insulation standards.

- **Be sure to observe the contents of this instruction manual.**

This instruction manual contains information for the safe operation and use of this product.

Be sure to read this information first before using this product.

All the warnings in the instruction manual must be heeded to prevent hazards that may cause major accidents.

- **Be sure to ground the product.**

This product uses a line filter, which may cause electric shock if the product is not grounded.

This product is automatically grounded when its three-pole power supply plug is connected to a three-pole power outlet with a protective-ground contact.

- **Check the power supply voltage.**

This product operates on the power supply voltage indicated in “Grounding and Power Supply Connection” in this instruction manual.

Prior to connecting the power supply, check that the voltage of the power supply matches the rated power supply of the product.

- **In case of suspected anomaly**

If this product emits smoke, an abnormal smell, or abnormal noise, immediately power it off and stop using it.

If such an anomaly occurs, prevent anyone from using this product until it has been repaired, and immediately report the problem to NF Corporation or one of our representatives.

- **Do not use this product when gas is present.**

An explosion or other such hazard may result.

- **Do not remove the cover.**

This product contains high-voltage parts. Absolutely never remove its cover.

Even when the inside of this product needs to be inspected, do not touch the inside. All such inspections are to be performed by service technicians designated by NF Corporation.

- Do not modify this product.

Absolutely never modify this product, as this may cause new hazards and may disqualify this product from repair in case of failure.

- Safety-related symbols

The general definitions of the safety-related symbols used on this product and in the instruction manual are provided below.



Instruction Manual Reference Symbol

This symbol is displayed to alert the user to potential danger and refer him/her to the instruction manual.



Electric Shock Danger Symbol

This symbol indicates locations that present a risk of electric shock under specific conditions.



Warning Symbol

This symbol indicates information for the avoidance of a hazard such as electric shock that may endanger human life or cause injury during handling of the equipment.



Caution Symbol

This symbol indicates information for the avoidance of damage to the equipment during handling.

- Other symbols



This symbol indicates the "on" position of the power switch.



This symbol indicates the "off" position of the power switch.



Shows when connected to the case.



Shows when connected to the ground.

- Note on Waste Processing

To protect the environment, ensure that this device is disposed of by an appropriate industrial waste processor. Also note the following:

- This device includes lithium batteries.

Contents

	Page
1. OUTLINE	1-1
1.1 Features	1-2
1.2 Applications	1-2
1.3 List of Functions	1-3
1.4 Principle of Operation	1-5
2. PREPARATIONS BEFORE USE	2-1
2.1 Checking Before Use.....	2-2
2.2 Installation	2-3
2.2.1 General Precautions for Intallation	2-3
2.2.2 Installation Conditions	2-3
2.2.3 Rack Mounting	2-4
2.3 Grounding and Power Supply Connection	2-9
2.4 Simplified Operation Check	2-10
2.5 Calibration	2-11
3. PANEL FEATURES AND BASIC OPERATIONS.....	3-1
3.1 Panel Component Names and Functions	3-2
3.2 Display at Power “ON” and Initial Settings	3-5
3.2.1 Check before Power “ON”	3-5
3.2.2 Displays and Indications at Power “ON”	3-6
3.2.3 Initialization	3-6
3.3 I/O Terminals	3-9
3.3.1 Oscillator Output Terminal	3-9
3.3.2 Analyzer Input Terminal.....	3-10
3.3.3 Signal Terminal Isolation	3-11
3.4 I/O Connection	3-12
3.5 Basic Operations	3-13
3.5.1 Simplified Sweep Measurement	3-13
3.5.2 Setup Screen, Measurement Screen Switchover	3-14
3.5.3 Menu Screen Basic Operation	3-15
3.5.4 System Menu Screen	3-17
3.5.5 Sweep Menu Screen	3-20
3.5.6 Spot Menu Screen.....	3-27
3.5.7 Sweep Measurement	3-30
3.5.8 Sweep Measurement Screen	3-31
3.5.9 Spot Measurement	3-32
3.5.10 Spot Measurement Screen	3-33
3.5.11 Measured Values of Excessive Input	3-34

4.	ADVANCED OPERATIONS.....	4-1
4.1	Setup Screen.....	4-2
4.1.1	Setup Screen Display.....	4-2
4.1.2	Sweep Setup Screen	4-2
4.1.3	Spot Setup Screen	4-3
4.1.4	Oscillator Setup Screen	4-3
4.2	Settings Memory	4-4
4.2.1	Setting Memory Description	4-4
4.2.2	Setting Memory Setup Items	4-4
4.2.3	Setting Memory Operation	4-5
4.3	Result Evaluation	4-6
4.3.1	Evaluation Range Setting.....	4-6
4.3.2	Evaluation Display	4-6
4.4	Scan Measurement	4-7
4.4.1	Scan Related Setup Items.....	4-7
4.4.2	Scan Measurements Operation and Function	4-7
4.5	Servo System Measurement	4-9
4.6	Data Memory	4-12
4.7	Equalizer	4-13
4.8	Oscillator Output Terminal Change Rate Limit (SLOW)	4-14
5.	REMOTE CONTROL.....	5-1
5.1	Preparations Before Use	5-2
5.1.1	USB Preparations	5-2
5.1.2	GPIB Preparations	5-2
5.1.3	Remote Control Interface Selection.....	5-2
5.1.4	USB Device Identification.....	5-3
5.1.5	GPIB Address Setting	5-3
5.1.6	Necessary Precautions When Using GPIB.....	5-3
5.2	Remote State Display and Cancellation.....	5-3
5.3	Command List	5-4
5.4	Command Tree.....	5-9
5.5	Command Explanation	5-10
5.5.1	Summary of Terms	5-10
5.5.2	Command Detailed Explanations	5-11
5.6	Status System	5-33
5.6.1	Status System Overview	5-33
5.6.2	Status Byte.....	5-34
5.6.3	Standard Event Status.....	5-35
5.6.4	Operation Status	5-37
5.6.5	Overload Status	5-39
5.7	Programming Cautions.....	5-40

6. TROUBLESHOOTING	6-1
6.1 Error Messages	6-2
6.1.1 Errors at Power-On	6-2
6.1.2 Error During Panel Operation	6-3
6.1.3 Remote Control Errors	6-3
6.2 When Fault Symptoms are Observed	6-4
7. MAINTENANCE	7-1
7.1 Introduction	7-2
7.2 Daily Maintenance	7-2
7.3 Storage, Repacking, and Transportation	7-2
7.4 Checking Version Number	7-3
7.5 Checking Isolation	7-3
7.6 Checking Oscillator Output Wave Form	7-3
7.7 Performance Testing	7-3
7.7.1 Frequency Accuracy Test	7-4
7.7.2 Oscillator AC Amplitude Accuracy Test	7-4
7.7.3 Oscillator DC Bias Accuracy Test	7-4
7.7.4 Ratio Accuracy Test	7-5
7.7.5 IMRR Test	7-6
7.7.6 Dynamic Range Test	7-6
7.8 Calibration	7-7
8. SPECIFICATIONS	8-1
8.1 Oscillator	8-2
8.2 Analyzer Input	8-3
8.3 Analysis Processor	8-3
8.4 Measurement Processing	8-4
8.5 Display Part	8-5
8.6 Settings Memory	8-5
8.7 Remote Control Interface	8-5
8.8 General Information	8-6

Attached figures and tables

	Page
Figure 1-1 Block Diagram	1-5
Figure 2-1 Size and dimensions of the rack-mount (mm-rack)	2-5
Figure 2-2 Size and dimensions of the rack-mount (inch-rack)	2-6
Figure 2-3 Mounting rack-mount adapter (mm-rack)	2-7
Figure 2-4 Mounting rack-mount adapter (inch-rack)	2-7
Figure 2-5 Removal of feet	2-8
Figure 3-1 Front panel	3-3
Figure 3-2 Rear panel	3-4
Figure 3-3 Oscillator output terminal	3-9
Figure 3-4 Analyzer input terminal	3-10
Figure 3-5 Insulation voltages of input and output terminals	3-11
Figure 3-6 Connection with the system under test (SUT)	3-12
Figure 3-7 OSCILLATOR – CH1 internal connection	3-12
Figure 3-8 Setup screen, measurement screen switchover (description)	3-14
Figure 3-9 System menu screen	3-17
Figure 3-10 Sweep menu screen	3-20
Figure 3-11 Spot menu screen	3-27
Figure 3-12 Sweep measurement control keys	3-30
Figure 3-13 Sweep measurement screen	3-31
Figure 3-14 Spot measurement control key	3-32
Figure 3-15 Spot measurement screen	3-33
Figure 4-1 Setup key	4-2
Figure 4-2 Sweep setup screen (ex.)	4-2
Figure 4-3 Spot setup screen (ex.)	4-3
Figure 4-4 Oscillator setup screen (ex.)	4-3
Figure 4-5 Evaluation result display	4-6
Figure 4-6 Scan measurement	4-7
Figure 4-7 Connection for servo system measurement	4-9
Figure 4-8 Measurement voltage range magnification example	4-11
Figure 4-9 Connection with equalizer	4-13

Figure 5-1	Command tree	5-9
Figure 5-2	Status system	5-33
Figure 5-3	Standard event status structure	5-35
Figure 5-4	Operation status structure	5-37
Figure 5-5	Overload status structure.....	5-39
Figure 8-1	External dimensions	8-8
Table 2-1	Package Contents	2-2
Table 3-1	Setting items and initial values	3-7
Table 4-1	Setup items and screen handling	4-4
Table 5-1	FRA5022 subsystem command list	5-4
Table 5-2	Common command list.....	5-7
Table 5-3	Status byte register definitions	5-34
Table 5-4	Standard event status register contents	5-35
Table 5-5	Operation condition register contents	5-38
Table 5-6	Overload event register contents.....	5-39

1. OUTLINE

- 1.1 Features 1-2
- 1.2 Applications 1-2
- 1.3 List of Functions 1-3
- 1.4 Principle of Operation 1-5

1.1 Features

“FRA5022 Frequency Response Analyzer” allows you to obtain the frequency response characteristics (change of gain and phase vs frequency) of a system under test by supplying sine wave signals to the system under test and by analyzing the response signals.

- Oscillator frequency 0.1mHz to 100kHz
Covers the most suitable ranges to measure electrochemical impedance or analyze mechanical system servo.
- 2-channel simultaneous measurement
The 2-channel analyzer enables parallel signal reception, thus reducing the measurement time at lower frequencies compared to devices that receive signals sequentially via both channels.
- Input-Output isolation
The 2-channel analyzer input and the oscillator output are independently isolated from the case, thus facilitating the signal supply to the system under test when in servo analysis.
- Graph display
It is possible to display the frequency characteristics on a color liquid crystal display as Bode diagrams.
- Quick settings switchover
It is possible to switchover preset settings by pressing one button.
- Slim type
With a height of only 88mm (2U), the device fits conveniently in a system rack.
- Data display software
The supplied software allows you to easily export data to a personal computer, save data in CSV format, and display data as various graphs.

1.2 Applications

- Servo systems
Measurement of servo characteristics of systems such as CD/DVD players, etc.
- Electronic circuits
Measurement of frequency characteristics of systems such as filters, amplifiers, etc.
- Acoustics
Measurement of frequency characteristics of systems such as speakers, microphones, etc.
- Vibration analysis
Measurement of resonance characteristics
- Electrochemicals
Metallic corrosion studies, battery performance measurement (electrochemical impedance measurement)

1.3 List of Functions

Below is a tree listing of available functions.

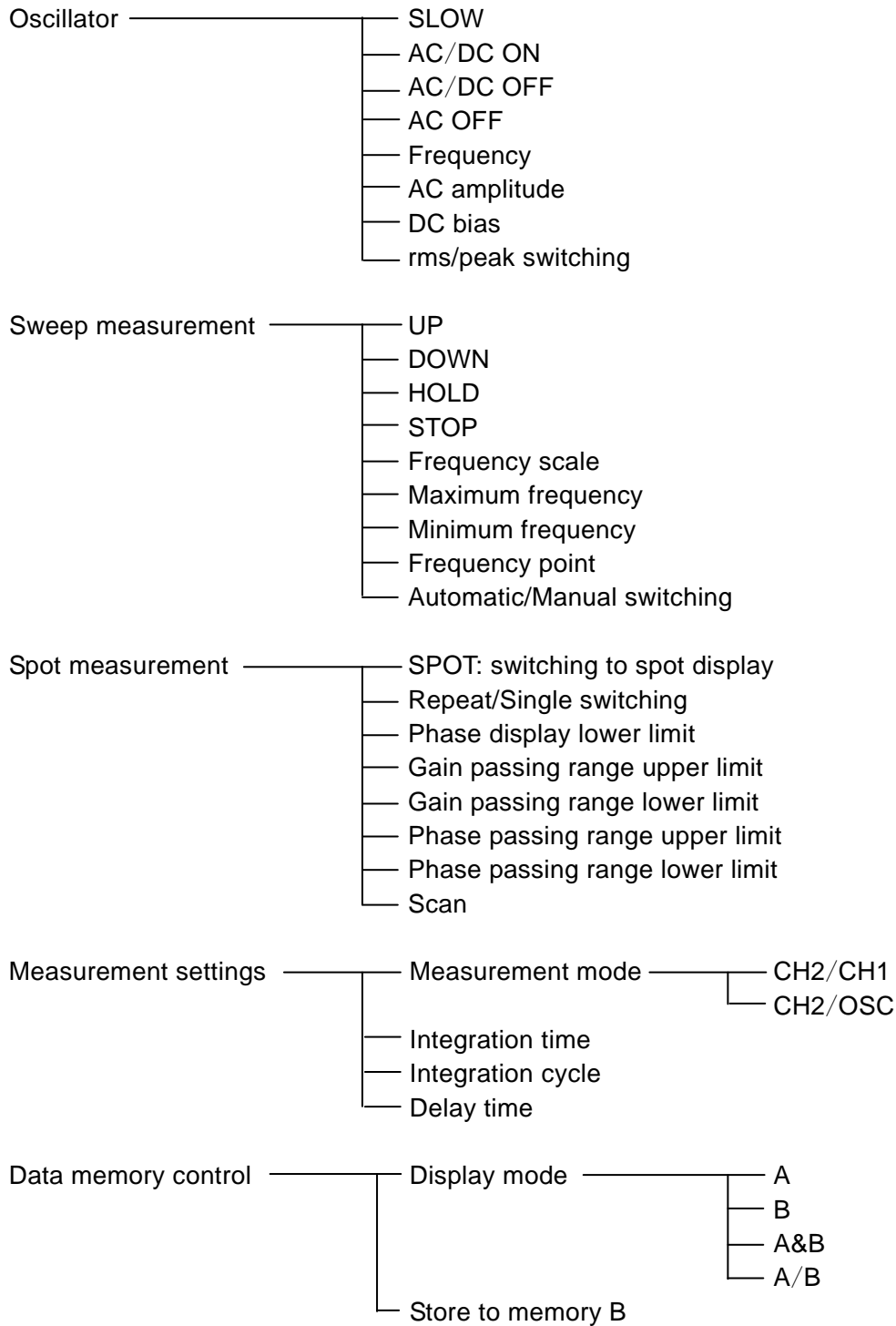

1.3 List of Functions

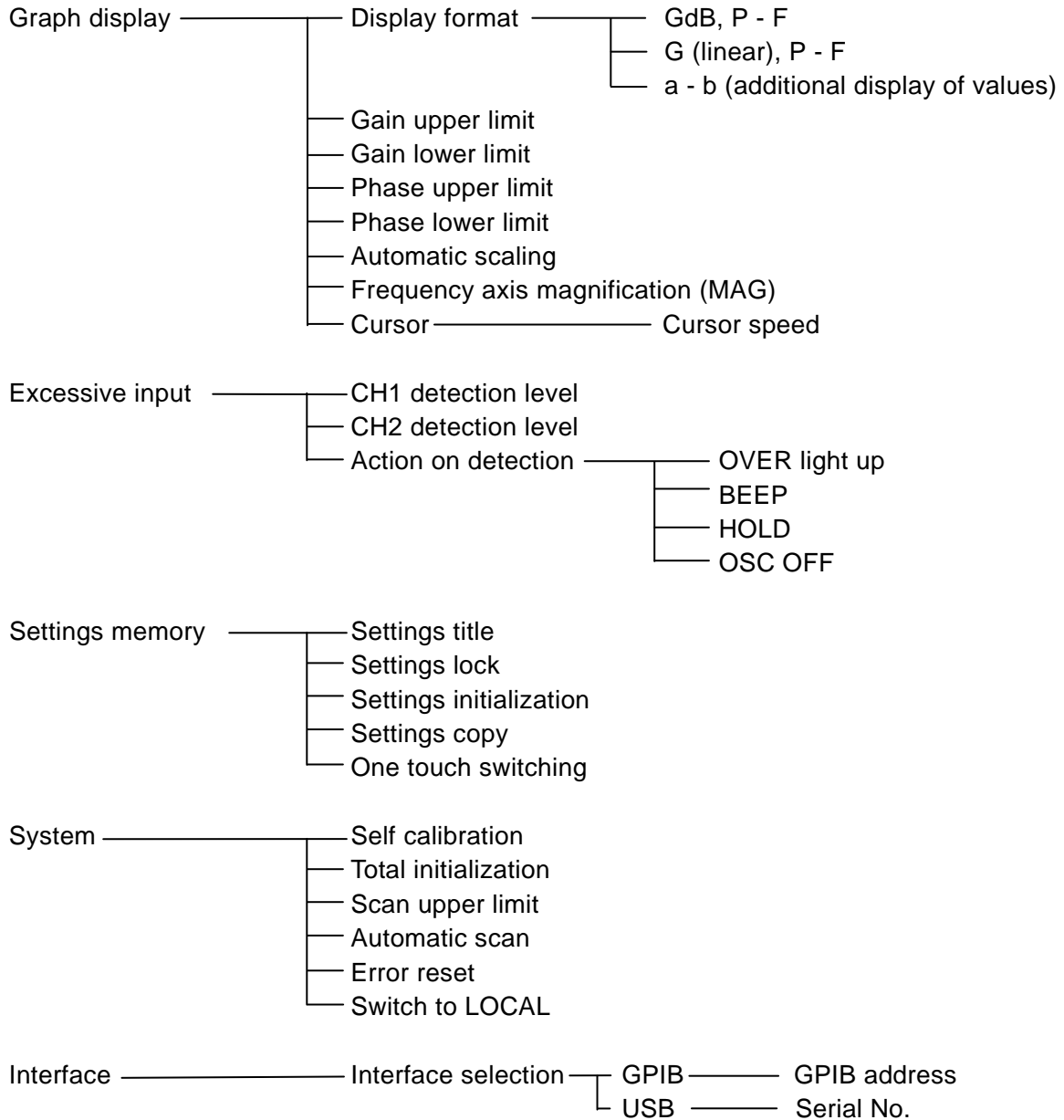

1.4 Principle of Operation

“FRA5022 Frequency Response Analyzer” obtains the vector ratio V_2/V_1 of the response signal V_1 and V_2 by supplying a sine wave test signal V_0 from its internal oscillator to the system under test, more specifically, the gain $G = |V_2/V_1|$ and phase differential $P = \angle V_2 - \angle V_1$ at a given frequency. Below are the block diagram and operation outline of FRA5022.

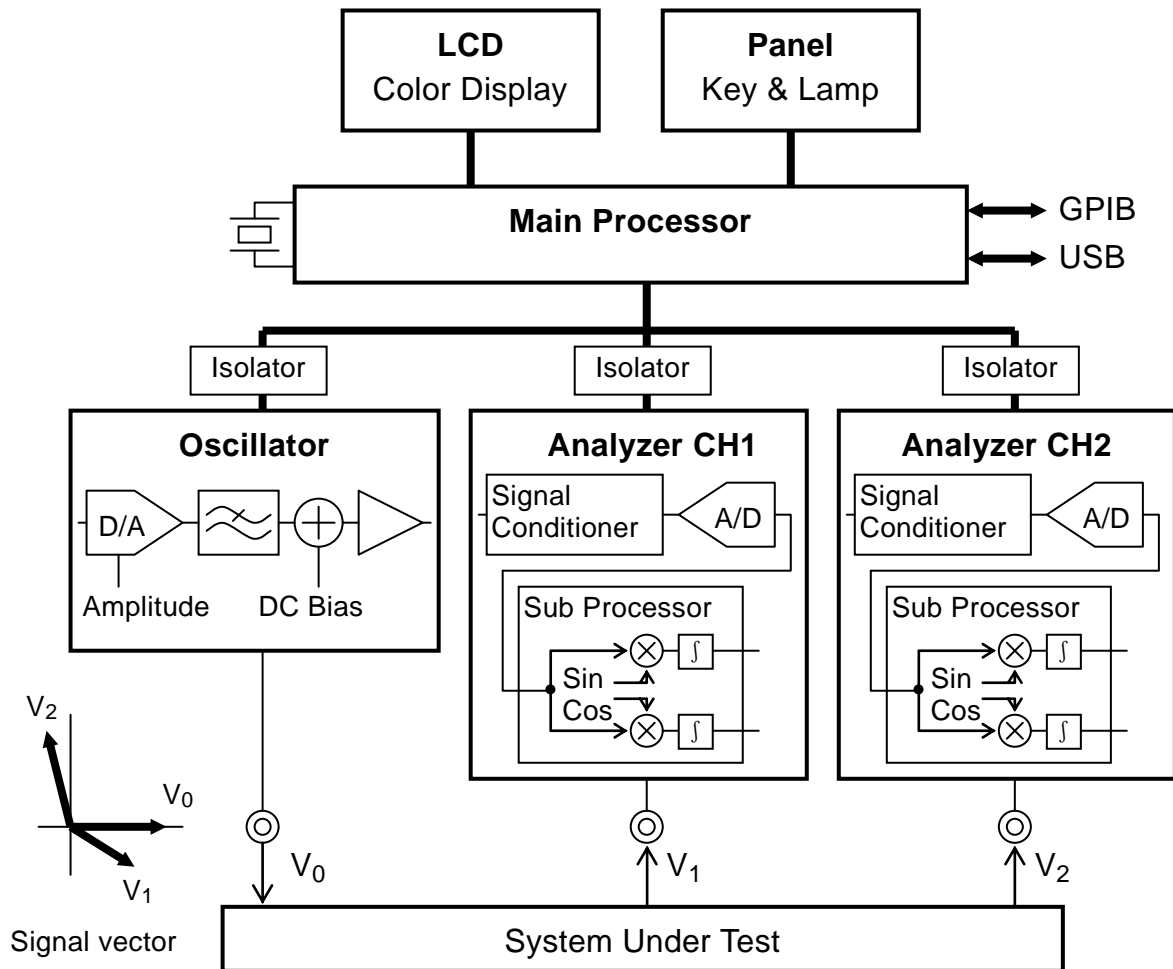

Figure 1-1 Block Diagram

- **Main Processor**

According to the user's operation, the main processor controls the oscillator and analyzer to calculate, output, and display the vector ratio of the signals obtained by the analyzer. By using the direct digital frequency synthesis method based on the reference quartz-crystal resonator, the main processor generates accurately pitched digital sine wave signals (Sin, Cos) to be used by the oscillator or analyzer.

- **Oscillator**

The FRA5022 oscillator converts digital sine signals to analog signals with D/A (Digital to Analog) converters and filters. It also adds DC bias before output.

- Analyzer

The analyzer performs, via the signal conditioner, appropriate adjustments such as level adjustment on the response signals from the system under test, and converts them to digital signals via the A/D (Analog to Digital) Converter. The subprocessor obtains the two orthogonal components of the signal (the signal vectors) by multiplication and integration of the response signal with orthogonal reference signals (Sin, Cos). This process allows to attenuate frequency components that do not match the signal frequency and thus render possible accurate measurements even with considerable noise.

2. PREPARATIONS BEFORE USE

2.1	Checking Before Use.....	2-2
2.2	Installation.....	2-3
2.2.1	General Precautions for Intallation.....	2-3
2.2.2	Installation Conditions.....	2-3
2.2.3	Rack Mounting	2-4
2.3	Grounding and Power Supply Connection	2-9
2.4	Simplified Operation Check.....	2-10
2.5	Calibration.....	2-11

2.1 Checking Before Use

■ Safety check

Before using FRA5022, make sure you read “Safety Precautions”, located at the beginning of this instruction manual and observe the required cautions.

Before turning the power on, read “2.3 Grounding and Power Supply Connection” and observe the necessary cautions.

■ Unpacking

Check that the device has not been damaged during transit.

Before installing the device, make sure that the contents listed below in “Table 2-1 Package Contents” are supplied in the carton.

Table 2-1 Package Contents

FRA5022 Body	1
Instruction Manual	1
Power Cord Set (3 Pole, 2m)	1
CD-ROM	1
Contents	• Data display software	
	• LabVIEW driver	
	• Sample program	

The data display software allows you to easily import the data from FRA5022 to a personal computer, save data in CSV format, display data as various graphs, and set main parameters.

Instructions for using the CD-ROM contents are not contained in this manual. For details on the contents, please refer to the instruction manual separately available in the CD-ROM. To view the CD-ROM contents, Adobe Acrobat Reader Ver.5 or later must be installed on your computer.

WARNING

This device contains high-voltage parts. Never remove the cover.

The internal parts of this device must only be serviced by an engineer who has a thorough understanding of risk prevention.

2.2 Installation

2.2.1 General Precautions for Intallation

CAUTION

Take the following precautions to prevent damage to FRA5022.

- FRA5022 is cooled by forced air-cooling. The air is inhaled from the bottom front panel and is exhaled from the center of the rear panel. Do not block the air inlet and outlet.
- When installed with the rear panel facing downward (in the upright position), FRA5022 sits unstably and easily topples down. Make sure that the device is installed in the horizontal position (with the bottom panel facing downward).

■ Handling of the panel and case

The front panel of FRA5022 is made of plastic. It can be damaged by sharp or hot tools. When the case/panel surface needs cleaning, wipe with a soft cloth. To remove persistent contamination, wipe with a soft cloth soaked with neutral detergent and wrung out. Do not use any organic solvents like thinner or benzene, or any chemical cleaning cloth, as they may cause the surface finish to deteriorate, tarnish, or come off.

2.2.2 Installation Conditions

Install FRA5022 in a location that fills the following temperature and humidity requirements.

Performance guarantee: +5 to +35°C, 5 to 85% RH (where absolute humidity is 1 to 25g/m³, non-condensing), Altitude:2000m or less

Operation: 0 to +40°C, 5 to 85% RH (where absolute humidity is 1 to 25g/m³, non-condensing), Altitude:2000m or less

Storage: -10 to +50°C, 5 to 95% RH (where absolute humidity is 1 to 29g/m³, non-condensing)

Do not install in locations such as:

- location with direct sunlight or with a nearby source of heat
- location with significant amounts of dust, salt, metallic powders
- location with significant amounts of corrosive gases, vapor, soot
- location exposed to excessive vibration
- location close to a strong magnetic or electromagnetic field source
- location close to a pulsing noise source

If measurement accuracy is important, perform warm-up for two hours or more and self calibration before measurement. It is recommended that self calibration be performed again when the ambient temperature has varied by five degrees or more or when the device has been operated continuously for 24 hours or more.

Make sure that enough distance is allowed between the power cable and the signal cable. Otherwise, measurements may vary greatly due to malfunction or noise.

2.2.3 Rack Mounting

FRA5022 can be mounted on a 19-inch IEC rack, an EIA specification rack or a JIS standard rack by the use of a rack-mount adapter (optional).

First, mount the rack-mount adapter on the device as shown in “Fig. 2-3 Mounting rack-mount adapter (mm-rack)” or “Fig. 2-4 Mounting rack-mount adapter (inch-rack)”, and then, mount the device on the rack.

 **CAUTION**

Take the following precautions when you mount the device on the rack:

- Support the FRA5022 by all means by installing some supports such as rails on the rack.
Otherwise, FRA5022 may fall, causing injury or damaging itself.
 - Make sure that the rack is sufficiently air-cooled by providing appropriate ventilation ports or cooling fans.
FRA5022 has air inlets at the bottom panel. When placing it on top of another device, allow a clearance of 20mm or more under FRA5022.
Otherwise, performance degradation or damage may be incurred due to the device temperature exceeding the specified level.
-

Remove the feet as shown in “Fig. 2-5 Removal of feet” when they interfere with the rail.

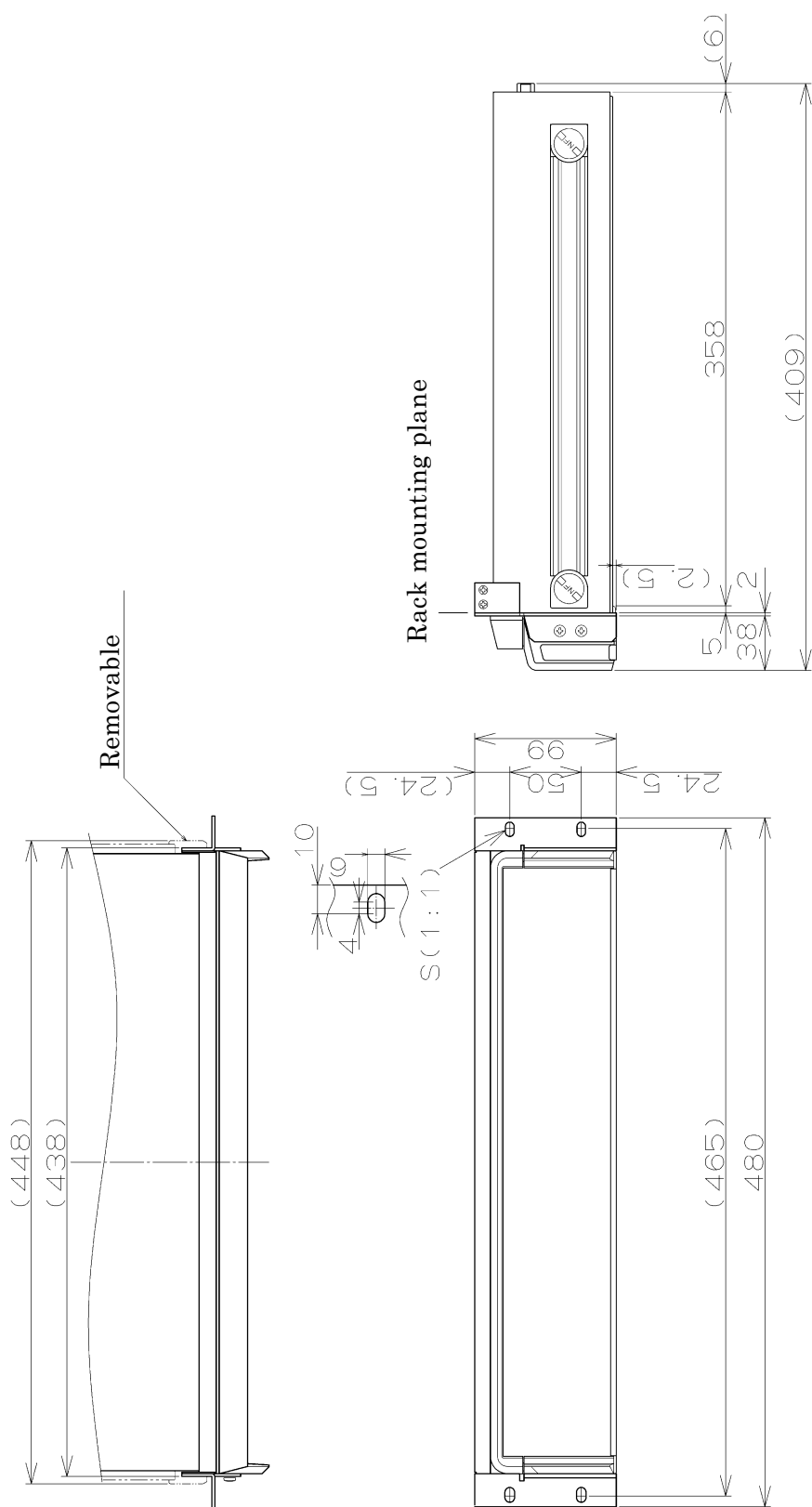

⚠ Caution

When mounting on the rack, do not use only the rack-mount adapter.
Make sure that the rack uses L metal fittings or shelves to hold the body.

Surface treatment
 Rack-mount adapter: Paint: Ultra Light Gray (Munsell 6. OPB9. 2/0. 1)

Figure 2-1 Size and dimensions of the rack-mount (mm-rack)

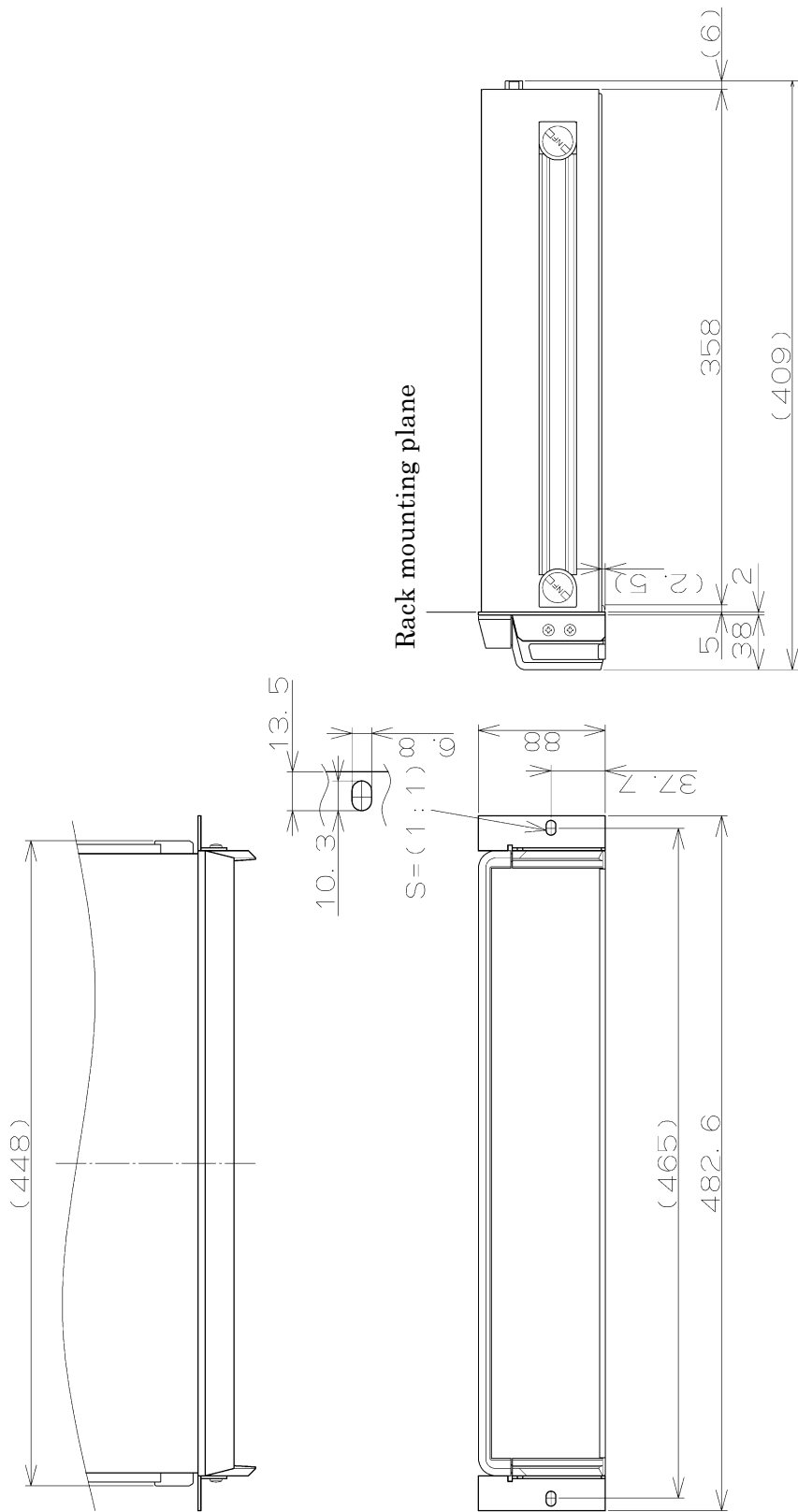

⚠ Caution

When mounting on the rack, do not use only the rack-mount adapter.
 Make sure that the rack uses L metal fittings or shelves to hold the body.

Surface treatment
 Rack-mount adapter: Paint: Ultra Light Gray (Munsell 6. OPB9. 2/0. 1)

Figure 2-2 Size and dimensions of the rack-mount (inch-rack)

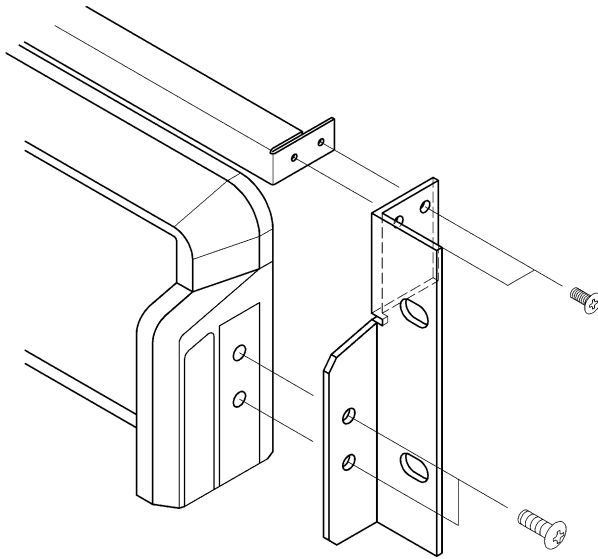

Rack-mount adapter mounting procedure

- Remove the screws on the sides of the front panel (2 each).
- Use the screws supplied with the rack-mount adapter.

Figure 2-3 Mounting rack-mount adapter (mm-rack)

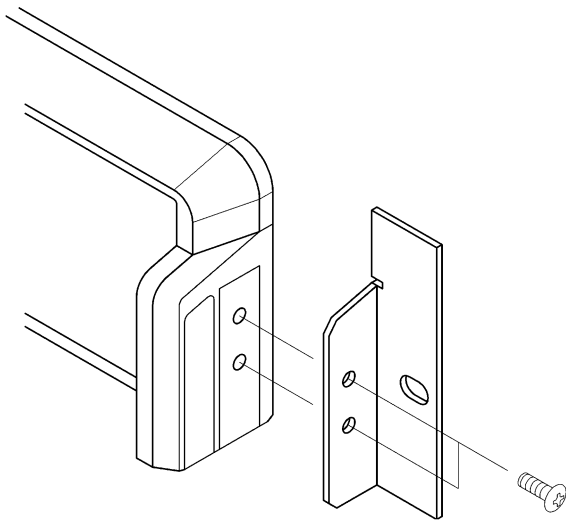

Figure 2-4 Mounting rack-mount adapter (inch-rack)

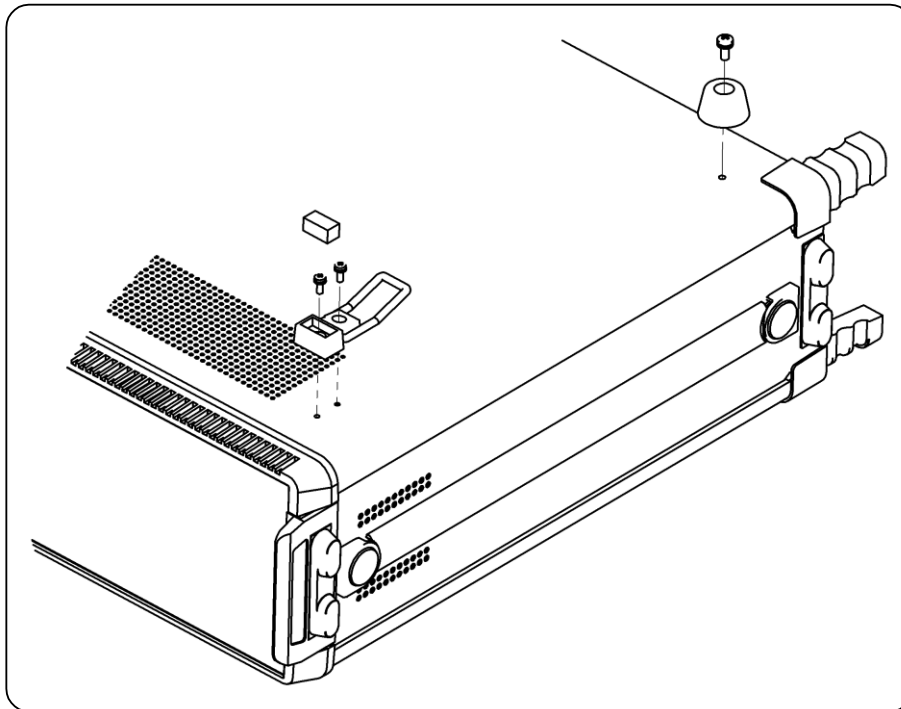

Figure 2-5 Removal of feet

2.3 Grounding and Power Supply Connection

■ Grounding

WARNING

Take the following precautions to avoid risk of electric shock.

Before connecting the device for measurement, make sure the protective grounding terminal is grounded.

The protective grounding terminal for FRA5022 is the grounding pin of the three-pole power cord. Make sure you insert the power cord's plug into a three-pole power outlet with a protective grounding contact.

■ Power Supply

CAUTION

To ensure that FRA5022 is not damaged, make sure to connect to the power outlet after checking that the power voltage is within the specified range for the FRA5022.

FRA5022 operates with the following commercial power supply.

Power voltage range: 100 to 230VAC \pm 10%, not exceeding 250VAC

Power frequency range: 50/60Hz \pm 2Hz

Maximum power consumption is 55VA.

Make sure that the power switch is set to OFF before connecting the power cord. After powering off the device, make sure to wait for at least three seconds before powering on again.

WARNING

This device contains high-voltage parts. Never remove the cover.

The power code set can be used for disconnecting the product from AC power line in case of emergency.

WARNING

Maintain enough space around the inlet, to be able to remove the connector of a power cord from the inlet. Use a power socket located at convenient place with adequate space around so that the plug can be removed from socket.

2.4 Simplified Operation Check

Before an important measurement or after not having used the device for a long period of time, it is recommended to check FRA5022 operation by following the procedure described here.

1. Plug the power cord into the AC outlet and turn the power switch on.
Wait until the initial messages disappear and the measurement screen is displayed.
2. Check the input/output isolation.
 - Use the resistance meter of a tester or multimeter, etc., to measure the resistance between the external conductor of each of OUTPUT OSCILLATOR, INPUT CH1, INPUT CH2, and the grounding terminal on the left of the front panel. Check that the resistance is $10\text{M}\Omega$ or more.
3. Initialize settings.
 - Use the MENU key to display the menu screen, select <SYSTEM> tab with the Left/Right cursor keys \triangleleft \triangleright .
 - Use the Up/Down cursor keys \triangleup \triangledown to select INITIALIZE all and press the key 1.
4. Connect FRA5022's OUTPUT OSCILLATOR terminal to an oscilloscope with a BNC-BNC cable, etc. Set the oscilloscope's parameters as below for example.
 - Input impedance: $1\text{M}\Omega$
 - Input sensitivity: $2\text{V}/\text{DIV}$
 - Sweep speed: $0.2\text{ms}/\text{DIV}$
 - Trigger level: 0V
5. Check the oscillator's output waveform.
 - Press the OSCILLATOR's SETUP key to display the oscillator's setup screen.
 - Use the Up/Down cursor keys to select OSC frequency and set the frequency to 2kHz for example.
 - Use the Up/Down cursor keys to select OSC ac amplitude and set the amplitude to 5V_{rms} for example.
 - Check that a sine wave of the specified amplitude is output and the ON lamp illuminates after pressing the ON AC/DC key.
6. Change the frequency or AC amplitude.
 - Change the frequency to any value and check that the set frequency signal is output.
 - Check that the AC amplitude is at the specified value after pressing the ON AC/DC key with the AC amplitude changed.
 - Lastly, change the amplitude to 1V_{rms} and press the ON AC/DC key.
7. Branch the output from OUT OSCILLATOR of FRA5022 to the INPUT CH1 and INPUT CH2 terminals.
Since the signal input/output is isolated from the case, connect the three signal ground conductors together.

8. Make the sweep measurement settings.

- Press the MEASUREMENT SETUP key to display the sweep setup screen.
- With the Up/Down cursor keys, select SWEEP freq. max and set the maximum value to 100kHz for example.
- With the Up/Down cursor keys, select SWEEP freq. min and set the minimum value to 10Hz for example.

9. Perform a sweep measurement and check that the general gain and phase are in the neighborhood of 0dB and 0deg respectively.

- Press the MEASUREMENT DOWN or UP key.
- After the sweep is complete, check the graph.

2.5 Calibration

Ensure that FRA5022 undergoes the test described in “7.7 Performance Testing” at least once a year, depending on the use environment and use frequency.

It is recommended to conduct a performance test before using it for an important measurement or test.

If the performance test does not produce satisfying results, NF Corporation will make the necessary adjustment or calibration to restore performance.

If calibration is necessary, contact NF Corporation or one of our representatives.

You will be liable for the costs of calibration.

3. PANEL FEATURES AND BASIC OPERATIONS

- 3.1 Panel Component Names and Functions3-2
- 3.2 Display at Power “ON” and Initial Settings3-5
 - 3.2.1 Check before Power “ON”3-5
 - 3.2.2 Displays and Indications at Power “ON”3-6
 - 3.2.3 Initialization.....3-6
- 3.3 I/O Terminals3-9
 - 3.3.1 Oscillator Output Terminal.....3-9
 - 3.3.2 Analyzer Input Terminal 3-10
 - 3.3.3 Signal Terminal Isolation..... 3-11
- 3.4 I/O Connection 3-12
- 3.5 Basic Operations 3-13
 - 3.5.1 Simplified Sweep Measurement 3-13
 - 3.5.2 Setup Screen, Measurement Screen Switchover
..... 3-14
 - 3.5.3 Menu Screen Basic Operation 3-15
 - 3.5.4 System Menu Screen..... 3-17
 - 3.5.5 Sweep Menu Screen..... 3-20
 - 3.5.6 Spot Menu Screen..... 3-27
 - 3.5.7 Sweep Measurement 3-30
 - 3.5.8 Sweep Measurement Screen 3-31
 - 3.5.9 Spot Measurement 3-32
 - 3.5.10 Spot Measurement Screen 3-33
 - 3.5.11 Measured Values of Excessive Input..... 3-34

3.1 Panel Component Names and Functions

This section describes the names and functions of the components on the front and rear panels of FRA5022.

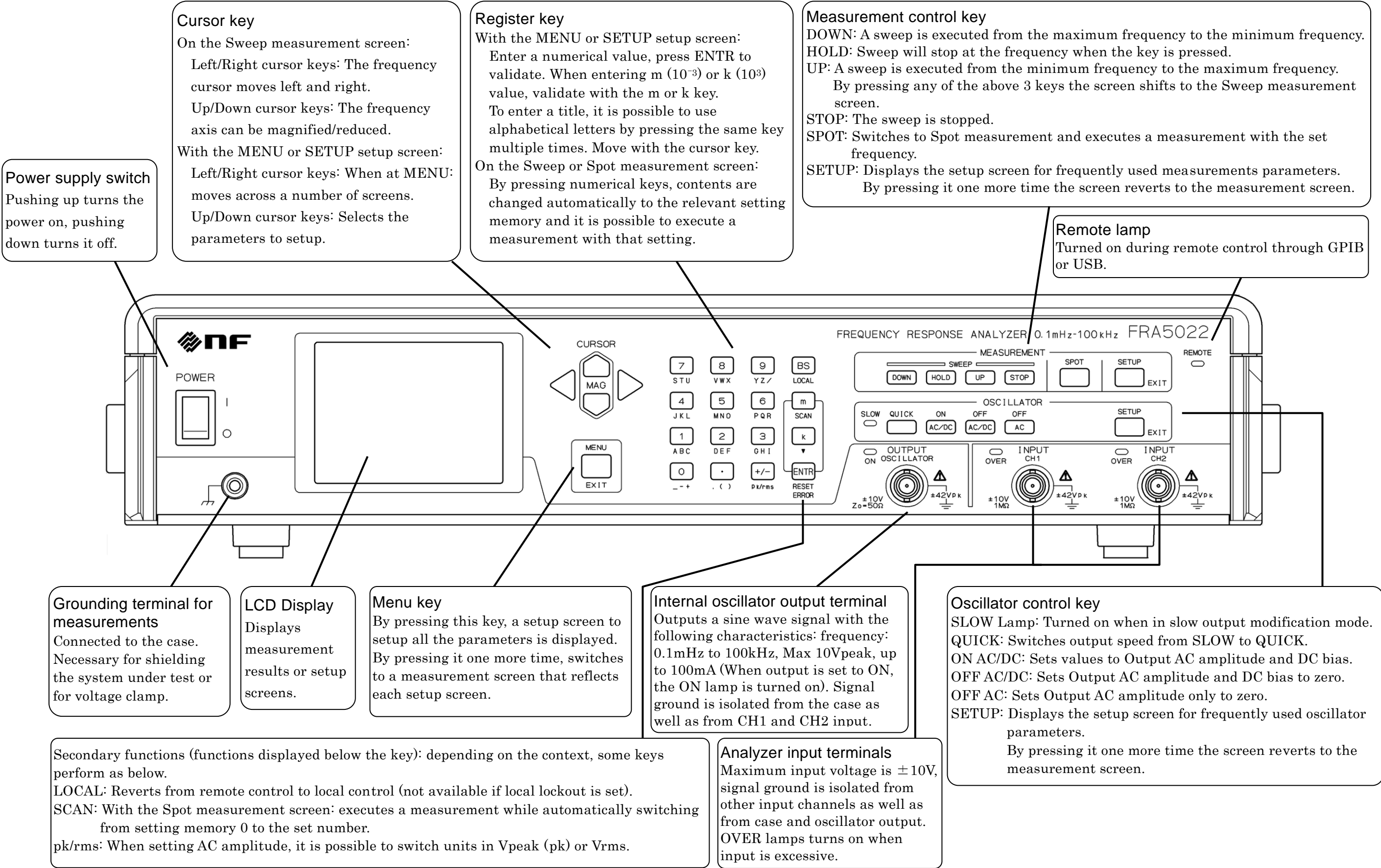

Figure 3-1 Front panel

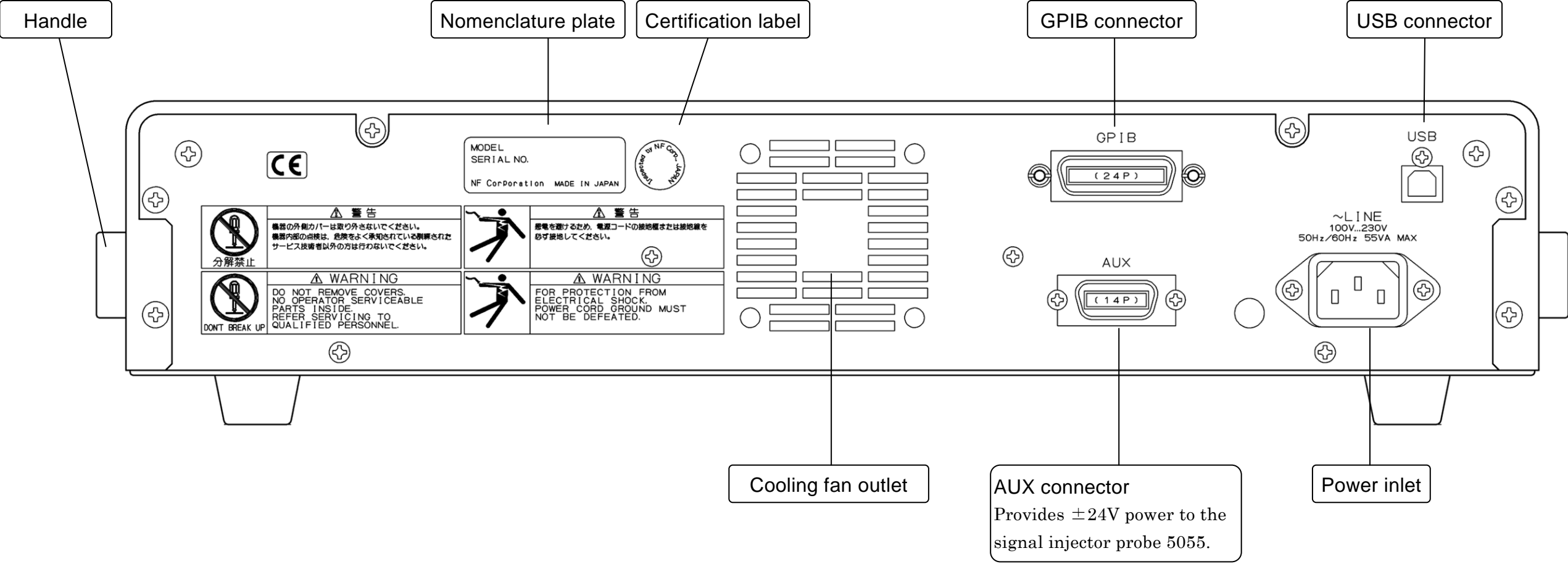

Figure 3-2 Rear panel

3.2 Display at Power “ON” and Initial Settings

3.2.1 Check before Power “ON”

FRA5022 operates with the following commercial power supplies.

Power voltage range: 100 to 230VAC \pm 10%, not exceeding 250VAC

Power frequency range: 50/60Hz \pm 2Hz

Maximum power consumption is 55VA.

CAUTION

Make sure to connect to the power socket after checking that the power voltage is within the specified range for the FRA5022. Otherwise, FRA5022 may be damaged.

WARNING

Take the following precautions to avoid accidents due to electric shock.

Before connecting the device for measurement, make sure the protective grounding terminal is grounded.

The protective grounding terminal for FRA5022 is as three-pole power cord grounding pin.

Make sure you insert the power cord's plug into a three-pole power socket with protective-ground contact.

Make sure that the power switch is set to OFF before connecting the power cord.

After turning the power off, make sure to wait for at least 3 seconds before turning it on again.

CAUTION

Wait at least 3 seconds between each power activation/deactivation.

Turning the power on and off in a very short span of time may cause the device to not work properly.

Turn the power on according to the following procedure.

- Make sure that the power switch is OFF (turned downward).
- Connect the power cord to the power inlet at the back of the device.
- Insert the power cord's plug to a three-pole power socket.
- By switching the power switch upward the FRA5022 is turned on.

When the device is turned on the start screen is displayed and self calibration starts. After self calibration has ended it is possible to use FRA5022 for measurements.

Display at launch  “3.2.2 Displays and Indications at Power “ON” ”

3.2.2 Displays and Indications at Power "ON"

Take necessary steps before instrument usage/operation according to "2. PREPARATIONS BEFORE USE".

Upon turning on the power switch, a sound is emitted and the device model name "FRA5022" as well as version number are displayed. All the lamps are lit for a short span of time. During this time, various checks, including memory self check are executed. In case of problem, the following error messages are displayed.

- ROM ERROR: Internal memory problem.
- SDRAM ERROR: Internal memory problem.
- BACKUP MEMORY ERROR: Battery backup contents are broken.
Either the backup battery is empty or there is a problem with the memory. Parameters are initialized and the device is launched.





Specifically  "6.1.1 Errors at Power-On"

Initialization contents  "3.2.3 Initialization"

If there are no battery backup errors, the settings in effect before the last power-off is recalled.

If the above self check is successful, the following check is signal related check and self calibration. When the progress bar has reached 100% and the self calibration has completed successfully a sound is emitted indicating that FRA5022 is ready for use.



To start the operation under the factory default settings, initialize all the settings by performing the steps below.

- Press the MENU key to display the menu screen.
- Use the Left/Right cursor keys   to select the <SYSTEM> tab.
- Use the Up/Down cursor keys   to select INITIALIZE all and press the key 1.

Initialization contents  "3.2.3 Initialization"

3.2.3 Initialization

FRA5022 is reset to the factory default settings in the following cases:

- At the time of shipment from factory
- When the settings stored in memory are found corrupted upon powering on
 "3.2.2 Displays and Indications at Power "ON" "
- After executing a total initialization
 "3.5.4 System Menu Screen"  Initialize all

Initialized items, initialized contents  "Table 3-1 Setting items and initial values"

3.2 Display at Power "ON" and Initial Settings

Table 3-1 Setting items and initial values (individual settings memory)

Setting items		Setting range	Initial values (factory values, lost values)	Total initial- ization
Settings memory SETTING	Memory selection memory	0 to 9	0	✓
	Title string TITLE	Max. 18 characters	Empty string	✓
	Settings change lock	Free/Lock	Free	✓
Oscillator OSC	Frequency frequency	0.10m to 100kHz	1kHz	✓
	AC amplitude ac amplitude	0.000 to 7.07V _{rms} (to 10.00V _{peak})	10mV _{rms}	✓
	DC bias dc bias	±10.00V	0.00V	✓
Measurement MEAS	Measurement mode mode	CH2/CH1 or CH2/OSC	CH2/CH1	✓
	Integration time integ. time	0.01 to 999.99s	0.02s	✓
	Integration cycle integ. cycle	1 to 999 cycles	1 cycle	✓
	Delay time delay time	0.00 to 999.99s	0.00s	✓
Sweep SWEEP	Frequency axis freq. axis	log/linear	Log	✓
	Maximum frequency freq. max	0.11m to 100.00kHz	100kHz	✓
	Minimum frequency freq. min	0.10m to 99.999kHz	1Hz	✓
	Frequency points points	3 to 1,000	100	✓
	Manual/Auto man / auto	Manual/Auto	Auto	✓
Measurement display DISP	Data memory display mode data memory	A, B, A&B, A/B	A (most recent measured value)	✓
	Coordinate axis coordinates F: Frequency G: Gain P: Phase	• G dB, P - F • G , P - F • a - b	G dB, P - F	✓
	Graph Y-axis scaling scale	Manual/Auto	Auto	✓
	Graph gain display max gain max	-179.9 to 180.0 dB	60.0dB	✓
	Graph gain display min gain min	-180.0 to 179.9 dB	-60.0dB	✓
	Graph phase display max phase max	-359.9 to 360.0 deg	180.0deg	✓
	Graph phase display min phase min	-360.0 to 359.9 deg	-180.0deg	✓
	Spot phase display minimum value spot phase min	-360.0 to 0.0 deg	-180.0deg	✓

✓: set to initial values Blank: no change

Table 3-1 Setting items and initial values Cont. (individual settings memory)

Setting items		Setting range	Initial values (factory values, lost values)	Total initialization
Excessive input detection OVER	Detection level CH1 level ch1	0.01 to 19.99Vrms	19.99Vrms	✓
	Detection level CH2 level ch2	0.01 to 19.99Vrms	19.99Vrms	✓
	Response response	<ul style="list-style-type: none"> • OVER lamp lighting • Alarm sound generated • Sweep stop • Oscillator OFF 	OVER lamp lighting	✓
Spot measurement SPOT	Repeat measurement REPEAT	ON/OFF	ON	✓
	Result evaluation gain max GO/NG G max	± 199.99dB	199.99dB	✓
	Result evaluation gain min GO/NG G min	± 199.99dB	-199.99dB	✓
	Result evaluation phase max GO/NG P max	± 360.00deg	360.00deg	✓
	Result evaluation phase min GO/NG P min	± 360.00deg	-360.00deg	✓

✓: set to initial values Blank: no change

Table 3-1 Setting items and initial values Cont. (system settings, others)

Setting items		Setting range	Initial values (factory values, lost values)	Total initialization
Scan measurement SCAN	Scan memory number upper limit limit	0: Scan lock, 1 to 9	0: Scan lock	✓
	Automatic scan man/auto	Manual/Auto	Auto	✓
Oscillator OSC	Slow on/off slow on/off	Quick only / Slow enable	Quick only	✓
Interface INTERFACE	Connection method connect	GPIB / USB	GPIB	
	GPIB address address	0 to 30	2	
(measurement screen)	---	Sweep/Spot	Sweep	
Output on/off		on/off	off	

✓: set to initial values Blank: no change

3.3 I/O Terminals

3.3.1 Oscillator Output Terminal

The main specifications for the oscillator's output OSCILLATOR are as bellow.

Maximum output voltage: $\pm 10\text{V}/\text{open}$, $\pm 5\text{V}/50\ \Omega$

Output impedance: $50\ \Omega$, unbalanced

The voltage added to the load is changed according to the load impedance.

Maximum output current: $\pm 100\text{mA}$

With short-circuited output and the DC bias 0V , the output amperage reaches this maximum allowable limit when the AC amplitude is approximately 3.5V_{rms} (5V_{peak}).

⚠ CAUTION

Do not connect to a load exceeding the maximum output current. Do not add an external signal.

Otherwise, FRA5022 may be damaged.

A warning message may be displayed when the maximum output current is exceeded.

■ Output voltage limits

If the AC amplitude and the DC bias settings produce a composed voltage that exceeds $\pm 10\text{V}/\text{open}$, the output may be clipped.

■ Output when the power is turned off

When the device is powered off or waiting to be ready for measurement after power-on, the output terminal is isolated from the internal oscillator, with a termination resistance of $50\ \Omega$. When the device is powered on and then off, the output terminal becomes open for a short duration.

⚠ CAUTION

Even when the power is off, do not apply an external signal.

Applying a voltage exceeding 5V can damage FRA5022.

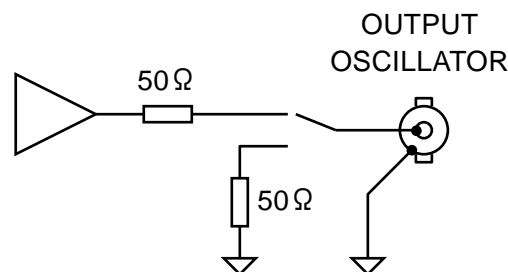

Figure 3-3 Oscillator output terminal

When the oscillator is turned OFF by using the AC/DC key, the output voltage becomes 0V , but the output terminal is not isolated from the internal parts.

3.3.2 Analyzer Input Terminal

The main specifications for the analyzer input CH1 and CH2 are as bellow.

Input impedance: $1\text{M}\Omega$, parallel 60pF

Measurement voltage range: $\pm 10\text{V}$

Non-destructive maximum input voltage: $\pm 24\text{V}$

⚠ CAUTION

Do not apply a signal that exceeds the non-destructive maximum input voltage.

Otherwise, FRA5022 may be damaged.

■ Input when the power is turned off

When the device is powered off or waiting to be ready for measurement after power-on, the input terminals as well as the external conductor (ground) are isolated from the internal parts.

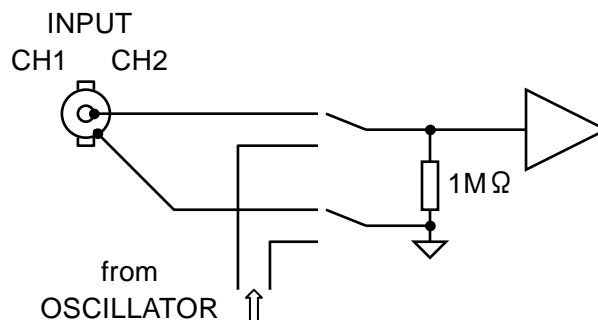

Figure 3-4 Analyzer input terminal

■ CH1 input for CH2/OSC

When the measurement mode is set to CH2/OSC, CH1 input terminal is open. The analyzer CH1 input is connected internally to the oscillator output.

■ Operation on excessive input

When the input signal exceeds the measurement range ($\pm 10\text{V}$) or when the excessive input voltage specified for each channel is exceeded, the OVER lamp for the relevant channel illuminates. Depending on the settings for operations with excessive input, a sound may be generated. The OVER lamp or warning sound will not be automatically cleared even after the excessive input is removed. Clear by pressing the ENTR/RESET ERROR key.

3.3.3 Signal Terminal Isolation

Each of the oscillator output OSCILLATOR, analyzer input CH1 and CH2 are electrically insulated from the case.

The insulation voltage between all parts is 42Vpk.

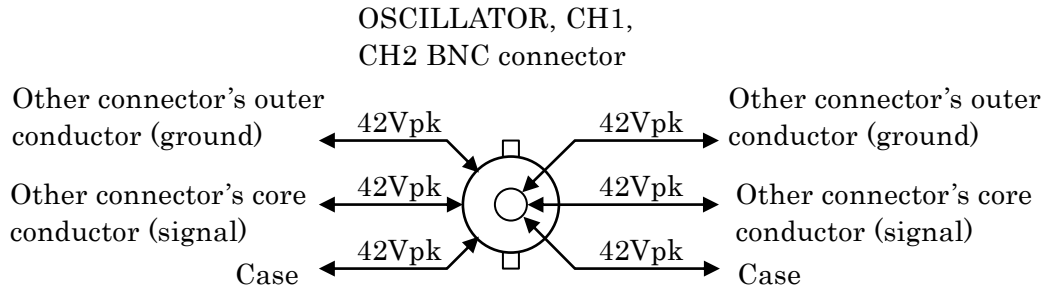

Figure 3-5 Insulation voltages of input and output terminals

⚠ CAUTION

Do not connect the isolated parts to a signal that exceeds 42Vpk.
Otherwise, FRA5022 may be damaged.

3.4 I/O Connection

The connection of the system under test to FRA5022 is described in the following figure. The oscillator output OSCILLATOR sends a signal to the system under test and the transfer function between A – B (gain or phase frequency response) is measured.

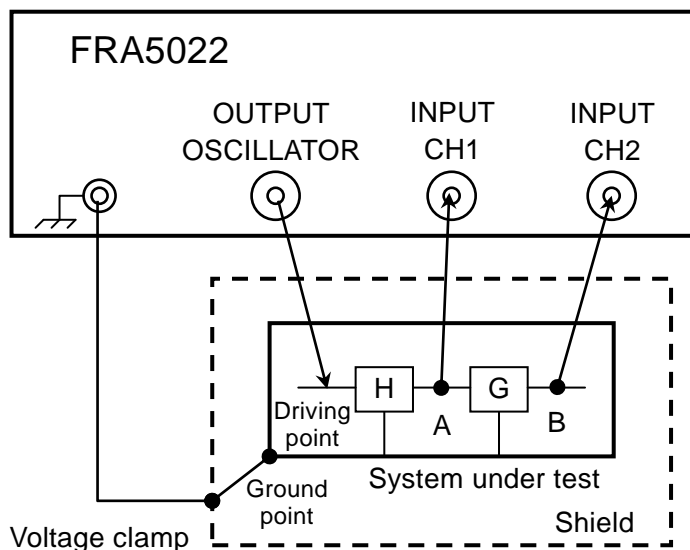

Figure 3-6 Connection with the system under test (SUT)

It is possible to use the FRA5022 front panel grounding terminal as the SUT's ground or shield.

■ CH1 Input internal connection

When the oscillator output OSCILLATOR is used with the analyzer input CH1 it is possible to make the connection inside FRA5022. When connecting internally, set the measurement mode to CH2/OSC. Especially when the frequency is high, the error compared to CH1 connector connection can become important.

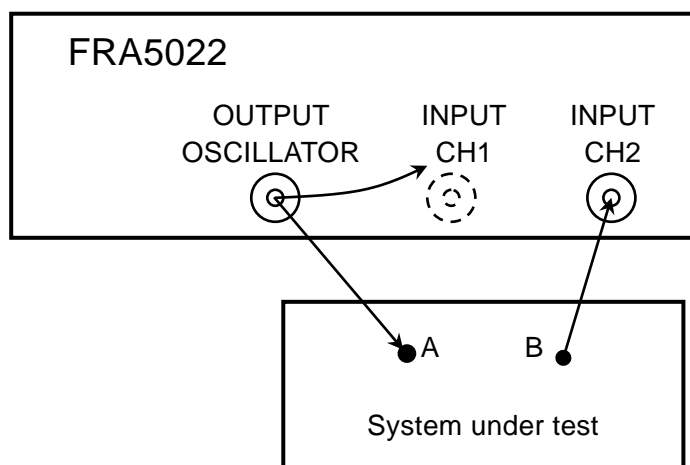

Figure 3-7 OSCILLATOR – CH1 internal connection

3.5 Basic Operations

3.5.1 Simplified Sweep Measurement

This section describes simplified operations when first using FRA5022.

It describes as frequency sweep and a measurement of a system's frequency response.

Proceed according to the following procedure.

- 1) Initialization: executed to simplify understanding of the following steps.
- 2) Setting the measurement conditions
- 3) Sweep measurement
- 4) Measured values reading

■ Initialization

- Press the MENU/EXIT key to display the menu screen.
- Use the Left/Right cursor keys $\triangleleft \triangleright$ to move to the system menu $\langle \text{SYSTEM} \rangle$ screen.
- Use the Up/Down cursor keys $\triangleup \triangledown$ to select INITIALIZE all.
- Press the key 1 to initialize.

■ Setting the measurement conditions

- Use the Left/Right cursor keys $\triangleleft \triangleright$ to move to the sweep setup $\langle \text{SWEEP} \rangle$ screen.
- Set the values as below for example.

AC Amplitude	OSC ac amplitude	1.00Vrms	Set the value with the ENTR key
DC bias	OSC dc bias	0.00V	Set the value with the ENTR key
Integration time	MEAS integ. time	0.10s	Set the value with the ENTR key
Integration cycle	MEAS integ. cycle	1c	Set the value with the ENTR key
Frequency max	SWEEP freq. max	100.00kHz	Set the value with the k key
Frequency min	SWEEP freq. min	10.000Hz	Set the value with the ENTR key
Automatic scaling	DISP scale	Auto	

After measurement, the vertical scale is automatically selected.

For the possible settings range, check the comments in the lower side of the screen.

- Press the ON AC/DC OSCILLATOR key to turn the oscillator's output on.
The oscillator's output voltage will not change by only modifying the setup value. It is changed by this procedure.

■ Sweep measurement

- Press the Measurement DOWN or UP key.
The screen changes to Sweep measurement screen and the measured gain and phase are displayed as a graph (Bode diagram).

■ Measured values reading

- Use the Left/Right cursor keys $\triangleleft \triangleright$ to move the graph's frequency data cursor (vertical line), the measured value at the position of the cursor is displayed as a numerical value.

3.5.2 Setup Screen, Measurement Screen Switchover

It is possible to switch from the measurement condition setup screen to the measured data display measurement screen mostly by using the MENU/EXIT key. When the measurement screen is displayed, pressing the MENU/EXIT key will display the menu screen. Pressing the MENU/EXIT key once again will return to the measurement screen. It is possible to return to the measurement screen by pressing either of the DOWN, HOLD, UP, STOP, SPOT key.

When only a partial change of the conditions is desired, press the SETUP key and a convenient setup screen including frequently used parameters for sweep measurements, spot measurements, oscillator settings is displayed.

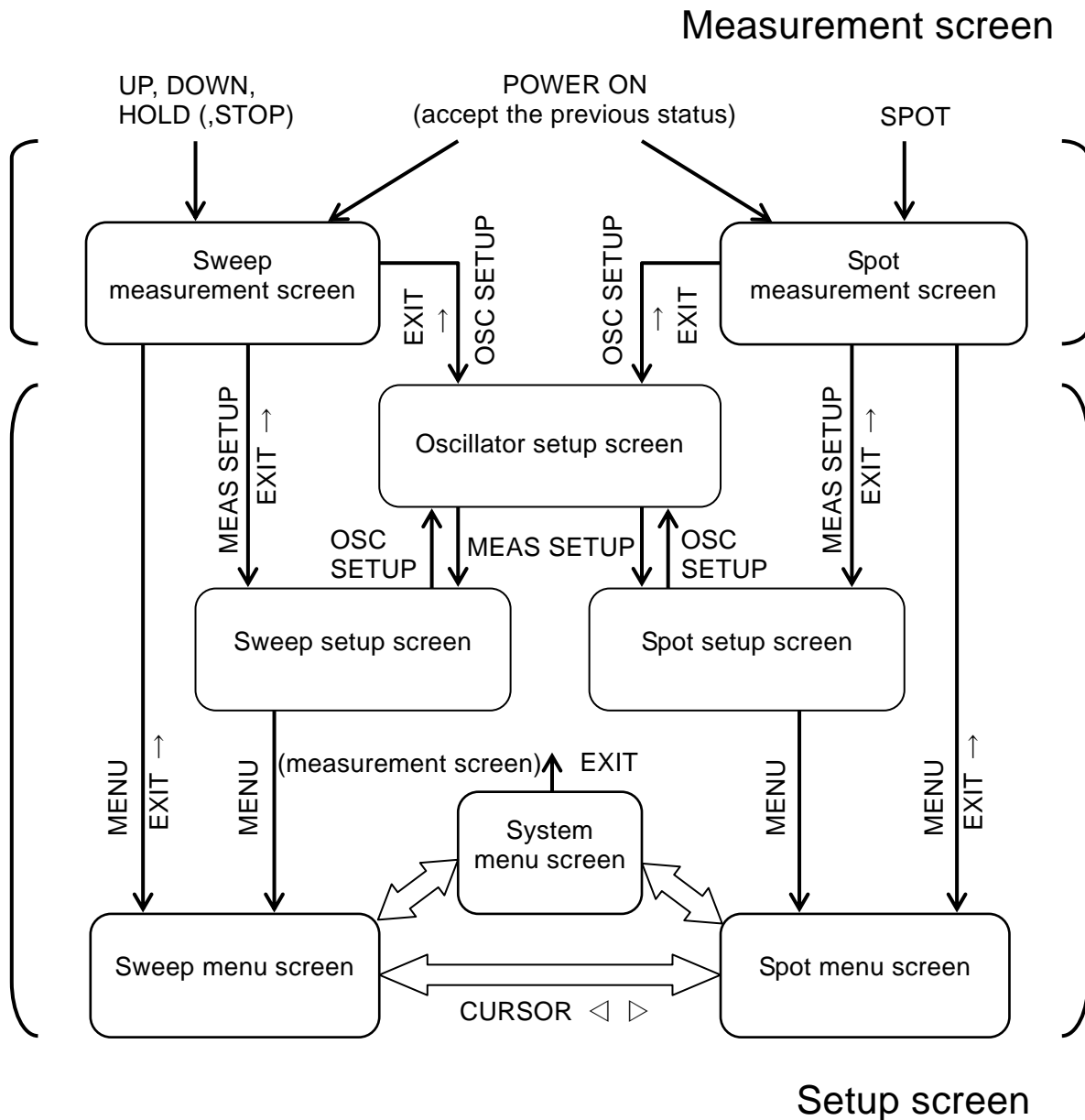

Figure 3-8 Setup screen, measurement screen switchover (description)

3.5.3 Menu Screen Basic Operation

Basic operation of the settings is as follows.

- Menu screen display: MENU/EXIT key
- Menu screen switchover: Left/Right cursor keys (CURSOR ◀ ▶)
- Setting items selection: Up/Down cursor keys (CURSOR ▲ ▼)
- Value setup or operation instruction: Register key
- Return to the measurement screen: MENU/EXIT key

■ Menu screen switchover

The menu screen has three sub-menus that are switchable with the Left/Right cursor key.

- System menu screen: Settings related to remote control and FRA5022 in general
- Sweep menu screen: Settings related to sweep measurements
- Spot menu screen: Settings related to spot measurements

■ Setting items selection

Lines for each setup item can be selected by using the Up/Down cursor key.

When the setup items are too numerous to be displayed on one page it is possible to scroll the screen.

The lower part of the screen displays settable ranges and other comments.

■ Setting values

To set values such as frequency, use the numerical keys (0 to 9), the decimal key (.), the inverted key (+/-), and the ENTR key to validate a setting. To enter m (10^{-3}) or k (10^3) use the m or k key in place of the ENTR key.

Before using ENTR to confirm a value, it is possible to use the BS/LOCAL key (backspace key) to delete the previously entered character. If the cursor keys are used to move to a different item before the value is validated, it will be deleted.

To set AC amplitude, use the +/- pk/rms keys to switch the unit between V_{peak} and V_{rms} .

■ Parameter selection

For setup items that give a choice of parameters, it is possible to select the parameter with the numerical keys. The correspondence between the numbers and the parameters are indicated in the lower section of the screen. Use the indications to proceed with the selection. It is not necessary to use the ENTR key.

■ Operation instructions

It is possible to use a numerical key corresponding to an instruction to execute operation instructions only once, such as writing measurement data to data memory B. It is not necessary to use the ENTR key. The operation is executed by simply pressing the numerical key.

■ Title entry

It is possible to enter alphabetical or numerical characters in the TITLE setup item. Entry can be done with the numerical key, the decimal (comma) and the register key. Pressing a key a number of times will display a list of corresponding alphabetical or other characters below that key. For example, pressing the key 7 a number of times will produce the following display.

7 → S → T → U → 7 ...

To enter multiple characters, use the right cursor key ▷ to move the input location to the right.

Confirm the entry by pressing the ENTR key.

■ Error messages handling

When the set values exceed the possible range, an error message is displayed.

The message can be dismissed by pressing the ENTR/RESET ERROR key. Dismiss the message after checking its contents.

3.5.4 System Menu Screen

Items that are common to FRA5022 as a whole, or remote control items can be setup in the System menu screen.

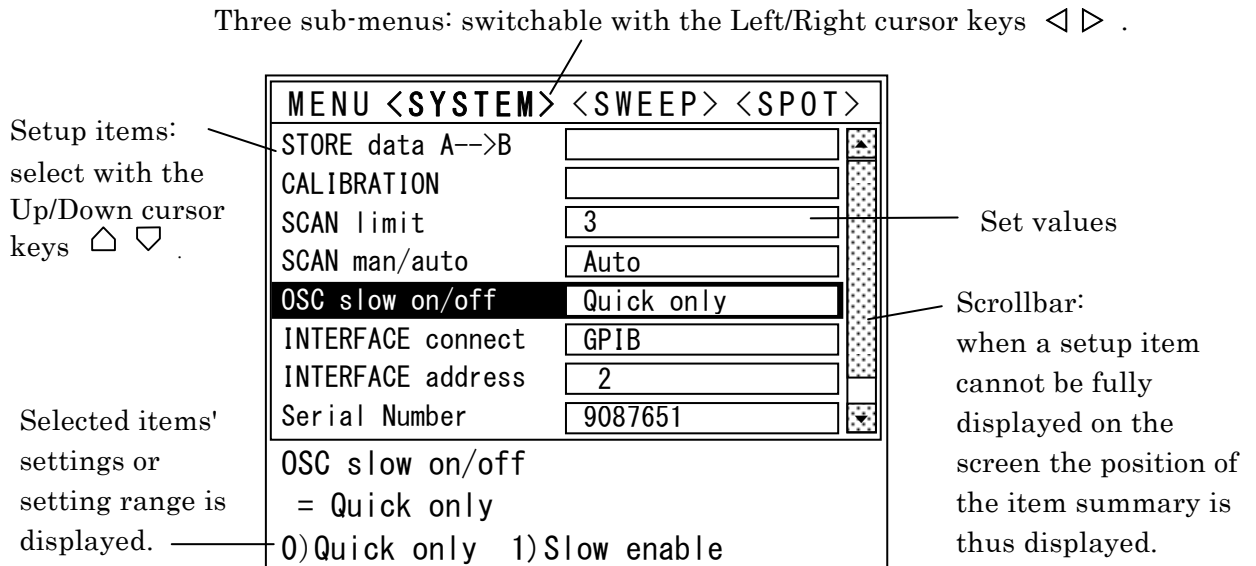

Figure 3-9 System menu screen

■ Measurement data recording STORE data A-->B

Value range: 1) Execute

Description: By pressing the 1 key, the most recent measurement data (data memory A contents) is copied to data memory B.

■ Self calibration CALIBRATION

Value range: 1) Execute, 9) Extend

Description: By pressing the 1 key, a self calibration is executed.

Self calibration takes about 50 seconds. It is not possible to stop it while it is being executed.

9) Extend is reserved for the function extensions. Currently is the same function as 1) Execute.

■ Scan upper limit

SCAN limit

Value range: 0) Disable, 1 - 9

Description: 0) Disable: Locks scan.

1 - 9: Scan range is from setting memory 0 to the number set.

Initial values: 0) Disable

■ Automatic scan

SCAN auto/man

Value range: 0) Auto 1) Manual

Description: Auto: Automatic scan

When in scan measurement, the measurements are made as spot by automatically switching the setting memory in order, the result evaluation for the multiple settings is made in batch.

Manual: Manual scan

When in scan measurement, the measurement is made once by switching to the next setting memory and the result evaluation is made.

Initial values: 0) Auto

Scan measurement details  "4.4 Scan Measurement"**■ Oscillator output terminal change rate limit**

OSC slow on/off

Value range: 0) Quick only 1) Slow enable

Description: It is possible to limit the output terminal change rate not to damage the system under test by the abrupt change of the output.

0) Quick only: Instruction for turning the output on/off immediately turns the output on/off.

The SLOW lamp is off and the QUICK key is disabled.

1) Slow enable: When the change rate limit setting is enabled, the SLOW lamp illuminates and the AC amplitude and DC bias of the output changes linearly within a duration of up to 10 seconds.

Pressing the QUICK key is allowed only once, to linearly change the output.

Initial values: 0) Quick only

-
- Remote control interface selection INTERFACE connect
- Value range: 0) GPIB 1) USB
- Description: Sets to either GPIB or USB. It is not possible to use both at the same time.
- Initial values: 0) GPIB The initialization will not modify the setting, it will stay as originally.
-
- GPIB address INTERFACE address
- Value range: 0 - 30
- Description: Sets the FRA5022 address for the GPIB system.
Set a value that differs from the values assigned to other devices connected to the same bus.
- Initial values: 2 The initialization will not modify the GPIB address, it will stay as originally.
-
- Serial Number Serial Number
- Description: Serial number for the FRA5022 model. This value cannot be modified.
The value is necessary to identify the device when a connection to FRA5022 is made through USB.
-
- Initialize all INITIALIZE all
- Value range: 1) Execute
- Description: By pressing the 1 key, all the settings related to measurement are initialized.
Contents of data memory A and B are not erased.
Details... ☞ "Table 3-1 Setting items and initial values"

The following setup item of the system menu screen is independent from the 10 setting memories and kept by the backup battery even when the power is off it will not be erased.

- Scan upper limit: SCAN limit
- Automatic scan: SCAN man/auto
- Oscillator output terminal change rate limit: OSC slow on/off
- Remote control interface selection: INTERFACE connect
- GPIB address: INTERFACE address

3.5.5 Sweep Menu Screen

The Sweep Menu Screen allows you to set the items for sweep measurement.

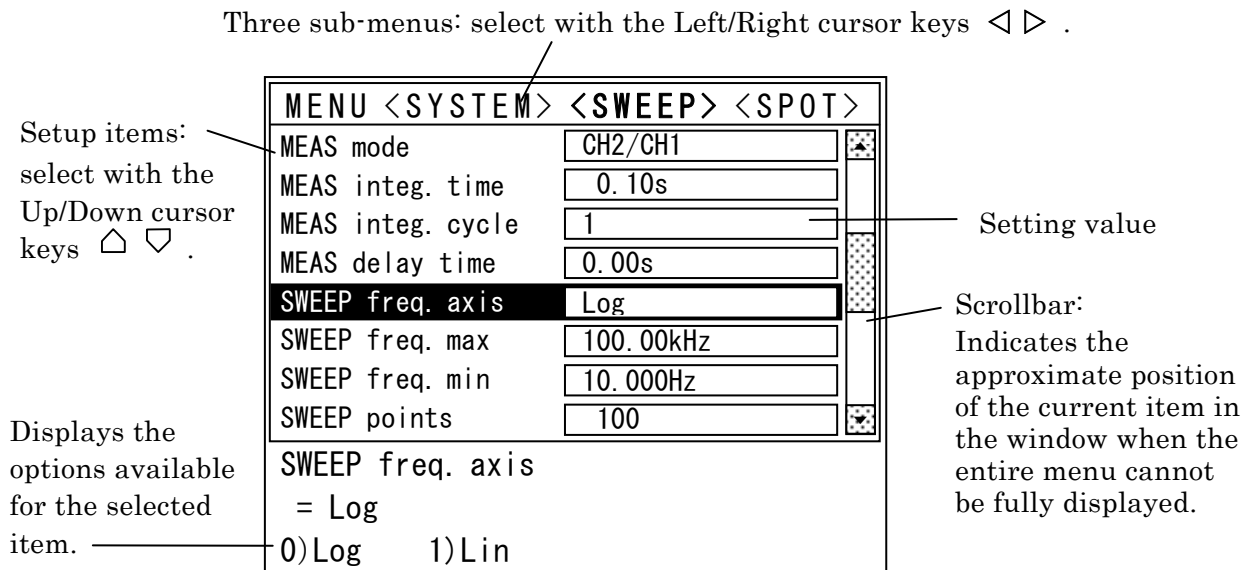

Figure 3-10 Sweep menu screen

■ Setting memory selection SETTING memory

Value range: 0 - 9

Description: FRA5022 can use 10 individual settings memories.

The settings in the sweep screen are not limited to changing the settings of the actual measurements but can also be registered in the specified setting memories.

Initial values: 0

■ Setting memory title TITLE

Value range: Maximum 18 characters using the following:

- Alphabet (upper case A to Z)
 - Numerical characters (0 - 9) and decimal point
 - Other characters $_$ (white space), -, +, (,), /
- (the underscore above denotes white space.)

Description: Title for each setting memory.

With each press of the numeric key, the number is switched to alphabets and symbols.

Pressing the right cursor key \triangleright moves the input position to the right.

Initial values: Empty string

-
- **Measurement mode** **MEAS mode**
- Value range: 0) CH2/CH1 1) CH2/OSC
- Description: Selects the reference signal for frequency response (transfer function) measures.
- With CH2/CH1, the change up to CH2 is measured with reference to CH1 input.
- When CH2/OSC, the change up to CH2 is measured with reference to the oscillator output. CH1 input terminal is then separated from the internal and is open.
- Initial values: 0) CH2/CH1
-
- **Integration time** **MEAS integ. time**
- Value range: 0.01 - 999.99 s
- Description: Specifies the integration time for the signal. The longer, the less susceptible to noise is the measurement.
- The actual integration time is the longer of the shortest signal cycle duration equal or greater than this value or the integration cycle(s) separately specified.
- Initial values: 0.02s
-
- **Integration cycle** **MEAS integ. cycle**
- Value range: 1 - 999 cycles
- Description: Specifies the integration time for the signal as the signal cycle count.
- Initial values: 1 cycle
-
- **Delay time** **MEAS delay time**
- Value range: 0.00 - 999.99 s
- Description: Delay time from the point when the frequency, amplitude, or DC bias is modified to the point when the actual measurement using the modified values starts. When the system under test exhibits some latency due to high order filters or the like, accurate measurement cannot be obtained unless sufficient time is allowed before the response is stabilized.
- Initial values: 0.00 s

- **Frequency scale** **SWEEP freq. axis**
 - Value range: 0) Log 1) Lin
 - Description: When in frequency sweep it selects either the geometrical interval (Log) or the arithmetic interval (Lin). This will modify the frequency axis display of the graph.
 - Initial values: 0) Log

- **Frequency max** **SWEEP freq. max**
 - Value range: 0.11m - 100.00kHz
 - Description: Maximum frequency when in frequency sweep.
 - Initial values: 100kHz

- **Frequency min** **SWEEP freq. min**
 - Value range: 0.10m - 99.999kHz
 - Description: Minimum frequency when in frequency sweep.
 - Initial values: 1Hz

- **Frequency point** **SWEEP points**
 - Value range: 3 - 1000 points
 - Description: The number of frequency (measurement) points to be used when in frequency sweep.
Measurement is performed between the maximum and minimum frequencies at the specified number of frequency points spaced equally apart on the linear axis (Lin) or logarithmic axis (Log).
The measurement data can be stored in the memory for up to 1000 frequency points. Pressing UP/DOWN keys many times during sweep measurement may use up the measurement data memory space and aborts the sweep measurement before it reaches the maximum or minimum frequency.
 - Initial values: 100

- **Automatic sweep** **SWEEP man/auto**
 - Value range: 0) Auto 1) Manual
 - Description: Auto: Measures at all the specified frequency points by changing the frequency automatically.
Manual: Measures at one point with each press of one of the DOWN/HOLD/UP keys.
 - Initial values: 0) Auto

-
- **Data memory display** DISP data memory
- Value range: 0) A 1) B 2) A&B 3) A/B
- Description: A: Displays the contents of data memory A (most recent measured data).
- B: Displays the contents of data memory B.
- A&B: Displays the contents of data memory A and B.
- A/B: Displays the vector ratio (magnitude ratio, phase difference).
- Initial values: 0) A
-
- **Graph axis (measured value display format)** DISP coordinates
- Value range: 0) GdB, P-F 1) G, P-F 2) a-b
- Description: GdB, P-F: Displays the values Gain dB, Phase deg, Frequency Hz.
- G,P-F: Displays the values Gain (linear), Phase deg, Frequency Hz.
- a-b: Rectangular coordinate display.
- Displays the gain as a complex number expression $a+jb$, where a is the real part and b is the imaginary part.
- Graphs are always displayed as a Bode diagram (GdB, P-F), regardless of the above settings.
- Initial values: 0) GdB, P-F

-
- **Graph Y-axis automatic scaling** **DISP scale**
Value range: 0) Auto 1) Manual
Description: Auto: After measurement, the vertical scale is automatically adjusted.
 Manual: The display range for the Y-axis can be set manually.
Initial values: 0) Auto

 - **Graph gain maximum value** **DISP gain max**
Value range: -179.9 to 180.0dB
Description: Graph (Bode diagram) maximum value for the gain axis.
Initial values: 60.0dB

 - **Graph gain minimum value** **DISP gain min**
Value range: -180.0 to 179.9dB
Description: Graph (Bode diagram) minimum value for the gain axis.
Initial values: -60.0dB

 - **Graph phase maximum value** **DISP phase max**
Value range: -359.9 to 360.0deg
Description: Graph (Bode diagram) maximum value for the phase axis.
Initial values: 180.0deg

 - **Graph phase minimum value** **DISP phase min**
Value range: -360.0 to 359.9deg
Description: Graph (Bode diagram) minimum value for the phase axis.
Initial values: -180.0deg

The phase value is displayed within a range from the set graph phase minimum value to that value plus 359.99 deg.

- **CH1 Excessive input detection level** **OVER level ch1**
 Value range: 0.01 to 19.99Vrms
 Description: The excessive input detection level for CH1. Determined with the rms value of the fundamental wave.
 Initial values: 19.99Vrms
- **CH2 Excessive input detection level** **OVER level ch2**
 Value range: 0.01 to 19.99Vrms
 Description: The excessive input detection level for CH2. Determined with the rms value of the fundamental wave.
 Initial values: 19.99Vrms
- **Operation with excessive input** **OVER response**
 Value range: 0) Lamp 1) Beep 2) Hold 3) Off
 Description: Set the response for detection of excessive input.
 Lamp: Turns on the OVER lamp for the channel with excessive input.
 Beep: An alarm sound is generated upon the illumination of the lamp.
 Hold : Besides for the 2 above items. a sweep would also be aborted and set to HOLD.
 During a scan measurement, the scan would be stopped and would remain at the last setting.
 Off: Besides for the 3 above items, the AC and DC output of the oscillator would be turned off.
 Initial values: 0) Lamp
- **Setting memory protection** **SETTING lock**
 Value range: 0) Free 1) Lock
 Description: To prevent mistaken settings it is possible to lock the settings.
 Free: It is always possible to change the settings.
 Lock: Setting is locked.
 Initial values: 0) Free
- **Setting memory individual initialization** **SETTING clear**
 Item name: 1) Initialize
 Description: Initializes only the setting memory currently in use.
 Other setting memories will not be initialized.
- **Setting memory contents copy** **SETTING copy to**
 Value range: 0 to 9: Setting memory number
 Description: Copies the contents of the currently displayed setting memory to another setting memory.
 If the displayed memory is locked, the copy target will become free.
 If the target memory is locked the copy is not possible.

3.5.6 Spot Menu Screen

The Spot Menu Screen allows you to set items for spot measurement.

Three sub-menus: select with the Left/Right cursor keys ◀ ▶ .

Setup items: select with the Up/Down cursor keys ▲ ▼ .

Displays the options available for the selected item.

MENU <SYSTEM> <SWEEP> <SPOT>	
REPEAT on/off	0n
MEAS mode	CH2/CH1
MEAS integ. time	0.50s
MEAS integ. cycle	2c
MEAS delay time	0.00s
DISP data memory	A
DISP coordinates	GdB, P-F
DISP phase min	-180deg
MEAS delay time = 0.05	
0.00 to 999.99 s	

Setting value

Scrollbar: Indicates the approximate position of the current item in the window when the entire menu cannot be fully displayed.

Figure 3-11 Spot menu screen

☐ The items marked with a solid white square mark are shared with the sweep measurement screen. For the details, refer to the descriptions of the sweep measurement screen.

- ☐ Setting memory selection: SETTING memory
- ☐ Setting memory title: TITLE
- ☐ Oscillator frequency: OSC frequency
- ☐ Oscillator AC amplitude: OSC ac amplitude
- ☐ Oscillator DC bias: OSC dc bias

-
- Repeat measurement REPEAT on/off
 - Value range: 0) On 1) Off
 - Description: Specifies whether the measurement is automatically in sequences or if it is executed once only.
 - On: Automatic repeat measurement
 - Off: Manual single measurement. With each press of the SPOT key, one measurement is performed.
 - Initial values: 0) On

 - Measurement mode: MEAS mode
 - Integration time: MEAS integ. time
 - Integration cycle: MEAS integ. cycle
 - Delay time: MEAS delay time

 - It is possible to set a delay time even for a single spot measurement.

 - Data memory display: DISP data memory
 - Under spot measurement, even if A&B are set only the latest measured value A is displayed.

 - Graph axis (measured values display format): DISP coordinates
 - Under spot measurement, the value display is fixed to “Frequency, Gain dB, Phase”.
 - Even with “G, P-F” or “a, b” selected, Gain (linear) or a, b is not displayed. It is possible to read the values from the remote control interface.

 - Phase minimum value DISP spot phase min
 - Value range: -360.0 to 0.0 deg
 - Description: Sets the phase minimum value. The phase range is “minimum value” to “minimum value+359.99 deg”.

 - CH1 Excessive input detection level: OVER level ch1
 - CH2 Excessive input detection level: OVER level ch2
 - Operation with excessive input: OVER response

- Result evaluation Gain maximum value SPOT GO/NG G max
 Value range: -199.99 to 199.99
 Description: The result evaluation gain maximum value.
 Initial values: 0 When maximum value \leq minimum value, no evaluation is made and the result is positive.

- Result evaluation Gain minimum value SPOT GO/NG G min
 Value range: -199.99 to 199.99
 Description: The result evaluation gain minimum value.
 Initial values: 0 When maximum value \leq minimum value, no evaluation is made and the result is positive.

- Result evaluation Phase maximum value SPOT GO/NG P max
 Value range: -360.00 to 360.00
 Description: The result evaluation phase maximum value.
 Initial values: 0 When maximum value \leq minimum value, no evaluation is made and the result is positive.

- Result evaluation Phase minimum value SPOT GO/NG P min
 Value range: -360.00 to 360.00
 Description: The result evaluation phase minimum value.
 Initial values: 0 When maximum value \leq minimum value, no evaluation is made and the result is positive.

Result evaluation details  "4.3 Result Evaluation"

- Setting memory protection: SETTING lock
- Setting memory individual initialization: SETTING clear
- Setting memory contents copy: SETTING copy to

3.5.7 Sweep Measurement

Sweep measurement measures gain and phase by sweeping the frequency. The settings for measurements or display are made under the Sweep menu screen.

☞ “3.5.5 Sweep Menu Screen”

The measurements results are displayed on the sweep measurement screen as Bode diagrams.

Sweep measurements are made by operating the four keys located on the MEASUREMENT SWEEP part of the front panel. The operation related to each key is described below. The UP key is disabled while the sweep is in the UP mode.

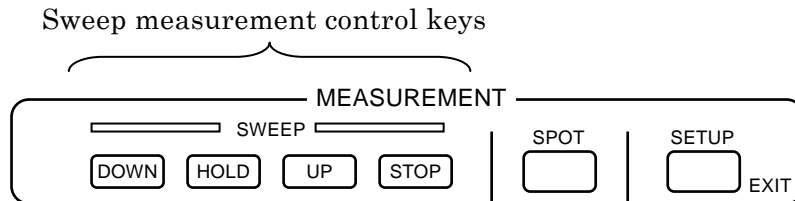

Figure 3-12 Sweep measurement control keys

DOWN	<p>Performs a sweep from the maximum frequency to the minimum frequency when the operation is in the STOP mode.</p> <p>When HOLD or UP is active, a sweep is executed from the frequency f at that point to the minimum frequency.</p> <p>If $f \leq$ minimum frequency or $f >$ maximum frequency the sweep is executed from the maximum frequency.</p> <p>A manual sweep performs a measurement only once toward the next frequency point.</p>
UP	<p>Performs a sweep from the minimum frequency to the maximum frequency when the operation is in the STOP mode.</p> <p>When HOLD or DOWN is active, a sweep is executed from the frequency f at that point to the maximum frequency. If $f \geq$ maximum frequency or $f <$ minimum frequency the sweep is executed from the minimum frequency.</p> <p>A manual sweep performs a measurement only once toward the next frequency point.</p>
HOLD	<p>Stops frequency change. Fixes the frequency to the current point and performs a measurement.</p> <p>Even if $f <$ minimum frequency or $f >$ maximum frequency, a measurement is performed at f.</p> <p>In an automatic sweep, the measurement is repeated for that frequency.</p> <p>In a manual sweep, the measurement is made only once at that frequency.</p>
STOP	<p>Stops sweep measurement. Retains the last frequency used.</p> <p>When the total number of measured data has reached the maximum data memory volume of 1000 point it becomes impossible to perform further measurements and the sweep is stopped.</p>

■ Operation upon pressing of MENU key or SETUP key

Pressing the MENU key or SETUP key displays the setup screen. While the setup screen is displayed, sweep measurement is paused and no measurement is performed. After the settings are changed, the previous measurement data will be displayed until a new measurement is started.

3.5.8 Sweep Measurement Screen

The Sweep measurement screen displays the measured gain (dB) and phase (deg) as a Bode diagram.

The settings for measurements or display are made under the Sweep menu screen.

☞ “3.5.5 Sweep Menu Screen”

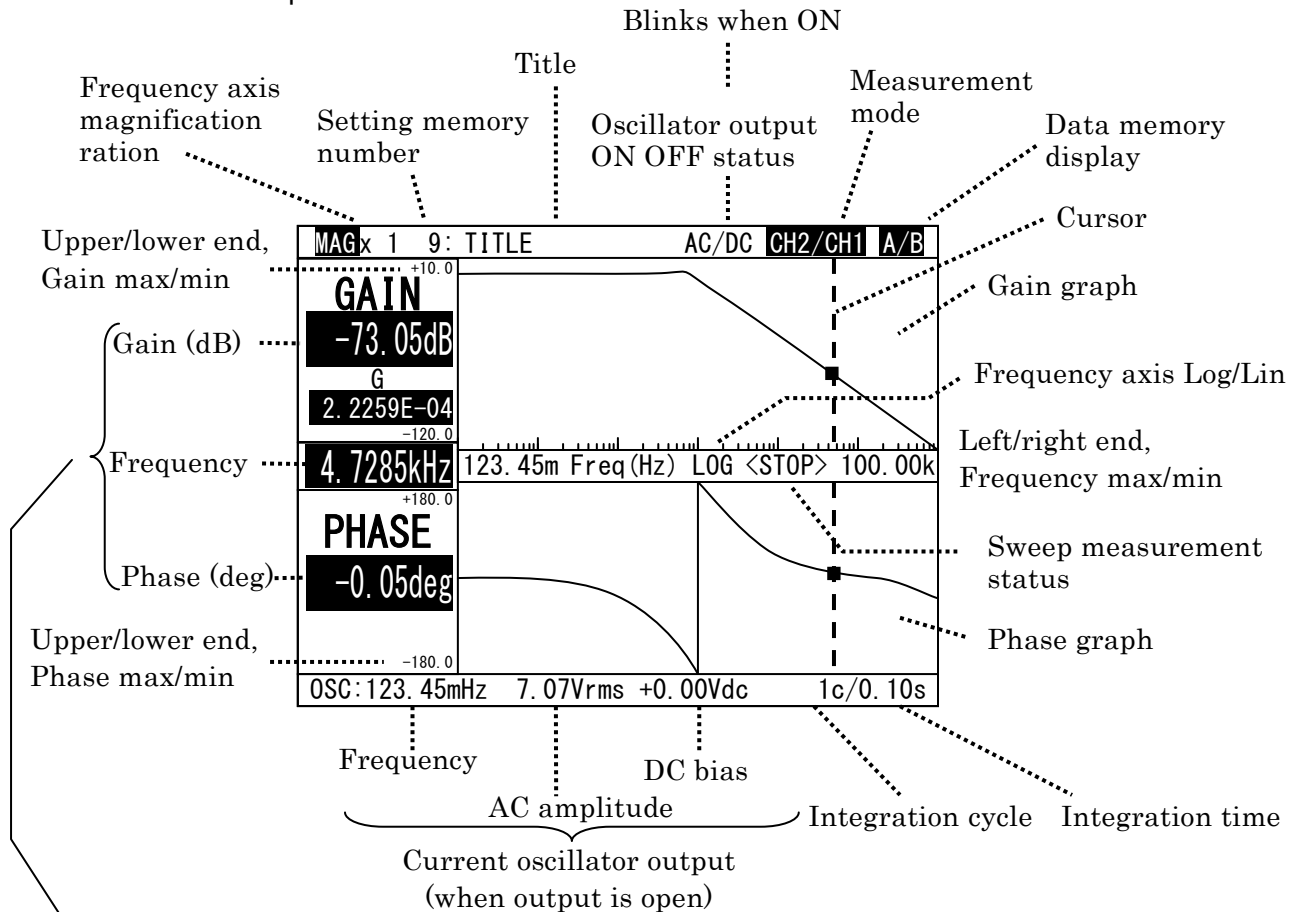

During measurement: latest measurement value the cursor (vertical axis) is not displayed.
When STOP: value for the cursor position

When the graph axis (measured values display format) settings are “G, P-F” or “a-b”, the following values are displayed according to the settings.

Below Gain (dB): linear gain G or real value a of complex gain a + jb

Below Phase: imaginary value b of complex gain

Figure 3-13 Sweep measurement screen

■ Measured values reading

The sweep measurement screen allows you, during the STOP mode, to check the gain and phase at each frequency by moving the frequency cursor (vertical line on the graph) using the Left/Right cursor keys < >. The cursor moving speed (the number of points to move at one time) can be adjusted using the m key and k key in the range of $\times 1/\times 2/\times 4/\times 10/\times 100$. Pressing the m key increases the speed. Upon specifying the moving speed, the speed is displayed on the screen for a short duration.

■ Frequency axis magnification

When many frequency points are clustered and cannot be resolved, using the UP cursor key \triangle allows you to magnify the frequency axis near the cursor by $1\times/2\times/4\times/8\times/16\times$. Use the Up/Down cursor keys \triangle/∇ (MAG) to magnify/reduce the display as needed.

3.5.9 Spot Measurement

In spot measurement, the measurement is executed at one set frequency point and the numerical values of the measured results are then displayed.

Spot measurements are made by operating the SPOT key located on the MEASUREMENT part of the front panel.

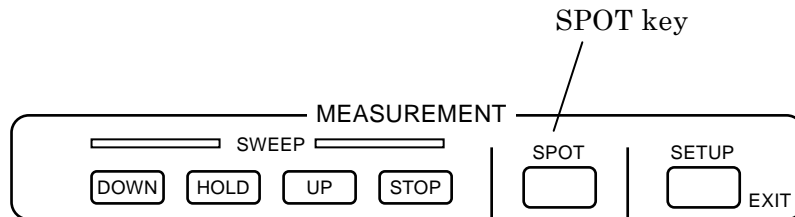

Figure 3-14 Spot measurement control key

The settings for measurements or display are made under the Spot menu screen.

☞ “3.5.6 Spot Menu Screen”

The main setup items are as bellow. For the possible settings range, check the comments in the lower side of the screen.

- AC Amplitude: OSC ac amplitude
- DC bias: OSC dc bias
- Integration time: MEAS integ. time
- Integration cycle: MEAS integ. cycle
- Phase minimum value: DISP spot phase min

The phase value is displayed within a range from the set phase minimum value to that value plus 359.99 deg.

It is independent from the sweep measurement graph phase minimum value.

- Repeat measurement: REPEAT on/off

Allows to take sequential measures if set to ON, or to take measures one by one by pressing the SPOT key if set to OFF. It is independent from the sweep measurement automatic sweep (sequential measures when HOLD).

Sequential measures can be stopped by pressing the STOP key. To resume, press the SPOT key. During the measurement, the Repeat status at the top left of the spot measure screen blinks.

3.5.10 Spot Measurement Screen

The Spot measurement screen displays the measured results as numerical values. The settings for measurements or display are made under the Spot menu screen.

☞ “3.5.6 Spot Menu Screen”

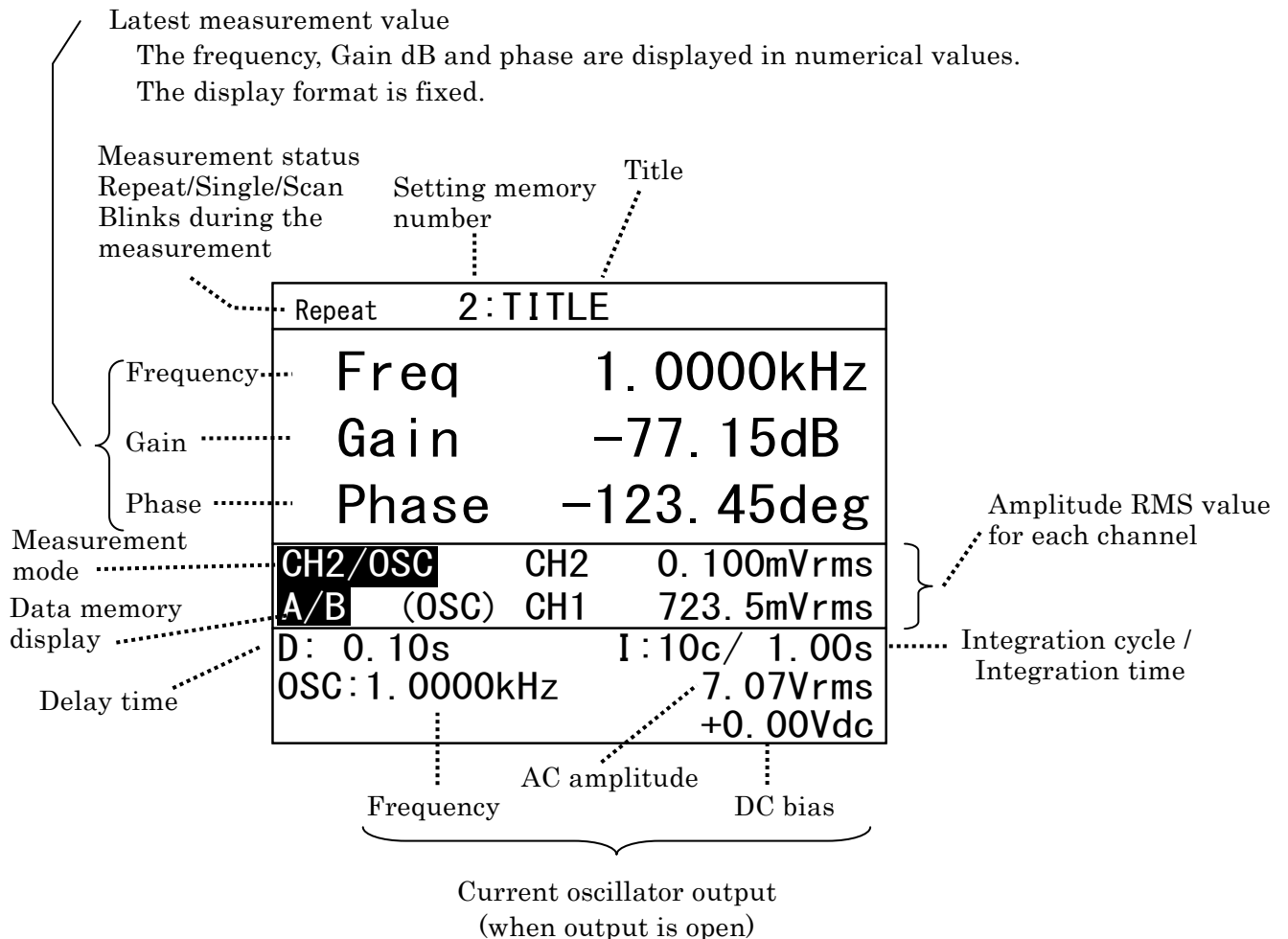

Figure 3-15 Spot measurement screen

In the spot measurement mode, you can perform a GO/NG evaluation for gain (dB) and phase (deg).

☞ “4.3 Result Evaluation”

■ About amplitude display

It is possible to monitor the signal's amplitude from FRA5022's spot measurement screen.

The amplitude measurement value is the RMS value of the measured frequency's fundamental wave (sine wave). In FRA, the noise components that differ from the measured frequency are not measured. It is not possible to display RMS values including noise or distortion like with a general voltmeter or peak values observed with an oscilloscope.

3.5.11 Measured Values of Excessive Input

When the input signal to the analyzer CH1 or CH2 exceeds the measurement range ($\pm 10V$), the gain obtained will be displayed as the maximum value that can be displayed on FRA5022. Below are the actual values displayed:

- Gain (dB): +199.99dB
- Phase: 0.00deg
- Gain (linear), a, b: +9.9999E+9

4. ADVANCED OPERATIONS

4.1	Setup Screen	4-2
4.1.1	Setup Screen Display	4-2
4.1.2	Sweep Setup Screen	4-2
4.1.3	Spot Setup Screen	4-3
4.1.4	Oscillator Setup Screen	4-3
4.2	Settings Memory	4-4
4.2.1	Setting Memory Description	4-4
4.2.2	Setting Memory Setup Items	4-4
4.2.3	Setting Memory Operation	4-5
4.3	Result Evaluation	4-6
4.3.1	Evaluation Range Setting	4-6
4.3.2	Evaluation Display	4-6
4.4	Scan Measurement	4-7
4.4.1	Scan Related Setup Items	4-7
4.4.2	Scan Measurements Operation and Function	4-7
4.5	Servo System Measurement	4-9
4.6	Data Memory	4-12
4.7	Equalizer	4-13
4.8	Oscillator Output Terminal Change Rate Limit (SLOW)	4-14

4.1 Setup Screen

4.1.1 Setup Screen Display

When the Sweep measurement screen or the Spot measurement screen is displayed, it is possible to display a summary setup screen of the most used setup items (Quick setup screen) in the lower part of the monitor by pressing the MEASUREMENT or the OSCILLATOR SETUP/EXIT key. By pressing it one more time the screen reverts to the measurement screen.

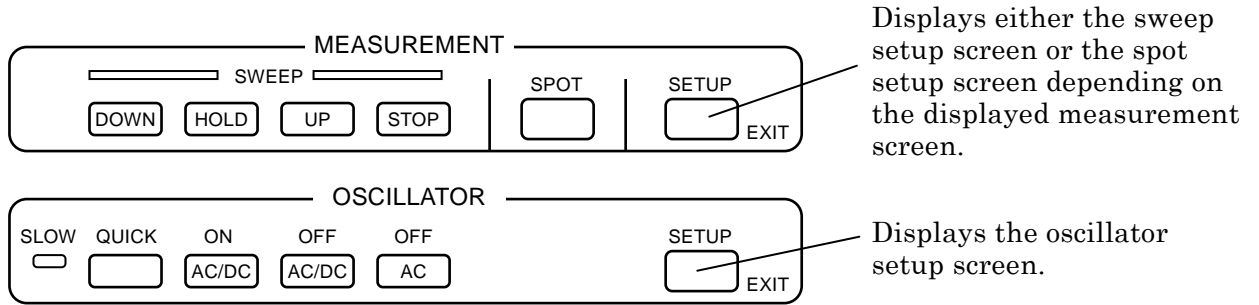

Figure 4-1 Setup key

4.1.2 Sweep Setup Screen

Pressing the MEASUREMENT SETUP/EXIT key during a sweep measurement displays a summary setup screen of the most used sweep measurement setup items.

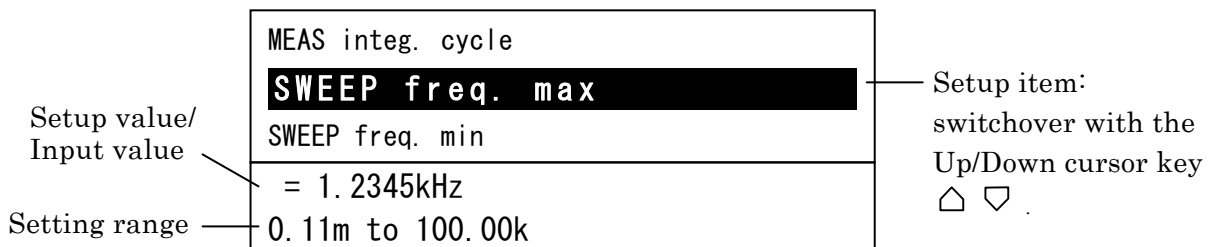

Figure 4-2 Sweep setup screen (ex.)

The setup items for the sweep setup screen are a sweep menu screen subset, as shown below.

- | | |
|-----------------------------------|-------------------|
| ■ Integration time: | MEAS integ. time |
| ■ Integration cycle: | MEAS integ. cycle |
| ■ Maximum frequency: | SWEEP freq. max |
| ■ Minimum frequency: | SWEEP freq. min |
| ■ Graph Y-axis automatic scaling: | DISP scale |
| ■ Graph gain maximum value: | DISP gain max |
| ■ Graph gain minimum value: | DISP gain min |
| ■ Graph phase maximum value: | DISP phase max |
| ■ Graph phase minimum value: | DISP phase min |

4.1.3 Spot Setup Screen

Pressing the MEASUREMENT SETUP/EXIT key during a spot measurement displays a summary setup screen of the most used spot measurement setup items.

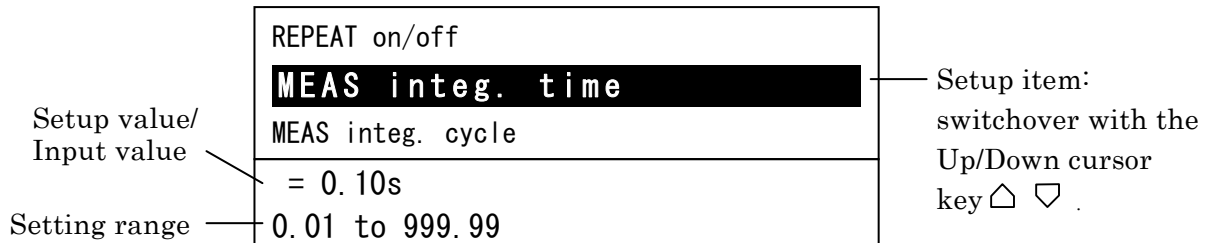

Figure 4-3 Spot setup screen (ex.)

The setup items for the spot setup screen are a spot menu screen subset, as shown below.

- Integration time: MEAS integ. time
- Integration cycle: MEAS integ. cycle
- Repeat measurement: REPEAT on/off

4.1.4 Oscillator Setup Screen

Pressing the OSCILLATOR SETUP/EXIT key during a sweep or a spot measurement displays a summary setup screen of the most used oscillator setup items.

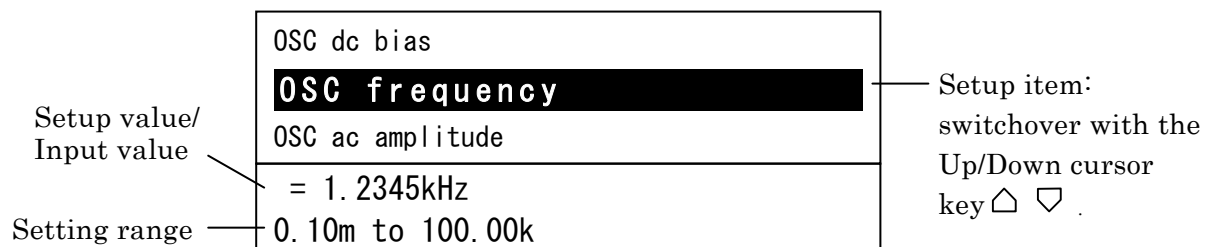

Figure 4-4 Oscillator setup screen (ex.)

The setup items for the oscillator setup screen are a sweep menu and spot menu screen subset, as shown below.

- Oscillator frequency: OSC frequency
- Oscillator AC amplitude: OSC ac amplitude
- Oscillator DC bias: OSC dc bias

4.2 Settings Memory

4.2.1 Setting Memory Description

FRA5022 can keep 10 settings groups in its setting memory. The memory contents is backed up by the battery and is not erased when it has been turned off.

During a measurement, it is possible to press a numerical key (0 to 9) to select the corresponding setting.

4.2.2 Setting Memory Setup Items

The setup items for each setting memory are shown in the table below. The items displayed per screen are limited.

Table 4-1 Setup items and screen handling

Setting items	Notation on screen	Sweep menu	Sweep setup	Spot menu	Spot setup	Oscillator setup
Title	TITLE	✓		✓		
Frequency	OSC frequency	✓		✓		✓
AC Amplitude	OSC ac amplitude	✓		✓		✓
DC bias	OSC dc bias	✓		✓		✓
Measurement mode	MEAS mode	✓		✓		
Integration time	MEAS integ. time	✓	✓	✓	✓	
Integration cycle	MEAS integ. cycle	✓	✓	✓	✓	
Delay time	MEAS delay time	✓		✓		
Frequency axis	SWEEP freq. axis	✓				
Maximum frequency	SWEEP freq. max	✓	✓			
Minimum frequency	SWEEP freq. min	✓	✓			
Frequency point	SWEEP points	✓				
Automatic sweep	SWEEP man/auto	✓				
Repeat measurement	REPEAT on/off			✓	✓	
Data memory display	DISP data memory	✓		✓		
Graph axis measurement values display format	DISP coordinates	✓		✓		
Graph Y-axis automatic scaling	DISP scale	✓	✓			
Graph gain maximum value	DISP gain max	✓	✓			
Graph gain minimum value	DISP gain min	✓	✓			
Graph phase maximum value	DISP phase max	✓	✓			
Graph phase minimum value	DISP phase min	✓	✓			
Spot phase minimum value	DISP spot phase min			✓		
CH1 Excessive input detection voltage	OVER level ch1	✓		✓		
CH2 Excessive input detection voltage	OVER level ch2	✓		✓		
Operation with excessive input	OVER response	✓		✓		
Result evaluation Gain maximum value	SPOT GO/NG G max			✓		
Result evaluation Gain minimum value	SPOT GO/NG G min			✓		
Result evaluation Phase maximum value	SPOT GO/NG P max			✓		
Result evaluation Phase minimum value	SPOT GO/NG P min			✓		



Setting items detailed contents → “3.5.5 Sweep Menu Screen”, “3.5.6 Spot Menu Screen”

4.2.3 Setting Memory Operation

During a measurement, it is possible to press a numerical key (0 to 9) to select the corresponding setting.

Regarding AC amplitude and DC bias, switching of setting memory will only change the setting values. The OUTPUT OSCILLATOR terminal output voltage will not change until the ON AC/DC key is pressed.

The following operations are possible under the sweep menu or spot menu screen.

- **Selecting setting memory** **SETTING memory**
 Selects a setting memory among the 10 possible.
 On the menu screen or setup screen, it is possible to modify the selected setting memory directly.
- **Setting each item**
 Except for some, the setup items displayed on the sweep menu screen or spot menu screen are a subset of the setting memory. The setting items displayed in common with the sweep menu and spot menu are the items shared in the setting memory. Changing these items on one menu will also change the corresponding items on the other.
- **Protecting setting memory** **SETTING lock**
 It is possible to lock a setting memory currently displayed. When locked, all the settings, except those that are free, will be unavailable.
 It is not possible to simultaneously lock or free all of the 10 setting memories.
- **Initializing each setting memory** **SETTING clear**
 Reverts the setting memory contents to the initial values. Does not affect other setting memories.
 Initial values  "Table 3-1 Setting items and initial values"
 It is possible to revert all the setup items including the setting memories to their initial values under the SYSTEM menu screen.
 Initialize all  "3.5.4 System Menu Screen" **INITIALIZE all**
- **Copying setting memory** **SETTING copy to**
 Copies the contents of the currently displayed setting memory to another setting memory.
 If the displayed memory is locked, the copy destination will be unlocked (free).
 If the copy destination is locked, copying results in an error.

4.3 Result Evaluation

In spot measurements, it is possible to automatically evaluate whether the gain (dB) and phase measured values fit within a specified range and to display the results. Result evaluation cannot be performed on gain (linear) or complex gain $a+jb$.

4.3.1 Evaluation Range Setting

To execute the result evaluation, set the following setup items under the spot menu screen.

If minimum value \geq maximum value the evaluation will not be executed.

- Result evaluation Gain maximum value SPOT GO/NG G max
- Result evaluation Gain minimum value SPOT GO/NG G min
Value range: -199.99 to +199.99 dB, resolution 0.01 dB
- Result evaluation Phase maximum value SPOT GO/NG P max
- Result evaluation Phase minimum value SPOT GO/NG P min
Value range: -360.00 to +360.00 deg, resolution 0.01 deg

4.3.2 Evaluation Display

Evaluation results are displayed on the spot measurement screen.

- ▲: OVER is displayed when measured value $>$ maximum value.
- ▼: UNDER is displayed when measured value $<$ minimum value.
- ▲▼ neither of both is displayed when minimum value \leq measured value \leq maximum value.

When the evaluation result is either OVER or UNDER, the item name is displayed in red.

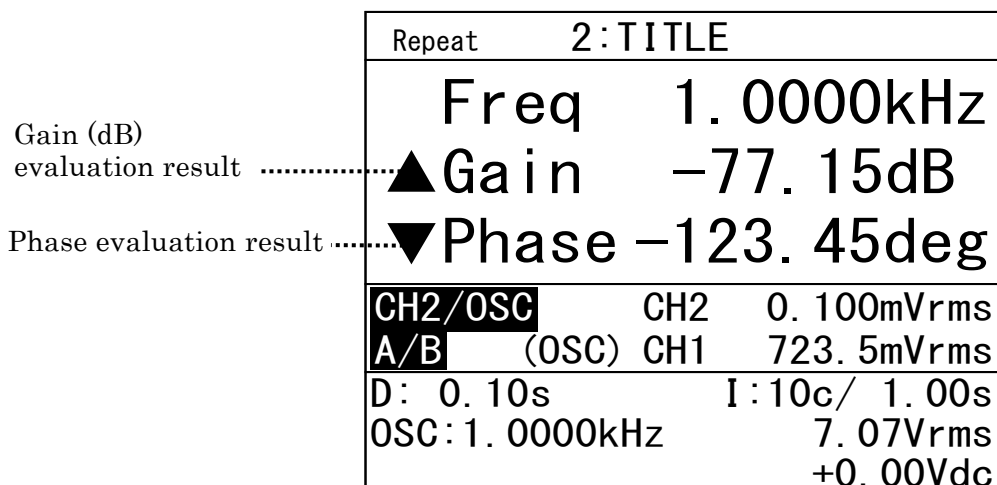

Figure 4-5 Evaluation result display

4.4 Scan Measurement

It is possible to execute measurements in spot measurement by sequentially switching the setting memories.

4.4.1 Scan Related Setup Items

Scan upper limit: SCAN limit → System menu screen
 Automatic scan: SCAN auto/man → System menu screen
 Result evaluation: SPOT GO/NG G max / min, P max / min → Spot menu screen

4.4.2 Scan Measurements Operation and Function

Pressing the m/SCAN key when in spot measurement allows the following measurements depending on the scan measurement auto/manual settings.

■ For auto scans

It is possible to execute a batch result evaluation of a number of settings.

Pressing the m/SCAN key will switch the setting memory from setting memory No. 0 up to the scan maximum and execute a measurement once for each setting. The scan will stop when reaching its maximum. If the result evaluation gives “measured value < minimum value” or “measured value > maximum value”, the scan will stop at that point. When the scan stops, the spot measurement repeat setting is ignored and the measurement is stopped too.

By pressing the k/▼ key, it is possible to have the reverse effect of pressing the m/SCAN key and have the measurement be executed from the scan maximum down to the setting memory No. 0. It is possible to interrupt a scan measurement by pressing the STOP key during the measurement.

■ For manual scans

By pressing the m/SCAN key, it is possible to switch to the succeeding setting memory number and execute a measurement.

Setting memory above or equal to the scan maximum limit will switch to setting memory No. 0.

By pressing the k/▼ key, it is possible do the opposite of pressing m/SCAN key: to switch to the preceding setting memory number and execute a measurement. Setting memory above the scan maximum limit or setting memory No. 0. will be switched to the scan maximum setting memory.

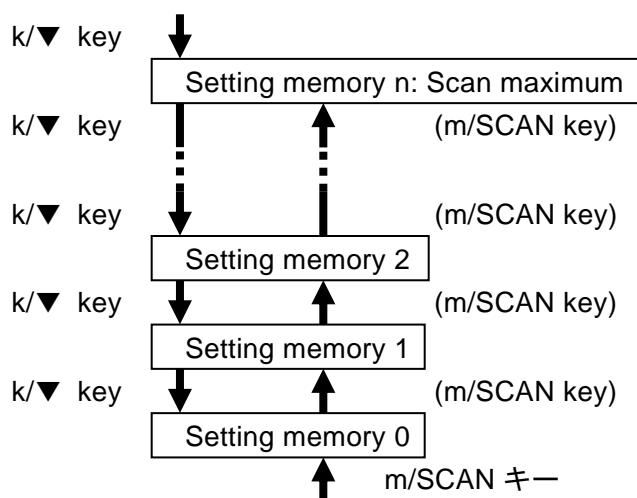

Figure 4-6 Scan measurement

During a scan measurement, the previous measurement value is retained in the display, even after the setting memory is switched, until a new measurement value is obtained.

If the oscillator AC amplitude or DC bias is modified by a setting memory switch during a scan measurement, the values will immediately be reflected in the output voltage. It is not necessary to use the ON AC/DC key. The output change rate limit (SLOW) is ineffectual. The output will be immediately change as if per QUICK, even if SLOW is set.

Even after a scan measurement is over, the oscillator's output will remain ON and the AC amplitude and DC bias will remain at their last values.

4.5 Servo System Measurement

It is possible to obtain the servo system loop gain $A\beta$ by inserting FRA5022 oscillator into a control loop and to measure the signal's V_1 and V_2 before and after.

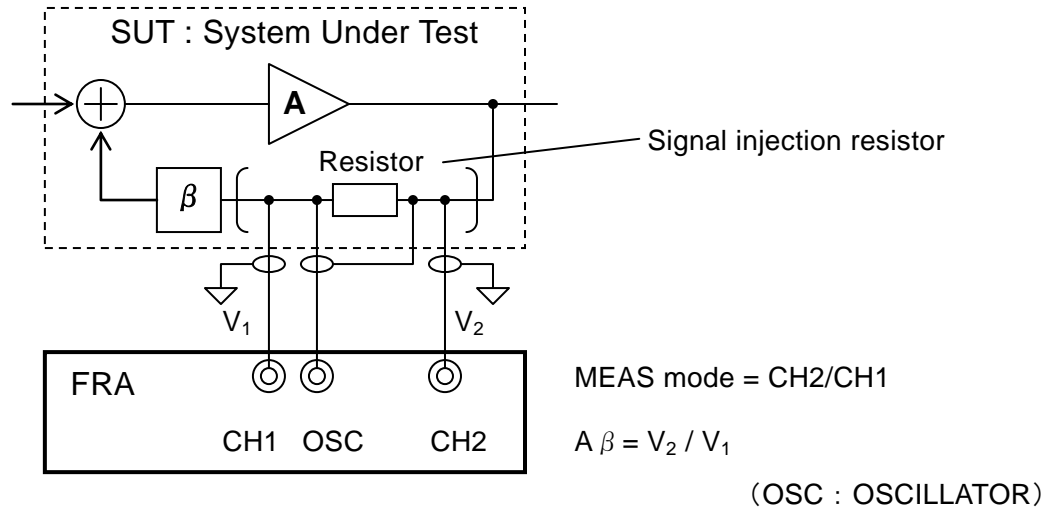

Figure 4-7 Connection for servo system measurement

⚠ WARNING

- When the control loop is cut, a significant output is generated. The system under test may be damaged and users can be put at risks. Use a signal injection resistor to ensure that even if the connection to FRA5022's oscillator is cut the control loop is not opened. Firmly fix the resistor to prevent it from coming away.
- When the input signal level (AC amplitude, etc.) is too strong, a significant output is generated. The system under test may be damaged and users can be put at risks. Use a small signal level first and slowly increase it to ensure you work in safe conditions.
- The connection between FRA5022 and the system under test may generate unexpected behavior like an oscillation. There is a few 100pF floating capacitance (capacitance vs the case) for the analyzer's input or the oscillator's output, together with the connection cable stray capacitance, it is possible to put the system under test into an unstable state.

⚠ CAUTION

FRA5022's maximum output current is $\pm 100\text{mA}$.

If the influence on the system under test response is not too important, set the resistor for the input signal inserted to the circuit to at least $50\ \Omega$. During the measurement, this resistor value in parallel with the oscillator's output resistance of $50\ \Omega$ will be inserted into the control loop. If a lower resistor value is inserted, modify AC amplitude and DC bias so that the current does not exceed the maximum output current. A combined peak value not exceeding $\pm 5\text{V}$ is safe.

When enforcing operation safety measures, it is possible that for small input signal level, noise causes dispersion in the measurement. In such cases, it is possible to maintain measurement reliability and operation safety by splitting the frequency range and setting the appropriate signal level for each range.

■ 5055 Signal injector/probe use

When connecting directly the system under test to FRA5022, the influence of the measurement cable capacitance or of FRA5022's input impedance can put the system under test into an unstable state and its response can be seen as changing. In such cases, it is possible to reduce the influence on the system under test by using a separately sold 5055 Signal Injector/Probe. Details about 5055 conditions of use or measurement are found in the 5055 Instruction Manual.

5055 can get its power supply from FRA5022 rear panel's AUX connector. 5055 comes with 2 different FRA connection cables. Use the one that connects to the AUX connector.

■ About handling of a floating system under test

When the system under test is not grounded, the signal ground electrical potential varies. For it, the FRA5022's insulation voltage exceeds, common mode noise is made and may influence the measurement. In case of doubt, use an oscilloscope to check the signal ground electrical potential.

High frequency fluctuation can be reduced by grounding the system under test through a bypass capacitor.

WARNING

FRA5022's signal dielectric voltage is 42Vpk.

When there are risks that this range will be exceeded, ground directly or indirectly (with the use of an appropriate impedance) the signal ground of the system under test, and use it within this range. It is possible to use a resistor or a varistor or any voltage controlling element as the impedance element.

■ Measurement voltage range magnification

FRA5022's internal oscillator has a dielectric voltage of 42Vpk against the case. It is thus possible directly input a signal with an electric potential of up to about $\pm 40\text{V}$ to the circuit.

On the other side, the analyzer input voltage range is limited to $\pm 10\text{V}$. It is not possible to measure directly when a signal exceeds this range. Even in such cases, it is possible make measurement by means of other methods like attenuate a signal with an attenuator or shift the analyzer ground electric potential to an external circuit. In the case a signal is attenuated it becomes necessary to compensate the frequency response for this attenuation.

☞ "4.7 Equalizer"

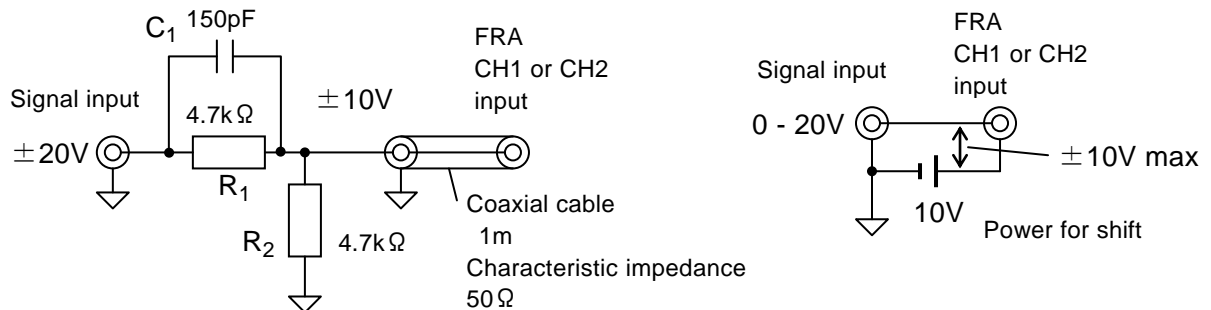

When the signal source impedance is sufficiently low, if the parallel values of R_1 and R_2 are set below a few $\text{k}\Omega$, the errors can be reduced.

When changing the attenuation ratio it is set to $C_1 R_1 \doteq R_2 C_2$. Here, $C_2 = \text{cable capacitance} + \text{FRA input capacitance}$. In the case of a 1m coaxial cable of 50Ω , $C_2 = \text{about } 150\text{pF}$. The higher the parallel values of R_1 and R_2 and the higher the frequency, the bigger will be the errors. Use attenuation only after evaluating thoroughly the general accuracy.

Power for the shift can be a battery with low internal resistance.

When the signal level difference is big, split the shift power for CH1 and CH2 to prevent inter-channel interference. Do not apply to locations where the original voltage exceeds FRA5022's non-destructive maximum input voltage, $\pm 24\text{V}$.

Figure 4-8 Measurement voltage range magnification example

4.6 Data Memory

FRA5022 has two measurement results storage memories (data memory A, data memory B).

The latest measured data is always put to data memory A.

The following data memory operations are possible.

<System menu screen>

■ Measurement data recording STORE data A-->B

Copies the contents of data memory A to data memory B. The contents of data memory A stays in place.

<Sweep Menu Screen, Spot Menu Screen>

■ Data memory display DISP data memory

It is possible to select a display method for the data in data memory.

A: Displays the contents of data memory A.

B: Displays the contents of data memory B.

A&B: Displays the contents of data memory A and B (when in graph display).

A/B: Displays the vector ratio (magnitude ratio, phase difference).

4.7 Equalizer

It is possible to use the data memory display setting A/B as an equalizer function to compensate for the errors due to the measurement's peripheral circuits.

Remove the SUT (system under test), connect directly the actual measurement terminal and measure the peripheral circuit response, store the data in data memory B. When you measure SUT again, the data is stored in A. When setting the data memory display to A/B in the sweep menu screen, the vector ratio (magnitude ratio, phase difference) between A and B is obtained as SUT characteristics by subtracting the characteristics of the peripheral circuit from those of A.

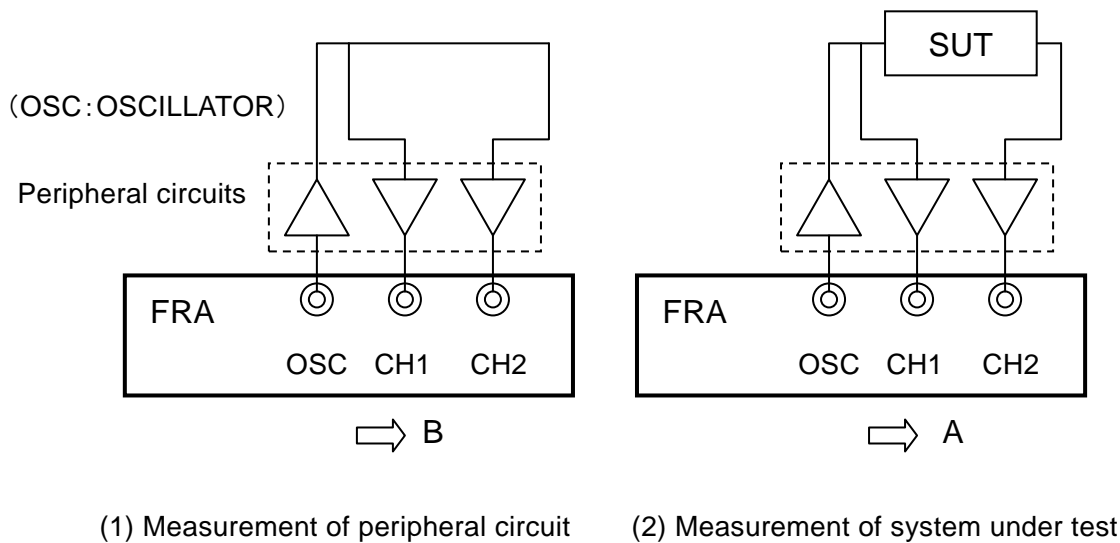

Figure 4-9 Connection with equalizer

The data memory display A/B displays the frequency range and frequency points of the data memory A. In the frequency range where the data memory B has no data, no data is displayed. When the values in data memory B are not matching those in data memory A with respect to frequency, the value of data memory B at the corresponding frequency is estimated by interpolating the values available in the vicinity of the relevant frequency point. For easier understanding, it would be helpful to match the frequency range (upper limit, lower limit) with the values at the frequency points obtained by performing measurements on the peripheral circuit and the system under test.

The base data memory B should store clean data. Avoid using data with variance due to noise, or data obtained by repeating UP/DOWN during sweep. Otherwise, the calculation results of A/B may vary even if the data in the data memory A is consistent.

The analyzer input capacitance of FRA5022 has a slight voltage dependency. For this reason, equalizing may not be effective in reducing errors when the signal source impedance or frequency is high.

4.8 Oscillator Output Terminal Change Rate Limit (SLOW)

In case the output changes abruptly due to shocks during a vibration test, etc., the system under test can be damaged.

To prevent this, it is possible to slowly change FRA5022's oscillator output voltage.

- Use the MENU key to display the menu screen, select <SYSTEM> tab with the Left/Right cursor keys < > .
- Use the Up/Down cursor keys \triangle ∇ to select OSC slow on/off and press the key 1.
OSC slow on/off 0) Quick only 1) Slow enable

While the SLOW lamp is illuminating, the AC amplitude and DC bias of the output changes linearly within a duration of up to 10 seconds.

To change the output immediately using the ON/OFF key, press the QUICK key to turn off the SLOW lamp. After the output is changed immediately for only once, the SLOW lamp illuminates again.

When Slow enable is selected for the output terminal change rate limit, the SLOW lamp alternately turns ON/OFF with each press of the QUICK key. The AC amplitude range is fixed at a higher voltage range. This prevents any discontinuity in AC amplitude change due to range switching. Note, however, that the AC amplitude accuracy deteriorates when the AC amplitude is set to less than $1V_{\text{peak}}$ ($0.707V_{\text{rms}}$).

Switching the setting of "OSC slow on/off" may inevitably change the range. For this reason, ensure that the output terminal change rate limit is set while the output of FRA5022 is not in use.

5. REMOTE CONTROL

5.1	Preparations Before Use	5-2
5.1.1	USB Preparations	5-2
5.1.2	GPIB Preparations	5-2
5.1.3	Remote Control Interface Selection	5-2
5.1.4	USB Device Identification	5-3
5.1.5	GPIB Address Setting	5-3
5.1.6	Necessary Precautions When Using GPIB	5-3
5.2	Remote State Display and Cancellation	5-3
5.3	Command List	5-4
5.4	Command Tree	5-9
5.5	Command Explanation	5-10
5.5.1	Summary of Terms	5-10
5.5.1.1	Subsystem Commands	5-10
5.5.1.2	Path Separator	5-10
5.5.1.3	Command Strings Simplification	5-10
5.5.1.4	Implicit Keywords	5-11
5.5.2	Command Detailed Explanations	5-11
5.5.2.1	Common Commands	5-12
5.5.2.2	Subsystem Commands	5-15
5.6	Status System	5-32
5.6.1	Status System Overview	5-32
5.6.2	Status Byte	5-33
5.6.3	Standard Event Status	5-34
5.6.4	Operation Status	5-36
5.6.5	Overload Status	5-38
5.7	Programming Cautions	5-39

5.1 Preparations Before Use

FRA5022 can be remote controlled by GPIB or USB-TMC (TMC: Test and Measurement Class). By sending program messages from the controller it is possible to control the device similarly to panel operations and to receive measurement values or setting status as response messages.

- The interface assumes that GPIB or USB is used in a favorable environment. Avoid using them in a noisy environment.

5.1.1 USB Preparations

Install the USB-TMC class driver to the controlling computer and connect with a USB cable which is sold commercially. It is possible to download the driver install file from National Instruments Corporation's web site. The driver installation process is described below.

- 1) Go to the National Instruments Corporation web site and search for the VISA Run-time Engine page.
- 2) From VISA Run-time Engine's page, download VISA Run-time Engine. User registration is required. Download VISA Run-time Engine Ver3.3 or superior.
- 3) The downloaded file is a self extracting archive. Install after extraction.
- 4) After the process is correctly completed, the USB-TMC class driver is installed.

The above information is effective at the time of the creation of this instruction manual. For more details, see the National Instruments Corporation's web site. The web site address or provided services can be modified without prior notice.

5.1.2 GPIB Preparations

Install a GPIB card/controller board on the controlling computer and connect the board/controller card to FRA5022 using a GPIB cable commercially available. For details, see the operation manual of the GPIB card/controller board.

5.1.3 Remote Control Interface Selection

In FRA5022 it is possible to select GPIB or USB as remote control interface. It is not possible to use GPIB and USB simultaneously. Select either one from the system menu screen. First, press the MENU key to display the menu screen. Use the left/right cursor keys ◀ ▶ to select the <SYSTEM> tab. Use the up/down cursor keys ▲ ▼ to select the following items and select either GPIB or USB.

Items: INTERFACE connect
Value range: 0) GPIB 1) USB

5.1.4 USB Device Identification

FRA5022 is automatically identified by connecting it with USB to the computer on which USB-TMC class driver is installed. FRA5022 is identified internally by the following parameters.

- Vendor ID: 3402 (0x0D4A) Indicates NF Corporation
 Decimal (hexadecimal) notation
- Product ID: 15 (0x000F) Indicates FRA5022
- Serial number: Device serial number This number is a unique number.

It is possible to check the serial number from the system menu screen.

Items: Serial Number

5.1.5 GPIB Address Setting

With GPIB the system devices are identified by a device- specific address. Each device must be setup with a unique GPIB address. The GPIB address for FRA5022 can be set via the system menu screen.

Items: INTERFACE address

Value range: 0 - 30

5.1.6 Necessary Precautions When Using GPIB

- Manipulate the GPIB connector only when all the devices connected to the bus have their power turned off.
- When using GPIB, turn the power on for all the devices connected to the bus.
- The number of devices connectable to the bus from GPIB, including the controller, is 15.

Cable length has the following restrictions.

- total cable length \leq (2m×number of devices or 20m, whichever is shorter)
- length for 1 cable \leq 4m
- Each device must be setup with a unique GPIB address. Devices connected to the bus can be damaged if they are identified with the same address.

5.2 Remote State Display and Cancellation

FRA5022 can be operated in the remote state or local state.

In the local state, all the panel operations are enabled. Normally, the device is switched to the remote state when it is operated via GPIB or USB. Once switched to the remote state, the REMOTE lamp on the front panel illuminates, indicating that all the panel operations are disabled except for swtching the device back to the local state.

Except when the device is in the local lockout state, pressing the BS/LOCAL key switches the device back to the local state from the remote state. Setting the device to the local lockout state via the controller allow you to prevent the device from being operated inadvertently. When in the local lockout state, switching the device back to the local state is possible only by sending a message from the controller but not by pressisng BS/LOCAL key. Actually, this message involves operations of sending GTL command or resetting REN line to False. Note that, when the GPIB cable is disconnected, the device returns to the local state because REN line is reset to False. Also, when the USB cable is disconnected, the device is reset to the local state.

5.3 Command List

FRA5022 commands are separated into the common commands defined by IEEE488.2 and subsystem commands that reflect device-specific functions.

The FRA5022 subsystem commands are shown in table 5-1. Common commands supported by FRA5022 are shown in table 5-2. The meaning of codes used in table 5-1 and table 5-2 are explained below. It is possible to omit the keywords lower case parts.

- Commands that make inquiries are called queries and are ended with a question mark. In the command list table, queries are omitted for the functions that can make both settings and inquiries.
- Keywords shown in square brackets ([]) are those that support omission (implicit keyword)
- The vertical bar (|) indicates the possibility to select a keyword from several keywords.

Table 5-1 FRA5022 subsystem command list 1/3

Function	Command
	CALibration subsystem
Self calibration	:CALibration[:ALL]?
	DISPlay subsystem
Data display format	:DISPlay:COORdinateS
Data memory display	:DISPlay:DATA:MEMory
Copy to data memory B	:DISPlay:DATA:STORe
Spot measurement phase minimum	:DISPlay:PHASe:MINimum
Graph automatic scaling	:DISPlay:WINDow:SCALE:MODE
Graph gain dB maximum value	:DISPlay:WINDow:TRACe:GAIN:MAXimum
Graph gain dB minimum value	:DISPlay:WINDow:TRACe:GAIN:MINimum
Graph phase maximum value	:DISPlay:WINDow:TRACe:PHASe:MAXimum
Graph phase minimum value	:DISPlay:WINDow:TRACe:PHASe:MINimum
	INPut subsystem
Excessive input detection level	:INPut{1 2}:VOLTage:OVERload[:LEVel]
Processing excessive input	:INPut:VOLTage:OVERload:RESPonse
	MEASure subsystem
Measurement delay time	:MEASure:DELay[:TIME]
Integration cycle	:MEASure:INTegrate:CYCLE
Integration time	:MEASure:INTegrate:TIME
Measurement mode	:MEASure:MODE
Spot continuous measurement	:MEASure:SPOT:REPeat
	MEMory subsystem
Setting memory copy	:MEMory:COpy
Setting memory deletion (initialization)	:MEMory:DELeTe
Settings memory modification status	:MEMory:STATe
Settings memory title	:MEMory:TITle

Table 5-1 FRA5022 subsystem command list 2/3

Function	Command
	SENSe subsystem
Sweep measurement data readout	:SENSe:DATA:SWEep[:DATA]?
Sweep measurement points readout	:SENSe:DATA:SWEep:POINt?
Spot measurement data readout	:SENSe:DATA:SPOT[:DATA]?
Spot gain evaluation maximum	:SENSe:DATA:SPOT:LIMit:GAIN:MAXimum
Spot gain evaluation minimum	:SENSe:DATA:SPOT:LIMit:GAIN:MINimum
Spot phase evaluation maximum	:SENSe:DATA:SPOT:LIMit:PHASe:MAXimum
Spot phase evaluation minimum	:SENSe:DATA:SPOT:LIMit:PHASe:MINimum
Spot evaluation results readout	:SENSe:DATA:SPOT:LIMit:REPort?
	SOURce subsystem
Oscillator frequency	[:SOURce]:FREQuency[:IMMediate]
Measurement operation	[:SOURce]:SWEep:MEASure
Sweep operation mode	[:SOURce]:SWEep:MODE
Sweep frequency axis format	[:SOURce]:SWEep:SPACing[:TYPE]
Sweep frequency points	[:SOURce]:SWEep:SPACing:POINt
Sweep maximum frequency	[:SOURce]:SWEep[:LEVel]:MAXimum
Sweep minimum frequency	[:SOURce]:SWEep[:LEVel]:MINimum
Oscillator output SLOW status	[:SOURce]:VOLTage:SLOW:ENABLE
Oscillator output variation speed	[:SOURce]:VOLTage:SLOW[:STATe]
Oscillator output ON OFF	[:SOURce]:VOLTage:OUTPut[:STATe]
Oscillator DC bias	[:SOURce]:VOLTage:OFFSet[:IMMediate]
Oscillator AC amplitude	[:SOURce]:VOLTage[:LEVel][:IMMediate][:AMPLitude]
AC amplitude unit	[:SOURce]:VOLTage:UNIT

Table 5-1 FRA5022 subsystem command list 3/3

Function	Command
	STATus subsystem
Operation condition register	STATus:OPERation:CONDition?
Operation event enable register	STATus:OPERation:ENABLE
Operation event register	STATus:OPERation[:EVENT]?
Operation transition filter (1 → 0)	STATus:OPERation:NTRansition
Operation transition filter (0 → 1)	STATus:OPERation:PTRansition
Overload event enable register	STATus:OVERload:ENABLE
Overload event register	STATus:OVERload[:EVENT]?
	SYSTEM subsystem
Error contents query	SYSTEM:ERRor?
Error dismissal	SYSTEM:OVERload:RELEase

Table 5-2 Common command list

	Name	Function
*CLS	Clear status command	Clears status data
*ESE	Standard event status enable command / query	Sets/queries the standard event status enable register.
*ESR?	Standard event status register query	Queries the standard event status register.
*IDN?	Identification query	Queries the device identification information (model name etc).。
*OPC	Operation complete command / query	Sets standard event status register's OPC bit to be set to 1 after all the overlapped commands have been processed. When querying, returns 1 when all the processes are completed.
*RCL	Recall command	Switches the settings to the specified setting memory contents.
*RST	Reset command	Resets the device, sets output to OFF, reverts the settings related to measurements to initial values.
*SAV	Save command	Copies the current settings to the specified setting memory.
*SRE	Service request enable command/query	Sets/queries the service request enable register.
*STB?	Status byte query	Queries the status byte.
*TST?	Self-test query	Queries the self diagnosis results. *In FRA5022, 0 is always returned.
*WAI	Wait to continue command	Waits until all the overlapped commands have been processed before executing later commands.

■ Input buffer

- It is possible to send commands up to the size of the input buffer (about 4000 characters) at once.
- Sent commands are stored in the input buffer, interpreted sequentially and executed in order.
- If illegal commands are found at interpretation or at execution, an error is generated and the later command are not processed.
- When interpretation and execution are completed, the input buffer is cleared and it is possible to input next commands.

■ Device Clear

The device clear function (DCL, SDC) for interface allows you to:

- Clear the input buffer
- Clear the output queue
- Clear the waiting for overlapped command completion using *WAI, *OPC, or *OPC?

5.4 Command Tree

The FRA5022 subsystem command tree is shown on figure 5-1.

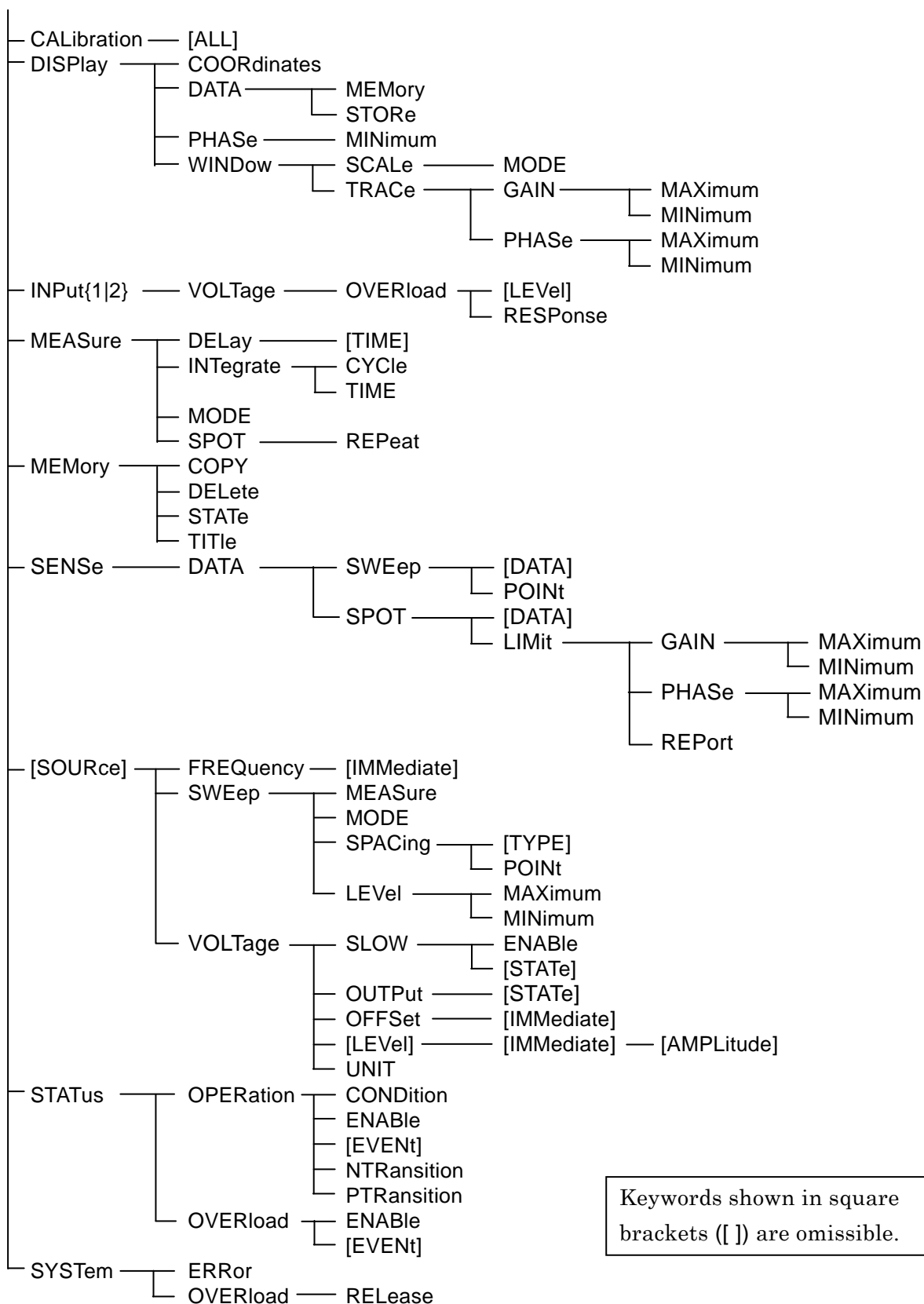

Figure 5-1 Command tree

5.5 Command Explanation

5.5.1 Summary of Terms

Summary of terms used are explained below.

5.5.1.1 Subsystem Commands

Commands are divided into groups depending on their function. Subsystem commands are arranged in a hierarchy. The colon (:) is defined as the path separator.

5.5.1.2 Path Separator

The path separator (:) separates the current keyword from the keywords one level lower. In a command string, each colon (:) indicates a displacement to the path one level below the current path.

When the colon (:) is found at the beginning of a command string it means “to set the current path to root”. It is possible to omit a heading colon (:).

```

:MEAS:DEL 999.99
  ↑   ↑     ↑   ↑
(1) (2)   (3) (4)

```

- (1) Set current path to root
- (2) MEASure subsystem command (MEASure is a root command)
- (3) MEASure subsystem attached DELay command
- (4) A space is required between the header and the parameters

By using a semi-colon (;) to separate a command string it is possible to access a subsystem command as the same level without changing the current path.

5.5.1.3 Command Strings Simplification

This operation manual displays the syntax of commands by using alphabet letters in upper or lower case to write commands (and a part of the parameters). The upper case strings are the abbreviated (short) form. Omitting the lower case part or including the whole string (long form) will be interpreted as the same command. It is not possible to use a part of the lower case characters as the abbreviation.

Upper and lower case are used only as an expedient means to explicit the form that can be shortened but the device makes no distinction whatsoever between the two. It is possible to use both simultaneously.

Ex.) :DISPlay:COORdinates?	→ :display:coordinates?	Acceptable (lower case)
	:DISP:coor?	Acceptable (mixed upper/lower case)
	:DISPL:COOR?	Not Acceptable (wrong intermediary abbreviated form)
	:DISP:COO?	Not Acceptable (omission over-abbreviated)

5.5.1.4 Implicit Keywords

Keywords shown in square brackets ([]) indicate the implicit keywords and are omissible. The device will handle the keyword exactly the same way whether the implicit keyword is abbreviated or not. The following examples show a device setting using both ways.

例) [:SOURce]:FREQuency:SWEep[:LEVel]:MAXimum
 → :SOUR:FREQ:SWE:LEV:MAX 12.3kHz
 :FREQ:SWE:MAX 12.3kHz

5.5.2 Command Detailed Explanations

The function and syntax of all the commands shown in “Table 5-1 FRA5022 subsystem command list” and “Table 5-2 Common command list” are explained below.

【Meaning of symbols】

- Keywords shown in square brackets ([]) are those that support omission (implicit keywords)
- Curly braces ({ }) indicate parameters in the command string.
- The vertical bar (|) indicates possibilities to select a keyword from several choices.
- Comparison marks (< >) indicate that a parameter such as numerical values and strings needs to be set.

【Parameters data format】

Symbol	Format	Ex.
<NR1>	Integer (numerical value)	123
<NR2>	Decimal point format without exponent (numerical value)	0.072
<NR3>	Decimal point format with exponent (numerical value)	4.99E+06
<CRD>	Strings	ALL
<SRD>	Strings in double quotation marks	“No error”
<bool>	Logical value	1, ON etc.

In the case of settings,

- Numerical data are accepted in any format (round off to appropriate value).
- Strings in quotation marks are accepted in single or double quotation marks.

【N.B.】

- Both commands and queries are called commands here. Queries are suffixed with “?”.
- Response messages to commands do not come with headers.
- When the data format of the response signal is string <CRD>, the response signal is an abbreviation (short form).

5.5.2.1 Common Commands

***CLS**

Description: Clears the following statuses.

- Standard event status register
- Operation event register
- Overload event register
- Status byte . . .  Note (see below)
- Error queue

Parameters: None

Example: *CLS

Note: The *CLS command does not directly clear the status byte register. Except for the MAV bit and the RQS bit, the status byte is indirectly cleared. It is possible to indirectly clear the MAV bit by clearing the input buffer with a device clear. It is possible to clear the RQS bit by reading out the status with the serial pole.

***ESE <std_event_enable>**

Description: Sets/queries the standard event status enable register.

Parameters: <std_event_enable> register contents, format <NR1>, range 0 to 255
 Details . . .  "5.6.3 Standard Event Status"

Example: *ESE 255

Response: <std_event_enable>

Query example: *ESE?

Response example: 255

***ESR?**

Description: Queries the standard event status register contents.
 The query clears all the standard event status register bits to 0.

Parameters: None

Response: Register contents, format <NR1>, range 0 to 255
 Details . . .  "5.6.3 Standard Event Status"

Query example: *ESR?

Response example: 128

***IDN?**

Description: Queries the model name etc.

Parameters: None

Response: Contents "name of manufacturer, model name, serial number, firmware version" format <SRD>

Query example: *IDN?

Response example: "NF Corporation,FRA5022,9025257,Ver1.00"

***OPC**

Description:	Sets standard event status register's OPC bit (BIT0) to be set to 1 after all the overlapped commands have been processed. Overlapped commands . . .  *WAI command explanations
Parameters:	None
Settings example:	*OPC
Response:	Format <NR1> Returns 1 if all the overlapped commands are completed. Even by running *OPC?, the standard event status register's OPC bit will not be cleared. To clear this, use Device Clear, *CLS, or *RST command.
Query example:	*OPC? (Example: Overlapped command; *OPC? <PMT> , where PMT refers to Program Message Terminator.)
Response example:	1

***RCL <setting_memory>**

Description:	Changes the measurement settings to the settings stored in the selected memory (recall).
Parameters:	<setting_memory> memory number, format <NR1>, range 0 to 9
Settings example:	*RCL 5

***RST**

Description:	Resets the device, sets the output to OFF, reverts the parameters related to measurements to their initial values (total initialization). Details . . .  "Table 3-1 Setting items and initial values" It is not possible to initialize to a specific display screen, even use a command such as *RST.
Parameters:	None
Settings example:	*RST

***SAV <setting_memory>**

Description:	Copies the currently used settings to the specified setting memory (save).
Parameters:	<setting_memory> memory number, format <NR1>, range 0 to 9
Settings example:	*SAV 5

***SRE <srq_enable>**

Description:	Sets the service request enable register.
Parameters:	<srq_enable> register contents, format <NR1>, range 0 to 255 Details  "5.6.1 Status System Overview"
Example:	*SRE 128
Response:	<srq_enable>

Query example: SRE?

Response example: 128

***STB?**

Description:	Queries the status byte register contents.
Parameters:	None
Response:	Register contents, format <NR1>, range 0 to 255 Details . . .  "5.6.2 Status Byte"
Query example:	*STB?
Response example:	128

***TST?**

Description:	Queries the self diagnosis results.
Parameters:	None
Response:	In FRA5022, "0" is always returned format <NR1>
Query example:	TST?
Response example:	0

***WAI**

Description:	Waits until all the overlapped commands have been processed before executing later commands. Refer to the explanations below.
Parameters:	None
Example:	*WAI

■ Overlapped commands and sequential commands

An overlapped commands is a command that allows for succeeding commands to be executed while it is being executed.

A sequential command is a command that does not allows for succeeding commands to be executed while it is being executed.

The following commands are overlapped commands. Commands not listed below are sequential commands.

[:SOURce:]SWEep:MEASure

If you don't want to execute an order until an overlapped commands is executed, use the *WAI command, the *OPC command or the *OPC? command.

Ex.) overlapped command 1; overlapped command 2; *WAI; sequential command
<PMT>

Here: PMT is Program Message Terminator

The waiting caused by the *WAI can be canceled with device clear.

Do not use *WAI for repeat measurement. If a spot measurement command is sent with repeat setting, the command will be executed during repeat measurement.

Therefore, if the subsequent commands are kept waiting by *WAI, they will be waiting forever and not be executed.

5.5.2.2 Subsystem Commands

:CALibration[:ALL]?

Description:	Executes self calibration.
Parameters:	None
Response:	format <NR1>, range 0/1 0: no errors, 1: error
Example:	CAL?
Response example:	0
Note:	Do not send another command before the self calibration is complete. Self calibration takes approximately 50 seconds. Create a control program that will not raise a timeout and send the subsequent commands before the response message of completed self calibration is received. If another command is sent before the self calibration is complete, some malfunction may follow. In case of any malfunction, sending the device clear command will restore the normal operation.

:DISPlay:COORdinateS <coordinates>**:DISPlay:COORdinateS?**

Description:	Sets/queries the graph display and other data display format.
Parameters:	<coordinates> graph axis (measurement value display format) format <NR1>, range 0/1/2 0: GdB, P-F, 1 : G, P-F, 2: a, b
Settings example:	DISP:COOR 0 sets the data display format to GdB, P-F.
Response:	<coordinates>
Query example:	DISP:COOR?
Response example:	0

:DISPlay:DATA:MEMory <data_memory>**:DISPlay:DATA:MEMory?**

Description:	Sets/queries the data memory display.
Parameters:	<data_memory> data memory format <NR1>, range 0/1/2/3 0: A, 1: B, 2: A&B, 3: A/B
Settings example:	DISP:DATA:MEM 0
Response:	<data_memory>
Query example:	DISP:DATA:MEM?
Response example:	0

:DISPlay:DATA:STORe

Description:	Copies the latest measurement data (data memory A contents) to data memory B.
Parameters:	None
Example:	DISP:DATA:STOR

:DISPlay:PHASe:MINimum <spot_phase_min>**:DISPlay:PHASe:MINimum?**

Description: Sets/queries the spot measurement phase minimum value.
Parameters: <spot_phase_min> phase minimum, format <NR2>, range -360.0 to 0.0 [unit deg]
Settings example: DISP:PHAS:MIN -180.0
Response: <spot_phase_min>
Query example: DISP:PHAS:MIN?
Response example: -180.0

:DISPlay:WINDow:SCALE:MODE <scale>**:DISPlay:WINDow:SCALE:MODE?**

Description: Sets/queries the graph display range automatic/manual value.
Parameters: <scale> display range, format <NR1>, range 0/1 0: Auto, 1: Manual
Settings example: DISP:WIND:SCAL:MODE 0
Response: <scale>
Query example: DISP:WIND:SCAL:MODE?
Response example: 0

:DISPlay:WINDow:TRACe:GAIN:MAXimum <gain_max>**:DISPlay:WINDow:TRACe:GAIN:MAXimum?**

Description: Sets/queries the graph gain dB maximum value.
Parameters: <gain_max> dB maximum, format <NR2>, range -179.9 to 180.0 [unit dB]
Settings example: DISP:WIND:TRAC:GAIN:MAX 120.0
Response: <gain_max>
Query example: DISP:WIND:TRAC:GAIN:MAX?
Response example: 120.0

:DISPlay:WINDow:TRACe:GAIN:MINimum <gain_min>**:DISPlay:WINDow:TRACe:GAIN:MINimum?**

Description: Sets/queries the graph gain dB minimum value.
Parameters: <gain_min> dB minimum, format <NR2>, range -180.0 to 179.9 [unit dB]
Settings example: DISP:WIND:TRAC:GAIN:MIN -120.0
Response: <gain_min>
Query example: DISP:WIND:TRAC:GAIN:MIN?
Response example: -120.0

:DISPlay:WINDow:TRACe:PHASe:MAXimum <phase_max>**:DISPlay:WINDow:TRACe:PHASe:MAXimum?**

Description:	Sets/queries the graph phase maximum value.
Parameters:	<phase_max> phase maximum, format <NR2>, range -359.9 to 360.0 [unit deg]
Settings example:	DISP:WIND:TRAC:PHAS:MAX 180.0
Response:	<phase_max>
Query example:	DISP:WIND:TRAC:PHAS:MAX?
Response example:	180.0

:DISPlay:WINDow:TRACe:PHASe:MINimum <phase_min>**:DISPlay:WINDow:TRACe:PHASe:MINimum?**

Description:	Sets/queries the graph phase minimum value.
Parameters:	<phase_min> phase minimum, format <NR2>, range -360.0 to 359.9 [unit deg]
Settings example:	DISP:WIND:TRAC:PHAS:MIN -180.0
Response:	<phase_min>
Query example:	DISP:WIND:TRAC:PHAS:MIN?
Response example:	-180.0

■ Frequency axis magnification ratio (MAG)

It is not possible to set a Bode diagram frequency axis magnification ratio with the remote control interface.

■ Cursor displacement speed

It is not possible to set the cursor displacement speed with the remote control interface.

:INPut[1|2]:VOLTage:OVERload[:LEVel] <over_level>

:INPut[1|2]:VOLTage:OVERload[:LEVel]?

Description: Sets/queries the excessive input detection level.
 Command prefix: with CH1: INPut1, with CH2: INPut2.
 When the channel specification is abbreviated to INPut: the value is set to CH1.

Parameters: <over_level> detection level, format <NR2>, range 0.01 to 19.99
 [unit Vrms]

Settings example: INP1:VOLT:OVER 3.00
 sets the excessive input detection level for CH1 to 3.00Vrms

Response: <over_level>

Query example: INP1:VOLT:OVER?

Response example: 3.00

:INPut:VOLTage:OVERload:RESPonse <over_response>

:INPut:VOLTage:OVERload:RESPonse?

Description: Sets/queries the process when excessive input is detected.

Parameters: <over_response> response
 format <NR1>,
 range 0/1/2/3 0: Lamp, 1: Beep, 2: Hold, 3: Off

Settings example: INP:VOLT:OVER:RESP 1

Response: <over_response>

Query example: INP:VOLT:OVER:RESP?

Response example: 1

:MEASure:DELay[:TIME] <delay>**:MEASure:DELay[:TIME]?**

Description: Sets/queries the measurement delay time.
 Parameters: <delay> measurement delay time, format <NR2>, range 0.00 to 999.99 [unit s]
 Settings example: MEAS:DEL 999.99
 Response: <delay>
 Query example: MEAS:DEL?
 Response example: 999.99

:MEASure:INTEgrate:CYCLE <integ_cycle>**:MEASure:INTEgrate:CYCLE?**

Description: Sets/queries the integration cycle.
 Parameters: <integ_cycle> integration cycle, format <NR1>, range 1 to 999 [unit cycle]
 Settings example: MEAS:INT:CYC 999
 Response: <integ_cycle>
 Query example: MEAS:INT:CYC?
 Response example: 999

:MEASure:INTEgrate:TIME <integ_time>**:MEASure:INTEgrate:TIME?**

Description: Sets/queries the integration time.
 Parameters: <integ_time> integration time, format <NR2>, range 0.01 to 999.99 [unit s]
 Settings example: MEAS:INT:TIME 999.99
 Response: <integ_time>
 Query example: MEAS:INT:TIME?
 Response example: 999.99

:MEASure:MODE <mode>**:MEASure:MODE?**

Description: Sets/queries the measurement mode.
 Parameters: <mode> measurement mode, format <NR1>, range 0/1 0: CH2/CH1, 1: CH2/OSC
 Settings example: MEAS:MODE 0
 Response: <mode>
 Query example: MEAS:MODE?
 Response example: 0

:MEASure:SPOT:REPeat <spot_repeat>

:MEASure:SPOT:REPeat?

Description: Sets/queries the spot measurement repeat value.
Parameters: <spot_repeat> repeat set
format <bool>, range OFF | 0: single / ON | 1: repeat
Settings example: MEAS:SPOT:REP ON
Response: <spot_repeat>, format <NR1>, range 0/1 0: single, 1: repeat
Query example: MEAS:SPOT:REP?
Response example: 1

■ Scan measurement

It is not possible to conduct the operations related to scan measurement with the remote control interface.

:MEMory:COpy {<source>, <destination>}

Description: Copies contents between setting memories.
Parameters: <source>, <destination> copy source memory number, copy target memory number
format <NR1>, <NR1>, range 0 to 9 (copy source, copy target)
Example: MEM:COpy 0,1

:MEMory:DELeTe <setting_memory>

Description: Clears the specified setting memory contents to the initial values.
Parameters: <setting_memory> memory number, format <NR1>, range 0 to 9
Example: MEM:DEL 0

:MEMory:STATe <setting_memory>, <lock>**:MEMory:STATe?** <setting_memory>

Description: Sets/queries the setting memory modification status.
Parameters: <setting_memory> memory number: format <NR1>, range 0 to 9
<lock> modification status : format <NR1>, range 0/1
0: Free, 1: Lock
Settings example: MEM:STAT 0,0 Allows modifications to setting memory No.0
Response: <lock>
Query example: MEM:STAT? 3 Queries modification status of setting memory No.3
Response example: 0

:MEMory:TITLe <setting_memory>, <title>**:MEMory:TITLe?** <setting_memory>

Description: Sets/queries the setting memory title.
Parameters: <setting_memory> memory number: <NR1> 0 to 9
<title> title : <SRD> string of one-byte
18 characters or less

The allowed characters are the same as those allowed when inputting from the panel.

Lower case characters can be used during the setting but they will be converted to upper case characters.

Settings example: MEM:TIT 1, "TEST(1-2)"
Response: <title>
Query example: MEM:TIT? 1
Response example: "TEST(1-2)"

:SENSe:DATA:SPOT[:DATA]?

Description:	Outputs a spot measurement result according to the graph axis setting (measured value display format).
Parameters:	None
Response:	When: frequency, gain (dB), phase format <NR3>, <NR2>, <NR2> When: frequency, gain (linear), phase format <NR3>, <NR3>, <NR2> When: frequency, a (real part), b (imaginary part) format <NR3>, <NR3>, <NR3>
Response example:	SENS:DATA:SPOT? 12.345E+03,-118.62,45.54

:SENSe:DATA:SPOT:LIMit:GAIN:MAXimum <gain_upper_limit>**:SENSe:DATA:SPOT:LIMit:GAIN:MAXimum?**

Description:	Sets/queries the spot measurement gain evaluation upper limit.
Parameters:	<gain_upper_limit> Gain evaluation upper limit format <NR2>, range -199.99 to 199.99 [unit dB]
Settings example:	SENS:DATA:SPOT:LIM:GAIN:MAX 120.00
Response:	<gain_upper_limit>
Query example:	SENS:DATA:SPOT:LIM:GAIN:MAX?
Response example:	120.00

:SENSe:DATA:SPOT:LIMit:GAIN:MINimum <gain_lower_limit>

:SENSe:DATA:SPOT:LIMit:GAIN:MINimum?

Description: Sets/queries the spot measurement gain evaluation lower limit.
 Parameters: <gain_lower_limit> gain evaluation lower limit
 format <NR2>, range -199.99 to 199.99 [unit dB]
 Settings example: SENS:DATA:SPOT:LIM:GAIN:MIN -120.00
 Response: <gain_lower_limit>
 Query example: SENS:DATA:SPOT:LIM:GAIN:MIN?
 Response example: -120.00

:SENSe:DATA:SPOT:LIMit:PHASe:MAXimum <phase_upper_limit>

:SENSe:DATA:SPOT:LIMit:PHASe:MAXimum?

Description: Sets/queries the spot measurement phase evaluation upper limit.
 Parameters: <phase_upper_limit> phase evaluation upper limit
 format <NR2>, range -360.00 to 360.00 [unit deg]
 Settings example: SENS:DATA:SPOT:LIM:PHAS:MAX 120.00
 Response: <phase_upper_limit>
 Query example: SENS:DATA:SPOT:LIM:PHAS:MAX?
 Response example: 120.00

:SENSe:DATA:SPOT:LIMit:PHASe:MINimum <phase_lower_limit>

:SENSe:DATA:SPOT:LIMit:PHASe:MINimum?

Description: Sets/queries the spot measurement phase evaluation lower limit.
 Parameters: <phase_lower_limit> phase evaluation lower limit
 format <NR2>, range -360.00 to 360.00 [unit deg]
 Settings example: SENS:DATA:SPOT:LIM:PHAS:MIN -120.00
 Response: <phase_lower_limit>
 Query example: SENS:DATA:SPOT:LIM:PHAS:MIN?
 Response example: -120.00

SENSe:DATA:SPOT:LIMit:REPort?

Description: Queries the spot measurement evaluation result.
 Parameters: None
 Response: <gain_class>,<phase_class> gain evaluation result,
 phase evaluation result
 format <NR1>, <NR1>
 range -1/0/1
 -1: NG if less than the lower limit/ 0: GO /1: NG if more than
 the upper limit
 Query example: SENS:DATA:SPOT:LIM:REP?
 Response example: 0,0

:SENSe:DATA:SWEep[:DATA]?

Description:	Outputs all the sweep measurement results according to the graph axis (measured value display format). The data is output as multiple groups as follows according to data memory display settings.
	A: All the data in data memory A
	A/B: Data corresponding to A's measurement frequency points within the range of overlapping sweep frequencies between data memory A and B
	A&B: All of B data output after all of data A is output
	B: All the data in data memory B
Parameters:	None
Response:	When displaying frequency, gain dB, phase: format <NR3>, <NR2>, <NR2> When displaying frequency, gain (linear), phase: format <NR3>, <NR3>, <NR2> When displaying frequency, a (real part), b (imaginary part): format <NR3>, <NR3>, <NR3>
Query example:	SENS:DATA:SWE?
Response example:	12.345E+03,-118.62,45.54, . . . Outputs the data for all the measurement points delimited with comma (,)

:SENSe:DATA:SWEep:POINt?

Description:	Outputs measurement points for the sweep measurement results of the displayed data memory.
	A: Measurement points of data memory A
	A/B: Measurement points of memory A with respect to the frequency range common to data memories A and B
	A&B: Measurement points of data memory A followed by those of data memory B
	B: Measurement points of data memory B
Parameters:	None
Response:	When displaying A, A/B, B <NR1> When displaying A&B <NR1>, <NR1> For details of each value, refer to the description above.
Query example:	SENS:DATA:SWE:POIN?
Response example:	1000 When displaying A, A/B, B 1000, 1000 When displaying A&B

■ About frequency settings

It is possible to use k (kilo 10^3) and m (mili 10^{-3}) as suffix multipliers for the oscillator frequency as well as sweep measurement maximum and minimum frequency. It is also possible to use Hz as a suffix unit.

Ex. `FREQ:SWE:MAX 100kHz`

[[:SOURce]:FREQuency[:IMMediate] <freq_current>

[[:SOURce]:FREQuency[:IMMediate]?

Description: Sets/queries the oscillator frequency.
 Parameters: <freq_current> Oscillator frequency
 format <NR3>, range 0.10E-03 to 100.00E+03 [unit Hz]
 Settings example: `FREQ 1000`
 Response: <freq_current>
 Query example: `FREQ?`
 Response example: `1.0000E+03`

[[:SOURce]:SWEep:MEASure <measure_operation>

[[:SOURce]:SWEep:MEASure?

Description: Queries sweep/spot measurement operation instruction and status.
 Parameters: <measure_operation> Measurement operation
 format <CRD>, range STOP | HOLD | SPOT | UP | DOWN
 Settings example: `SWE:MEAS UP`
 Response: <measure_operation>
 Query example: `SWE:MEAS?`
 Response example: `UP`

[[:SOURce]:SWEep:MODE <operation_mode>

[[:SOURce]:SWEep:MODE?

Description: Sets/queries the sweep operation mode.
 Parameters: <operation_mode> operation mode, format <CRD>,
 range AUTO | MANUAL
 Settings example: `SWE:MODE AUTO`
 Response: <operation_mode>
 Query example: `SWE:MODE?`
 Response example: `AUTO`

[[:SOURce]:SWEep:SPACing[:TYPE] <freq_spacing>**[[:SOURce]:SWEep:SPACing[:TYPE]?**

Description: Sets/queries the sweep measurement frequency axis format.
Parameters: <freq_spacing> frequency axis format, format <CRD>, range LINear | LOGarithmic
Settings example: SWE:SPAC LIN
Response: <freq_spacing> The response is in short form (LIN | LOG).
Query example: SWE:SPAC?
Response example: LIN

[[:SOURce]:SWEep:SPACing:POINT <freq_points>**[[:SOURce]:SWEep:SPACing:POINT?**

Description: Sets/queries the sweep measurement frequency points (measurement points).
The measurement occurs a number of time specified frequency point at regular intervals on either linearly (Lin) or logarithmically (Log) axis between the minimum and the maximum frequency.
Parameters: <freq_points> frequency points, format <NR1>, range 3 to 1000
Settings example: SWE:SPAC:POIN 1000
Response: <freq_points>
Query example: SWE:SPAC:POIN?
Response example: 1000

[[:SOURce]:SWEep[:LEVEl]:MAXimum <freq_max>**[[:SOURce]:SWEep[:LEVEl]:MAXimum?**

Description: Sets/queries the sweep measurement maximum frequency.
Parameters: <freq_max> maximum frequency, format <NR3>, range 0.11E-03 to 100.00E+03 [unit Hz]
Settings example: SWE:MAX 100kHz
Response: <freq_max>
Query example: SWE:MAX?
Response example: 100.00E+03

[[:SOURce]:SWEep[:LEVEl]:MINimum <freq_min>**[[:SOURce]:SWEep[:LEVEl]:MINimum?**

Description: Sets/queries the sweep measurement minimum frequency.
Parameters: <freq_min> minimum frequency, format <NR3>, range 0.10E-3 to 99.999E+03 [unit Hz]
Settings example: SWE:MIN 0.0001
Response: <freq_min>
Query example: SWE:MIN?
Response example: 0.10E-03

[[:SOURce]:VOLTage:SLOW:ENABLE <slow_enable>**[[:SOURce]:VOLTage:SLOW:ENABLE?**

Description: Sets/queries the oscillator SLOW output status.
Parameters: <slow_enable> SLOW status
format <NR1>, range 0/1 0: Quick only 1: Slow enable
Settings example: VOLT:SLOW:ENAB 1
Response: <slow_enable>
Query example: VOLT:SLOW:ENAB?
Response example: 1

[[:SOURce]:VOLTage:SLOW[:STATe] <change_speed>**[[:SOURce]:VOLTage:SLOW[:STATe]?**

Description: Sets/queries the oscillator output variation speed.
Parameters: <change_speed> variation speed, format <bool>,
range OFF | 0 / ON | 1
OFF | 0 : Quick ON | 1 : Slow
Settings example: VOLT:SLOW ON
Response: <change_speed>, format <NR1>,
range 0/1 0: Quick 1: Slow
Query example: VOLT:SLOW?
Response example: 1

[[:SOURce]:VOLTage:OUTPut[:STATe] <output_state>**[[:SOURce]:VOLTage:OUTPut[:STATe]?**

Description: Sets/queries the oscillator ON/OFF.
Parameters: <output_state> output status, format <NR1>, range 0 | 1 | 2
0: AC/DC OFF, 1: AC OFF, 2: AC/DC ON
Each value corresponds to the ON AC/DC key on the panel.
Set to 1 puts AC to OFF and keeps DC in its previous state
Settings example: VOLT:OUTP 0
Response: <output_state> displays status according to each operation.
Query example: VOLT:OUTP?
Response example: 0

[[:SOURce]:VOLTage:OFFSet[:IMMediate] <dc_offset>**[[:SOURce]:VOLTage:OFFSet[:IMMediate]?**

Description: Sets/queries the oscillator DC bias.

Parameters: <dc_offset> DC bias, format <NR2>, range -10.00 to 10.00 [unit V]

Settings example: VOLT:OFFS 10.00

Response: <dc_offset>

Query example: VOLT:OFFS?

Response example: 10.00

[[:SOURce]:VOLTage[:LEVel][:IMMediate][:AMPLitude] <amplitude> [VRMS|VPK]**[[:SOURce]:VOLTage[:LEVel][:IMMediate][:AMPLitude]?**

Description: Sets/queries the oscillator AC amplitude.
The set value is interpreted as a value of the unit set in VOLTage:UNIT.
When a suffix is used for this value (VRMS | VPK), VOLTage:UNIT becomes irrelevant and the unit is interpreted as being the suffix.

Parameters: <amplitude> AC amplitude : <NR2> 0.000 to 7.07 [unit Vrms] | 0.000 to 10.00 [unit Vpk]

Settings example: VOLT 7.07 (Other examples) VOLT 10VPK, VOLT 1VRMS

Response: <amplitude>

Query example: VOLT?

Response example: 7.07

[[:SOURce]:VOLTage:UNIT <amplitude_unit>**[[:SOURce]:VOLTage:UNIT?**

Description: Sets/queries the oscillator AC amplitude display unit and response unit.

Parameters: <amplitude_unit> AC amplitude unit, format <CRD>, range VRMS | VPK

Settings example: VOLT:UNIT VRMS

Response: <amplitude_unit>

Query example: VOLT:UNIT?

Response example: VRMS

■ About the setting range to the status system 16 bit register

The MSB (most significant bit) of the status system 16 bit register is always set to 0. It is possible to set it to any value up to 65535 with a command but the target register will be set to have its MSB cleared to 0. Therefore, the response message to the query will have a value 32767 or less.

STATus:OPERation:CONDition?

Description: Queries operation condition register (OPCR).
 Parameters: None
 Response: Register contents, format <NR1>, range 0 to 32767
 Details . . .  "5.6.4 Operation Status"
 Query example: STAT:OPER:COND?
 Response example: 0

STATus:OPERation:ENABle <opee>

STATus:OPERation:ENABle?

Description: Sets/queries the operation event enable register (OPEE).
 Parameters: <opee> register contents, format <NR1>, range 0 to 65535
 Details . . .  "5.6.4 Operation Status"
 Settings example: STAT:OPER:ENAB 0
 Response: <opee>
 Query example: STAT:OPER:ENAB?
 Response example: 0

STATus:OPERation[:EVENT]?

Description: Queries the operation event register (OPER).
 Parameters: None
 Response: Register contents, format <NR1>, range 0 to 32767
 Details . . .  "5.6.4 Operation Status"
 Query example: STAT:OPER?
 Response example: 0

STATus:OPERation:NTRansition <transition_neg>**STATus:OPERation:NTRansition?****STATus:OPERation:PTRansition <transition_pos>****STATus:OPERation:PTRansition?**

Description: Sets/queries the operation transition filter.
Depending on the filter settings, each bit will be set to OPER as described below.

NTR	PTR	OPER
0	0	OPER is not set to 1 even if OPCR is modified
0	1	OPER is set to 1 if OPCR is modified from 0 to 1
1	0	OPER is set to 1 if OPCR is modified from 1 to 0
1	1	OPER is set to 1 if OPCR is modified

Parameters: <transition_neg> negative transition filter, format <NR1>, range 0 to 65535

<transition_pos> positive transition filter, format <NR1>, range 0 to 65535

Details . . .  "5.6.4 Operation Status"

Settings example: STAT:OPER:NTR 32767 Settings example: STAT:OPER:PTR 0

Response: <transition_neg> Response: <transition_pos>

Query example: STAT:OPER:NTR? Query example: STAT:OPER:PTR?

Response example: 32767 Response example: 0

STATus:OVERload:ENABLE <ovee>**STATus:OVERload:ENABLE?**

Description: Sets/queries the overload event enable register (OVEE).

Parameters: <ovee> register contents, format <NR1>, range 0 to 65535

Settings example: STAT:OVER:ENAB 0

Response: <ovee>

Query example: STAT:OVER:ENAB?

Response example: 0

STATus:OVERload [:EVENT]?

Description: Queries the overload event register (OVER).

Parameters: None

Response: register contents, format <NR1>, range 0 to 32767

Details . . .  "5.6.5 Overload Status"

Query example: STAT:OVER?

Response example: 0

SYSTem:ERRor?

Description:	Queries the error status
Parameters:	None
Response:	Error number, error message Error number: format <NR1>, range -32768 to +32767 Error message: format <SRD> Details . . .  "6.1.3 Remote Control Errors"
Query example:	SYST:ERR?
Response example:	0,"No error"

SYSTem:OVERload:RELease

Description:	Releases the error just like RESET ERROR key from the front panel. Example of released error <ul style="list-style-type: none">• Input signal exceeds measurement possible voltage range• User set excessive input detection level is exceeded• Output overload
Parameters:	None
Example:	SYST:OVER:REL

5.6 Status System

5.6.1 Status System Overview

The status system for FRA5022 is shown on figure 5-2.

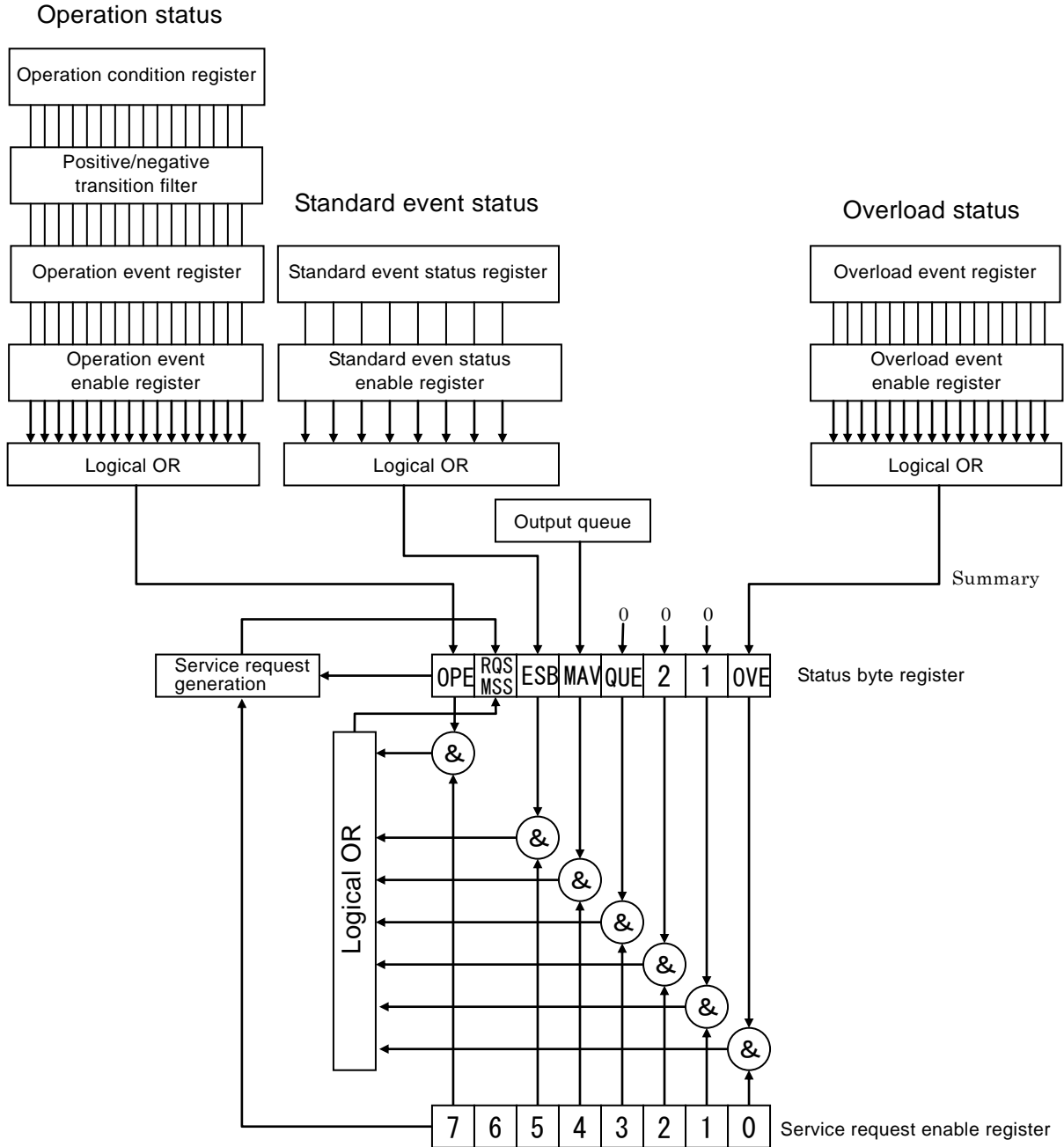

Figure 5-2 Status system

5.6.2 Status Byte

The status byte register definitions are shown in table 5-3. Each status byte register bit becomes valid when the corresponding service request enable register bit is set to 1. When at least one such bit is set to 1, a service request is generated. It is possible to readout the status byte with a serial poll or a *STB? query.

Table 5-3 Status byte register definitions

Bit	Weight	Condition to set to 1	Condition to set to 0	
OPE	7	128	When any valid bit of the operation event register is set to 1.	When all of the valid bits of the operation event register are set to 0.
RQS / MSS	6	64	When SRQ is sent	RQS: When SRQ is cleared by a serial poll, etc. MSS: When all of the source summary bits are cleared to 0.
ESB	5	32	When any valid bit of the standard event status register is set to 1.	When all the valid bits of the standard event status register are set to 0.
MAV	4	16	When the response to the query is ready to be output.	When all of the responses have been output and there remains none to be output.
QUE	3	8	—	Always at 0 (unused)
—	2	4	—	Always at 0 (unused)
—	1	2	—	Always at 0 (unused)
OVE	0	1	When any valid bit of the overload event register is set to 1.	When all of the valid bits of the overload event register are set to 0.

■ About verifying status when querying

Normally, once a query command is sent, all you have to do is wait for the response message. There is no need to check the MAV bit of the status byte.

■ Related commands/queries

*STB?

Queries the contents of the status byte.

Bit 6 of the response is MSS (Master Summary Status).

Bit 6 of the serial poll is RQS (Request Service).

*SRE / *SRE?

Sets/queries the service request enable register.

Set to 0 to clear the enable register to 0.

Cannot be cleared by any other command.

Cleared to 0 upon powering on.

The parameter value of the setting message or response message to each register is the sum of the weight of all the bits having 1 as the value.

5.6.3 Standard Event Status

The standard event status structure is shown on figure 5-3. Details about status are shown in table 5-4. When the standard event status enable register bits are set to 1, the corresponding standard event status register bits become valid. When at least one such bit is set to 1, the status bit register ESB bit is set to 1.

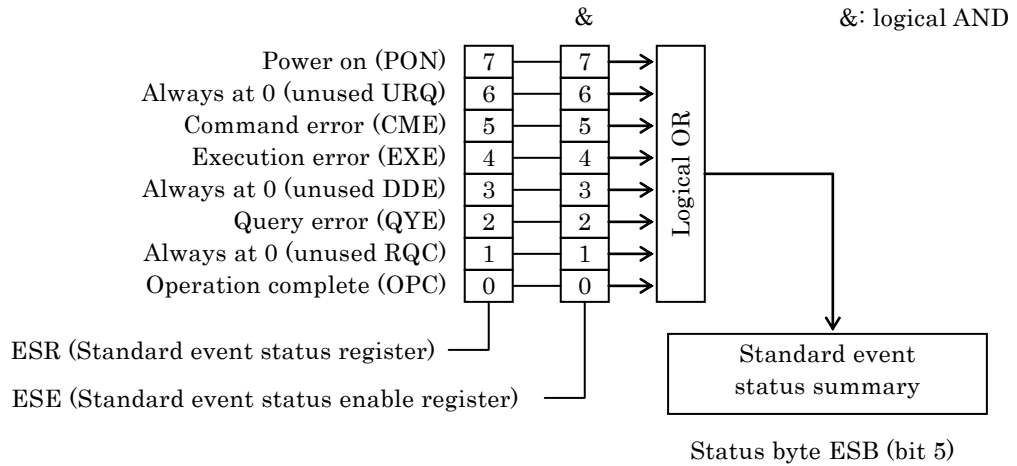

Figure 5-3 Standard event status structure

Table 5-4 Standard event status register contents

Bit	Weight	Contents
PON	7	128 Power on Set to 1 when the power is on. If set to 0 by a register readout, remains at 0 until the power is turned on again.
URQ	6	64 User request Always at 0 (unused)
CME	5	32 Command error Set to 1 when there is a syntax error in program code.
EXE	4	16 Execution error Set to 1 when parameters are set beyond possible range values or when settings are contradictory.
DDE	3	8 Device dependent error Always at 0 (unused)
QYE	2	4 Query error Set to 1 when a readout has been attempted on an empty response message output buffer or when the response message output buffer data has been lost.
RQC	1	2 Request control Always at 0 (unused)
OPC	0	1 Operation complete Set to 1 when the all the overlapped command process have been completed.

■ Related commands / queries

*ESR?

Queries the contents of the standard event status register.
Cleared to 0 upon query. Can be cleared also by *CLS command.
Cleared to 0 upon powering on. However the PON bit is set to 1.

*ESE / *ESE?

Sets/queries the standard event status enable register.
Set to 0 to clear the enable register to 0.
Cannot be cleared by any other command.
Cleared to 0 upon powering on.

The parameter value of the setting message or response message to each register is the sum of the weight of all the bits having 1 as the value.

5.6.4 Operation Status

The operation status structure is shown on figure 5-4.

As can be seen on table 5-5, the operation condition register displays FRA5022's status. When a positive transition filter register bit is set to 1, the corresponding state changes from 0 to 1 and the operation event register bit is set to 1. When a negative transition filter register bit is set to 1, and the state has changed from 1 to 0, the operation event register bit is set to 1. It is possible to detect both modifications: 0→1, 1→0.

When the operation event enable register bits are set to 1, the corresponding operation event register bits become valid. When at least one such bit is set to 1, the status byte OPE bit is set to 1.

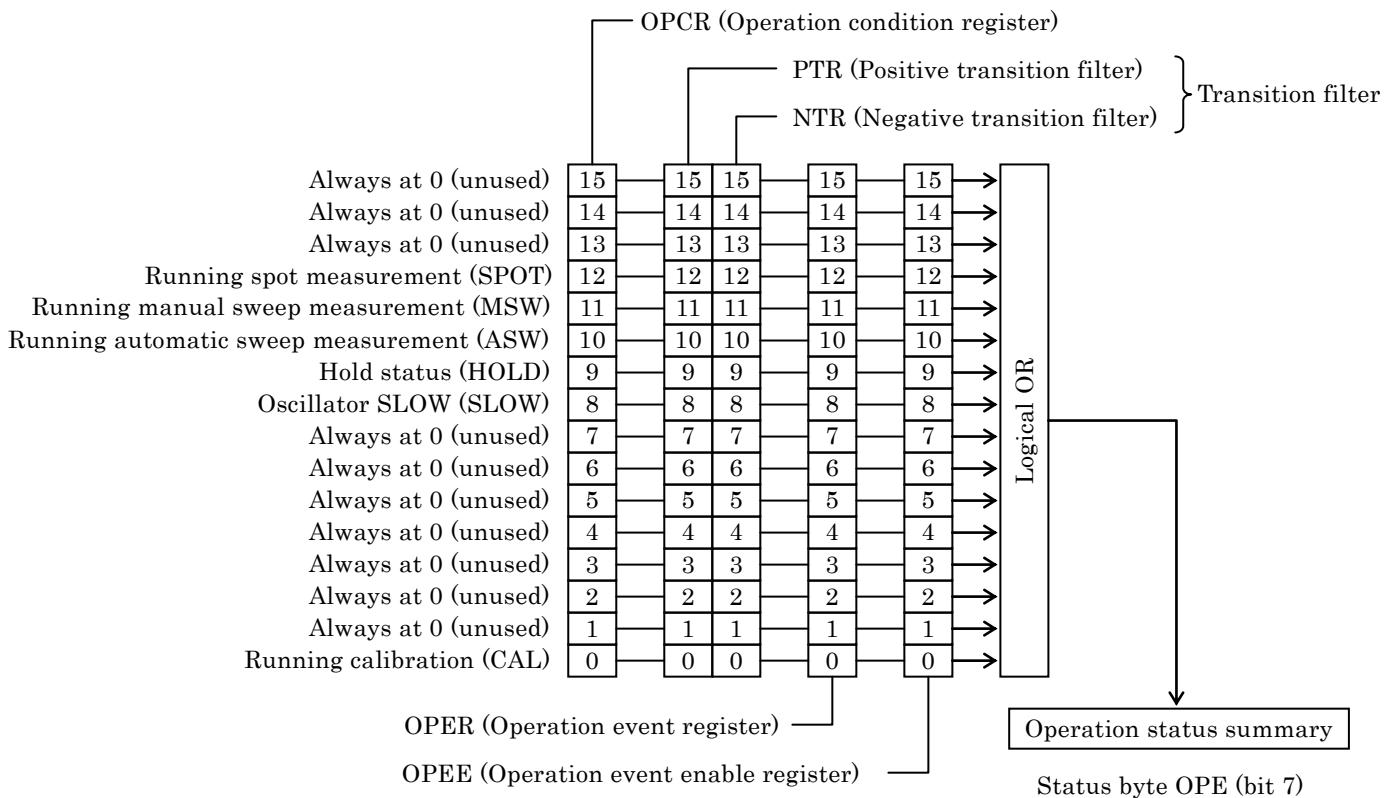

Figure 5-4 Operation status structure

Table 5-5 Operation condition register contents

Bit	Weight	Contents (when standard status 1)
SPOT	12	4096 During spot measurement Single: At each measurement, set to 1 when the measurement starts, and cleared to 0 when the measurement ends. Repeat: Remains 1 during a repeat measurement. Not cleared to 0 at each measurement.
MSW	11	2048 In manual sweep measurement: running measurement at one point
ASW	10	1024 Running automatic sweep measurement
HOLD	9	512 Hold state
SLOW	8	256 Changing output voltage SLOW
CAL	0	1 Running self calibration
Other	—	— Always at 0 (unused)

■ Related commands / queries

STATus:OPERation:CONDition?

Queries the operation condition register contents.

The condition register content is not cleared to 0 even if queried.

Always indicates the status of FRA5022.

STATus:OPERation:NTRansition / STATus:OPERation:NTRansition?

Sets/queries the negative transition filter register.

STATus:OPERation:PTRansition / STATus:OPERation:PTRansition?

Sets/queries the positive transition filter register.

Set to 0 to clear these filter registers to 0.

Cannot be cleared by any other command.

Cleared to 0 upon powering on.

STATus:OPERation[:EVENT]?

Queries operation event register.

The event register is cleared to 0 if queried.

The event register can also be cleared with a *CLS command.

Cleared to 0 upon powering on.

STATus:OPERation:ENABLE / STATus:OPERation:ENABLE?

Sets/queries the operation event enable register.

Set to 0 to clear the enable register to 0.

Cannot be cleared by any other command.

Cleared to 0 upon powering on.

A parameter of each register setting message or response message takes a value that adds up the weight of all bits set to 1.

5.6.5 Overload Status

The overload status structure is shown on figure 5-5.

As can be seen on table 5-6, the overload event register displays FRA5022's input/output status.

When the overload event enable register bits are set to 1, the corresponding overload event register bits become valid. When at least one such bit is set to 1, the status byte OVE bit is set to 1.

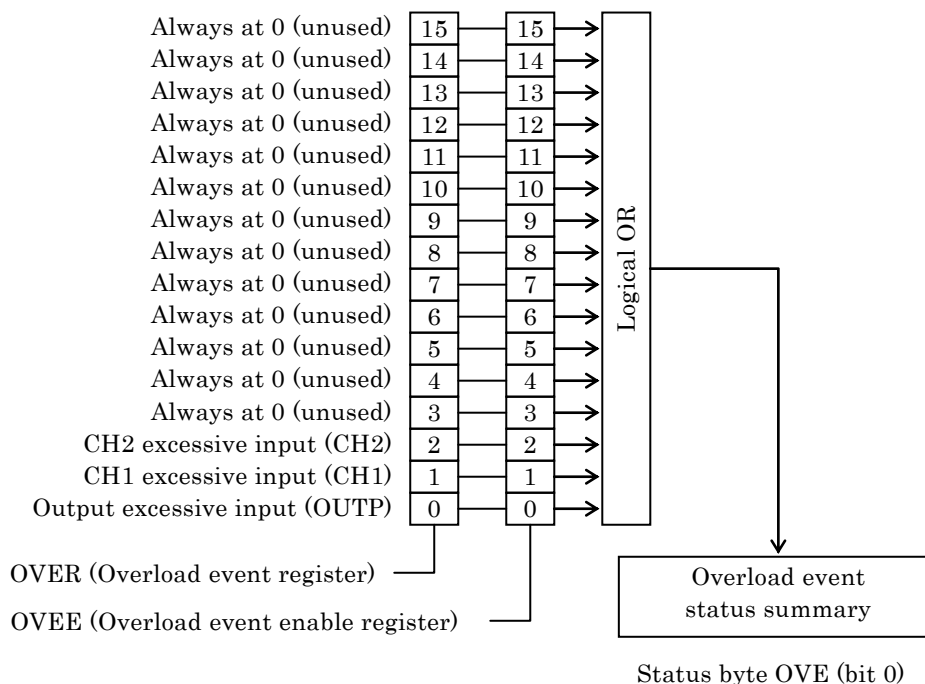

Figure 5-5 Overload status structure

Table 5-6 Overload event register contents

Bit	Weight	Contents (when standard status 1)	
CH2	2	4	Excessive input detected in CH2 (OVER lamp lit)
CH1	1	2	Excessive input detected in CH1 (OVER lamp lit)
OUTP	0	1	The oscillator output current has largely exceeded the allowable range
Other	—	—	Always at 0 (unused)

■ Related commands / queries

STATus:OVERload:ENABle / STATus:OVERload:ENABle?

Sets/queries the overload event enable register.

Set to 0 to clear the enable register to 0.

Cannot be cleared by any other commnad.

Cleared to 0 upon powering on.

STATus:OVERload [:EVENTt]?

Queries overload event register.

An overload event can not be cleared to 0 only if the status that caused its generation has been released.

The event register is cleared to 0 if queried.

The event register can also be cleared with a *CLS command.

Cleared to 0 upon powering on.

A parameter of each register setting message or response message takes a value that adds up the weight of all bits set to 1.

5.7 Programming Cautions

■ Cautions when sending commands

When you send a command, line feed LF (0AH) is required at the end of the sent string as the program message terminator. A command sent without LF may not work properly. Normally, commands sent from the controller computer are automatically followed by LF or END. However, some drivers may not work properly unless you specify separately that LF or END should follow the command. In some cases, line feed may be referred to as new line, but they have the same binary code.

6. TROUBLESHOOTING

- 6.1 Error Messages 6-2
 - 6.1.1 Errors at Power-On 6-2
 - 6.1.2 Error During Panel Operation 6-3
 - 6.1.3 Remote Control Errors 6-3
- 6.2 When Fault Symptoms are Observed 6-4

6.1 Error Messages

Self-diagnosis is performed when the power is turned on. If an error is detected, an error message is displayed in the lower part of the start screen. Similarly, when improper values are being set via the remote control interface, an error message is displayed. Error messages are also displayed when your operation via the front panel has some restrictions.

Error messages and their causes are described below, together with required actions. Some other messages may be displayed depending on the situation.

6.1.1 Errors at Power-On

Error messages	Cause	Required action
ROM ERROR	Internal ROM error	Turn the power off, wait for at least 3 seconds and turn the power on again. If the error message persists after turning the power on several times, it will be necessary to make repairs. Contact NF Corporation or one of our representatives.
SDRAM ERROR	Internal SDRAM error	
BACKUP MEMORY ERROR	Battery backup contents are broken. <ul style="list-style-type: none"> • Backup battery is empty • Backup memory fault • Temporary internal data error due to power-off, etc. while operating on the memory 	
ANALYZER ERROR	Analyzer malfunction	
CALIBRATION ERROR	Self calibration error Problem with the signal measurement system in the oscillator or the analyzer.	

When an error message is displayed, check "Installation Conditions" in "2.2 Installation" and verify that all the operation conditions are met.

When ROM or SDRAM error is detected, further operation is not possible.

When battery backup contents are broken, the device starts after settings and measurement data memory are initialized. When that happens, the line after the above error message indicates which memory category has been initialized.

STn: Settings memory n = 0..9

NS: Settings not indicated on the left

SA: Data memory A for sweep measurements

SB: Data memory B for sweep measurements

PA: Data memory A for spot measurements

PB: Data memory B for spot measurements

When signal system error during analyzer self check or self calibration is found, error messages are displayed and further operation is not possible.

6.1.2 Error During Panel Operation

Main error messages displayed during panel operation are as bellow.

Error messages	Error cause
Execution error	Error when executing the instruction command (no detailed classification)
Data out of range	The set value is beyond the possible range
Invalid param (max<=min)	Max and min have been reversed when setting a graph display range, etc.
OSC AC+DC > +/-10.5V	The oscillator output voltage peak value is too high. A normal signal cannot be output
OSC ac output = off	A measurement was going to be executed with AC amplitude set to 0
OSC is on	Self calibration cannot be executed because the oscillator's output is on
Parameter is locked	A setting was going to be modified while the setup item was locked. Free the setup item and correct the setting.
OSC Overload	The oscillator output is in overload state

6.1.3 Remote Control Errors

Error number	Error messages	Error cause
0	"No error"	No error
	<Syntax error>	
-100	"Command error"	Illegal command input (no detailed classification)
-101	"Invalid character"	An invalid character was included in the command
-102	"Syntax error"	Input of undefined command or parameter
	<Execution error>	
-200	"Execution error"	Error when executing a command (no detailed classification)
-222	"Data out of range"	The set command parameter is beyond the possible range
-350	"Too many errors"	Error queue overflow, new errors will not be maintained
	<FRA5022 specific error >	
-370	"Invalid parameter (max<=min)"	Max and min have been reversed when setting a graph display range, etc.
-371	"OSC ad+dc > +/- 10.5V"	The oscillator output voltage peak value is too high. A normal signal cannot be output
-372	"OSC ac output = off"	A measurement was going to be executed with AC amplitude set to 0
-373	"OSC is on"	Self calibration cannot be executed because the oscillator's output is on
-374	"Buffer overflow"	Input buffer (about 4,000 characters) or output buffer (about 80,000 characters) overflow.
-375	"Parameter is locked"	A setting was going to be modified while the setup item was locked.
-376	"OSC Overload"	The oscillator output is in overload state

6.2 When Fault Symptoms are Observed

If you found a malfunction, try the following actions. If the problem persists, contact NF Corporation or one of our representatives.

Contents	Possible cause	Solution
Power supply cannot be turned on	The power supply used is not in conformance with the specified ratings	Use a power supply in conformance with the specified ratings. Firmly insert the power cord.
Self calibration error	The operation is not normal due to external noise, etc.	Power off and then on. Relocate the device to a better environment.
Panel operation does not work	The device is in the remote control state.	Press the BS/LOCAL key to reset the device to the LOCAL control state.
	Keys have been deteriorated	Contact NF Corporation or one of our representatives for repair.
Impossible to set	Setting memory is protected (Lock)	Clear protection (select "Free") on the menu screen.
AC amplitude is wrong	The ON AC/DC key is not pressed	Press the OSCILLATOR ON AC/DC key. Setting the value only will not modify the output.
	The units selected (Vrms or Vpeak) are incorrect.	Select Vrms and Vpeak correctly using the "+/-pk/rms" keys.
	The load impedance is low; the signal voltage is divided between the 50 Ω output impedance and the load (impedance).	Increase the voltage according to the load impedance.
The measured values vary largely.	The oscillator is off	Press the OSCILLATOR ON AC/DC key. Setting the value only will not modify the output.
	The drive signal level is smaller than the set value	
	Noise is too big or the signal is too small	Raise the AC amplitude or lengthen the integration time.
	The connecting cable to the oscillator is damaged	Check the signal wave on an oscilloscope or the voltage monitor display in the spot measurement screen.
The measured value is wrong (different from the estimate)	Data memory display is set to A/B, or to B	Change the data memory display to A via the menu screen. The latest measurement data is stored in the data memory A.
	The measurement mode selected (CH2/OSC or CH2/CH1) is incorrect.	Select the reference from either of OSC or CH1 connector input depending on the actual connection.
	The connecting cables to CH1 and CH2 are damaged.	Check the signal wave on an oscilloscope or the voltage monitor display in the spot measurement screen.
The device does not operate as described in the Instruction Manual	Total initialization of the settings has not been executed	Most of the descriptions contained in this manual presuppose that the settings have already been initialized. Perform total initialization.
Remote control does not work	GPIB/USB selection is invalid.	Select either of GPIB or USB via the system menu screen.

7. MAINTENANCE

7.1 Introduction.....	7-2
7.2 Daily Maintenance.....	7-2
7.3 Storage, Repacking, and Transportation	7-2
7.4 Checking Version Number	7-3
7.5 Checking Isolation.....	7-3
7.6 Checking Oscillator Output Wave Form	7-3
7.7 Performance Testing.....	7-3
7.7.1 Frequency Accuracy Test.....	7-4
7.7.2 Oscillator AC Amplitude Accuracy Test	7-4
7.7.3 Oscillator DC Bias Accuracy Test	7-4
7.7.4 Ratio Accuracy Test.....	7-5
7.7.5 IMRR Test	7-6
7.7.6 Dynamic Range Test.....	7-6
7.8 Calibration	7-7

7.1 Introduction

The following maintenance is essential for using the device under the best condition.

- Operation inspection: Check if the device operates properly.
- Performance testing: Check if the device respects the rated values.
- Adjustment, calibration: If the rated values are not satisfying, NF Corporation will make the necessary adjustment or calibration to restore performance.
- Damage repairs: When performance cannot be restored by the adjustment or calibration, NF Corporation will identify the cause and location of the damage and will execute repairs.

This instruction manual describes how to easily proceed with a performance testing. For more accurate inspections, adjustments, calibration or repairs, contact NF Corporation or one of our representatives.

A performance testing requires the following measuring instruments.

- Oscilloscope: Frequency band: 10MHz or more
- Frequency counter: Accuracy: within $\pm 5 \times 10^{-6}$
- AC voltmeter: Accuracy: within $\pm 0.2\%$, True RMS
Frequency band: 100kHz or more
- DC voltmeter: Accuracy: within $\pm 0.1\%$
- Resistance meter (tester): Measurement range: 10M Ω or more

7.2 Daily Maintenance

Install FRA5022 in a location that fills the installation requirements.

Installation conditions  "Installation Conditions" in "2.2 Installation"

When the case/panel surface needs cleaning, wipe with a soft cloth. To remove persistent contamination, wipe with a soft cloth soaked with neutral detergent and wrung out.

Do not use any organic solvents like thinner or benzene, or any chemical cleaning cloth, as they may cause the surface finish to deteriorate, tarnish, or come off.

7.3 Storage, Repacking, and Transportation

Store FRA5022 in a location that fills the installation requirements.

Installation conditions  "2.2.2 Installation Conditions"

When repacking is necessary, for transportation for example, use a case that is of sufficient size and strength, use filling that can stand the weight of the device and make sure the device is sufficiently protected.

Make sure the device will not stand shocks during transportation.

7.4 Checking Version Number

The version number of your FRA5022 is displayed after power-on for a few seconds at the center of the screen under the model name. The version number can be retrieved by using the query “*IDN?”.

About commands  “5. REMOTE CONTROL”

7.5 Checking Isolation

In FRA50022, each of the oscillator output or analyzer inputs are separately isolated from the case.

By using a resistance meter (including tester or multimeter, etc), check that the resistance between each of the external conductors of BNC connectors on the front panel and the grounding terminal on the left bottom of the front panel is 10M Ω or more. Also check the resistance between the BNC connectors in the same manner.

7.6 Checking Oscillator Output Wave Form

Connection: OUTPUT OSCILLATOR \rightarrow oscilloscope input (input impedance 1M Ω)

Settings: After initializing the settings, press the ON AC/DC key with Frequency 1kHz and Amplitude 7.07Vrms.

Measurement: Measure the oscilloscope wave form.

Evaluation: Correct if it is a 20Vp-p sine wave. Check that there is no distortion or noise.

7.7 Performance Testing

Performance testing is conducted as part of preventive maintenance to prevent performance degradation of the FRA5022.

FRA5022 performance testing is also conducted as part of acceptance inspection, periodic inspection, performance verification after repair, and so forth.

If the result of a performance testing does not meet the specifications, calibration or repair is required. Contact NF Corporation or one of our representatives.

The performance testing should be conducted in the following conditions.

- Power voltage: 100 to 230V \pm 10% (250V or less)
- Ambient temperature: 23 \pm 5 $^{\circ}$ C
- Ambient humidity: 20 to 70%RH, non-condensing
- Warm up: 30 min or more

Take the following precautions when you conduct a performance testing.

- When the use of a coaxial cable is required, use a cable with the following characteristics: characteristic impedance 50 Ω , thickness RG-58A/U or more, length 1m or less. BNC connectors at both ends.
- When 50 Ω termination is specified, set the connected measuring instrument input to 50 Ω . For a measuring instrument that cannot be set to 50 Ω , install a feed through terminator of 50 Ω to the measuring instrument input to terminate it.
- The setting options for each test item are the items that can be changed after the device is initialized and powered on. First, perform “INITIALIZE all” (total initialization) via the system menu screen.

 “3.5.4 System Menu Screen”

7.7.1 Frequency Accuracy Test

Connection: OUTPUT OSCILLATOR → Frequency counter input

Settings: After initializing the settings, press the ON AC/DC key with Frequency 100kHz and Amplitude 1Vrms/open.

Measurement: Measure the frequency with the frequency counter.

Evaluation: Correct if ± 50ppm (99.9950kHz to 100.0050kHz)

7.7.2 Oscillator AC Amplitude Accuracy Test

Connection: OUTPUT OSCILLATOR → AC voltmeter input

Settings: After initialization the settings, set frequency and AC amplitude Vrms/open according to the following table.

Press the ON AC/DC key to reflect the changes in output.

Measurement: Measure the output voltage with the AC voltmeter.

Evaluation: Correct if within the bellow specification range.

AC amplitude setting	Specification (1kHz) ±(2% of set value +7mVrms)	Specification (100kHz) ±(4% of set value +21mVrms)
7.07Vrms	6.9216 - 7.2184 Vrms	6.7662 - 7.3738 Vrms
3.0Vrms	2.933 - 3.067 Vrms	2.859 - 3.141 Vrms
1.5Vrms	1.463 - 1.537 Vrms	1.419 - 1.581 Vrms
0.7Vrms	0.679 - 0.721 Vrms	0.651 - 0.749 Vrms
0.3Vrms	0.287 - 0.313 Vrms	0.267 - 0.333 Vrms
0.15Vrms	0.140 - 0.160 Vrms	0.123 - 0.177 Vrms
0Vrms	0.000 - 0.007 Vrms	0.000 - 0.021 Vrms

7.7.3 Oscillator DC Bias Accuracy Test

Connection: OUTPUT OSCILLATOR → DC voltmeter input

Settings: After initialization the settings, set AC amplitude to 0 Vrms and DC bias (V/open) according to the following table.

Press the ON AC/DC key to reflect the changes in output.

Measurement: Measure the voltage with the DC voltmeter.

Evaluation: Correct if within the bellow specification range.

DC bias setting	SPECIFICATIONS ±(0.5% of the set absolute value +30mV)
+10V	+9.920V - +10.080V
+5V	+4.945V - +5.055V
+1V	+0.965V - +1.035V
0V	-0.030V - +0.030V
-1V	-1.035V - -0.965V
-5V	-5.055V - -4.945V
-10V	-10.080V - -9.920V

7.7.4 Ratio Accuracy Test

Connection: OUTPUT OSCILLATOR → INPUT CH1, CH2 parallel

Separate the oscillator output in two by using a T shape divider and connect each end to the analyzer's CH1 and CH2.

Use a BNC-BNC coaxial cable with a response impedance of $50\ \Omega$ and a length of 1m.

Settings: After initialization the settings,

Minimum frequency: 10Hz, Maximum frequency: 100kHz, Frequency points: 100

Integration cycle: 1, Integration time: 0.10s

AC amplitude: 7.07, 1, 100m, 10m Vrms/open

After each modification of amplitude press the ON AC/DC key to reflect the changes in output.

Measurement: For each AC amplitude, press the DOWN or UP key and execute a sweep measurement.

Evaluation: Correct if within the following range.

With Frequency $\leq 20\text{kHz}$ Gain $0 \pm 0.05\text{dB}$ / Phase $0 \pm 0.3^\circ$

With Frequency $> 20\text{kHz}$ Gain $0 \pm 0.15\text{dB}$ / Phase $0 \pm 1^\circ$

7.7.5 IMRR Test

Connection: OUTPUT OSCILLATOR

- INPUT CH2 and CH1 core conductor and outer conductor together (when testing CH1)
- INPUT CH1 and CH2 core conductor and outer conductor together (when testing CH2)

Separate the oscillator output in two by using a T shape divider.

Short circuit the input connector core conductor and external conductor of the channel under test and send a signal between the case and the input connector. Input a drive signal to the other channels.

Settings: After initialization the settings, Frequency: 60Hz, Integration time: 10s
AC amplitude 7.07Vrms, press the ON AC/DC key to reflect the changes in output.

Measurement: Press the SPOT key and execute a spot measurement of CH2/CH1.

Evaluation: Correct if tested CH1 gain > 120dB, tested CH2 gain < -120dB.

To measure a very small signal in IMRR or dynamic range tests, it is necessary to repeat the measurement a few times until the value stabilizes. This behavior is correct.

Example of CH1 IMRR test

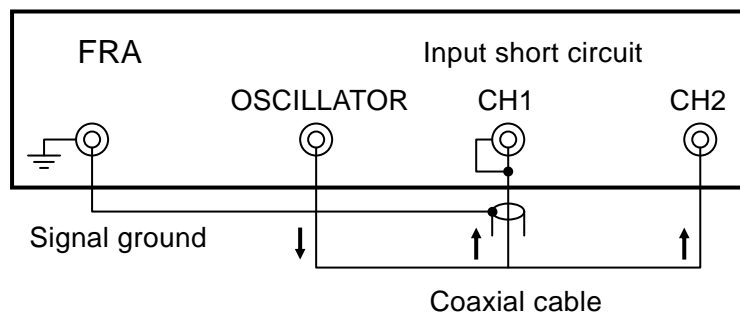

7.7.6 Dynamic Range Test

Connection: OUTPUT OSCILLATOR → INPUT CH2 CH1 input is short circuited (when testing CH1)

OUTPUT OSCILLATOR → INPUT CH1 CH2 input is short circuited (when testing CH2)

Settings: After initialization the settings,

Minimum frequency: 10Hz, Maximum frequency: 100kHz, Frequency points: 40, integration time 10s, AC amplitude 7.07Vrms, press the ON AC/DC key to reflect the changes in output.

Measurement: Press the DOWN or UP key and execute a sweep measurement of CH2/CH1. When there is a lot of electromagnetic interferences a set frequency may not fit the specified range. Keep the noise source at a distance and conduct the tests.

Evaluation: Correct if tested CH1 gain > 120dB, tested CH2 gain < -120dB.

Example of CH1 dynamic range test

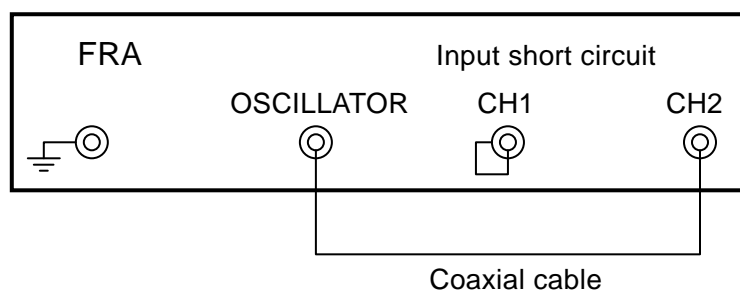

7.8 Calibration

If the performance test does not produce satisfying results, NF Corporation will make the necessary adjustment or calibration to restore performance.

If calibration is necessary, contact NF Corporation or one of our representatives.

You will be liable for the costs of adjustment and calibration outside the warranty period.

8. SPECIFICATIONS

8.1 Oscillator.....	8-2
8.2 Analyzer Input	8-3
8.3 Analysis Processor	8-3
8.4 Measurement Processing	8-4
8.5 Display Part	8-5
8.6 Settings Memory.....	8-5
8.7 Remote Control Interface.....	8-5
8.8 General Information.....	8-6

Values without accuracy (range) are typical values.

8.1 Oscillator

- Output waveform: Sine wave
- Frequency
 - Setting range: 0.1mHz to 100kHz
 - Setting resolution: 5 digits, or 0.01mHz whichever is the largest.
 - Accuracy: $\pm 50\text{ppm}$
- AC Amplitude
 - It is possible to set AC amplitude in V_{rms} or in V_{peak} .
 - Setting range: 0 to 7.07 V_{rms} or 0 to 10 V_{peak}
 - Setting resolution:
 - 0.01 V_{rms} (amplitude $\geq 1V_{\text{rms}}$), 0.001 V_{rms} (amplitude $< 1V_{\text{rms}}$)
 - Or 0.01 V_{peak} (amplitude $\geq 1V_{\text{peak}}$), 0.001 V_{peak} (amplitude $< 1V_{\text{peak}}$)
 - Accuracy: $\pm (2\% \text{ of set value} + 7\text{m}V_{\text{rms}}$ or $10\text{m}V_{\text{peak}})$
 - When $10\text{Hz} \leq \text{frequency} \leq 20\text{kHz}$
 - $\pm (4\% \text{ of set value} + 21\text{m}V_{\text{rms}}$ or $30\text{m}V_{\text{peak}})$
 - When $20\text{kHz} < \text{frequency}$
 - In either cases, the output is open and there is no output change rate limit
 - V_{peak} is converted from V_{rms} measured on a sine wave
- DC bias
 - Setting range: -10V to +10V
 - Setting resolution: 0.01V
 - Accuracy: $\pm (0.5\% \text{ of the set absolute value} + 30\text{mV} + 2\% \text{ of AC amplitude } V_{\text{peak}})$
 - When output is open
- Max output (AC + DC)
 - Voltage: $\pm 10\text{V}$ (when output open)
 - Current: $\pm 100\text{mA}$
- Distortion factor: 0.3% or less ($10\text{Hz} \leq \text{frequency} \leq 10\text{kHz}$)
 - 1% or less ($10\text{kHz} < \text{frequency} \leq 100\text{kHz}$)
 - With amplitude setting 10 V_{peak} , DC bias 0V, load 50 Ω , band 500kHz
- Output impedance: 50 Ω , unbalanced
- Output control: AC/DC both on, AC/DC both off, AC only off
 - It is possible to limit the output variation rate to output both AC/DC with a slow variation
- Isolation
 - Insulation voltage: 42Vpk or 30 V_{rms} , DC to 100kHz continuously
 - From/to one another among oscillator output (signal, ground), analyzer channel input (signal, ground), and the case
 - Case-to-oscillator electrostatic capacitance: 250pF or less

8.2 Analyzer Input

- Channel number: 2
- Input impedance: $1\text{M}\Omega$, parallel 60pF
- Frequency range: 0.1MHz to 100kHz (same as oscillator)
- Input voltage
 - Measurement range: $\pm 10\text{V}$
 - Maximum non-destructive input: $\pm 24\text{V}$
- Excessive input detection level Detected by fundamental wave amplitude
 - Setting range: 0.01 to 19.99Vrms
 - Setting resolution: 0.01Vrms
 - Processing method: OVER lamp on / warning sound generation / sweep abort / oscillator off
- Measurement range: Automatic switching
- IMRR: 120dB or more, with 1Hz to 60Hz , signal source impedance $\leq 1\Omega$
 - Attenuation when signal ground potential variations (vs case) interfere with the signal
- Dynamic range: 120dB or more
 - When 1Hz to 100kHz , integration time $\geq 10\text{s}$ and ≥ 100 cycles
 - Signal magnitude ratio when the one channel is at 10Vpeak and the other channel is terminated with a signal source impedance 1Ω or less
- Isolation
 - Insulation voltage: 42Vpk or 30Vrms , DC to 100kHz continuously
 - Analyzer channel input (signal, ground), oscillator output (signal, ground), to/from the case
 - Case-to-analyzer electrostatic capacitance: 300pF or less

8.3 Analysis Processor

- Measurement mode: CH2/CH1, CH2/OSC
- Integration time The smallest cycle equal or greater than the longer of the following.
 - Cycle setting range: 1 to 999 cycles
 - Time setting range: 0.01 to 999.99s
- Ratio accuracy: Gain $\pm 0.05\text{dB}$ ($\pm 0.5\%$) / Phase $\pm 0.3\text{deg}$ When 0.1Hz to 20kHz
 Gain $\pm 0.15\text{dB}$ ($\pm 1.5\%$) / Phase $\pm 1\text{deg}$ Outside the above ranges
 When measurement mode CH2/CH1, input signal level $\geq 10\text{mVrms}$, after 30min warm up, and after self calibration is completed

8.4 Measurement Processing

- Measurement mode

Sweep: Measures while sweeping between the minimum and maximum frequencies and displays as graph.

Spot: Measures at a specified frequency, displays the results as numerical values.

Scan: Measures at up to ten frequency points by shifting sequentially among the spot settings automatically or manually.

- Sweep control

Frequency scale: Linear/Log

Sweep operation: UP (min → max)

DOWN (max → min)

HOLD (holds sweep)

STOP (stops measurement)

Automatic/Manual switching

Automatic: moves automatically to the next frequency point

Manual: moves manually one point at a time to the next frequency point

- Delay time

Delay between the point when the user changes the frequency and the point when the actual signal measurement starts.

Setting range: 0.00 to 999.99s

8.8 General Information

- Power for 5055: The AUX connectors on the rear panel provide +24V/-24V
- Memory backup: Even with the power off settings and measured data are conserved
Battery life: 3 years (when exhausted, non-free exchange)
- Power Supply
 - Voltage range: AC100V to 230V \pm 10%, but 250V or less
 - Frequency range: 50/60Hz \pm 2Hz
 - Power consumption: 55VA max
 - Over voltage category: II
- Environmental conditions
 - Altitude: 2000m or less
 - Temperature/humidity range
 - Performance guarantee
 - Temperature: +5 to +35°C
 - Humidity: 5 to 85%RH Absolute humidity 1 to 25 g/m³, non-condensing.
 - Operation
 - Temperature: 0 to +40°C
 - Humidity: 5 to 85%RH Absolute humidity 1 to 25 g/m³, non-condensing.
 - Storage
 - Temperature: -10 to +50°C
 - Humidity: 5 to 95%RH Absolute humidity 1 to 29 g/m³, non-condensing.

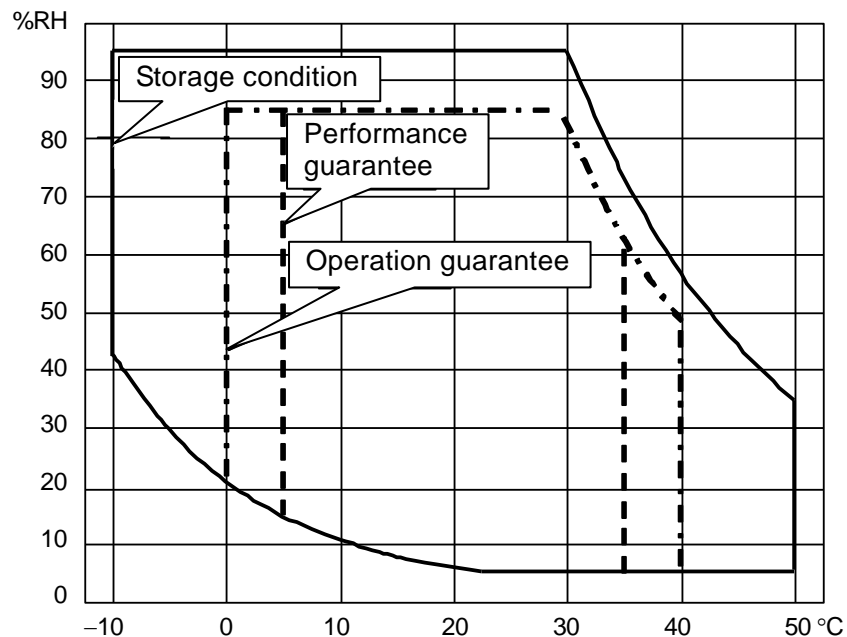

8.8 General Information

- Warm up time: 30 min. Accuracy specification apply after warm up.
- Pollution degree: 2 (indoor use)
- Safety regulations: EN 61010-1
EN 61010-2-030
- EMC: EN 61326-1 (Group1, Class A)
EN 61000-3-2
EN 61000-3-3
- RoHS: Directive 2011/65/EU
- External dimensions: 434(W) ×88(H)× 403(D) mm, not counting protuberances.
- Weight: About 6.8kg (not counting supplied parts)

Complements: Optional or related products are subject to modification or discontinuation without notice.

For orders, contact NF Corporation or one of our representatives.

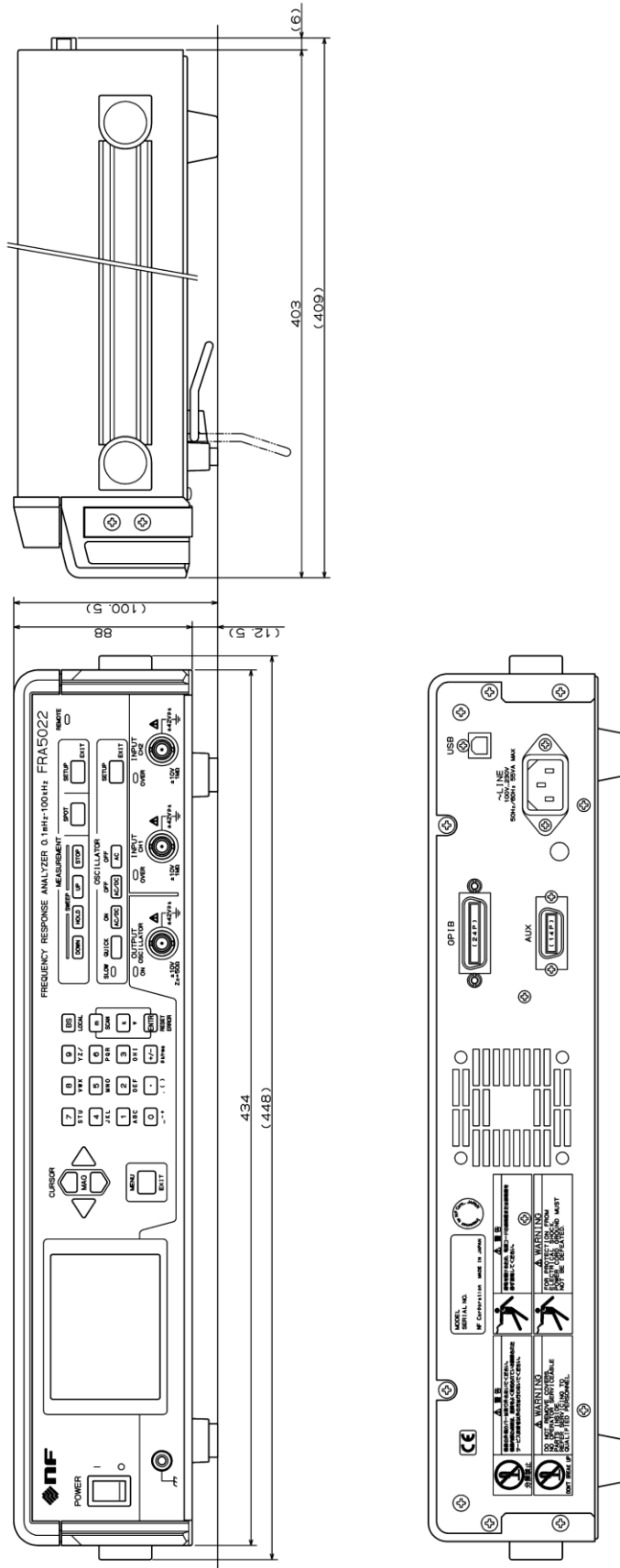

Figure 8-1 External dimensions

Rear panel figure

- Surface treatment
- Front panel: Plastic sheet Ultra light gray (Munsell 6PB9.2/0.1)
- Rear panel: Munsell 8.5PB2.6/0.2
- Cover: Light gray leather tone (Munsell 6PB7.6/1.2 leather tone)
- Bottom cover: Unichrome plated (trivalent)

WARRANTY

NF Corpoation certifies that this instrument was thoroughly tested and inspected and found to meet its published specifications when it was shipped from our factory.

All **NF Corpoation** products are warranted against defects in materials and workmanship for a period of one year from the date of shipment. During the warranty period of, **NF Corpoation** will, at its option, either will repair the defective product without any charge for the parts and labor, or either repair or replace products which prove to be defective. For repair service under warranty, the product must be returned to a service center designated by **NF Corpoation**. Purchaser shall prepay all shipping cost, duties, and taxes for the product to **NF Corpoation** from another country, and **NF Corpoation** shall pay shipping charge to return the product to purchaser.

This warranty shall not apply to any defect, failure or damage caused by improper use, improper or inadequate maintenance and care or modified by purchaser or personnel other than **NF** representatives.

NF CORPORATION

If there are any misplaced or missing pages, we will replace the manual. Contact the sales representative.

NOTES

- Reproduction of the contents of this manual is forbidden by applicable laws.
- The contents of this manual may be revised without notice.
- Information provided in this manual is intended to be accurate and reliable. However, we assume no responsibility for any damage regarding the contents of this manual.
- We assume no responsibility for influences resulting from the operations in this manual.

FRA5022 Instruction Manual

NF Corporation

6-3-20, Tsunashima Higashi, Kohoku-ku, Yokohama
223-8508 JAPAN
Phone +81-45-545-8128 Fax +81-45-545-8187
<http://www.nfcorp.co.jp/>

© Copyright 2007-2022, **NF Corporation**

