

DATA SHEET

Zirconia O₂ Sensors

Flange Mounted Series—O2S-FR T5



DESIGN • MANUFACTURE • CUSTOMISE • CONFIGURE

FEATURES

- Zirconium dioxide (ZrO₂) sensing elements
- Long life, non-depleting technology
- Integral heating element
- High accuracy
- Requires an external interface board to operate^a



Response Time



Heater Voltage



Gas Temp

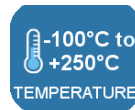

Termination

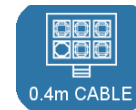

BENEFITS

- No reference gas required
- No need for temperature stabilisation
- Flange mounting

OUTPUT VALUES

Oxygen pressure range	2mbar—3bar max.
Accuracy	5mbar max.
Internal operational temp	700°C
Response time (10—90% step)	< 4s
Warm up time (prior to sensor operation)	100s
Warm up time (from standby)	20s
Output stabilisation time	~ 180s

TECHNICAL SPECIFICATIONS

Heater voltage ^b	
Operating	4.35V _{DC} ± 0.1V _{DC} (1.85A)
Standby	2V _{DC} (0.85A)
Pump impedance at 700°C ^c	< 6kΩ
Permissible gas temperature	-100°C to +250°C
Gas flow rate	0—10 m/s
Repetitive permissible acceleration	5g
Incidental permissible acceleration	30g
Termination	0.4m cable with Molex connector

Other sensor options available on request, email:
technical@sstsensing.com

Need help? Ask the expert
Tel: + 44 (0)1236 459 020
and ask for “Technical”



NOTES

- Interface board sold separately; contact technical@sstsensing.com for details.
- It is important to measure the heater voltage as close to the sensor as possible due to voltage drops in the supply cable. Heater can also be operated with an equivalent AC or PWM signals.
- The constant current source used in the pump circuit should be designed to drive a load of up to 6kΩ.

OUTLINE DRAWING

All dimensions shown in mm.

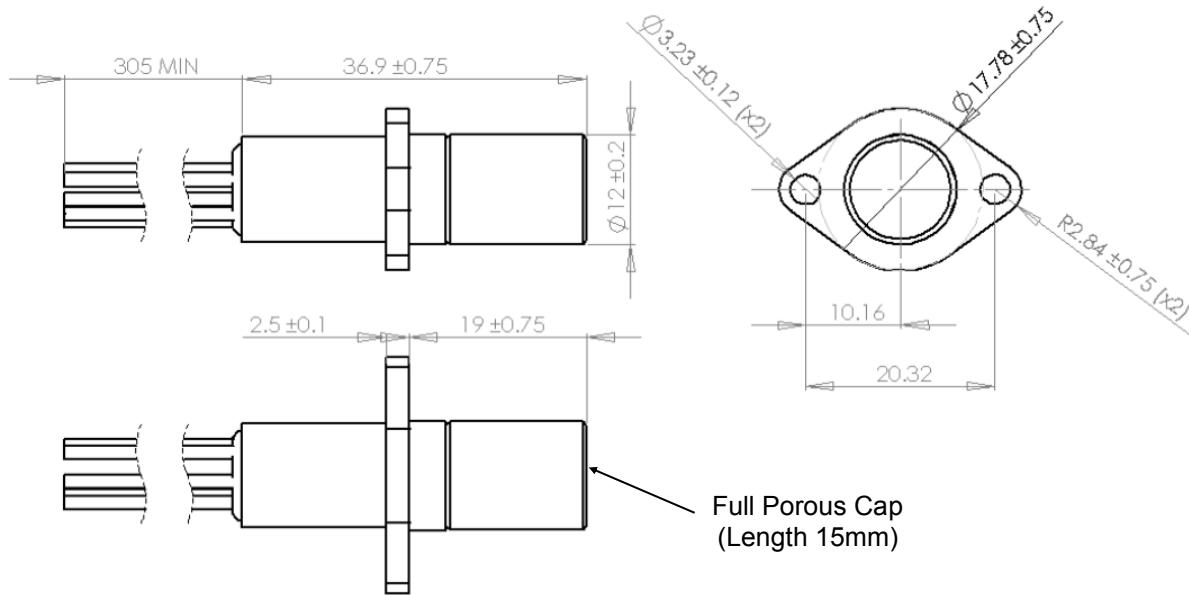

ELECTRICAL INTERFACE

Wire	Designation
1 : Red	Pump
2 : Black	Common
3 : Yellow	Heater (1)
4 : Blue	Sense
5 : Yellow	Heater (2)

ORDER INFORMATION

Specify the part number below when ordering.

O 2 S - F R - T 5

CAUTION

Do not exceed maximum ratings and ensure sensor(s) are operated in accordance with their requirements.

Carefully follow all wiring instructions. Incorrect wiring can cause permanent damage to the device.

Zirconium dioxide sensors are damaged by the presence of silicone. Vapours (organic silicone compounds) from RTV rubbers and sealants are known to poison oxygen sensors and MUST be avoided. Do NOT use chemical cleaning agents.

Failure to comply with these instructions may result in product damage.

INFORMATION

As customer applications are outside of SST Sensing Ltd.'s control, the information provided is given without legal responsibility. Customers should test under their own conditions to ensure that the equipment is suitable for their intended application.

For detailed information on the sensor operation refer to application note AN0043 Operating Principle and Construction of Zirconium Dioxide Oxygen Sensors.

For technical assistance or advice, please email:
technical@sstsensing.com

General Note: SST Sensing Ltd. reserves the right to make changes to product specifications without notice or liability. All information is subject to SST Sensing Ltd.'s own data and considered accurate at time of going to print.

DS-0080 REV 4

© 2018 SST SENSING LTD.

5 HAGMILL CRESCENT, SHAWHEAD INDUSTRIAL ESTATE, COATBRIDGE, UK ML5 4NS

www.sstsensing.com | e: sales@sstsensing.com | t: +44 (0)1236 459020 | f: +44 (0)1236 459026

Aufgrund laufender Weiterentwicklungen sind Änderungen der Spezifikationen vorbehalten. Alle Angaben vorbehaltlich Satz- und Druckfehler.

nbn Austria GmbH

Riesstraße 146, 8010 Graz

Tel. +43 316 40 28 05 | Fax +43 316 40 25 06

nbn@nbn.at | www.nbn.at



nbn