

P/N: T300240

Copyright

© 2023, FLIR Systems, Inc.

All rights reserved worldwide. Names and marks appearing herein are either registered trademarks or trademarks of FLIR Systems and/or its subsidiaries. All other trademarks, trade names or company names referenced herein are used for identification only and are the property of their respective owners.

Document identity

Publ. No.: T300240

Commit: 85780

Language:

Modified: 2022-06-20

Formatted: 2023-03-31

Website

<http://www.flir.com>

Customer support

<http://support.flir.com>

Disclaimer

Specifications subject to change without further notice. Camera models and accessories subject to regional market considerations. License procedures may apply. Products described herein may be subject to US Export Regulations. Please refer to exportquestions@flir.com with any questions.



General

When a camera is ordered the following must be selected, as a minimum:

1. one of the camera bodies:
 - FLIR A400 Thermal Core
 - FLIR A500 Thermal Core
 - FLIR A700 Thermal Core
2. one of the configurations:
 - Smart Sensor configuration
 - Image Streaming configuration
3. one (or several) of the lenses:
 - IR lens, f=70 mm (6°) with case
 - IR lens, f=29 mm (14°)
 - IR lens, f=17 mm (24°)
 - IR lens, f=10 mm (42°)
 - IR lens Dual FOV, f=17/29 mm (24°/14°)

For orders of more than one lens, select the primary lens to be mounted on the Thermal Core camera body at delivery. The additional lenses are then delivered in separate boxes. Due to its size, the IR lens, f=70 (6°), is always delivered in a case.

Please note that other P/Ns are used when the lenses are ordered as accessories.

The following options are available:

- Antenna WLAN 2.4/5 GHz + Wi-Fi
- Option, Visual camera including MSX
- Advanced Smart Sensor configuration
- Advanced Image Streaming configuration
- Option, Macro mode 50/71/101 µm for 24°

Note the following:

The *Advanced Smart Sensor configuration* and the *Advanced Image Streaming configuration* require the *Smart Sensor configuration* and the *Image Streaming configuration*, respectively.

Imaging and optical data

Field of view (FOV)	24° × 18°
Minimum focus distance	0.15 m (0.49 ft)
Minimum focus distance with MSX	0.5 m (1.64 ft)
Focal length	17 mm (0.67 in)



IR lens, f=17 mm (24°)

P/N: T300240

© 2023, FLIR Systems, Inc.

#T300240; r. 85780;

Imaging and optical data	
Spatial resolution (IFOV)	Dependent on the IR resolution of the camera: <ul style="list-style-type: none">• 320 × 240 pixels: 1.31 mrad/pixel• 464 × 348 pixels: 0.90 mrad/pixel• 640 × 480 pixels: 0.66 mrad/pixel
Lens identification	Automatic
F-number	1.3
Physical data	
Weight	0.140 kg (0.31 lb)
Size (L × D)	45.4 × 72 mm (1.79 × 2.83 in)
Shipping information	
Packaging, contents	<ul style="list-style-type: none">• Lens• Front lens cap
Country of origin	Sweden and/or Estonia

Compatible with the following products:

- 85900-0000; FLIR A700 Thermal Core
- 85900-1100; FLIR A700 Thermal Core, Optional temperature range
- 85902-0102; FLIR A700 24° Professional Science Kit
- 85902-0202; FLIR A700 24° Standard Science Kit
- 85903-0102; FLIR A700 24° f/1.0 Professional Science Kit
- 85903-0202; FLIR A700 24° f/1.0 Standard Science Kit
- 90600-0000; FLIR A500 Thermal Core
- 90600-1100; FLIR A500 Thermal Core, Optional temperature range
- 90610-0202; FLIR A500 24° Standard Science Kit
- 90611-0102; FLIR A500 24° Professional Science Kit
- 91900-0000; FLIR A400 Thermal Core
- 91900-1100; FLIR A400 Thermal Core, Optional temperature range
- 91902-0202; FLIR A400 24° Standard Science Kit
- 91903-0102; FLIR A400 24° Professional Science Kit

© 2016, FLIR Systems, Inc. All rights reserved worldwide. No part of this drawing may be reproduced, stored in a retrieval system, or transmitted in any form, or by any means, electronic, mechanical, photocopying, recording, or otherwise, without written permission from FLIR Systems, Inc. Specifications subject to change without further notice. Dimensional data is based on nominal values. Products may be subject to regional market considerations. License procedures may apply. Product may be subject to US Export Regulations. Please refer to exportquestions@flir.com with any questions. Diversion contrary to US law is prohibited.



Lens IR f=10mm (42°)

Lens IR f=17mm (24°)

Lens IR f=29mm (14°)

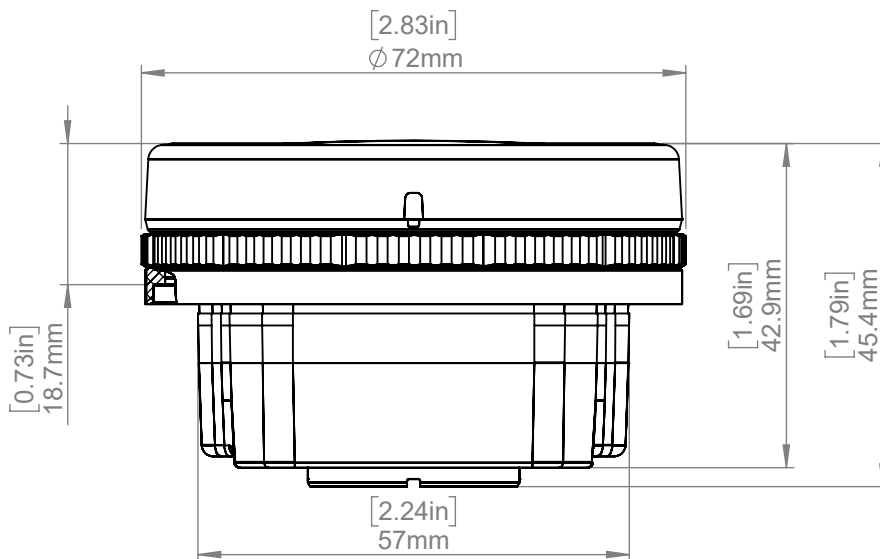
Lens IR Close-Up (2x) 



Modified 2019-09-30	Check JOHE	Drawn by R&D Instruments	
Denomination			
Basic dimensions for lenses T199104, T199105, T199106, T199598			Scale 1:1
			
Drawing No. T130322			Sheet 1(1)
			Rev B