

MODELS  
K2004E01 / K2007E01

## SMARTSHAKER™

- Integrated power amplifier eliminates the need for a separate, cumbersome power amplifier
- SmartShaker™ provides up to 7 lbf (31N) pk sine force with up to 1/2 in (13 mm) stroke
- 10-32 threaded mounting insert supports payloads up to 2 lb (0.907 kg)
- Trunnion mounting base with EasyTurn™ handles

### TYPICAL APPLICATIONS

- General vibration testing for small components, sub-assemblies, and biomedical
- Experimental modal analysis
- Educational laboratory research
- Mechanical impedance measurements

### MINI SHAKER WITH INTEGRATED POWER AMPLIFIER

This electrodynamic exciter is a small, portable permanent magnet shaker with a new generation of ultra compact precision power amplifier integrated in its base. The revolutionary SmartShaker™ design eliminates the need for a separate, cumbersome power amplifier - just plug the excitation signal from a dynamic signal analyzer or function generator directly into the BNC on the base of the shaker. The unit is supplied with a DC power supply but can be run directly from any 12-21 VDC supply.

The SmartShaker™ features an extremely rugged suspension systems using carbon fiber composite leaf armature flexures, avoiding the suspension damage common with some other small shakers. Isolated linear bearings provide low distortion and eliminate the need for reaction wrenches when mounting loads to the armature. A trunnion base with EasyTurn™ handle allows for convenient mounting and positioning. The exciter is delivered with a variety of 10-32 nylon stingers which provide electrical isolation from and flexible attachments to test articles.

| SPECIFICATIONS                               |   |                   |
|--|---|-------------------|
| Performance                                  | K2004E01                                | K2007E01          |
| Shaker Performance                           |   |                   |
| Output Force, sine pk                        |   |                   |
| Natural Air Cooling                          | 4.5 lbf (20 N)                          | 7 lbf (31 N)      |
| Output Force, random RMS                     |   |                   |
| Natural Air Cooling                          | 3 lbf (13.3 N)                          | 5 lbf (22 N)      |
| Output Force, shock pk                       | 9 lbf (40 N)                            | 15 lbf (67 N)     |
| Stroke Length                                |   |                   |
| Continuous pk-pk                             | 0.2 in (5 mm)                           | 0.5 in (13 mm)    |
| Between Stops                                | 0.35 in (9 mm)                          | 0.55 in (14 mm)   |
| Frequency Range <sup>[1]</sup>               | DC-11 kHz                               | DC-9 kHz          |
| Acceleration <sup>[1, 2]</sup>               |   |                   |
| No load                                      | 64 g pk                                 | 70 g pk           |
| 0.1 lb (0.045 kg) load                       | 26 g pk                                 | 35 g pk           |
| 1 lb (0.454 kg) load                         | 4.2 g pk                                | 6.4 g pk          |
| 2 lb (0.907 kg) load [max payload]           | 2.2 g pk                                | 3.3 g pk          |
| Maximum Current                              | 5 A                                     | 8 A               |
| DC Resistance, armature nominal              | 1.5 Ω                                   | 0.37 Ω            |
| Amplifier Performance                        |   |                   |
| Efficiency                                   | 92%                                     |                   |
| Input Voltage, RMS                           | 0-1 VAC <sup>[3]</sup>                  |                   |
| Input Voltage (absolute maximum), RMS        | 1.9 VAC                                 |                   |
| Input Power <sup>[4]</sup>                   | 12-21 VDC                               |                   |
| Output Power <sup>[5]</sup>                  | 55 W                                    |                   |
| Distortion, typical <sup>[6]</sup>           | < 0.02%                                 |                   |
| Cooling                                      | Convection                              |                   |
| Discrete Gain Stages, nominal <sup>[7]</sup> | Muted, 10 dB, 18 dB, 24 dB              |                   |
| Warning Indication <sup>[7]</sup>            | Clipping and over temperature           |                   |
| Shutdown Protection <sup>[7]</sup>           | Over temperature and over current       |                   |
| Physical                                     |   |                   |
| Armature Mass, nominal                       | 0.07 lb (0.032 kg)                      | 0.1 lb (0.045 kg) |
| Suspension Stiffness, nominal                | 15 lbf/in (2.63 N/mm)                   |                   |
| Input Connector                              | BNC jack                                |                   |
| Output Connector                             | Mini binding post                       |                   |
| Table Mounting                               | 10-32 thread                            |                   |
| Dimensions (H x W x D), nominal              | 5.3 x 6.75 x 3.5 in (135 x 171 x 89 mm) |                   |
| Weight                                       | 7 lb (3.10 kg)                          |                   |

| Supplied Accessories |  |
|----------------------|--|
| K2007E01-PS          | Power supply, 60 W, 19 V DC output, 100-240 V AC input   |
| 2110G06              | Nylon Stinger kit, 10-32 thread, pack of three   |
| Related Products     |  |
| 288D01               | PCB ICP® impedance head driving point sensor, PCB 208 series ICP® force sensors  |
| 2025E                | Modal Shaker, 25 lbf pk sine force, 0.75 in stroke, through-hole armature design                                       |
| 2060E                | Modal Shaker, 60 lbf pk sine force, 1.4 in stroke, with through-hole armature design                                   |
| 2100E11              | Modal Shaker, 100 lbf pk sine force, 1 in stroke, through-hole armature design   |
| 2075E                | Shaker, 75 lbf pk sine force, 1 in stroke, 3.25 in mounting platform with through-hole armature for stinger attachment |

- [1] Load dependent  
[2] Please see systems ratings for additional specifications  
[3] Typical, full output, gain dependent  
[4] Supplied with universal power supply, 60 W (19 V DC - 3.15 A output)  
[5] Based upon supplied universal power supply, 92 % efficiency  
[6] THD + noise at 1 kHz, 1 W  
[7] Indicated via LEDs

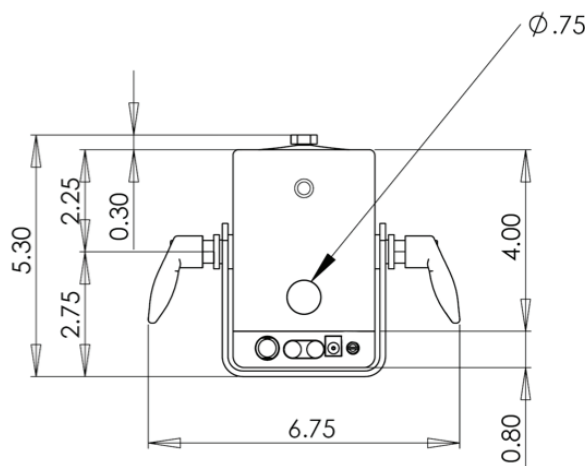

**Model K200xE01**  
Technical Drawing  
Dimensions in inches