

# GSMTM SERIES SUB-MINIATURE S-TYPE LOAD CELL (METRIC)

The Miniature S-Type Load Cell is a bi-directional Aluminum strain gauge based transducer with high performance and built-in temperature compensation. This design provides better than  $\pm 0.1\%$  (full scale) non-linearity and includes overload protection in both tension and compression directions.

## SPECIFICATIONS

Rated Capacity	4.5, 9, 20, 45, 110, 225, & 445 N
Rated Output (RO)	2mV/V nom.
Safe Overload	1000 % of R.O., 200% tension only for 225 & 445N
No Load Offset (Zero Balance)	$\pm 3\%$ of R.O.
Excitation (VDC Or VAC)	10 MAX, 5V recommended
Input Impedance	1000 $\Omega$ nom.
Output Impedance	1000 $\Omega$ nom.
Non-linearity	$\pm 0.1\%$ of R.O.
Hysteresis	$\pm 0.1\%$ of R.O.
Nonrepeatability	$\pm 0.1\%$ of R.O.
Temperature Shift Zero	$\pm 0.01\%$ of R.O./ $^{\circ}$ F ( $\pm 0.018$ of R.O./ $^{\circ}$ C)
Temperature Shift Span	$\pm 0.02\%$ of LOAD/ $^{\circ}$ F ( $\pm 0.036$ of LOAD/ $^{\circ}$ C)
Compensated Temperature	5 to 160 $^{\circ}$ F (-15 to 71 $^{\circ}$ C)
Operating Temperature	-60 to 200 $^{\circ}$ F (-51 to 93 $^{\circ}$ C)
Weight (Approx)	9 g
Material	Aluminum (4.5N – 45N), SS(110N – 445N)
Deflection	0.1mm nom.
Ip Rating	IP40
Calibration Test Excitation	5 VDC
Calibration (STD)	5 pt. Tension & Compression
Connector	DB9 Male or Female (specify at time of order)
Thread	M3x0.5

## STANDARD CONFIGURATION



Model GSMTM-4.5N-N-2 (Shown)

## WIRING DIAGRAM

The sensor is provided with a #32 AWG 4-conductor braided shielded cable with an outer jacket of 2.2 mm diameter, 2m long, with no connection between the shield and the sensor body. For additional protection, the cable is contained within a stainless steel spring for strain relief purposes for the first 25 mm.

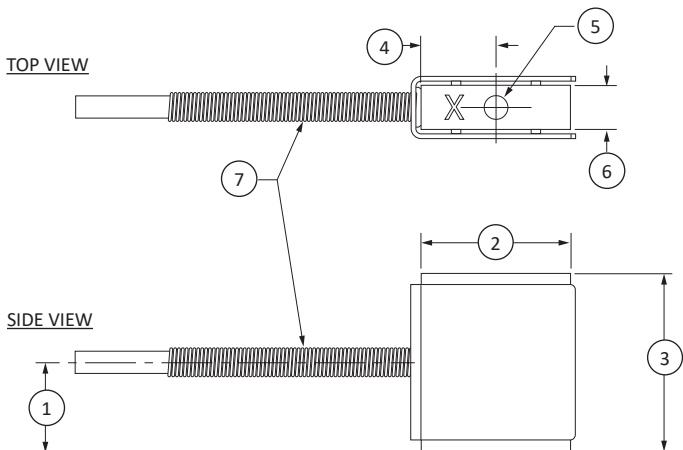
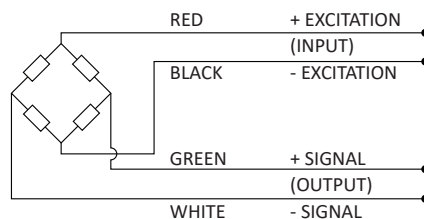

## DIMENSIONS

(1)	(2)	(3)	(4)	(5)	(6)	(7)
9.525	16.002	19.050	8.001	2 x Thread 2.8 Deep	4.700	Strain Relief Spring

\* All dimensions are in mm.

\*\* This product is not available in the United States.

