

# CT

## High Precision Current Transducers

### Specifications



# Sensor Specifications

Type	CT 100	CT 200	CT 400	CT 500	CT 1000	CT 2000
<b>Current Range</b>	100 A	200 A	400 A	500 A	1000 A	2000 A
<b>DC / AC<sub>rms</sub> (Crestfactor 2)</b>	100 A	200 A	400 A	500 A	1000 A	2000 A
<b>100 ms Overload</b>	20 kA <sub>pk</sub>	20 kA <sub>pk</sub>	20 kA <sub>pk</sub>	3 kA <sub>pk</sub>	5 kA <sub>pk</sub>	10 kA <sub>pk</sub>
<b>Ratio</b>	500 : 1	1000 : 1	1500 : 1	750 : 1	1500 : 1	2000 : 1
<b>Output Range</b>	0 ... 200 mA <sub>rms</sub>	0 ... 200 mA <sub>rms</sub>	0 ... 266.667 mA <sub>rms</sub>	0 ... 666.667 mA <sub>rms</sub>	0 ... 666.667 mA <sub>rms</sub>	0 ... 1 A <sub>rms</sub>
<b>Max. Measuring Resistance<sup>1</sup></b>	25 Ω	20 Ω	10 Ω	5 Ω	4 Ω	3.5 Ω
<b>Bandwidth (-3 dB)</b>	DC ... 2 MHz	DC ... 1.1 MHz	DC ... 800 kHz	DC ... 520 kHz	DC ... 440 kHz	DC ... 140 kHz
<b>Step Response (0 ... 90 %)</b>	0.2 μs	0.2 μs	1 μs	1 μs	1 μs	1 μs
<b>DC Accuracy (of MR)<sup>2</sup></b>	0.002 %	0.001 %	0.0008 %	0.00115 %	0.0012 %	0.0012 %
<b>AC Accuracy (of MV)<sup>3</sup></b>						
> 0 ... ≤ 100 Hz	0.015 %	0.015 %	0.015 %	0.015 %	0.015 %	0.015 %
> 100 ... ≤ 1000 Hz	0.025 %	0.02 %	0.02 %	0.02 %	0.02 %	0.05 %
> 1000 ... ≤ 10000 Hz	0.2 %	0.15 %	0.15 %	0.1 %	0.15 %	0.25 %
> 10000 ... ≤ 50000 Hz <sup>4</sup>	0.5 %	0.5 %	0.5 %	0.2 %	1.5 %	1 % <sup>4</sup>
> 50000 ... ≤ 100000 Hz	1 %	1 %	1 %	0.5 %	4 %	
<b>Angular Accuracy</b>						
> 0 ... ≤ 100 Hz	0.01 °	0.01 °	0.01 °	0.01 °	0.01 °	0.01 °
> 100 ... ≤ 1000 Hz	0.05 °	0.02 °	0.01 °	0.01 °	0.01 °	0.05 °
> 1000 ... ≤ 10000 Hz	0.1 °	0.05 °	0.1 °	0.05 °	0.1 °	0.1 °
> 10000 ... ≤ 50000 Hz <sup>4</sup>	0.25 °	0.25 °	0.5 °	0.5 °	1 °	1 ° <sup>4</sup>
> 50000 ... ≤ 100000 Hz	0.5 °	0.5 °	1 °	1 °	2 °	
<b>Temp.-Coefficient (of MR)</b>	0.2 ppm/K	0.2 ppm/K	0.1 ppm/K	1 ppm/K	0.3 ppm/K	0.1 ppm/K
<b>Temperature Range</b>	-40 ... 85 °C	-40 ... 85 °C	-40 ... 85 °C	-40 ... 85 °C	-40 ... 85 °C	-40 ... 85 °C
<b>Test Voltage 50 Hz</b>	4.95 kV	4.95 kV	4.95 kV	4.2 kV	4.2 kV	6 kV
<b>Inner Diameter</b>	28 mm	28 mm	28 mm	38 mm	38 mm	70 mm
<b>Mass</b>	0.275 kg	0.295 kg	0.305 kg	1.3 kg	1.3 kg	4.2 kg

<sup>1</sup> At full scale and 25 °C. For other current values and temperatures see graphs below. Max measuring resistance = cable loop resistance + burden resistance.

<sup>2</sup> Error of measuring range. At 25 °C.

<sup>3</sup> Error of measured value. For range 3 % ... 100 %. Test current 0 ... 100 Arms, DC ... 100 kHz. At 25 °C.

<sup>4</sup> CT 2000: 10000 ... ≤ 20000 Hz. The precision frequency range of CT 2000 is limited to 20 kHz.

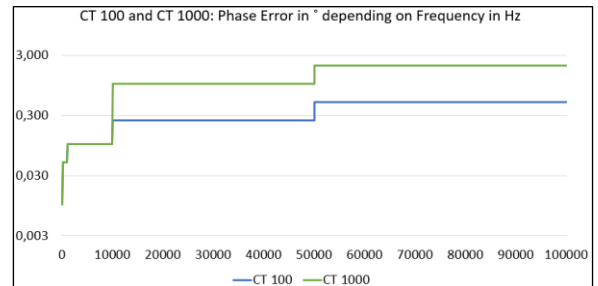
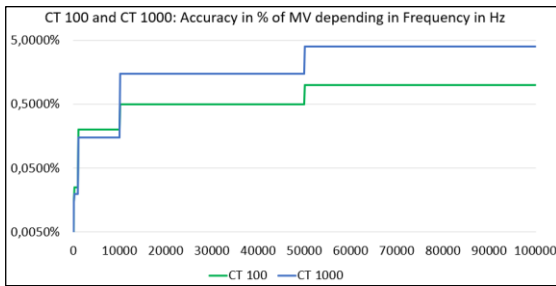

Maximum measuring resistance (cable- + burden-resistance) depending on primary rms current and surrounding temperature

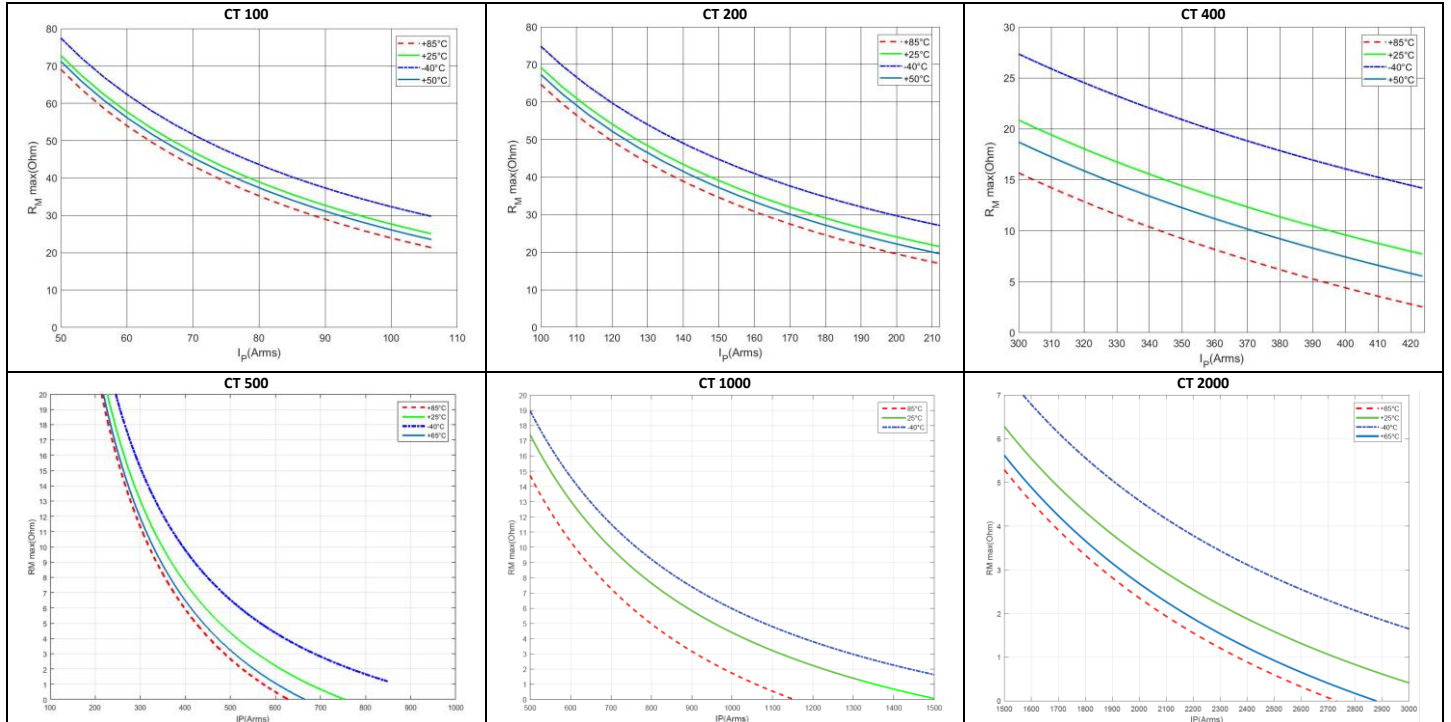

## Dimensions

### Transducers CT 100, CT 200, CT 400

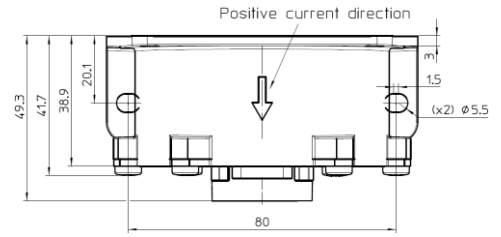
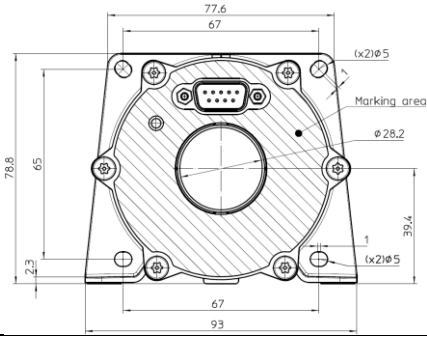

### Transducers CT 500, CT 1000

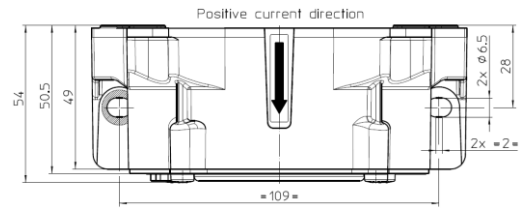
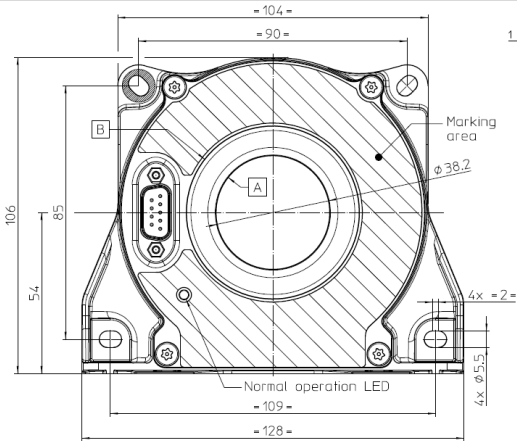

### Transducer CT 2000

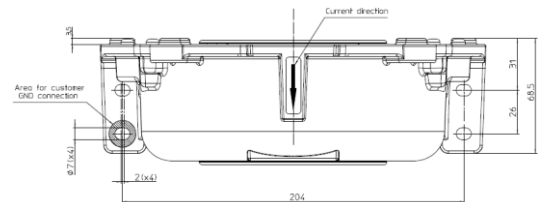
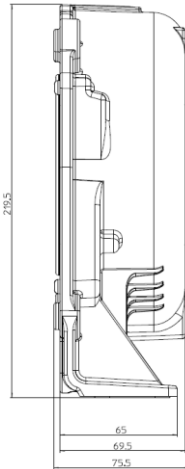
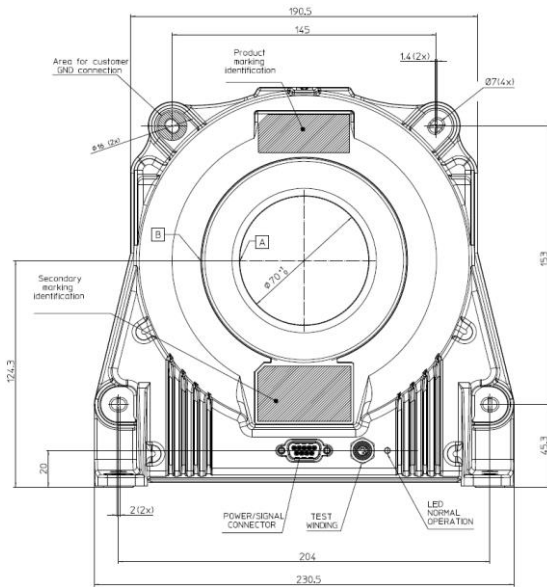

## Order Numbers

CT 100	AC/DC current transducer 100 A <sub>rms</sub>
CT 200	AC/DC current transducer 200 A <sub>rms</sub>
CT 400	AC/DC current transducer 400 A <sub>rms</sub>
CT 500	AC/DC current transducer 500 A <sub>rms</sub>
CT 1000	AC/DC current transducer 1000 A <sub>rms</sub>
CT 2000	AC/DC current transducer 2000 A <sub>rms</sub>