

Current Transducer SIGNALTEC CT 2000

(IN 2000-S/SP2)

$I_{PN} = 2000 \text{ A}$

For the electronic measurement of current: DC, AC, pulsed..., with galvanic separation between the primary and the secondary circuit.

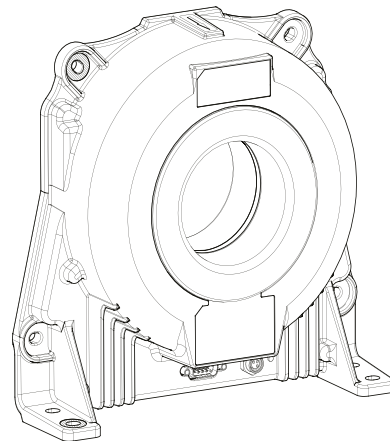

Features

- Closed loop (compensated) current transducer using an extremely accurate zero flux detector
- Electrostatic shield between primary and secondary circuit
- 9-pin D-Sub male secondary connector
- Status signal to indicate the transducer state
- LED indicator confirms normal operation
- Metal housing to improve immunity to EMC & power dissipation
- Operating temperature $-40 \text{ }^{\circ}\text{C}$ to $85 \text{ }^{\circ}\text{C}$.

Special feature

- Customer label dedicated to "Signaltec" (Product name: CT 2000).

Advantages

- Very high accuracy
- Excellent linearity
- Extremely low temperature drift
- Wide frequency bandwidth
- High immunity to external fields
- No insertion losses
- Very low noise on output signal
- Low noise feedback to primary conductor.

Applications

- Feed back element in high performance gradient amplifiers for MRI
- Feedback element in high-precision, high-stability power supplies
- Calibration unit
- Energy measurement
- Medical equipment.

Standards

- EN 61000-6-2: 2005
- EN 61000-6-3: 2007
- EN 61010-1: 2010.

Application Domain

- Industrial
- Laboratory
- Medical.

Insulation coordination

Parameter	Symbol	Unit	Value	Comment
Rated insulation RMS voltage, basic insulation	U_{Nm}	V	1000	IEC 61010-1 conditions - over voltage cat III - pollution degree 2
Rated insulation RMS voltage, reinforced insulation			1000	IEC 61010-1 conditions - over voltage cat III - pollution degree 2
RMS voltage for AC insulation test, 50 Hz, 1 min	U_d	kV	6	Between primary and secondary + shield
		V DC	100	Between secondary and test winding
Impulse withstand voltage 1.2/50 μ s	U_{Ni}	kV	12.8	
Clearance (pri. - sec.)	d_{Cl}	mm	21	Shortest distance through air
Creepage distance (pri. - sec.)	d_{Cp}	mm	22	Shortest path along device body
Comparative tracking index	CTI		250	

Environmental and mechanical characteristics

Parameter	Symbol	Unit	Min	Typ	Max	Comment
Ambient operating temperature	T_A	°C	-40		85	
Ambient storage temperature	$T_{A\ st}$	°C	-40		85	
Relative humidity	RH	%	20		80	
Dimensions						See drawing in page 8
Mass	m	kg		4.2		

Electrical data

 At $T_A = 25\text{ °C}$, $\pm U_C = \pm 15\text{ V}$, unless otherwise noted.

 Lines with a * in the comment column apply over the $-40 \dots 85\text{ °C}$ ambient temperature range.

Parameter	Symbol	Unit	Min	Typ	Max		Comment
Primary nominal DC current (continuous)	I_{PNDC}	A	-2000		2000	*	
Primary nominal RMS current	I_{PN}	A			2000	*	
Primary current, measuring range	I_{PM}	A	-3000		3000	*	
Measuring resistance	R_M	Ω	0		1		See curve page 5
Secondary nominal RMS current	I_{SN}	A	-1		1	*	
Number of secondary turns	N_S			2000			
Resistance of secondary winding	R_S	Ω		4			
Maximum withstand primary peak current ¹⁾	\hat{I}_{Pmax}	kA	-10		10		@ pulse of 100 ms
Supply voltage positive	$+U_C$	V	14.25	15	15.75		
Supply voltage negative	$-U_C$	V	-15.75	-15	-14.25		
Current consumption positive	$+I_C$	mA	180	200	225		Add I_S for total current consumption
Current consumption negative	$-I_C$		80	89	100		
Output RMS noise current 0 ... 10 Hz ²⁾	I_{no}	ppm		0.1			
Output RMS noise current 0 ... 10 kHz ²⁾				4			
Output RMS noise current 0 ... 160 kHz ²⁾				20			
Output peak-to-peak noise current ²⁾	$I_{no pp}$	ppm		50			
Electrical offset current + self magnetization + effect of earth magnetic field ²⁾	I_{OE}	ppm	-10		10	*	
Temperature coefficient of I_{OE} @ $I_P = 0\text{ A}$	TCI_{OE}	ppm/K		0.1			
Offset stability ²⁾		ppm/month	-1		1		
Linearity error ²⁾	ε_L	ppm		1	2		
				2	3	*	
Delay time to 90 % of the final output value for I_{PNDC} step	t_{D90}	μs			1		di/dt of 100 A/ μs
Frequency bandwidth ($\pm 1\text{ dB}$)	BW	kHz		130			Small-signal bandwidth, 0.5 % of I_{PN}
Frequency bandwidth ($\pm 3\text{ dB}$)	BW	kHz		140			
Test current	I_T	A			1		
Number of turns (test winding)	N_T			200			
Start-up time	t_{start}	s	2	5	15		

Notes: ¹⁾ Single pulse only, not AC. The transducer may require a few seconds to return to normal operation when autoreset system is running

²⁾ All ppm figures refer to full-scale which corresponds to a secondary nominal RMS current of 1 A.

Overload protection - Electrical specification - Status

The overload occurs when the primary current I_p exceeds a trip level such that the fluxgate detector becomes completely saturated and, consequently, the transducer will switch from normal operation to overload mode.

This trip level is guaranteed to be greater than I_{PM} and its actual value depends on operating conditions such as temperature and measuring resistance.

When this happens, the transducer will automatically begin to sweep in order to lock on the primary current again.

The overload conditions will be:

- The secondary current I_s generated is a low frequency signal.
- The signal normal operation status (between pin 3 and 8 of the D-sub connector) switches to $V+$. In other words, the output transistor is switched off (i.e., no current from collector to emitter). See the status port wiring below.
- The green LED indicator (normal operation status) turns off.

The measuring can resume when the primary current returns in the measuring range between $-I_{PN}$ and $+I_{PN}$. Then the signal normal operation status switches to GND and the green LED indicator (normal operation status) is again lit.

Status/Interlock port wiring

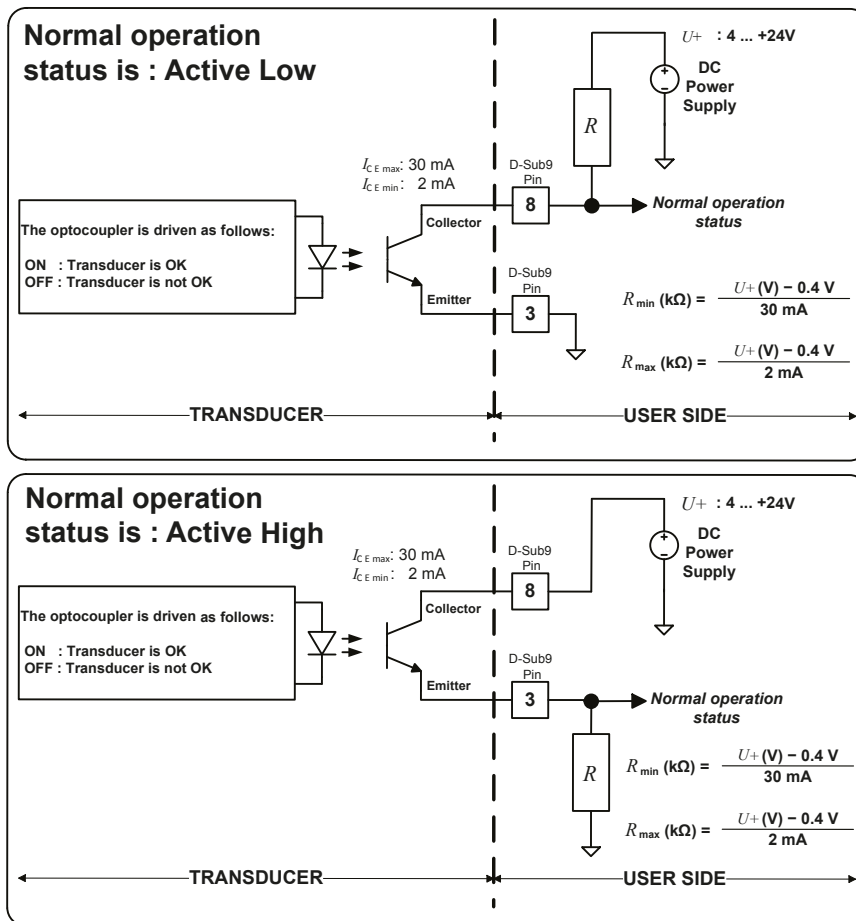

The following table shows how the normal operation status acts as below:

Status	Value	Description
Active Low	$\approx 0.7 \text{ V}$	The transducer is OK (Normal operation)
	$U+$	The transducer is not OK (Overload mode or supply fault)
Active High	$U+$	The transducer is OK (Normal operation)
	$\approx 0.7 \text{ V}$	The transducer is not OK (Overload mode or supply fault)

The following table shows how the normal operation status acts as below:

Normal operation status	Description
< 0.7 V	The transducer is OK (Normal operation)
$U+$	The transducer is not OK (Overload mode or supply fault)

Maximum measuring resistor versus primary current and temperature

$\pm U_C = \pm 14.25$ V

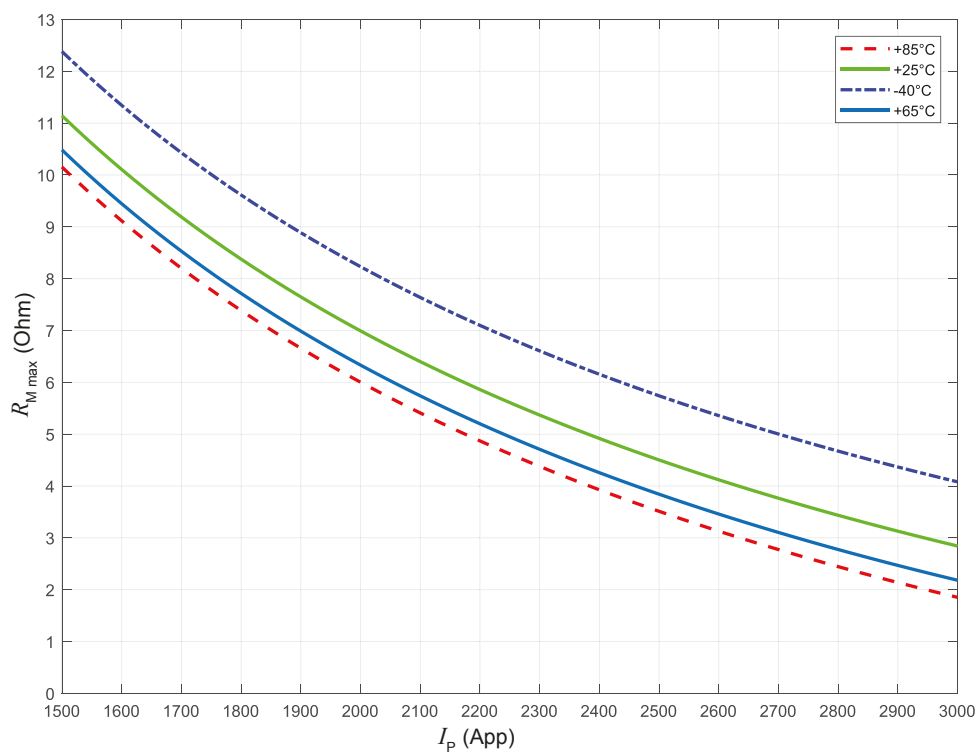
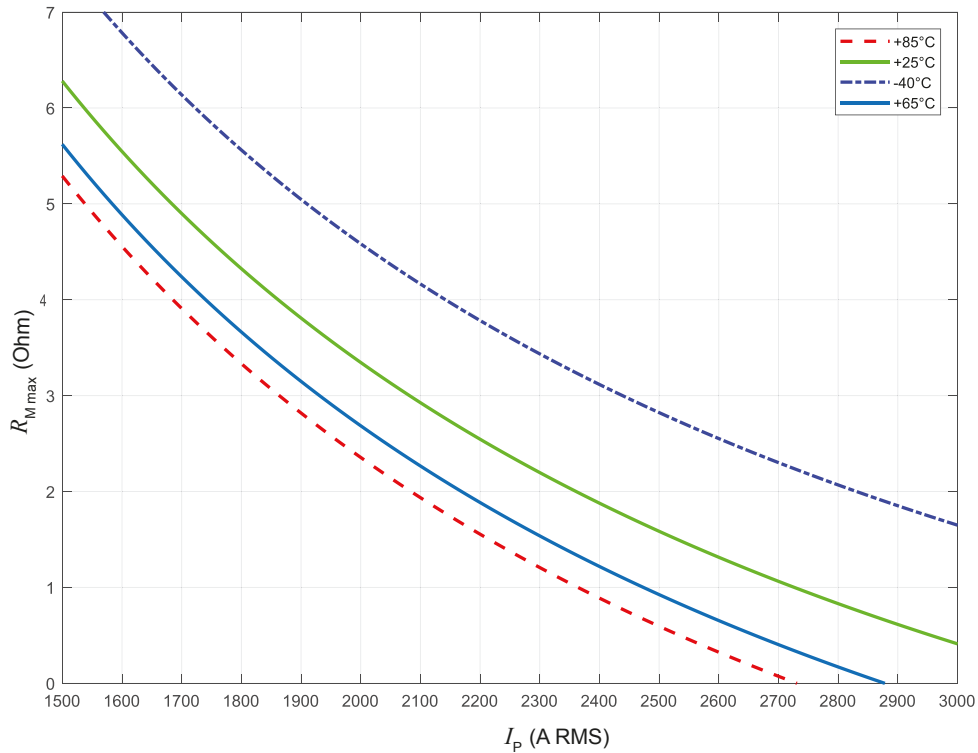

Power supply and load

In order to reach the measuring range according to the maximum measuring resistor, be careful with the setup measurement when wires length are high. It means that:

- the wires resistance could be not negligible
- the voltage at the output of the DC power supply and the voltage at the transducer could be significantly different.

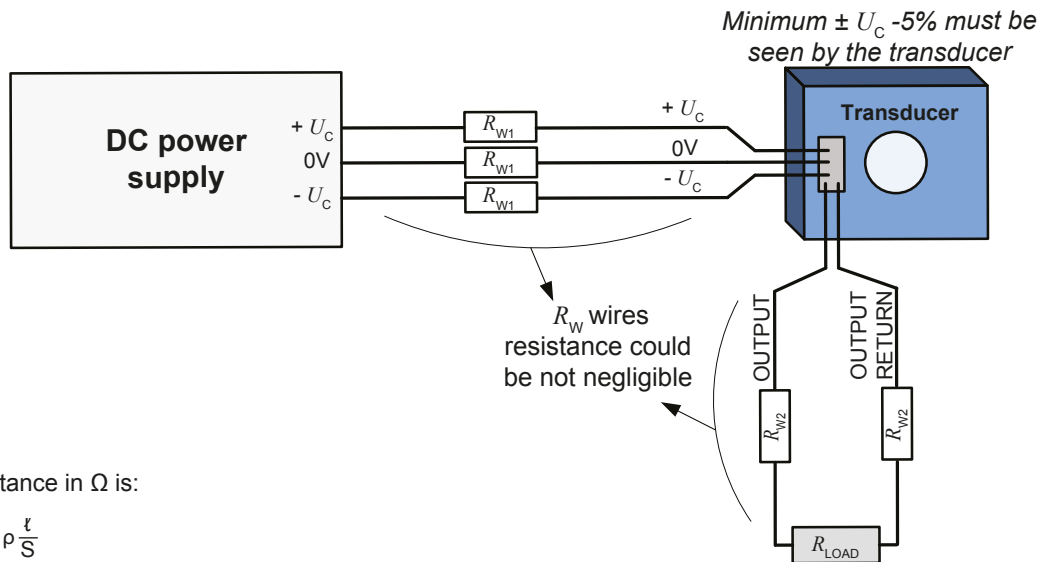

R_w wire resistance in Ω is:

$$R_w = \rho \frac{l}{S}$$

- S: Cross section of wire in m^2
 l: Wire length in m
 ρ : Resistivity of material in $\Omega \cdot m$

Total measuring resistance is:

$$R_M = R_L + 2 \times R_{W1} + 2 \times R_{W2}$$

If $R_{W1} = R_{W2} = R_{WIRE}$ then $R_M = R_L + 4 \times R_{WIRE}$

Safety

This transducer must be used in limited-energy secondary circuits according to IEC 61010-1.



This transducer must be used in electric/electronic equipment with respect to applicable standards and safety requirements in accordance with the manufacturer's operating instructions.



Caution, risk of electrical shock

When operating the transducer, certain parts of the module can carry hazardous voltage (e.g. primary busbar, power supply). Ignoring this warning can lead to injury and/or cause serious damage.

This transducer is a build-in device, whose conducting parts must be inaccessible after installation.

A protective housing or additional shield could be used. Main supply must be able to be disconnected.

Remark

Installation of the transducer must be done unless otherwise specified on the datasheet, according to LEM Transducer Generic Mounting Rules. Please refer to LEM document N°ANE120504 available on our Web site:

[Products/Product Documentation](#).

