

# CD603

## Condumax Dew-Point Analyzer

Automatic online hydrocarbon and water dew-point analyzer for natural gas



### Highlights

- Fundamental cooled-/chilled-mirror dew-point measurement principle
- Fully automatic identification of both water and hydrocarbon dew point
- Greater than 65 °C (117 °F) measurement depression range
- ±0.5 °C (±0.9 °F) hydrocarbon dew-point accuracy
- IECEx, ATEX, cQPSus and UKEX certifications
- 100 barg (1450 psig) operating pressure rating
- 3 x 4...20 mA user-configurable outputs
- 1 x system alarm, 3 x process alarms, selectable for all measurement parameters
- Modbus RTU or TCP/IP interface

### Applications

- Natural Gas Processing
- Transmission Pipeline Monitoring
- Gas-quality measurements at custody transfer
- Confirmation and control of fuel gas 'superheat' to turbine power plant
- Suitable for use with natural gas containing up to 20 % hydrogen with no further modification required

# Introducing the CD603 Condumax Dew-Point Analyzer



## Hydrocarbon Dew Point: A Critical Natural Gas Quality Parameter

For natural gas producers, pipeline operators, and direct contract buyers, hydrocarbon dew point is difficult to measure and control. It is vital to avoid custody transfer disputes, which can result in shut-ins due to today's tighter contractual limits.

Since 1986, the direct chilled mirror technique incorporated in the Michell Instruments Condumax II has been the definitive method of measuring hydrocarbon dew point, and is preferred by most gas producers, pipeline operators, and direct contract buyers around the world.

## Introducing the CD603 Dew-Point Analyzer

The CD603 dew-point analyzer extends this capability with a new detection technology for fundamental cooled mirror measurement of both hydrocarbon (HCdp) and water (Wdp) dew points and adds the latest features and specifications to a proven measurement technique.

The analyzer offers the user the opportunity to standardize on a hydrocarbon dew-point measurement technology that provides excellent correlation to potential hydrocarbon liquid content (PHLC), Equations of State calculations of extended composition analysis by laboratory GC, and the Bureau of Mines method in an instrument that is simple to install and operate.

## Precise and Automated Measurement

The single measurement sensor is designed to detect first condensable component and differentiate between hydrocarbon and water dew-point automatically using a fundamental chilled mirror principle.

Mirror cooling is achieved by a thermoelectric heat pump under the control of the instrument's firmware, with a PT1000 temperature sensor fixed under the mirror. The cooling rate is therefore precisely controlled to enable sensitive detection and repeatable measurements in accordance with the relevant ASTM and ISO test methods specific to dew point in natural gas.

This new cell design provides greater than 65 °C (117 °F) measurement depression range with automated HCdp and Wdp measurement modes and gives superior sensitivity to the previous generation of HCdp analysis products.

**Reduced methane emission** We acknowledge methane emission concerns with the innovative cooled-mirror sensor cell of the CD603, which operates with only 0.1 NI/min, representing best-in-class performance.

All measurement parameter data for multiple measurement cycles can be stored for later review, either using the instrument's HMI color display or by Modbus connection to the customer's PC.

The high-contrast color LC display with four-button user interface presents all measured data to the user in a clear and understandable format. The main display incorporates a real-time trend graph and alarm indicators based on the NAMUR 102 standard. A powerful and intuitive HMI makes control, logging and configuration of analyzer parameters easy.

The analyzer provides three user-configurable analog outputs, and Modbus RTU/TCP communications, allowing it to interface with a SCADA DCS system, or by a computer using the dedicated application software. A set of 4 adjustable volt free alarm contacts allow the CD603 to be used for direct process control.

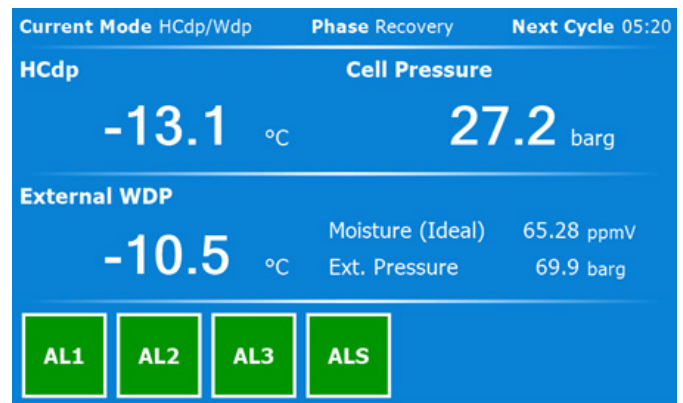

Main Display Example

## CD603 Dew-Point Analyzer

The CD603 Analyzer is designed for continuous, automatic measurement of the hydrocarbon dew point and water dew point of processed natural gas. It is the result of over 50 years' experience in the supply of analyzers to the worldwide oil, gas and petrochemical industry.

### Fully Hazardous-Area Capable

The system consists of a hydrocarbon and water dew-point measurement sensor cell and control electronics housed in an Exd enclosure. It is also possible to supply a sample gas handling panel to prepare the gas sample prior to entry into the analyzer. The analyzer is designed to be positioned close to the process sample point. It is ATEX, UKEX and IECEx approved and is also approved for use in North America in accordance with the requirements for the USA and Canada.

### Optional Dedicated Wdp Measurement

By using an optional Exd ceramic metal-oxide transmitter, continuous real-time Wdp measurement operating at full pipeline pressure is also possible. This enables the cooled-mirror sensor to operate in parallel, at intermediate pressure, to measure HCdp on continuous 10-minute cycles at the circondentherm condition or any analysis pressure stipulated in the gas supply specification.

### Minimal and Straightforward Maintenance

Sophisticated analyzers are often complicated and require experience and special care in use, increasing cost of ownership. The CD603 differs through its very uncomplicated approach to field service and has been designed with ease of access and serviceability in mind.

### Purpose-Designed Sample System

Indoor and outdoor sampling systems are available, providing comprehensive sample conditioning of natural gas at any pressure up to 100 barg (1450 psig) for the standard design. Our CD603 sample system facilitates regulation of pressure and flow, as well as the removal of contaminants, delivering a properly conditioned sample to the analyzer for reliable measurements and trouble-free operation.



The outdoor version is housed in an IP66 rated, insulated stainless-steel enclosure. The optional thermostatically controlled heating ensures reliable operation, with no condensate or water drop-out prior to measurement. For both the indoor and outdoor sampling systems, the CD603 main unit is mounted integral to the sampling system. The optional standard sample system is constructed from 316 stainless-steel components, and custom designs are also available.

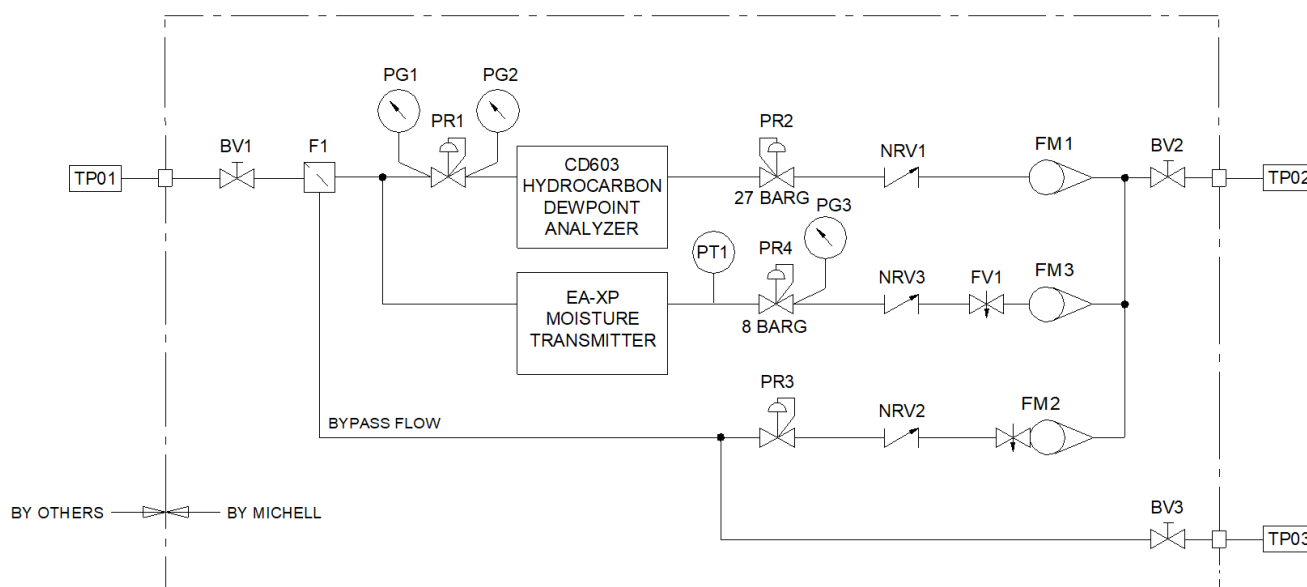

# Technical Specifications

Hydrocarbon & Water Dew-Point Measurement	
<b>Measuring Technique</b>	Chilled Mirror
<b>Sensor Cooling</b>	Automated cooling rate control
<b>Maximum Range</b>	Maximum cooling = >65 °C (117 °F) ΔT from analyzer operating temperature
<b>HCdp Accuracy</b>	± 0.5 °C (± 0.9 °F)
<b>Wdp Accuracy</b>	± 0.8 °C (± 1.4 °F)
<b>Resolution</b>	0.1 °C (0.1 °F)
<b>Sample Flow</b>	Nominally 0.1 NI/min (0.0035 scfm)
Pressure Measurements HCDP & WDP	
<b>Units</b>	MPa, barg, psig
<b>Resolution</b>	0.1 MPa, 0.1 barg, 1 psig
<b>Accuracy</b>	± 0.25 barg (3.6 psig)
Hydrocarbon Dew-Point Analyzer	
<b>Operating Pressure</b>	Up to 100 barg (1450 psig) – Ex db IIB+H2 T3 Gb Up to 60 barg (870 psig) – Ex db IIB+H2 T6 Gb *
<b>Enclosure</b>	Cast LM25 Alloy IP66/UL Type 4X Coating: Epoxy primer, powder coat polyester suitable for marine applications
<b>Gas Connections</b>	1/8" NPT
<b>Operating Environment</b>	-30 °C...+50 °C (-22 °F...+122 °F) max 95 %rh
<b>Weight</b>	23 kg (51 lb)
<b>Display &amp; User Interface</b>	High-definition 5" full color display, operated by 4 capacitive touch pads
<b>Logging &amp; Charting</b>	Up to 288 log samples (equivalent to 48 hrs of data in 10-minute measurement cycles)
<b>Hazardous Area Certification</b>	<b>ATEX/UKEX:</b> II 2 G Ex db IIB+H2 T3 Gb (Tamb -20 °C...+55 °C)
	<b>IECEx:</b> Ex db IIB+H2 T3 Gb (Tamb -20 °C...+55 °C)
	<b>cQPSus:</b> Class I, Division 1, Gr BCD T3 (Tamb -25 °C...+55 °C) Class I, Zone 1 AEx db IIB+H2 T3 Gb (Tamb -20 °C...+55 °C) Ex db IIB+H2 T3 Gb (Tamb -20 °C...+55 °C)
Interfaces	
<b>Analog Outputs</b>	Three 4...20 mA linear (non-isolated) outputs, user configurable for any combination of dew-point or pressure parameters. Max shunt resistance 400 ohms.
<b>Digital Outputs</b>	1 x system alarm, 3 x process alarms, selectable for all warnings and measurement parameters, all volt-free changeover.  Modbus RS485 or TCP/IP
Optional Continuous Water Dew-Point Measurement	
<b>Range</b>	-100...+20 °C (-148 °F...+68 °F) dew point
<b>Accuracy</b>	± 1...2 °C (± 1.8...3.6 °F) Wdp
<b>Parameters and Units</b>	°C and °F Wdp, moisture content lb/MMscf, ppm <sub>v</sub> , mg/m <sup>3</sup> (15 °C/59 °F), analysis pressure barg, psig, MPa
<b>Analysis Pressure</b>	Up to 100 barg (option dependant)
Power Supply	
<b>AC Version (Ex1)</b>	85...264 V AC, 50/60 Hz, 18 W 36 VA
<b>DC Version (Ex2)</b>	18...36 V DC, 18 W

\* To order T6 rated units, please contact your local sales team

## Product Dimensions

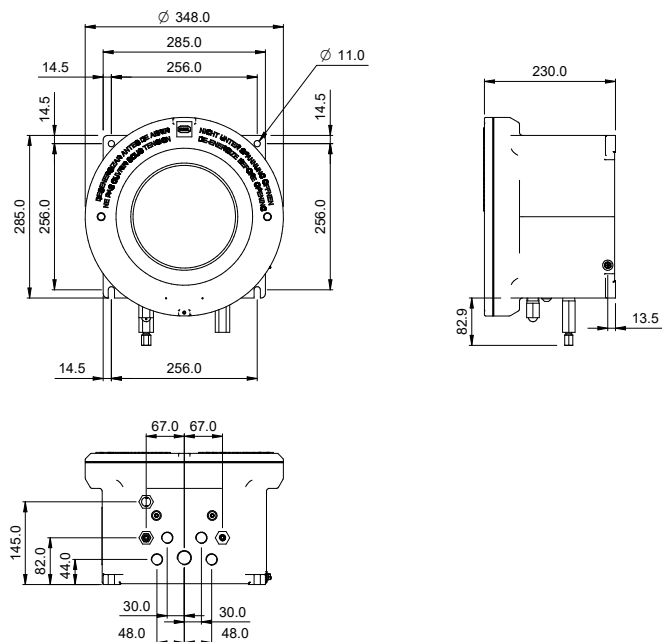

## Related Process Products



**CDP301**  
Condumax Dew-Point Tester

Michell Instruments adopts a continuous development programme which sometimes necessitates specification changes without notice.  
Issue no: CD603\_97148\_V1\_EN\_Datasheet\_0125