

Bipolar DC Power Supply

BP Series

Wide Range
Voltage Output

±60V

×

Large Current
Output

±100A
max.

Constant
Current

CC

/ Constant
Voltage

CV



BP4610 **±10A**

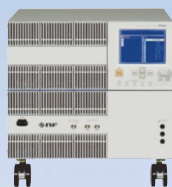

BP4620 **±20A**



BP4650 **±50A**



BP46100 **±100A**

**LINE
UP**

BP4610 (±10A) / BP4620 (±20A) / BP4630 (±30A) / BP4640 (±40A) / BP4650 (±50A)
BP4660 (±60A) / BP4670 (±70A) / BP4680 (±80A) / BP4690 (±90A) / BP46100 (±100A)

NF Corporation

Wide Output Range, Variety of Application

For Various Automotive Components, Motor, Solenoid, Capacitor and Others

BP series is a high voltage, large current, high speed bipolar power supply with built-in sequence function. In addition to a bipolar output that allows plus, minus, source, and sink, it has a sequence function that can freely program the output pattern.

LINEUP



BP4610 ±10A



BP4620 ±20A



BP4630 ±30A

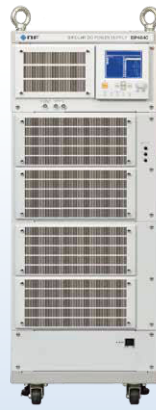

BP4640 ±40A

BP4650 ±50A



BP4660 to BP46100

±60A ±100A

The appearance and dimension of BP4670 / BP4680 / BP4690 are the same as BP4660 / BP46100.

	BP4610	BP4620	BP4630	BP4640	BP4650	BP4660	BP4670	BP4680	BP4690	BP46100	
Voltage	± 60 V, 120 Vp-p By the limiter setting, the output range can be shifted to - 5 V to + 115 V and - 115 V to + 5 V (Output current range changes)										
Current	DC	±10A	±20A	±30A	±40A	±50A	±60A	±70A	±80A	±90A	±100A
	AC	±15A	±30A	±45A	±60A	±75A	±90A	±105A	±120A	±135A	±150A
Low amplitude frequency response	DC to 200 kHz (CV, adjusted, amplitude 12 Vp-p) , DC to 70 kHz (CC, adjusted, amplitude 12 Vp-p)					DC to 170 kHz (CV, adjusted, amplitude 12 Vp-p) , DC to 70 kHz (CC, adjusted, amplitude 12 Vp-p)					

Features

- Voltage/Current 4 Quadrants Operation
- Wide range voltage output ±60 V (possible to shift the range)
10 Models, ±10 A to ±100 A
- High speed, DC to 150 kHz (CV, Adjusted)
- Constant voltage(CV) / Constant current(CC) operation selectable
- Up to 255 Steps sequence function
- Response calibration function
- Voltage Limiter / Current Limiter
- Measurement function (Output voltage / Output current)
- Analog input as power amplifier

Wide Range Output Area Voltage / Current 4 Quadrants Operation

BP series can output in four quadrants and is capable of handling two directions of current, which are source (supply) and sink (absorption) current.

From devices that generate back electromotive force such as solenoids, capacitive load such as electrolytic capacitor, and even to piezoelectric material charged with electromotive force and power sources and batteries such as fuel cells, you can drive the devices and systems that cannot be driven with generic DC power supply.

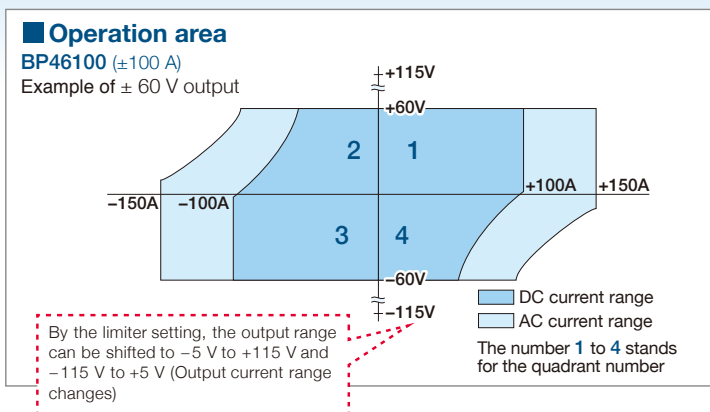

High Voltage / Large Current / Wide Range, Constant Current Operation

Output voltage is ± 60 V covering the range required in testing vehicle electrical components. Also BP series have large current necessary for large parts, high speed required in driving actuators, and constant current operation effective in driving low impedance solenoids.

With such enriched specification satisfying all such requirements, BP series responds to the needs in development and test of devices. With the lineup from ± 10 A to ± 100 A, BP will respond a variety of application

Sequence Function

BP series has a built-in sequential signal source. For example, by programming a series of voltage change pattern used in voltage fluctuation test on electrical and electronic components, the test can be done in a single operation since the output changes in order according to the procedure.

- Number of sequences : 1 sequence for each of the CV mode and CC mode
- Number of steps : 1 to 255 (within 1 sequence)
- Step time : 0.1 ms to 999.9999s (resolution 0.1 ms)
- Parameters : DC voltage, superimposed AC voltage, frequency and waveforms
- Jump count : 1 to 999, or continuous
- Sequence control : Start, Stops, Hold, Branch

The bundled software allows user to edit the complicated pattern easily

Various output patterns using sequence functions

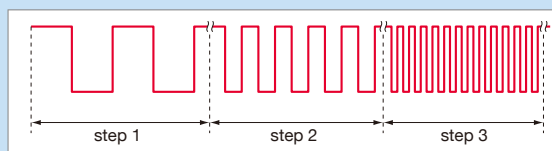

Ex.1 Relay Operation Test (Withstand Power Supply Fluctuation Test)

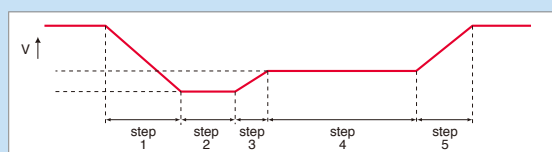

Ex.2 Vehicle Electrical and Electronic Components Test (ISO / DIS7637-2.2 Pulse 4) (Simulation of Transient Voltage Drops at Startup)

Control Software

The software is bundled that allow user to set the basic parameters, to collect the data, to edit the sequence / the arbitrary waveform and to control the sequence. This will support the data analysis and automate of production line.



▲ Remote control



▲ Sequence edit



▲ Arbitrary waveform edit



▲ Data logging

Response Calibration Function

Transient response for load with complicated impedance characteristic such as electromagnetic components with inductance (coil component) or capacitance (capacitor component) differs among loads. BP series has a response calibration function that allows users to individually optimize transient response characteristic in square wave output or sudden output change.

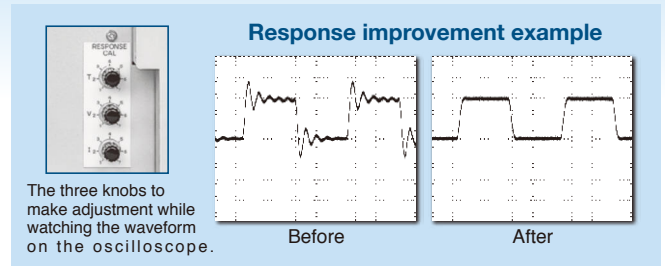

Voltage Limiter / Current Limiter

BP have the capability to set each of the maximum voltage and current with + and - independently. When shifting the output voltage range, voltage limiter is used.

Other Functions

- Voltage / Current output monitor
- Measurement function
To measure and display the output voltage / current (DC value and p-p value)
- Output on / off function
- External signal input for signal source
- External control I/O (output on/off, sequence control and others)
- USB interface
- Store / Recall memories (30 sets)
- Power input: Three-phase, 3-wire or three-phase, 4-wire (specify on order, BP4640 to BP46100)

Topics

Evaluation of three-phase motor inverter

The introduction of a simulation system for a three-phase motor inverter using a bipolar power supply.

- With CC and CV operation, 1 set of BP series allows to test both of inverters and motors.
- Four quadrants operation enables supply and absorption of power, corresponding to motor power running and regeneration
- Fast response
- Configure 3 phases with 3 units

For motor simulation [Constant current operation]

A high-speed motor simulation system that combines a motor HILS and bipolar power supplies instead of the actual motor for various evaluations of motor drive inverters.

Point

- Constant current operation to simulate motor power consumption
- It is possible to simulate the power running and regeneration of the motor

For inverter simulation [Constant voltage operation]

The combination of a three-phase signal source and bipolar power supplies simulates the operation of the inverter. Supports complex evaluation tests of three-phase motors.

Point

- Constant voltage operation to simulate the output of an inverter
- Corresponds to motor regenerative power
- Complex tests such as rated operation, unbalanced three-phase operation and efficiency evaluation are possible

∨The internal signal source cannot be used in the above simulation system.

Motor simulation system

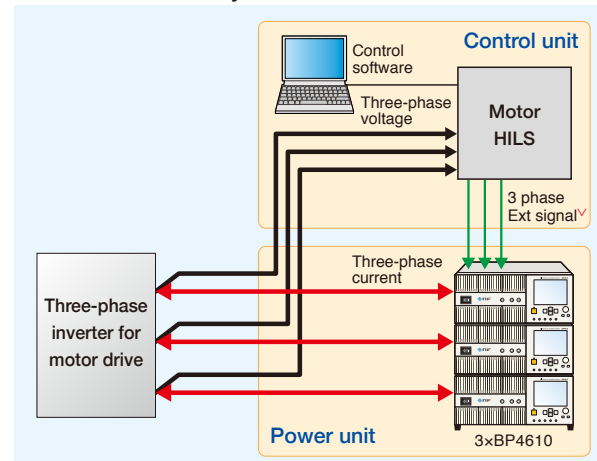

Inverter simulation system

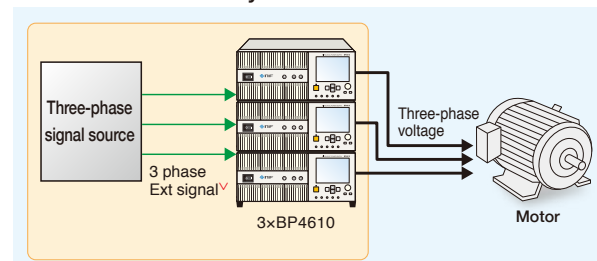

◆ **Note:** The common potential of the three-phase external signal must be isolated from the ground potential and each phase must be isolated from each other. Consult us before building a three-phase system.

APPLICATION

For power supply voltage fluctuation test on 12V/24V/48V vehicle electrical and electronic components

With BP series, you can perform power supply voltage fluctuation test on various vehicle electrical and electronic components. You can program a certain pattern in advance using the sequence function.

BP series handles the test on not only 12 V/24 V components but 48 V components.

Automotive Components

- Steering motor
- ECU power supply circuit
- Automotive electronics
- Electric pump (Water pump / Oil pump)
- Comprehensive test in-vehicle

Automotive Devices

- Power inductor
- Solenoid
- Connector
- High-power relay

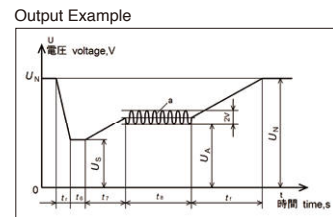
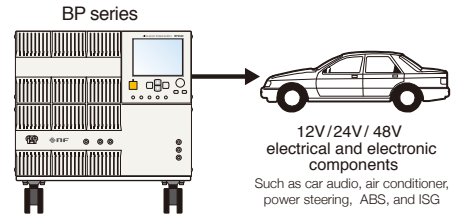

ISO 16750-2 Supply Voltage profile

As a constant current power supply for generating magnetic field

In electromagnetic field test, constant current needs to be supplied to the coil for stable generation of constant magnetic field. BP series can output constant current (CC) to keep the current running through the coil constant and generate stable magnetic field.

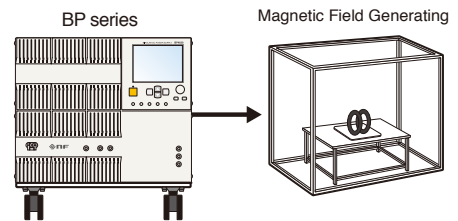

As a constant current power supply for capacitor ripple test

Using this power supply, you can perform ripple test on the units using capacitor(s) such as inverters. The constant current (CC) of BP series allows you to perform test with stable operation. You can also program output patterns using the sequence function

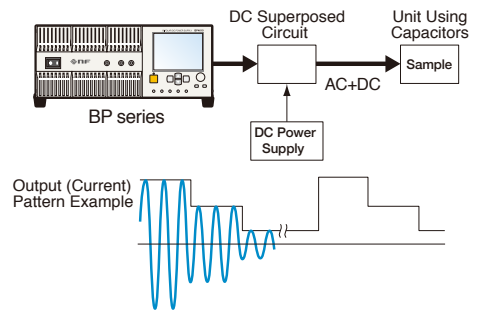

As a constant current power supply for plating

The power supply can be used as a constant current power supply for plating various electronic materials. Using the constant current (CC) output of BP series, you can always supply constant and stable current.

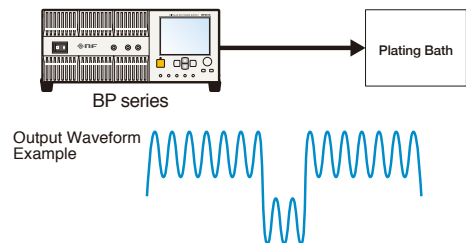

And other

Wireless Charging

- Power supply for charging
- Evaluation of charging coil

Driving of magnetic material

- Magnetic flux measurement
- B-H curve measurement

Specifications

[BP4610 / BP4620]

Output

Output voltage range	Any 120 Vp-p between -115 V and +115 V
Maximum output voltage CV mode* ¹ (R _L =Resistive load)	DC to 0.5 kHz : ±60 V (R _L = 6Ω ^{*2} / 3Ω ^{*3}) 0.5 kHz to 70 kHz : ±60 V (R _L =4Ω ^{*2} / 2Ω ^{*3}) 70 kHz to 150 kHz : ±50 V (R _L = 6Ω ^{*2} / 3Ω ^{*3})
Maximum output current CC mode* ¹ (R _L =Resistive load)	DC to 0.5 kHz : ±10 A ^{*2} / ±20 A ^{*3} (R _L = 6Ω ^{*2} / 3Ω ^{*3}) 0.5 kHz to 30 kHz : ±15 A ^{*2} / ±30 A ^{*3} (R _L = 4Ω ^{*2} / 2Ω ^{*3}) 30 kHz to 70 kHz : ±8.3 A ^{*2} / ±16.6 A ^{*3} (R _L = 6Ω ^{*2} / 3Ω ^{*3})
Small amplitude frequency characteristics* ¹	CV mode : DC to 200 kHz (amplitude 12 Vp-p) CC mode : DC to 70kHz (amplitude 12 Vp-p)
Response calibration function	Response characteristics can be adjusted with knobs on the front panel (Time constant: T, Voltage: V, and Current: I)
Rise / Fall time* ¹	CV mode : 2.5 μs (square ±60 V) CC mode : 4 μs(square ±10 A ^{*2} / ±20 A ^{*3})
Output impedance* ¹	CV mode : 7 mΩ+1.3 μH ^{*2} / 3.5 mΩ+0.65 μH ^{*3} CC mode : 10 kΩ//0.45 μF ^{*2} / 5 kΩ//0.90 μF ^{*3}
Output voltage limiter	+ voltage setting range : +7 V to +117 V (resolution 0.1 V) - voltage setting range : -7 V to -117 V (resolution 0.1 V) (The difference between the + voltage and the - voltage setting is restricted to 24 V or higher and 124 V or lower.)
Output current limiter	+ current setting range : +1 A to +26 A ^{*2} / +2 to +52 A ^{*3} (resolution 0.1 A) - current setting range : -1 A to -26 A ^{*2} / -2 to +52A ^{*3} (resolution 0.1 A)
Residual noise	CV mode : 50 mVrms or lower CC mode : 8 mArms or lower (The input terminal is shorted. 10 Hz to 300 kHz)

Signal Sources

Selectable from among internal source, external signal, and internal source + external signal.

Internal signal source	DC	Amplitude setting range : CV mode ±115 V (resolution 0.01 V) CC mode ±10 A ^{*2} (resolution 0.001 A) ±20 A ^{*3} (resolution 0.001 A)
	Superimposed AC	Waveform : Sine, Square, Arbitrary (16 types) Frequency setting range : 1 Hz to 100 kHz (resolution 0.1 Hz) Amplitude setting range : CV mode 0 to 120 Vp-p (resolution 0.1 Vp-p) CC mode 0 to 30 Ap-p ^{*2} (resolution 0.01 Ap-p) 0 to 60 Ap-p ^{*3} (resolution 0.01 Ap-p)
External signal input		Frequency range : DC to 200 kHz Gain : CV mode 100 times (100V / 1V), In phase CC mode 10 times (10 A / 1 V) ^{*2} , In phase 20 times (20 A / 1 V) ^{*3} , In phase

Sequence Function

Number of sequences	1 sequence for each of the CV mode and CC mode	
Number of steps	1 to 255 (within 1 sequence)	
Step time	0.1 ms to 999.9999 s (resolution 0.1 ms)	
Operation within each steps	Constant or linear sweep	
Parameters	CV mode	DC voltage, Superimposed AC voltage, Frequency, Waveform, Step sync output 2 bits
	CC mode	DC current, Superimposed AC current, Frequency, Waveform, Step sync output 2 bits
Jump count	1 to 999, or continuous	
Sequence control	Start	Start the sequence.
	Stop	Stop the sequence.
	Hold	Maintains settings at that point. The operation resumes at sequence start.
	Branch	Branches to the specified step.

Others

Monitor output	Voltage, Current
Measurement functions	DC output voltage, DC output current, AC output voltage, AC output current
Arbitrary waveform memory	16 (1024 words, 16 bit.) Write is performed via the USB interface.
Store / Recall memory	The basic settings can be saved to memories No. 1 to No. 30
Protective functions	If Output voltage over, output current over, internal output loss, Power supply anomaly, Internal overheating and operation panel anomaly are detected, the protective function works.
Interface	USB (USBTMC / USB488,USB1.1)
Other function	Output ON / OFF function, external control input / output, key lock, beep, reset, self-diagnosis function
Power input	BP4610 : 100 V to 230 V ±10% 250 V or lower BP4620 : 200 V to 230 V ±10% 50 Hz / 60 Hz ± 2%
Power consumption/ Power factor	BP4610 : Maximum of 1200 VA, Power factor 0.95 (at AC 100 V) BP4620 : Maximum of 2400 VA, Power factor 0.93 (at AC 200 V)
Ambient temperature / Humidity range	Performance Guarantee : +5 to +35°C / 5 to 85%RH with absolute humidity of 1 to 25g/m ³ and no condensation Storing Conditions : -10 to +50°C / 5 to 95%RH with absolute humidity of 1 to 29g / m ³ and no condensation
Dimensions (W×H×D)(mm)	BP4610 : 430(W) × 176(H) × 551(D) (No protrusions) BP4620 : 430(W) × 354(H) × 551(D) (No protrusions)
Weight (Approx.)	BP4610 : 26 kg BP4620 : 53 kg
Accessory	Manual, CD-ROM, Ferrite core (for USB cable) , Power code set

*¹ Typical values. These vary depending on the adjustment with the response calibration function. *² BP4610 *³ BP4620

[BP4630 / BP4640 / BP4650 / BP4660 / BP4670 / BP4680 / BP4690 / BP46100]

Output

*Adjusted characteristics R_L: Resistive load

Maximum output voltage* CV mode				
DC	+115 V (set + Vo limit to 117 V and - Vo limit to -7 V) -115 V (set + Vo limit to 7 V and - Vo limit to -117 V)			
	BP4630	BP4640	BP4650	BP4660
	RL=7.7 Ω	RL=5.8 Ω	RL=4.6 Ω	RL=3.8 Ω
	BP4670	BP4680	BP4690	BP46100
	RL=3.3 Ω	RL=2.9 Ω	RL=2.6 Ω	RL=2.3 Ω
DC to 0.5 kHz	±60 V			
	BP4630	BP4640	BP4650	BP4660
	RL=2.0 Ω	RL=1.5 Ω	RL=1.2 Ω	RL=1.0 Ω
	BP4670	BP4680	BP4690	BP46100
	RL=0.86 Ω	RL=0.75 Ω	RL=0.67 Ω	RL=0.60 Ω
0.5 kHz to 40 kHz	±60 V			
	BP4630	BP4640	BP4650	BP4660
	RL=1.3 Ω	RL=1.0 Ω	RL=0.80 Ω	RL=0.67 Ω
	BP4670	BP4680	BP4690	BP46100
	RL=0.57 Ω	RL=0.50 Ω	RL=0.44 Ω	RL=0.40 Ω
40 kHz to 150 kHz	±50 V			
	BP4630	BP4640	BP4650	BP4660
	RL=2.0 Ω	RL=1.5 Ω	RL=1.2 Ω	RL=1.0 Ω
	BP4670	BP4680	BP4690	BP46100
	RL=0.86 Ω	RL=0.75 Ω	RL=0.67 Ω	RL=0.60 Ω

Maximum output current* CC mode

DC to 0.5 kHz	BP4630	BP4640	BP4650	BP4660
	±30 A	±40 A	±50 A	±60 A
	RL=2.0 Ω	RL=1.5 Ω	RL=1.2 Ω	RL=1.0 Ω
	BP4670	BP4680	BP4690	BP46100
	±70 A	±80 A	±90 A	±100 A
	RL=0.86 Ω	RL=0.75 Ω	RL=0.67 Ω	RL=0.60 Ω
0.5 kHz to 30 kHz	BP4630	BP4640	BP4650	BP4660
	±45 A	±60 A	±75 A	±90 A
	RL=1.3 Ω	RL=1.0 Ω	RL=0.80 Ω	RL=0.67 Ω
	BP4670	BP4680	BP4690	BP46100
	±105 A	±120 A	±135 A	±150 A
	RL=0.57 Ω	RL=0.50 Ω	RL=0.44 Ω	RL=0.40 Ω
30 kHz to 70 kHz	BP4630	BP4640	BP4650	BP4660
	±24.9 A	±33.2 A	±41.5 A	±49.8 A
	RL=2.0 Ω	RL=1.5 Ω	RL=1.2 Ω	RL=1.0 Ω
	BP4670	BP4680	BP4690	BP46100
	±58.1 A	±66.4 A	±74.7 A	±83 A
	RL=0.86 Ω	RL=0.75 Ω	RL=0.67 Ω	RL=0.60 Ω

Small amplitude frequency characteristics*	CV mode : BP4630 to BP4650 : DC to 200 kHz (amplitude 12 Vp-p, 500 Hz reference) BP4660 to BP46100 : DC to 170kHz (amplitude 12 Vp-p, 500 Hz reference) CC mode : DC to 70kHz (amplitude 12 Vp-p, 500 Hz reference)																																																
Response calibration function	Response characteristics can be adjusted with knobs on the front panel (Time constant: T, Voltage: V, and Current: I)																																																
Rise / Fall time	CV mode BP4630 to BP4650 : 2.5 μ s (adjusted, square \pm 60 V) BP4660 to BP46100 : 2.7 μ s (adjusted, square \pm 60 V) CC mode BP4630 to BP4650 : 4 μ s (adjusted, square, for the following current) BP4660 to BP46100 : 4.2 μ s (adjusted, square, for the following current) <table border="1"> <tr> <td>BP4630</td> <td>BP4640</td> <td>BP4650</td> <td>BP4660</td> </tr> <tr> <td>\pm30 A</td> <td>\pm40 A</td> <td>\pm50 A</td> <td>\pm60 A</td> </tr> <tr> <td>BP4670</td> <td>BP4680</td> <td>BP4690</td> <td>BP46100</td> </tr> <tr> <td>\pm70 A</td> <td>\pm80 A</td> <td>\pm90 A</td> <td>\pm100 A</td> </tr> </table>	BP4630	BP4640	BP4650	BP4660	\pm 30 A	\pm 40 A	\pm 50 A	\pm 60 A	BP4670	BP4680	BP4690	BP46100	\pm 70 A	\pm 80 A	\pm 90 A	\pm 100 A																																
BP4630	BP4640	BP4650	BP4660																																														
\pm 30 A	\pm 40 A	\pm 50 A	\pm 60 A																																														
BP4670	BP4680	BP4690	BP46100																																														
\pm 70 A	\pm 80 A	\pm 90 A	\pm 100 A																																														
Output impedance	CV mode* : <table border="1"> <tr> <td>BP4630</td> <td>BP4640</td> <td>BP4650</td> <td>BP4660</td> </tr> <tr> <td>2.3 mΩ+</td> <td>1.8 mΩ+</td> <td>1.4 mΩ+</td> <td>1.2 mΩ+</td> </tr> <tr> <td>0.43 μH</td> <td>0.33 μH</td> <td>0.31 μH</td> <td>0.3 μH</td> </tr> <tr> <td>BP4670</td> <td>BP4680</td> <td>BP4690</td> <td>BP46100</td> </tr> <tr> <td>1 mΩ+</td> <td>0.9 mΩ+</td> <td>0.8 mΩ+</td> <td>0.7 mΩ+</td> </tr> <tr> <td>0.29 μH</td> <td>0.27 μH</td> <td>0.26 μH</td> <td>0.24 μH</td> </tr> </table> CC mode* : <table border="1"> <tr> <td>BP4630</td> <td>BP4640</td> <td>BP4650</td> <td>BP4660</td> </tr> <tr> <td>3.3 kΩ//</td> <td>2.5 kΩ//</td> <td>2 kΩ//</td> <td>1.7 kΩ//</td> </tr> <tr> <td>1.35 μF</td> <td>1.8 μF</td> <td>2.25 μF</td> <td>2.7 μF</td> </tr> <tr> <td>BP4670</td> <td>BP4680</td> <td>BP4690</td> <td>BP46100</td> </tr> <tr> <td>1.4 kΩ//</td> <td>1.3 kΩ//</td> <td>1.1 kΩ//</td> <td>1 kΩ//</td> </tr> <tr> <td>3.15 μF</td> <td>3.6 μF</td> <td>4.05 μF</td> <td>4.5 μF</td> </tr> </table>	BP4630	BP4640	BP4650	BP4660	2.3 m Ω +	1.8 m Ω +	1.4 m Ω +	1.2 m Ω +	0.43 μ H	0.33 μ H	0.31 μ H	0.3 μ H	BP4670	BP4680	BP4690	BP46100	1 m Ω +	0.9 m Ω +	0.8 m Ω +	0.7 m Ω +	0.29 μ H	0.27 μ H	0.26 μ H	0.24 μ H	BP4630	BP4640	BP4650	BP4660	3.3 k Ω //	2.5 k Ω //	2 k Ω //	1.7 k Ω //	1.35 μ F	1.8 μ F	2.25 μ F	2.7 μ F	BP4670	BP4680	BP4690	BP46100	1.4 k Ω //	1.3 k Ω //	1.1 k Ω //	1 k Ω //	3.15 μ F	3.6 μ F	4.05 μ F	4.5 μ F
BP4630	BP4640	BP4650	BP4660																																														
2.3 m Ω +	1.8 m Ω +	1.4 m Ω +	1.2 m Ω +																																														
0.43 μ H	0.33 μ H	0.31 μ H	0.3 μ H																																														
BP4670	BP4680	BP4690	BP46100																																														
1 m Ω +	0.9 m Ω +	0.8 m Ω +	0.7 m Ω +																																														
0.29 μ H	0.27 μ H	0.26 μ H	0.24 μ H																																														
BP4630	BP4640	BP4650	BP4660																																														
3.3 k Ω //	2.5 k Ω //	2 k Ω //	1.7 k Ω //																																														
1.35 μ F	1.8 μ F	2.25 μ F	2.7 μ F																																														
BP4670	BP4680	BP4690	BP46100																																														
1.4 k Ω //	1.3 k Ω //	1.1 k Ω //	1 k Ω //																																														
3.15 μ F	3.6 μ F	4.05 μ F	4.5 μ F																																														
Output voltage limiter	+voltage setting range +7 V to +117 V (initial : +62 V, resolution 0.1 V) -voltage setting range -117 V to -7 V (initial : -62 V, resolution 0.1 V) Note : The difference between the + voltage and the - voltage setting is restricted to 24 V or higher and 124 V or lower.																																																
Output current limiter	+current setting range <table border="1"> <tr> <td>BP4630</td> <td>BP4640</td> <td>BP4650</td> <td>BP4660</td> </tr> <tr> <td>+3 A to +78 A</td> <td>+4 A to +104 A</td> <td>+5 A to +130 A</td> <td>+6 A to +156 A</td> </tr> <tr> <td>BP4670</td> <td>BP4680</td> <td>BP4690</td> <td>BP46100</td> </tr> <tr> <td>+7A to +182 A</td> <td>+8 A to +208 A</td> <td>+9 A to +234 A</td> <td>+10 A to +260 A</td> </tr> </table> -current setting range <table border="1"> <tr> <td>BP4630</td> <td>BP4640</td> <td>BP4650</td> <td>BP4660</td> </tr> <tr> <td>-78A to -3A</td> <td>-104A to -4A</td> <td>-130A to -5A</td> <td>-156 A to -6A</td> </tr> <tr> <td>BP4670</td> <td>BP4680</td> <td>BP4690</td> <td>BP46100</td> </tr> <tr> <td>-182 A to -7A</td> <td>-208 A to -8A</td> <td>-234 A to -9A</td> <td>-260 A to -10A</td> </tr> </table>	BP4630	BP4640	BP4650	BP4660	+3 A to +78 A	+4 A to +104 A	+5 A to +130 A	+6 A to +156 A	BP4670	BP4680	BP4690	BP46100	+7A to +182 A	+8 A to +208 A	+9 A to +234 A	+10 A to +260 A	BP4630	BP4640	BP4650	BP4660	-78A to -3A	-104A to -4A	-130A to -5A	-156 A to -6A	BP4670	BP4680	BP4690	BP46100	-182 A to -7A	-208 A to -8A	-234 A to -9A	-260 A to -10A																
BP4630	BP4640	BP4650	BP4660																																														
+3 A to +78 A	+4 A to +104 A	+5 A to +130 A	+6 A to +156 A																																														
BP4670	BP4680	BP4690	BP46100																																														
+7A to +182 A	+8 A to +208 A	+9 A to +234 A	+10 A to +260 A																																														
BP4630	BP4640	BP4650	BP4660																																														
-78A to -3A	-104A to -4A	-130A to -5A	-156 A to -6A																																														
BP4670	BP4680	BP4690	BP46100																																														
-182 A to -7A	-208 A to -8A	-234 A to -9A	-260 A to -10A																																														

Signal Sources

Selectable from among internal source, external signal, and internal source + external signal.

Internal signal source																		
CV mode																		
DC voltage setting range	-115 to +115 V (resolution 0.01 V)																	
AC voltage	Amplitude setting range	0 Vp-p to 120 Vp-p (resolution 0.1 Vp-p)																
	Waveform	Sine, Square, Arbitrary (16 types)																
	Frequency setting range	1 Hz to 100 kHz (resolution 0.1 Hz)																
CC mode																		
DC current	Setting range	<table border="1"> <tr> <td>BP4630</td> <td>BP4640</td> <td>BP4650</td> <td>BP4660</td> </tr> <tr> <td>-30 A to +30 A</td> <td>-40 A to +40 A</td> <td>-50 A to +50 A</td> <td>-60 A to +60 A</td> </tr> <tr> <td>BP4670</td> <td>BP4680</td> <td>BP4690</td> <td>BP46100</td> </tr> <tr> <td>-70 A to +70 A</td> <td>-80 A to +80 A</td> <td>-90 A to +90 A</td> <td>-100 A to +100 A</td> </tr> </table>	BP4630	BP4640	BP4650	BP4660	-30 A to +30 A	-40 A to +40 A	-50 A to +50 A	-60 A to +60 A	BP4670	BP4680	BP4690	BP46100	-70 A to +70 A	-80 A to +80 A	-90 A to +90 A	-100 A to +100 A
	BP4630	BP4640	BP4650	BP4660														
-30 A to +30 A	-40 A to +40 A	-50 A to +50 A	-60 A to +60 A															
BP4670	BP4680	BP4690	BP46100															
-70 A to +70 A	-80 A to +80 A	-90 A to +90 A	-100 A to +100 A															
Resolution	0.01A																	
AC current	Amplitude setting range	<table border="1"> <tr> <td>BP4630</td> <td>BP4640</td> <td>BP4650</td> <td>BP4660</td> </tr> <tr> <td>0 Ap-p to 90 Ap-p</td> <td>0 Ap-p to 120 Ap-p</td> <td>0 Ap-p to 150 Ap-p</td> <td>0 Ap-p to 180 Ap-p</td> </tr> <tr> <td>BP4670</td> <td>BP4680</td> <td>BP4690</td> <td>BP46100</td> </tr> <tr> <td>0 Ap-p to 210 Ap-p</td> <td>0 Ap-p to 240 Ap-p</td> <td>0 Ap-p to 270 Ap-p</td> <td>0 Ap-p to 300 Ap-p</td> </tr> </table>	BP4630	BP4640	BP4650	BP4660	0 Ap-p to 90 Ap-p	0 Ap-p to 120 Ap-p	0 Ap-p to 150 Ap-p	0 Ap-p to 180 Ap-p	BP4670	BP4680	BP4690	BP46100	0 Ap-p to 210 Ap-p	0 Ap-p to 240 Ap-p	0 Ap-p to 270 Ap-p	0 Ap-p to 300 Ap-p
	BP4630	BP4640	BP4650	BP4660														
	0 Ap-p to 90 Ap-p	0 Ap-p to 120 Ap-p	0 Ap-p to 150 Ap-p	0 Ap-p to 180 Ap-p														
	BP4670	BP4680	BP4690	BP46100														
	0 Ap-p to 210 Ap-p	0 Ap-p to 240 Ap-p	0 Ap-p to 270 Ap-p	0 Ap-p to 300 Ap-p														
Resolution	0.1 Ap-p																	
Waveform	Sine, Square, Arbitrary (16 types)																	
Frequency setting range	1 Hz to 100 kHz (resolution 0.1 Hz)																	
External signal input																		
Phase	In phase																	
Input impedance	10 k Ω																	
Non-destructive max. input voltage	\pm 5 V																	
Frequency range	DC to 200 kHz																	
Gain	CV mode : 100																	
	CC mode : <table border="1"> <tr> <td>BP4630</td> <td>BP4640</td> <td>BP4650</td> <td>BP4660</td> </tr> <tr> <td>30 A / V</td> <td>40 A / V</td> <td>50 A / V</td> <td>60 A / V</td> </tr> <tr> <td>BP4670</td> <td>BP4680</td> <td>BP4690</td> <td>BP46100</td> </tr> <tr> <td>70 A / V</td> <td>80 A / V</td> <td>90 A / V</td> <td>100 A / V</td> </tr> </table>	BP4630	BP4640	BP4650	BP4660	30 A / V	40 A / V	50 A / V	60 A / V	BP4670	BP4680	BP4690	BP46100	70 A / V	80 A / V	90 A / V	100 A / V	
BP4630	BP4640	BP4650	BP4660															
30 A / V	40 A / V	50 A / V	60 A / V															
BP4670	BP4680	BP4690	BP46100															
70 A / V	80 A / V	90 A / V	100 A / V															

Sequence Function

Number of sequences	1 sequence for each of the CV mode and CC mode	
Number of steps	1 to 255 (within 1 sequence)	
Step time	0.1 ms to 999.9999 s (resolution 0.1 ms)	
Operation within each steps	Constant or linear sweep	
Parameters	CV mode	DC voltage, Superimposed AC voltage, Frequency, Waveform, Step sync output 2 bits
	CC mode	DC current, Superimposed AC current, Frequency, Waveform, Step sync output 2 bits
Jump count	1 to 999, or continuous	
Sequence control	Start	Start the sequence.
	Stop	Stop the sequence.
	Hold	Maintains settings at that point. The operation resumes at sequence start.
	Branch	Branches to the specified step.

Others

Monitor output	Voltage, Current			
Measurement functions	DC output voltage, DC output current, AC output voltage, AC output current			
Arbitrary waveform memory	16 (1024 words, 16 bit.) Write is performed via the USB interface.			
Store / Recall memory	The basic settings can be saved to memories No. 1 to No. 30			
Protective functions	If Output voltage over, output current over, internal output loss, Power supply anomaly, Internal overheating and operation panel anomaly are detected, the protective function works.			
Interface	USB (USBTMC / USB488,USB1.1)			
Other function	Output ON / OFF function, external control input / output, key lock, beep, reset, self-diagnosis function			
Power input	BP4630: single-phase 180 V to 250 V, 50 Hz/60 Hz \pm 2 Hz BP4640 to BP46100 (specify on order): three-phase, 3-wire 180 V to 250 V or three-phase, 4-wire 323 V to 433 V 50 Hz/60 Hz \pm 2 Hz			
Power factor (Approx.)	0.93			
Power consumption	BP4630	BP4640	BP4650	BP4660
	3.6 kVA	4.8 kVA	6 kVA	7.2 kVA
	BP4670	BP4680	BP4690	BP46100
	8.4 kVA	9.6 kVA	10.8 kVA	12 kVA
Dimensions (WxHxD)(mm)	BP4630 : 430(W) \times 710(H) \times 686(D) BP4640 / BP4650 : 505(W) \times 1150(H) \times 700(D) BP4660 to BP46100 : 995(W) \times 1150(H) \times 700(D)			
Weight (Approx.)	BP4630	BP4640	BP4650	BP4660
	97 kg	165 kg	180 kg	260 kg
	BP4670	BP4680	BP4690	BP46100
	280 kg	300 kg	320 kg	340 kg
EMC (Excluding BP4630)	KN 11 (Group 1, Class A) KN 61000-6-2			
Accessory	Manual, CD-ROM, Ferrite core (for USB cable)			

Option

- PA-001-3019 : Rack mount adapter (for EIA BP4630)
- PA-001-3020 : Rack mount adapter (for JIS BP4630)
- PA-001-3021 : Replacement air filter 1 (for BP4630)
- PA-001-3022 : Replacement air filter 2 (for BP4630)
- PA-001-3023 : Replacement air filter 1S (for BP4640/4650/4660/4670/4680/4690/46100)
- PA-001-3024 : Replacement air filter 2S (for BP4640/4650/4660/4670/4680/4690/46100)
- PA-001-3025 : Replacement air filter W (for BP4660/4670/4680/4690/46100)
- PA-001-3026 : Fixing Bracket (for BP4630)
- PA-001-3027 : Fixing Bracket (for BP4640/BP4650)
- PA-001-3028 : Fixing Bracket (BP4660/4670/4680/4690/46100)

MULTIFUNCTION GENERATOR WF1973 / WF1974

Effortless waveform generator via an intuitive graphical user interface

- Frequency range : 0.01 μ Hz to 30 MHz
- Sine, Square (duty variable), Pulse, Ramp wave, Noise, DC, Arbitrary waveforms
- Auto burst, trigger burst, gate, triggered gate
- Internal and external modulation, sweep
- Sequence function
- 2-channel operation (WF1974)

FREQUENCY RESPONSE ANALYZER FRA51615

From power electronics such as inverters and wireless charging to servo control, evaluation of electronic components and batteries

- Frequency range : 10 μ Hz to 15 MHz
- Measurement speed : 0.5 ms/point
- Basic accuracy : Gain : ± 0.01 dB, Phase : $\pm 0.06^\circ$
- Isolation : 600 V CATII / 300 V CATIII
- Maximum measurement voltage : 600 Vrms
- Sequence measurement function, Marker search, Load correction, Port extension.

GAIN-PHASE ANALYZER FRA51602

Loop-gain measurement for inverters and switching power supply

- Frequency range : 10 μ Hz to 2 MHz
- Measurement speed : 0.5 ms/point
- Basic accuracy : Gain : ± 0.01 dB, Phase: $\pm 0.06^\circ$
- Maximum input voltage / Isolation : 600 V CAT II / 300 V CAT III
- Maximum measurement voltage : 600 Vrms
- Dynamic range : 140 dB
- Sequence measurement function, Auto ranging, Amplitude compression function, Equalization.

Note: The contents of this catalog are current as of April 12, 2021.
Product appearance and specifications are subject to change without notice.
Before purchase, contact us to confirm the latest specifications, price and delivery date.

NF Corporation

Head Office
6-3-20 Tsunashima Higashi, Kohoku-ku, Yokohama 223-8508, Japan
<http://www.nfcorp.co.jp/english/>

NF Techno Commerce Co., Ltd.

International Sales Division
6-3-14 Tsunashima Higashi, Kohoku-ku, Yokohama 223-0052, Japan
Phone : +81-45-777-7604 Fax : +81-45-777-7605

Aufgrund laufender Weiterentwicklungen sind Änderungen der Spezifikationen vorbehalten. Alle Angaben vorbehaltlich Satz- und Druckfehler.

v01.08.22