

MODEL 2500E

500 LBF ELECTRODYNAMIC EXCITER

- Forced air cooling sufficient to meet full shaker performance (500 lbf / 2.2 kN) specifications
- Large 6 in (152 mm) specimen mounting table offers ease of mounting
- 1.0 in (25.4 mm) stroke and wide frequency range (to 4500 Hz) support broad range of applications
- Trunnion base provides flexibility when choosing best exciter location
- Low stray magnetic field, minimized by built-in degauss coil

APPLICATIONS

- Vibration testing of
 - Avionics
 - CubeSat Satellites
 - Consumer products
 - Automotive parts, electronics
 - Mechanical subassemblies

VERSATILE VIBRATION TESTING

The Modal Shop's Electrodynamic Shaker Model 2500E is a 500 lbf pk sine force shaker designed for general-purpose vibration testing of small components, as well as stress screening of electronic and mechanical sub-assemblies. It is designed to re-create field vibration in a controlled laboratory setting and can be used in a variety of R&D, reliability, and quality assurance applications within the automotive, aerospace & defense, and consumer electronics sectors.

Model 2500E offers a large 6 in (152 mm) diameter specimen mounting table, making it easy to adapt to almost any test requirement with a minimum of fixturing. The table provides multiple internally threaded attachment points, making the shaker assembly ideally suited for applications such as production screening, reliability acceptance testing, and product engineering evaluation. The composite materials used for the armature suspension and guidance system provide a high degree of lateral and rotational restraint while maintaining maximum compliance in the axis of motion to permit full 1.0 in (25 mm) peak to peak stroke. The shaker and trunnion base assembly allow a variety of operating positions ranging from a standard vertical orientation to a rotation of 90° to interface with horizontal tables.

Model 2500E has an inherently low stray magnetic field, which is minimized even further by the use of a built-in degauss coil. Safety features include over travel switch protection, air-cooling flow interlocks, and safe start in mute mode associated with the Model 2050E12-7 Digital Power Amplifier. Optional accessories are available such as special vibration isolation mounts, metric inserts for specimen mounting, and a magnesium head expander.

modalshop.com/excitation | 1 513 351 9919

SPECIFICATIONS

Performance

Output Force, sine pk, forced air cooling	500 lbf (2.2 kN) ^[1]
Output Force, random RMS, forced air cooling	350 lbf (1.6 kN) ^[1]
Output Force, shock pk	1000 lbf (4.4 kN) ^[1]
Stroke Length, continuous pk-pk	1.0 in (25.4 mm)
Stroke Length, between stops	1.2 in (30.5 mm)
Frequency Range, nominal	DC – 4500 Hz ^[2]
Fundamental Resonance	> 3300 Hz ^[2]
Maximum Velocity	140 in/s pk (356 cm/s pk)
Maximum Acceleration, bare table	100 g pk
Maximum Acceleration, resonance	150 g pk
Maximum Acceleration, pulse shock	300 g pk

Physical

Platform Mounting Thread	5x 1/4-20 ^[3]
Armature Weight	5 lb (2.268 kg)
Suspension Stiffness (nominal)	250 lbf/in (43.8 N/mm)
Rated Drive Current, forced air cooling	40 A RMS
Stray Magnetic Field, 3.0 in (76.2 mm) above table	< 10 Gauss ^[4]
Stray Magnetic Field, 2.0 in (50.8 mm) from body	< 15 Gauss
Cooling Air	Air-cooled by suction type remote centrifugal blower with 12 ft. long flexible duct
Dimensions (H x W x D), nominal	21.0 x 14.5 x 14.0 in (533 x 368 x 356 mm) ^[5]
Weight, with trunnion	475 lb (215 kg)
Temperature Operating Range	40 – 100 °F (4 – 38 °C), < 85% RH
Field Supply	1 kW nominal

Supplied Accessories

Trunnion Base, 3/8 in Hex Wrench, 10 ft (3 m) Shaker Cable

Required Accessories (K2500E500 Shaker System)

2050E12-7	Power Amplifier, 3500 VA, field power supply, 200-240V, single phase
2000X12	Cooling Package

Optional Accessories

Magnesium Head Expander 12 x 12 in (305 x 305 mm)
Special Vibration Base Isolation Mounts (Solid 10 Hz, or Pneumatic 5 Hz)

[1] Full force range requires forced air cooling with 2050E12-7 power amplifier.

[2] Load dependent, stated specifications based upon bare table.

[3] Inserts also available with M6 x 1 threads.

[4] Field adjustable with degaussing coil.

[5] Reference outline drawing for details.

Front Left Photo Courtesy of Cal Poly CubeSat Laboratory

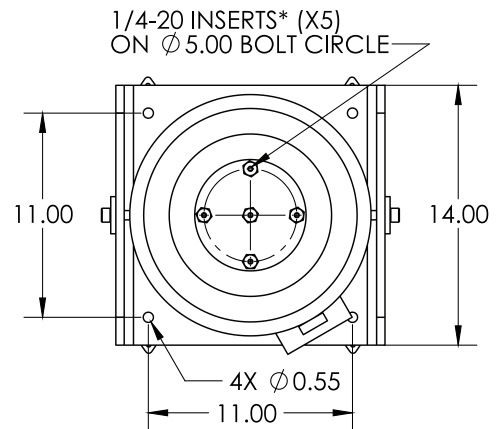

Model 2500E - Top View

Dimensions in inches

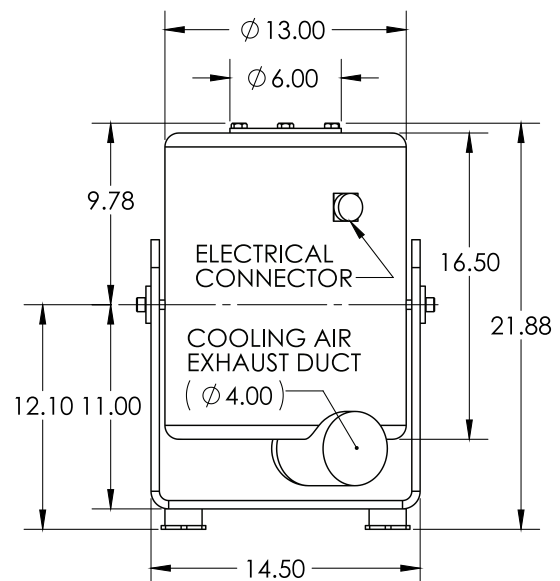

Model 2500E - Front View

Dimensions in inches



10310 Aerohub Boulevard, Cincinnati, OH 45215 USA

modalshop.com | info@modalshop.com | 800 860 4867 | +1 513 351 9919

© 2024 PCB Piezotronics - all rights reserved. PCB Piezotronics is a wholly-owned subsidiary of Amphenol Corporation. Endevo is an assumed name of PCB Piezotronics of North Carolina, Inc., which is a wholly-owned subsidiary of PCB Piezotronics, Inc. Accumetrics, Inc. and The Modal Shop, Inc. are wholly-owned subsidiaries of PCB Piezotronics, Inc. IMI Sensors and Larson Davis are Divisions of PCB Piezotronics, Inc. Except for any third party marks for which attribution is provided herein, the company names and product names used in this document may be the registered trademarks or unregistered trademarks of PCB Piezotronics, Inc., PCB Piezotronics of North Carolina, Inc. (d/b/a Endevo), The Modal Shop, Inc. or Accumetrics, Inc. Detailed trademark ownership information is available at www.pcb.com/trademarkownership. In the interest of constant product improvement, specifications are subject to change without notice.

DS-0250 revA

Aufgrund laufender Weiterentwicklungen sind Änderungen der Spezifikationen vorbehalten. Alle Angaben vorbehaltlich Satz- und Druckfehler.

nbn Austria GmbH

Riesstraße 146, 8010 Graz

+43 316 40 28 05

info@nbn.at | www.nbn.at

