

2404 STANDARD STAINLESS STEEL 2-WIRE AMPLIFIED LOAD CELL (U.S. & METRIC)

FEATURES & BENEFITS

- Capacities from 100 to 5K lbf (0.44 to 22.2 kN)
- Stainless steel construction
- Hermetically sealed
- Tension and compression
- Counterbored mounting holes
- Internally amplified with 4-20 mA output
- Proprietary Interface temperature compensated strain gages

STANDARD CONFIGURATION



Model 2424CSY-500 (shown)

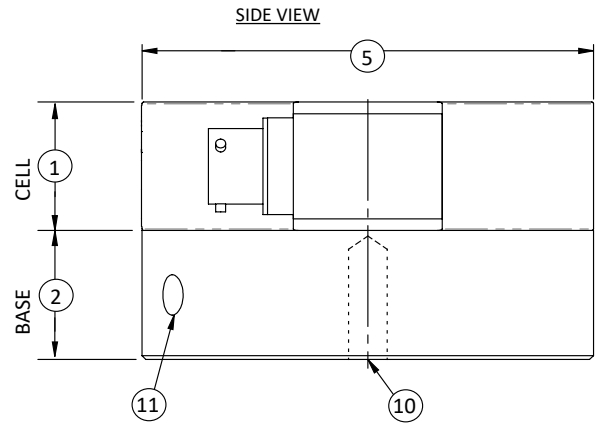
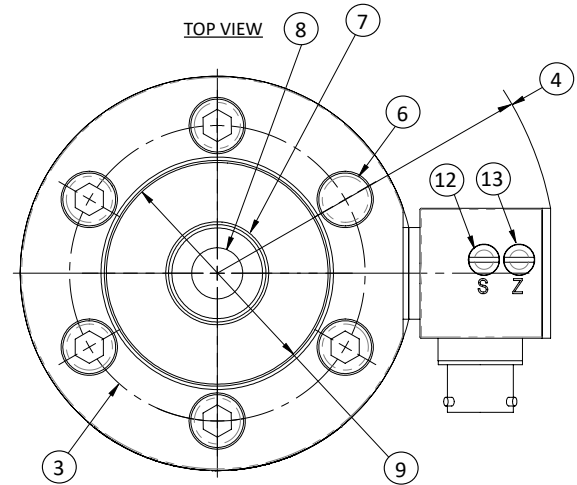

DIMENSIONS

See Drawing	MODEL			
	2424		2434	
	CAPACITY			
	U.S. (lbf)	Metric (kN)	U.S. (lbf)	Metric (kN)
	100, 250, 500, 1000	0.44, 1.11, 2.22, 4.45	2K, 5K	89, 22.2
	in	mm	in	mm
(1)	1	25.4	1	25.4
(2)	1	25.4	1	25.4
(3)	2.25	57.2	2.625	66.68
(4)	2.76	70.1	3.01	76.3
(5)	3	76.2	3.5	88.9
(6)	Counterbored for ¼-28 SHCS 6 Places		Counterbored for ¼-24 SHCS 6 Places	
(7)	0.55	14	0.81	20.5
(8)	¾-24 UNF-3B THRU		¾-20 UNF-3B THRU	
(9)	1.81	46	2.07	52.5
(10)	¾-24 UNF ↓ 0.70		¾-20 UNF ↓ 0.70	
(11)	(2) Spanner holes spaced at 180°			
(12)	Span adjust			
(13)	Zero adjust			

* Metric dimensions and capacities are provided for conversion only. Standard product will be sold in lbf and U.S. dimensions. Metric capacities available upon special request and at an additional cost.

2404 STANDARD STAINLESS STEEL 2-WIRE AMPLIFIED LOAD CELL (U.S. & METRIC)

SPECIFICATIONS

PARAMETERS		MODEL	
		2424	2434
		CAPACITY	
MEASURING RANGE	U.S. (lbf)	100, 250, 500, 1000	2K, 5K
	Metric (kN)	0.44, 1.11, 2.22, 4.45	89, 22.2
ACCURACY – (MAX ERROR)			
Nonlinearity – %FS		±0.10	±0.10
Hysteresis – %FS		±0.08	±0.08
Non-repeatability – %RO		±0.03	±0.03
Creep, in 20 min – %		±0.05	±0.05
TEMPERATURE			
Compensated Range	°F	+15 to +115	+15 to +115
	°C	-10 to +45	-10 to +45
Operating Range	°F	-20 to +200	-20 to +200
	°C	-30 to +93	-30 to +93
Effect on Zero – %RO / °F MAX		±0.005	±0.005
Effect on Output – %RO / °F MAX		±0.009	±0.009
ELECTRICAL *RATED OUTPUT mA			
*Tension or Compression (unipolar)		+16.000 ±0.032	
*Universal Tension (bipolar)		+8.000 ±0.016	
*Universal Compression (bipolar)		-8.000 ±0.016	
Zero Balance		4.000 ±0.100 (unipolar) 12.000 ±0.100 (bipolar)	
Zero Adjustment		1 mA range	
Span Adjustment		5% range	
Supply Voltage range – VDC		9-28	
Bandwidth Hz		2000	
MECHANICAL			
Safe Overload – %CAP		±150	
Deflection @ RO	in	100: 0.003, 250 THRU 5K: 0.002	
	mm	0.44: 0.076, 1.11 THRU 22.2 : 0.051	
Optional Base – P/N		B319-2	
Natural Frequency – kHz		1.3, 2.2, 4.4, 6.0, 8.3, 9.1, 11.7	
Material		Stainless steel	

OPTIONS

- Base (recommended)
- Transducer Electronic Data Sheet (TEDS)
- Custom calibration
- Special threads
- Special temperature range

CONNECTOR OPTIONS

- PTWIH-10-6P

ACCESSORIES

- Mating connector
- Instrumentation
- Loading hardware

* Metric dimensions and capacities are provided for conversion only. Standard product will be sold in lbf and U.S. dimensions. Metric capacities available upon special request and at an additional cost.

2404 STANDARD STAINLESS STEEL 2-WIRE AMPLIFIED LOAD CELL (U.S. & METRIC)

BAYONET CONNECTOR



Model 2424CSY-500

BASE

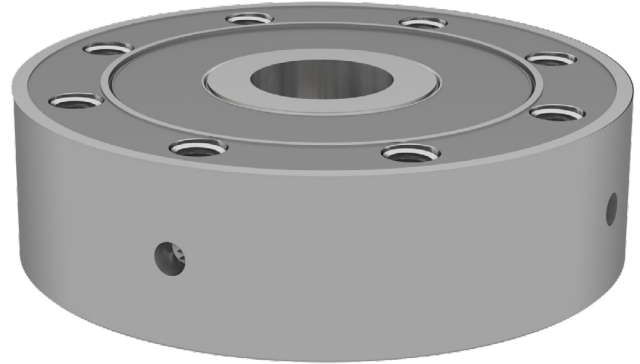

Model B24XX

