

## 2101 DUAL RANGE STANDARD LOAD CELL COMPRESSION-ONLY (U.S. & METRIC)

### FEATURES & BENEFITS

- Dual range allows for accurate measurements throughout test range
- 4X to 5X overload protection on lower capacity load cell
- Proprietary Interface temperature compensated gages
- High output for both ranges-to 4 mV/V
- Eccentric load compensated
- Shunt calibration
- Low deflection
- Lower capacity same as 1201 Compression-Only Low Profile
- Higher capacity same as 1200 Universal Low Profile

### OPTIONS

- Connector protection
- Standardized output
- Transducer Electronic Data Sheet (TEDS)
- Custom calibration
- Multiple bridge
- Special threads
- Dual diaphragm
- Special temperature range
- Cable length
- Add connector to cable

### CONNECTOR OPTIONS

- Integral cable (10 ft)
- PT02E-10-6P bayonet connector
- PC04E-10-6P screw-type connector

### STANDARD CONFIGURATION



Model 2121-10K/50K (Shown)

### ACCESSORIES

- Mating connector
- Mating cable
- Instrumentation

## 2101 DUAL RANGE STANDARD LOAD CELL COMPRESSION-ONLY (U.S. & METRIC)

### SPECIFICATIONS

PARAMETERS		MODEL				
		2111	2121	2131	2141	
		CAPACITY				
Measuring Range	U.S. (lbf)	1K/5K, 2K/10K	5K/25K, 10K/50K	25K/100K	50K/150K	100K/270K
	Metric (kN)	5/25, 10/50	25/100, 50/250	100/450	250/675	450/1200
<b>ACCURACY – (MAX ERROR)</b>						
Static Error Band – %FS		±0.03/±0.04	±0.04/±0.04	±0.04/±0.06	±0.04/±0.07	±0.04/±0.07
Nonlinearity – %FS		±0.03/±0.04	±0.04/±0.04	±0.05/±0.05	±0.05/±0.07	±0.05/±0.08
Hysteresis – %FS		±0.03/±0.04	±0.04/±0.05	±0.05/±0.06	±0.05/±0.07	±0.05/±0.08
Nonrepeatability – %RO		±0.01/±0.01	±0.01/±0.01	±0.01/±0.01	±0.01/±0.01	±0.01/±0.02
Creep, in 20 min – %		±0.025/±0.025	±0.025/±0.025	±0.025/±0.025	±0.025/±0.025	±0.025/±0.025
Side Load Sensitivity – %		±0.25/±0.25	±0.25/±0.25	±0.25/±0.25	±0.25/±0.25	±0.25/±0.25
Eccentric Load Sensitivity – %/in		±0.25/±0.25	±0.25/±0.25	±0.25/±0.25	±0.25/±0.25	±0.25/±0.25
<b>TEMPERATURE</b>						
Compensated Range	°F	+15 to +115/+15 to +115	+15 to +115/+15 to +115	+15 to +115/+15 to +115	+15 to +115/+15 to +115	+15 to +115/+15 to +115
	°C	-10 to +45/-10 to +45	-10 to +45/-10 to +45	-10 to +45/-10 to +45	-10 to +45/-10 to +45	-10 to +45/-10 to +45
Operating Range	°F	-65 to +200/-65 to +200	-65 to +200/-65 to +200	-65 to +200/-65 to +200	-65 to +200/-65 to +200	-65 to +200/-65 to +200
	°C	-55 to +90/-55 to +90	-55 to +90/-55 to +90	-55 to +90/-55 to +90	-55 to +90/-55 to +90	-55 to +90/-55 to +90
Effect on Zero – %RO MAX	°F	±0.0008/±0.0008	±0.0008/±0.0008	±0.0008/±0.0008	±0.0008/±0.0008	±0.0008/±0.0008
	°C	±0.0015/±0.0015	±0.0015/±0.0015	±0.0015/±0.0015	±0.0015/±0.0015	±0.0015/±0.0015
Effect on Output – %RO/°F MAX	°F	±0.0008/±0.0008	±0.0008/±0.0008	±0.0008/±0.0008	±0.0008/±0.0008	±0.0008/±0.0008
	°C	±0.0015/±0.0015	±0.0015/±0.0015	±0.0015/±0.0015	±0.0015/±0.0015	±0.0015/±0.0015
<b>ELECTRICAL</b>						
Rated Output – mV/V (Nominal)		2.0/4.0	4.0/4.0	4.0/4.0	4.0/4.0	4.0/4.0
Excitation Voltage – VDC MAX		20/20	20/20	20/20	20/20	20/20
Bridge Resistance – Ohm (Nominal)		350/350	350/350	350/350	350/350	350/350
Zero Balance – %RO		±1.0/±1.0	±1.0/±1.0	±1.0/±1.0	±1.0/±1.0	±1.0/±1.0
Insulation Resistance – Megohm		5000/5000	5000/5000	5000/5000	5000/5000	5000/5000
<b>MECHANICAL</b>						
Safe Overload – %CAP		±150*	±150*	±150*	±150*	±150*
Deflection @ RO	in	0.001/0.002	0.002/0.002	0.002/0.003	0.002/0.012	0.003/0.006
	mm	0.03/0.05	0.05/0.05	0.05/0.08	0.05/0.30	0.08/0.15
Optional Base – P/N (Metric)		B101/B102 (M)	B102/B103 (M)	B106/B112 (M)	B106/B105 (M)	B104/B116 (M)
Natural Frequency – kHz		6.4, 9.0/6.6, 9.4	6.1, 8.6/ 6.5, 7.0	8.2, 11.7/5.8	8.2, 11.7/4.9	7.6/5.0
Weight	lbs	1.5/3.33	3.3/9.5	6.8/26	6.8/68	13.5/70
	kg	0.7/1.5	1.5/4.3	3.1/11.8	3.1/30.9	6/31.8
Calibration		Compression/Compression				
Material		Alloy Steel/Alloy Steel				

\* Based on largest load cell capacity in stack.

## 2101 DUAL RANGE STANDARD LOAD CELL COMPRESSION-ONLY (U.S. & METRIC)

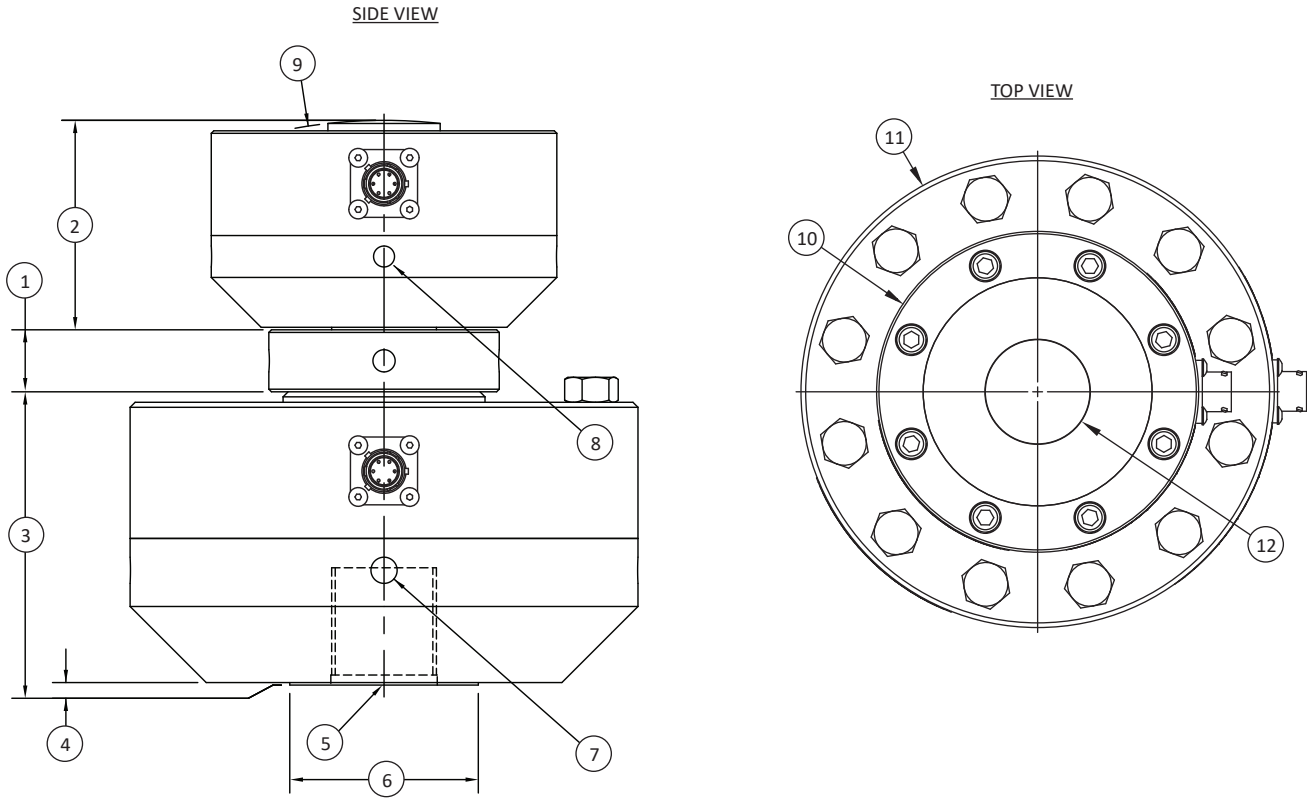

### DIMENSIONS

See Drawing	MODEL									
	2111		2121		2131		2141			
	CAPACITY									
	U.S. (lbf)	Metric (kN)	U.S. (lbf)	Metric (kN)	U.S. (lbf)	Metric (kN)	U.S. (lbf)	Metric (kN)	U.S. (lbf)	Metric (kN)
1K/5K, 2K/10K	5/25, 10/50	5K/25K, 10K/50K	25/100, 50/250	25K/100K	100/450	50K/150K	250/675	100K/270K	450/1200	
in	mm	in	mm	in	mm	in	mm	in	mm	
(1)	0.25	6.35	0.25	6.35	0.25	6.35	0.3125	7.938	0.3125	7.938
(2)	2.51	63.8	2.51	63.8	3.00	76.2	3.00	76.3	4.25	108
(3)	2.51	63.8	3.50	88.9	4.50	114.3	6.50	165.1	8.00	203.2
(4)	0.03	0.8	0.03	0.8	0.03	0.8	0.03	0.8	0.03	0.8
(5)	3/8-18 UNF-3B ↓ 0.87	M16 x 2-4H ↓ 22.1	1 1/4-12 UNF-3B ↓ 1.40	M33 x 2-4H ↓ 35.6	1 1/4-12 UNF-3B ↓ 1.75	M42 x 2-4H ↓ 44.5	2 3/4-8 UNF-3B ↓ 2.75	M72 x 2-4H ↓ 69.8	2 3/4-8 UNF-3B ↓ 2.75	M72 x 2-4H ↓ 69.8
(6)	Ø1.25	Ø31.8	Ø2.25	Ø57.2	Ø3.00	Ø76.2	Ø4.50	Ø114.3	Ø4.50	Ø114.3
(7)	4 X 0.25 ± 0.29	4 X 6.4 ± 7.4	4 X 0.31 ± 0.31	4 X 7.9 ± 7.9	4 X 0.31 ± 0.31	4 X 7.9 ± 7.9	4 X 0.31 ± 0.31	4 X 7.9 ± 7.9	4 X 0.31 ± 0.31	4 X 7.9 ± 7.9
(8)	4 X 0.25 ± 0.29	4 X 6.4 ± 7.4	4 X 0.25 ± 0.29	4 X 6.4 ± 7.4	4 X 0.31 ± 0.31	4 X 7.9 ± 7.9	4 X 0.31 ± 0.31	4 X 7.9 ± 7.9	4 X 0.31 ± 0.31	4 X 7.9 ± 7.9
(9)	SR6.00	SR152.4	SR6.00	SR152.4	SR6.00	SR152.4	SR6.00	SR152.4	SR8.00	SR203.2
(10)	Ø4.13	Ø104.8	Ø4.13	Ø104.8	Ø4.75	Ø120.7	Ø4.75	Ø120.7	Ø7.50	Ø190.5
(11)	Ø4.13	Ø104.8	Ø6.06	Ø153.9	Ø8.00	Ø203.2	Ø11.0	Ø279.0	Ø11.0	Ø279.0
(12)	Ø1.34	Ø34.0	Ø1.34	Ø34.0	Ø1.57	Ø39.9	Ø1.57	Ø39.9	Ø3.13	Ø79.5

Note:  
 • Dimensions are approximate  
 • Contact factory for current drawings

All product descriptions are for general information only. They are not to be understood as a guarantee of quality or durability and do not constitute any liability whatsoever.

2101Dual v2.1 08-06-2020